

**VACON<sup>®</sup> 100 INDUSTRIAL**  
**VACON<sup>®</sup> 100 FLOW**  
AC DRIVES

**VLT<sup>®</sup> ADVANCED HARMONIC FILTER**  
**AHF 005 / AHF 010 FOR VACON<sup>®</sup> 100**  
**DESIGN GUIDE**



# TABLE OF CONTENTS

Date: 13.3.2020







<b>1</b>	<b><i>Introduction</i></b> .....	<b>2</b>
1.1	Intended use.....	2
1.2	Safety.....	2
1.3	Harmonic mitigation.....	3
1.4	Operating principle of the AHF.....	3
<b>2</b>	<b><i>Installation</i></b> .....	<b>3</b>
2.1	Mechanical installation.....	3
2.2	Electrical installation.....	3
2.3	Programming of digital inputs.....	4
<b>3</b>	<b><i>Selection of an AHF filter</i></b> .....	<b>5</b>
3.1	Selection tables .....	5
3.2	Contactors for capacitor disconnection (option).....	9
3.3	Accessories .....	9
<b>4</b>	<b><i>Programming</i></b> .....	<b>9</b>
4.1	Parameter settings .....	9
4.2	Digital inputs .....	10
4.3	Digital outputs .....	10
<b>5</b>	<b><i>Technical data</i></b> .....	<b>10</b>

# 1 Introduction

## 1.1 Intended use

This is an additional guide for the usage of the VLT® Advanced Harmonic Filter (AHF) with VACON® 100 Family drives. The guide gives information on how to install and use an AHF filter with a VACON® 100 Family drive. The Design Guide for VLT® Advanced Harmonic Filter includes all technical and regulatory information which is also usable with VACON® 100 Family drives, and is not replaced by this document.

## 1.2 Safety

	<p><b>WARNING!</b></p> <p>Do not touch the components of the filter when the drive system is connected to mains. The components are live when the drive system is connected to mains. A contact with this voltage is very dangerous.</p>
	<p><b>WARNING!</b></p> <p>Do not touch the input / output terminals of the filter. They can have a dangerous voltage also when the drive system is disconnected from mains.</p>
	<p><b>WARNING!</b></p> <p>Before you do electrical work on the drive system, disconnect the drive from the mains and make sure that the motor has stopped. Lock out and tag out the power source to the drive system. Make sure that no external source generates unintended voltage during work. Note that also the load side of drive system can generate voltage.</p> <p>Wait 5 minutes before you open the the cover of the filter product. Use a measuring device to make sure that there is no voltage. The terminal connections and the components of the filter can be live 5 minutes after the drive system is disconnected from the mains and the motor has stopped.</p>
	<p><b>WARNING!</b></p> <p>Only qualified electricians are allowed to do installation and service work.</p>
	<p><b>WARNING!</b></p> <p>Do not do repair work on a defective product.</p>
	<p><b>HOT SURFACE!</b></p>

	Do not touch the surface of the filter. The surface of the filter product becomes hot during operation.
	<b>CAUTION!</b> Use shielded cables to reduce noise, electromagnetic interference noise and to prevent malfunction in the installation.

### 1.3 Harmonic mitigation

Several mitigation methods can be found for the harmonics caused by AC drives. Most commonly used are passive and active harmonic filters. The VLT® AHF is a passive harmonic filter that consists of capacitors and inductors. The filter series offers two performance levels:

- AHF 005 with 5% THDi
- AHF 010 with 10% THDi

### 1.4 Operating principle of the AHF

The operating principle of the VLT® AHF filter is described in the Design Guide for VLT® Advanced Harmonic Filter.

## 2 Installation

### 2.1 Mechanical installation

Mounting requirements of the VLT® AHF filter can be found in the Design Guide for VLT® Advanced Harmonic Filter.

### 2.2 Electrical installation

General electrical installation instructions can be found in the Design Guide for VLT® Advanced Harmonic Filter.

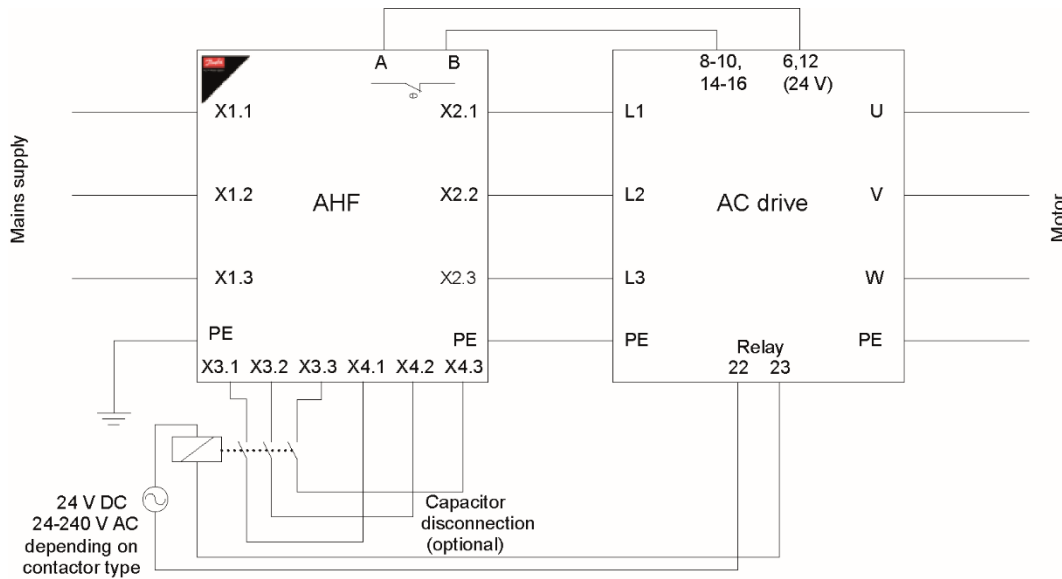

Figure 1. Connection diagram with VACON® 100 Family terminals

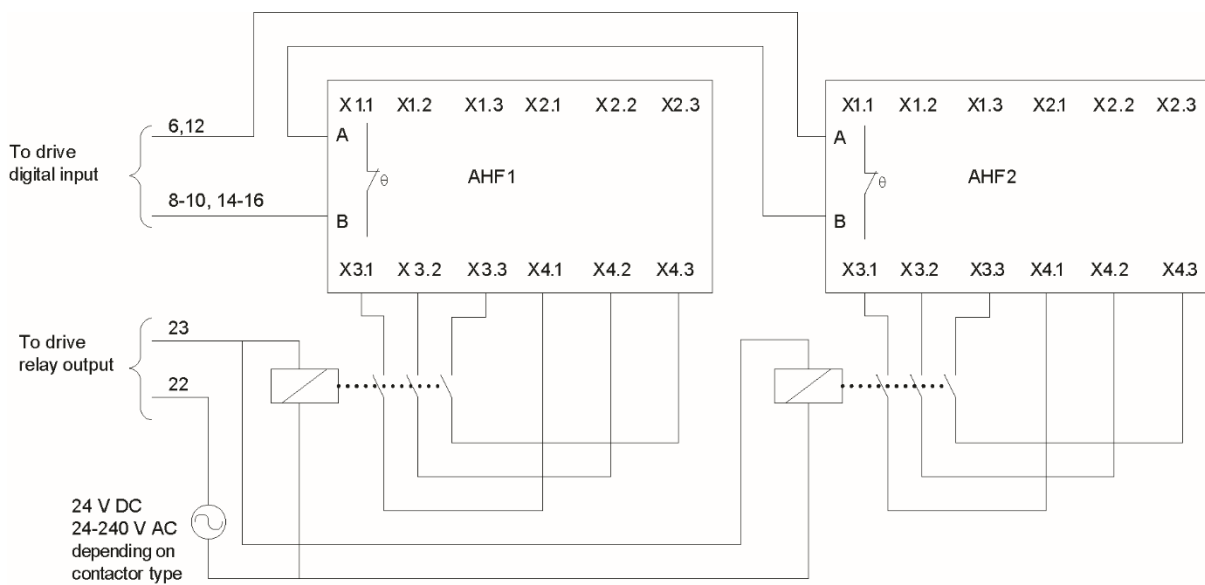

Figure 2. Parallel use of two AHF filters with capacitor disconnection

## 2.3 Programming of digital inputs

Programming example for overtemperature protection in VACON® 100 Family drives is described below.

1. Connect terminal A of the advanced harmonic filter to terminal 6 or 12 (voltage supply digital input, 24 V) of the drive.
2. Connect terminal B to terminal 8-10 or 14-16 of the drive.
3. Program the digital input parameter AHF Over Temperature (P3.5.1.59 in VACON® 100 FLOW or P3.5.1.52 in VACON® 100 INDUSTRIAL) according to the selected digital input terminal.

If an overtemperature is detected, there are four options for parameter AHF fault response (P3.23.4 in VACON® 100 FLOW and P3.22.4 in VACON® 100 INDUSTRIAL):

- 0 = No Action
- 1 = Alarm
- 2 = Fault
- 3 = Fault, Coast

### 3 Selection of an AHF filter

#### 3.1 Selection tables

Table 1. 380 – 415 V, 50Hz

Enclosure size	AC drive values			Filter values							
	Drive type	Power rating	Input current	Current rating	Ordering numbers		Power loss		Acoustic noise	Enclosure size, enclosure protection rating, and fan concept	
			380-500 V		AHF 005	AHF 010	AHF 005	AHF 010		AHF 005	AHF 010
	[kW]	[A]	[A]	IP20		[W]	[W]	[dB]	IP20		
MR4	VACON 0100-3L-0003-5	1.1	3.4	10	130B1229	130B1027	142	86	<70	X1-V3 IP20 if	X1-V3 IP20 if
	VACON 0100-3L-0004-5	1.5	4.6	10	130B1229	130B1027	142	86	<70	X1-V3 IP20 if	X1-V3 IP20 if
	VACON 0100-3L-0005-5	2.2	5.4	10	130B1229	130B1027	142	86	<70	X1-V3 IP20 if	X1-V3 IP20 if
	VACON 0100-3L-0008-5	3	8.1	10	130B1229	130B1027	142	86	<70	X1-V3 IP20 if	X1-V3 IP20 if
	VACON 0100-3L-0009-5	4	9.3	10	130B1229	130B1027	142	86	<70	X1-V3 IP20 if	X1-V3 IP20 if
	VACON 0100-3L-0012-5	5.5	11.3	14	130B1231	130B1058	177	137	<70	X1-V3 IP20 ef	X1-V3 IP20 ef
MR5	VACON 0100-3L-0016-5	7.5	15.4	14	130B1231	130B1058	177	137	<70	X1-V3 IP20 ef	X1-V3 IP20 ef
	VACON 0100-3L-0023-5	11	21.3	22	130B1232	130B1059	286	229	<70	X2-V3 IP20 ef	X2-V3 IP20 if
	VACON 0100-3L-0031-5	15	28.4	29	130B1233	130B1089	357	248	<70	X2-V3 IP20 ef	X2-V3 IP20 if
MR6	VACON 0100-3L-0038-5	18.5	26.7	40	130B1239	130B1111	457	317	<72	X3-V3 IP20 if	X3-V3 IP20 if
	VACON 0100-3L-0046-5	22	43.6	55	130B1240	130B1176	541	387	<72	X3-V3 IP20 if	X3-V3 IP20 if
	VACON 0100-3L-0061-5	30	58.2	66	130B1241	130B1180	717	512	<72	X4-V3 IP20 if	X4-V3 IP20 if
MR7	VACON 0100-3L-0072-5	37	67.5	66	130B1241	130B1180	717	512	<72	X4-V3 IP20 if	X4-V3 IP20 if
	VACON 0100-3L-0087-5	45	85.3	96	130B1248	130B1204	699	554	<75	X5-V3 IP20 ef	X5-V3 IP20 ef
	VACON 0100-3L-0105-5	55	100.66	133	130B1249	130B1207	873	737	<75	X5-V3 IP20 ef	X5-V3 IP20 ef
MR8	VACON 0100-3L-0140-5	75	139.4	171	130B1250	130B1213	1215	895	<75	X6-V3 IP20 ef	X6-V3 IP20 if
	VACON 0100-3L-0170-5	90	166.5	171	130B1250	130B1213	1215	895	<75	X6-V3 IP20 ef	X6-V3 IP20 if
	VACON 0100-3L-0205-5	110	199.6	204	130B1251	130B1214	1253	905	<75	X6-V3 IP20 ef	X6-V3 IP20 if
MR9	VACON 0100-3L-0261-5	132	258	304	130B1259	130B1216	1505	1352	<75	X7-V3 IP20 if	X7-V3 IP20 if
	VACON 0100-3L-0310-5	160	303	304	130B1259	130B1216	1505	1352	<75	X7-V3 IP20 if	X7-V3 IP20 if

Table 2. 380 – 415 V, 60Hz

Enclosure size	AC drive values			Filter values							
	Drive type	Power rating	Input current	Current rating	Ordering numbers		Power loss		Acoustic noise	Enclosure sizes, enclosure protection rating, and fan concept	
			380-500 V		AHF 005	AHF 010	AHF 005	AHF 010		AHF 005	AHF 010
		[kW]	[A]	[A]	IP20		[W]	[W]	[dB]	IP20	
MR4	VACON 0100-3L-0003-5	1.1	3.4	10	130B2857	130B2262	142	86	<70	X1-V3 IP20 if	X1-V3 IP20 if
	VACON 0100-3L-0004-5	1.5	4.6	10	130B2857	130B2262	142	86	<70	X1-V3 IP20 if	X1-V3 IP20 if
	VACON 0100-3L-0005-5	2.2	5.4	10	130B2857	130B2262	142	86	<70	X1-V3 IP20 if	X1-V3 IP20 if
	VACON 0100-3L-0008-5	3	8.1	10	130B2857	130B2262	142	86	<70	X1-V3 IP20 if	X1-V3 IP20 if
	VACON 0100-3L-0009-5	4	9.3	10	130B2857	130B2262	142	86	<70	X1-V3 IP20 if	X1-V3 IP20 if
	VACON 0100-3L-0012-5	5.5	11.3	14	130B2858	130B2265	177	137	<70	X1-V3 IP20 ef	X1-V3 IP20 ef
MR5	VACON 0100-3L-0016-5	7.5	15.4	22	130B2859	130B2268	286	229	<70	X2-V3 IP20 ef	X2-V3 IP20 if
	VACON 0100-3L-0023-5	11	21.3	22	130B2859	130B2268	286	229	<70	X2-V3 IP20 ef	X2-V3 IP20 if
	VACON 0100-3L-0031-5	15	28.4	29	130B2860	130B2294	357	248	<70	X2-V3 IP20 ef	X2-V3 IP20 if
MR6	VACON 0100-3L-0038-5	18.5	26.7	40	130B2862	130B2303	457	317	<72	X3-V3 IP20 if	X3-V3 IP20 if
	VACON 0100-3L-0046-5	22	43.6	55	130B2863	130B2445	541	387	<72	X3-V3 IP20 if	X3-V3 IP20 if
	VACON 0100-3L-0061-5	30	58.2	66	130B2864	130B2459	717	512	<72	X4-V3 IP20 if	X4-V3 IP20 if
MR7	VACON 0100-3L-0072-5	37	67.5	82	130B2865	130B2488	733	447	<72	X4-V3 IP20 ef	X4-V3 IP20 ef
	VACON 0100-3L-0087-5	45	85.3	82	130B2865	130B2488	733	447	<72	X4-V3 IP20 ef	X4-V3 IP20 ef
	VACON 0100-3L-0105-5	55	100.66	133	130B2867	130B2498	873	737	<75	X5-V3 IP20 ef	X5-V3 IP20 ef
MR8	VACON 0100-3L-0140-5	75	139.4	171	130B2868	130B2499	1215	895	<75	X6-V3 IP20 ef	X6-V3 IP20 if
	VACON 0100-3L-0170-5	90	166.5	171	130B2868	130B2499	1215	895	<75	X6-V3 IP20 ef	X6-V3 IP20 if
	VACON 0100-3L-0205-5	110	199.6	204	130B2869	130B2500	1253	905	<75	X6-V3 IP20 ef	X6-V3 IP20 if
MR9	VACON 0100-3L-0261-5	132	258	304	130B2871	130B2819	1505	1352	<75	X8-V3 IP20 if	X7-V3 IP20 if
	VACON 0100-3L-0310-5	160	303	304	130B2871	130B2819	1505	1352	<75	X8-V3 IP20 if	X7-V3 IP20 if

Table 3. 440 – 480 V, 60Hz

Enclosure size	AC drive values			Filter values							
	Drive type	Power rating	Input current	Current rating	Ordering numbers		Power loss		Acoustic noise	Enclosure sizes, enclosure protection rating, and fan concept	
			380-500 V		AHF 005	AHF 010	AHF 005	AHF 010		AHF 005	AHF 010
		[kW]	[A]	[A]	IP20		[W]	[W]	[dB]	IP20	
MR4	VACON 0100-3L-0003-5	1.1	3.4	10	130B1752	130B1482	163	99	<70	X1-V3 IP20 if	X1-V3 IP20 if
	VACON 0100-3L-0004-5	1.5	4.6	10	130B1752	130B1482	163	99	<70	X1-V3 IP20 if	X1-V3 IP20 if
	VACON 0100-3L-0005-5	2.2	5.4	10	130B1752	130B1482	163	99	<70	X1-V3 IP20 if	X1-V3 IP20 if
	VACON 0100-3L-0008-5	3	8.1	10	130B1752	130B1482	163	99	<70	X1-V3 IP20 if	X1-V3 IP20 if
	VACON 0100-3L-0009-5	4	9.3	10	130B1752	130B1482	163	99	<70	X1-V3 IP20 if	X1-V3 IP20 if
	VACON 0100-3L-0012-5	5.5	11.3	14	130B1753	130B1483	206	160	<70	X1-V3 IP20 ef	X1-V3 IP20 ef



MR5	VACON 0100-3L-0016-5	7.5	15.4	25	130B1755	130B1485	354	245	<70	X2-V3 IP20 ef	X2-V3 IP20 if
	VACON 0100-3L-0023-5	11	21.3	25	130B1755	130B1485	354	245	<70	X2-V3 IP20 ef	X2-V3 IP20 if
	VACON 0100-3L-0031-5	15	28.4	31	130B1756	130B1486	448	301	<70	X3-V3 IP20 if	X3-V3 IP20 if
MR6	VACON 0100-3L-0038-5	18.5	26.7	36	130B1757	130B1487	474	329	<72	X3-V3 IP20 if	X3-V3 IP20 if
	VACON 0100-3L-0046-5	22	43.6	48	130B1758	130B1488	543	389	<72	X3-V3 IP20 if	X3-V3 IP20 if
	VACON 0100-3L-0061-5	30	58.2	60	130B1759	130B1491	751	537	<72	X4-V3 IP20 if	X4-V3 IP20 if
MR7	VACON 0100-3L-0072-5	37	67.5	73	130B1760	130B1492	751	458	<72	X4-V3 IP20 ef	X4-V3 IP20 ef
	VACON 0100-3L-0087-5	45	85.3	95	130B1761	130B1493	801	635	<75	X5-V3 IP20 ef	X5-V3 IP20 ef
	VACON 0100-3L-0105-5	55	100.66	118	130B1762	130B1494	891	753	<75	X5-V3 IP20 ef	X5-V3 IP20 ef
MR8	VACON 0100-3L-0140-5	75	139.4	154	130B1763	130B1495	1260	928	<75	X6-V3 IP20 ef	X6-V3 IP20 if
	VACON 0100-3L-0170-5	90	166.5	183	130B1764	130B1496	1293	935	<75	X6-V3 IP20 ef	X6-V3 IP20 if
	VACON 0100-3L-0205-5	110	199.6	231	130B1765	130B1497	1450	1267	<75	X7-V3 IP20 if	X7-V3 IP20 if
MR9	VACON 0100-3L-0261-5	132	258	291	130B1766	130B1498	1664	1496	<75	X8-V3 IP20 if	X7-V3 IP20 if
	VACON 0100-3L-0310-5	160	303	355	130B1768	130B1499	2098	1758	<75	X8-V3 IP20 ef	X7-V3 IP20 ef

Table 4. 525 – 600 V, 60Hz

Enclosure size	AC drive values				Filter values						
	Drive type	Power rating	Input current	Current rating	Ordering numbers		Power loss		Acoustic noise	Enclosure sizes, enclosure protection rating, and fan concept	
			600 V		AHF 005	AHF 010	AHF 005	AHF 010		AHF 005	AHF 010
		[Hp]	[A]	[A]	IP20		[W]	[W]	[dB]	IP20	
MR5	VACON 0100-3L-0004-6	3	4.6	15	130B5246	130B5212	301	245	<70	X3-V3 IP20 if	X3-V3 IP20 if
	VACON 0100-3L-0006-6	5	6.8	15	130B5246	130B5212	301	245	<70	X3-V3 IP20 if	X3-V3 IP20 if
	VACON 0100-3L-0009-6	7.5	9	15	130B5246	130B5212	301	245	<70	X3-V3 IP20 if	X3-V3 IP20 if
	VACON 0100-3L-0011-6	10	10.5	15	130B5246	130B5212	301	245	<70	X3-V3 IP20 if	X3-V3 IP20 if
MR6	VACON 0100-3L-0018-6	15	19.9	20	130B5247	130B5213	388	276	<70	X3-V3 IP20 if	X3-V3 IP20 if
	VACON 0100-3L-0022-6	20	23.3	24	130B5248	130B5214	428	315	<70	X3-V3 IP20 ef	X3-V3 IP20 ef
	VACON 0100-3L-0027-6	25	27.2	29	130B5249	130B5215	450	331	<70	X4-V3 IP20 ef	X4-V3 IP20 ef
	VACON 0100-3L-0034-6	30	32.8	36	130B5250	130B5216	611	445	<70	X4-V3 IP20 ef	X4-V3 IP20 ef
MR7	VACON 0100-3L-0041-6	40	45.3	50	130B5251	130B5217	642	454	<70	X5-V3 IP20 ef	X5-V3 IP20 ef
	VACON 0100-3L-0052-6	50	53.8	58	130B5252	130B5218	691	531	<70	X5-V3 IP20 ef	X5-V3 IP20 ef
	VACON 0100-3L-0062-6	60	62.2	77	130B5253	130B5219	870	669	<72	X6-V3 IP20 ef	X6-V3 IP20 ef
MR8	VACON 0100-3L-0080-6	75	90	87	130B5254	130B5220	1001	770	<72	X6-V3 IP20 ef	X6-V3 IP20 ef
	VACON 0100-3L-0100-6	100	106	109	130B5255	130B5221	1038	798	<72	X6-V3 IP20 ef	X6-V3 IP20 ef
	VACON 0100-3L-0125-6	125	127	128	130B5256	130B5222	1091	909	<75	X6-V3 IP20 ef	X6-V3 IP20 ef
MR9	VACON 0100-3L-0144-6	150	156	155	130B5257	130B5223	1397	1164	<75	X7-V3 IP20 ef	X7-V3 IP20 ef
	VACON 0100-3L-0208-6	200	212	240	130B5259	130B5225	1831	1591	<75	X8-V3 IP20 ef	X7-V3 IP20 ef

Table 5. 525 – 690 V, 50Hz

Enclosure size	AC drive values			Filter values								
	Drive type	Power rating	Input current	Current rating		Ordering numbers		Power loss		Acoustic noise	Enclosure sizes, enclosure protection rating, and fan concept	
			525-690 V	AHF 005	AHF 010	AHF 005	AHF 010	AHF 005	AHF 010		AHF 005	AHF 010
	[kW]	[A]	[A]	[A]	IP20		[W]	[W]	[dB]	IP20		
MR6	VACON 0100-3L-0007-7	5.5	9.1	15	15	130B5088	130B5280	347	282	<70	X3-V3 IP20 if	X3-V3 IP20 if
	VACON 0100-3L-0010-7	7.5	11.7	15	15	130B5088	130B5280	347	282	<70	X3-V3 IP20 if	X3-V3 IP20 if
	VACON 0100-3L-0013-7	11	15.5	15	15	130B5088	130B5280	347	282	<70	X3-V3 IP20 if	X3-V3 IP20 if
	VACON 0100-3L-0018-7	15	19.9	20	20	130B5089	130B5281	446	318	<70	X3-V3 IP20 if	X3-V3 IP20 if
	VACON 0100-3L-0022-7	18.5	23.3	24	24	130B5090	130B5282	493	362	<70	X3-V3 IP20 ef	X3-V3 IP20 ef
	VACON 0100-3L-0027-7	22	27.2	29	29	130B5092	130B5283	518	381	<70	X4-V3 IP20 ef	X4-V3 IP20 ef
	VACON 0100-3L-0034-7	30	32.8	36	36	130B5125	130B5284	703	512	<70	X4-V3 IP20 ef	X4-V3 IP20 ef
MR7	VACON 0100-3L-0041-7	37	45.3	50	50	130B5144	130B5285	718	522	<70	X5-V3 IP20 ef	X5-V3 IP20 ef
	VACON 0100-3L-0052-7	45	53.8	58	58	130B5168	130B5286	795	611	<72	X5-V3 IP20 ef	X5-V3 IP20 ef
	VACON 0100-3L-0062-7	55	62.2	77	77	130B5169	130B5287	1001	770	<72	X6-V3 IP20 ef	X6-V3 IP20 ef
MR8	VACON 0100-3L-0080-7	75	90	87	87	130B5170	130B5288	1152	886	<72	X6-V3 IP20 ef	X6-V3 IP20 ef
	VACON 0100-3L-0100-7	90	106	109	109	130B5172	130B5289	1194	918	<72	X6-V3 IP20 ef	X6-V3 IP20 ef
	VACON 0100-3L-0125-7	110	127	128	128	130B5195	130B5290	1255	1046	<72	X6-V3 IP20 ef	X6-V3 IP20 ef
MR9	VACON 0100-3L-0144-7	132	156	155	155	130B5196	130B5291	1607	1339	<72	X7-V3 IP20 ef	X7-V3 IP20 ef
	VACON 0100-3L-0170-7	160	179	197	197	130B5197	130B5292	1734	1515	<72	X7-V3 IP20 ef	X7-V3 IP20 ef
	VACON 0100-3L-0208-7	200	212	240	240	130B5198	130B5293	2106	1830	<75	X8-V3 IP20 ef	X7-V3 IP20 ef

## 3.2 Contactors for capacitor disconnection (option)

The power factor of the VLT® AHF filter decreases with a decreasing load. When there is no load, the power factor is 0, and the capacitors produce a leading current of approximately 25% of the rated filter current. In applications where reactive current is not acceptable, the disconnection of capacitors is required.

The AHF filter terminals X3.1, X3.2, X3.3 and X4.1, X4.2, X4.3 are shorted as default. If disconnection of capacitors is required, the shorting is removed and a 3-phase contactor is placed between terminals X3 and X4.

**NOTE!** During the download of a VACON® 100 software, it is recommended to short the AHF filter terminals X3.1, X3.2, X3.3 and X4.1, X4.2, X4.3 to avoid unnecessary capacitor disconnections.

**NOTE!** It is recommended to use contactors designed for capacitive switching with VACON® 100 Family drives. These contactors include damping resistors that reduce the inrush peak current and peak voltage level in the DC bus of the drive.

In some cases, the DC bus peak voltage can reach the hardware trip level with standard AC-3 type contactors and cause the drive to shut down. This can happen during disconnection or connection of the filter capacitors at low load. It is possible to control the disconnection of capacitors with parameter settings (see chapter Programming).

## 3.3 Accessories

Available upgrade kits are listed in the Design Guide for VLT® Advanced Harmonic Filter. Available kits for the VACON® 100 Family drives:

- IP21 / NEMA 1 Upgrade Kit
- Backplate for IP20 (to correct the air flow in a rail assembly).

# 4 Programming

## 4.1 Parameter settings

The parameters related to the VLT® AHF filter (VACON® 100 FLOW / VACON® 100 INDUSTRIAL):

P3.23.1 / P3.22.1	Cap Disconnect Limit
P3.23.2 / P3.22.2	Cap Disconnect Hysteresis
P3.23.3 / P3.22.3	AHF Over Temperature
P3.23.4 / P3.22.4	AHF Response

The settings of these parameters are described in the VACON® 100 FLOW Application Manual and the VACON® 100 INDUSTRIAL Application Manual.

**NOTE!** The default setting for parameter P3.23.1 / P3.22.1 is 0% with the capacitor disconnection not in use. If the capacitor disconnection is activated, the value of parameter P3.23.1 / P3.22.1 must be set between 10-30%.

## 4.2 Digital inputs

Program the digital input parameter AHF Over Temperature (P3.5.1.59 in VACON® 100 FLOW and P3.5.1.52 in VACON® 100 INDUSTRIAL) according to the selected input terminal.

VACON® 100 FLOW :

P3.5.1.59 AHF Over Temperature (ID 15513): default value = DigIN Slot0.1

VACON® 100 INDUSTRIAL:

P3.5.1.52 AHF Over Temperature (ID 15513): default value = DigIN Slot0.1

## 4.3 Digital outputs

Program the digital output parameter R01 Function (P3.5.3.2.1) according the capacitor disconnection selection.

VACON® 100 FLOW:

P3.5.3.2.1 R01 Function (ID 11001): value 72 = AHF Cap Disconnect, value 73 = AHF Cap Disconnect Inverted

VACON® 100 INDUSTRIAL:

P3.5.3.2.1 R01 Function (ID 11001): value 60 = AHF Cap Disconnect, value 61 = AHF Cap Disconnect Inverted

## 5 Technical data

The technical data including mechanical dimensions can be found in the Design Guide for VLT® Advanced Harmonic Filter.



# VACON®

[www.danfoss.com](http://www.danfoss.com)

Vacon Ltd  
Member of the Danfoss Group  
Runsorintie 7  
65380 Vaasa  
Finland

130R0809

