

# In-bottom/Out-back Cooling Kit for FA09-FA10 iC7 Series Frequency Converters

## 1 Overview

### 1.1 Description

The in-bottom/out-back cooling kit fits FA09 and FA10 frequency converters mounted in Rittal TS8 and VX25 cabinets. When the kit is installed, air flows into the bottom duct and out through the back duct of the frequency converter. See [Illustration 1](#).

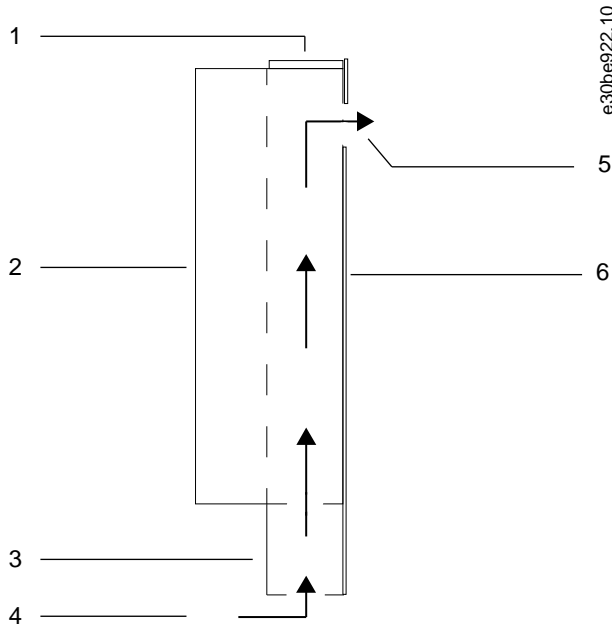

Illustration 1: Direction of Airflow with Kit Installed

1	Top cover	4	Back channel airflow (intake)
2	Frequency converter	5	Back channel airflow (exhaust)
3	Bottom duct assembly	6	Mounting plate

### 1.2 Kit Numbers

Use these instructions with the following kits.

Table 1: Numbers for In-bottom/Out-back Cooling Kits

Number	Kit description
176F4040	In-bottom/Out-back cooling kit for FA09 frequency converters
176F4041	In-bottom/Out-back cooling kit for FA10 frequency converters

### 1.3 Items Supplied

The kit contains the following parts:

Table 2: Contents of In-bottom/Out-back Cooling Kit

Item	Quantity
Telescopic bottom duct assembly	1
Rubber EPDM ribbed seal	1
Cutout gasket	1
Drive slot gasket	1
Seal plate gasket	2
Seal plate	2
Duct support plate	1
Duct support plate gasket	1
Top cover	1
Top cover gasket	1
Back vent	1
Back vent gasket	2
Mounting plate gasket	2
Backplate gasket	2
Clip-on nut	12
M10x30 screw	4
M5x16 countersunk screw	7
M5x18 screw	6-8
M6x12 screw	6-8
M5x10 taptite screw	5-10
M5 hex nut	6

## 2 Installation

### 2.1 Safety Information

#### NOTICE

##### QUALIFIED PERSONNEL

Only qualified personnel are allowed to install the parts described in these installation instructions.

- Disassembly and reassembly of the frequency converter must be done in accordance with the corresponding service guide.
- Use the standard fastener torque values from the service guide, unless the torque value is specified in these instructions.

#### ⚠ WARNING ⚠

##### ELECTRICAL SHOCK HAZARD

The frequency converter contains dangerous voltages when connected to mains voltage. Improper installation, and installing or servicing with power connected, can cause death, serious injury, or equipment failure.

- Only use qualified electricians for the installation.
- Disconnect the frequency converter from all power sources before installation or service.
- Treat the frequency converter as live whenever the mains voltage is connected.
- Follow the guidelines in these instructions and local electrical safety regulations.

#### ⚠ WARNING ⚠

##### DISCHARGE TIME (20 MINUTES)

The frequency converter contains DC-link capacitors, which can remain charged even when the frequency converter is not powered. High voltage can be present even when the warning indicator lights are off.

Failure to wait 20 minutes after power has been removed before performing service or repair work can result in death or serious injury.

- Stop the motor.
- Disconnect AC mains, permanent magnet type motors, and remote DC-link supplies, including battery backups, UPS, and DC-link connections to other frequency converters.
- Wait 20 minutes for the capacitors to discharge fully before performing any service or repair work.
- To verify full discharge, measure the voltage level.

#### NOTICE

##### ELECTROSTATIC DISCHARGE

Electrostatic discharge can damage components.

- Ensure discharge before touching internal frequency converter components, for example by touching a grounded, conductive surface or by wearing a grounded armband.

### 2.2 Installation Overview

#### NOTICE

##### APPLYING GASKETS

This kit contains self-adhesive gaskets to ensure a proper seal between metal parts.

- Before affixing a gasket, check that the part matches the gasket and that no holes are covered.

e30bj238.10

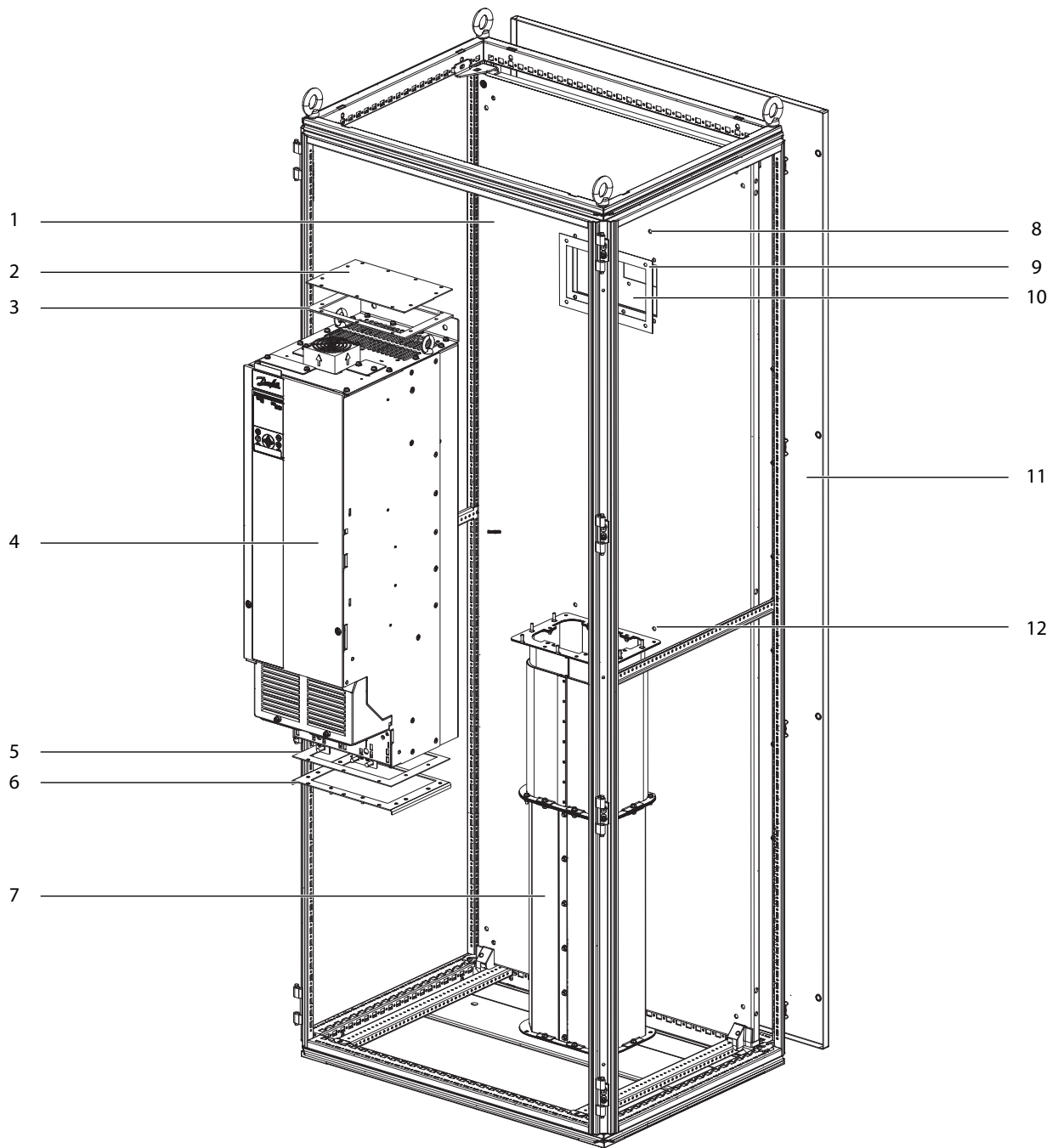

Illustration 2: Overview of In-bottom/Out-back Cooling Kit

1	Mounting plate	7	Telescopic bottom duct
2	Top cover	8	Upper mounting hole
3	Top cover gasket	9	Mounting plate gasket
4	Frequency converter	10	Back vent
5	Duct support plate gasket	11	Backplate
6	Duct support plate	12	Lower mounting hole

### 2.3 Preparing the Mounting Plate

To create mounting holes and vent holes in the mounting plate, use the following steps. Use the dimensions in [Illustration 3](#) for FA09 frequency converters, and [Illustration 4](#) for FA10 frequency converters.

**Procedure**

1. Drill 4 mounting holes in the mounting plate using the dimensions in the template.

The holes must match the holes in the frequency converter.

2. Insert 4 M10 pem nuts (not supplied) in the mounting holes.
3. Cut out the vent opening in the mounting plate using the dimensions in the template.

The openings must match the upper duct opening in the frequency converter.

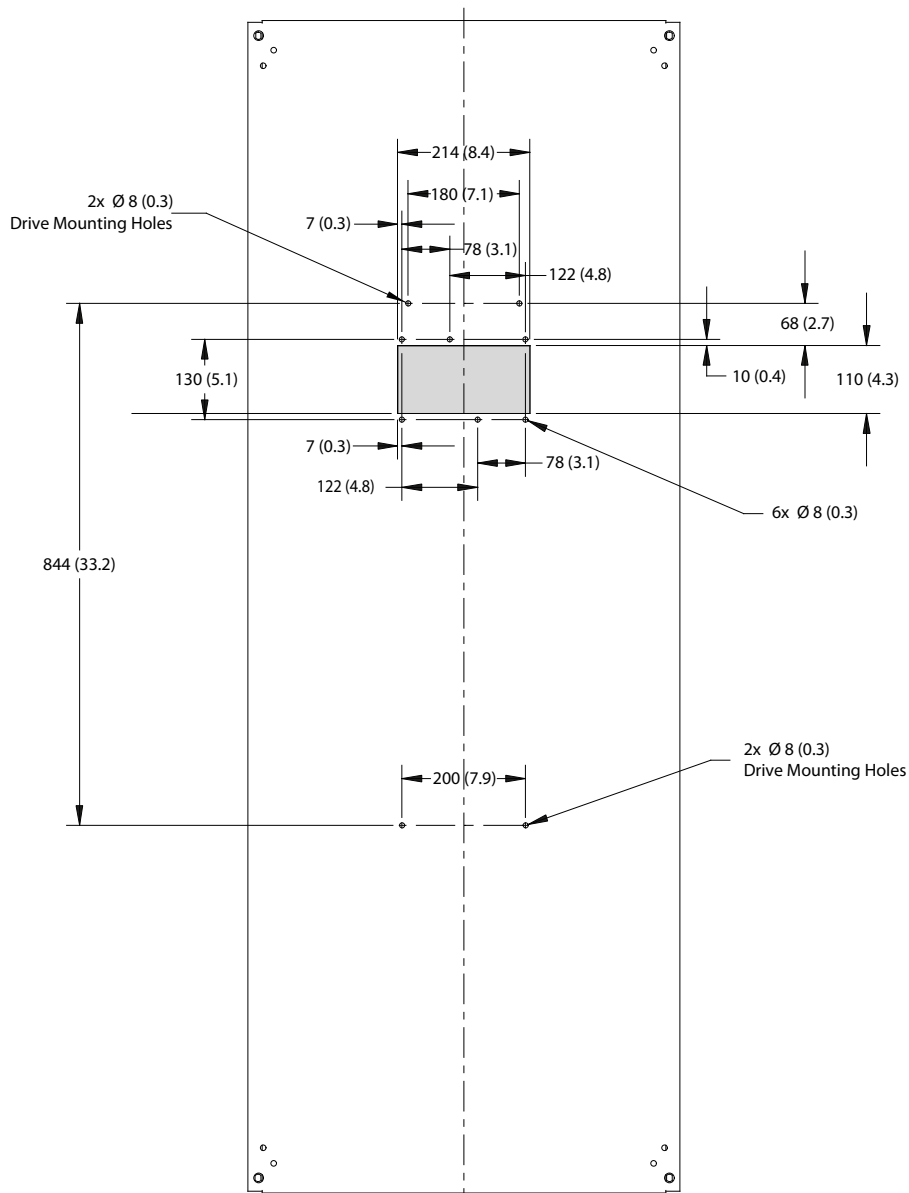

e30bj223.10

**Illustration 3: FA09 Mounting Plate Template for In-bottom/Out-back Cooling**

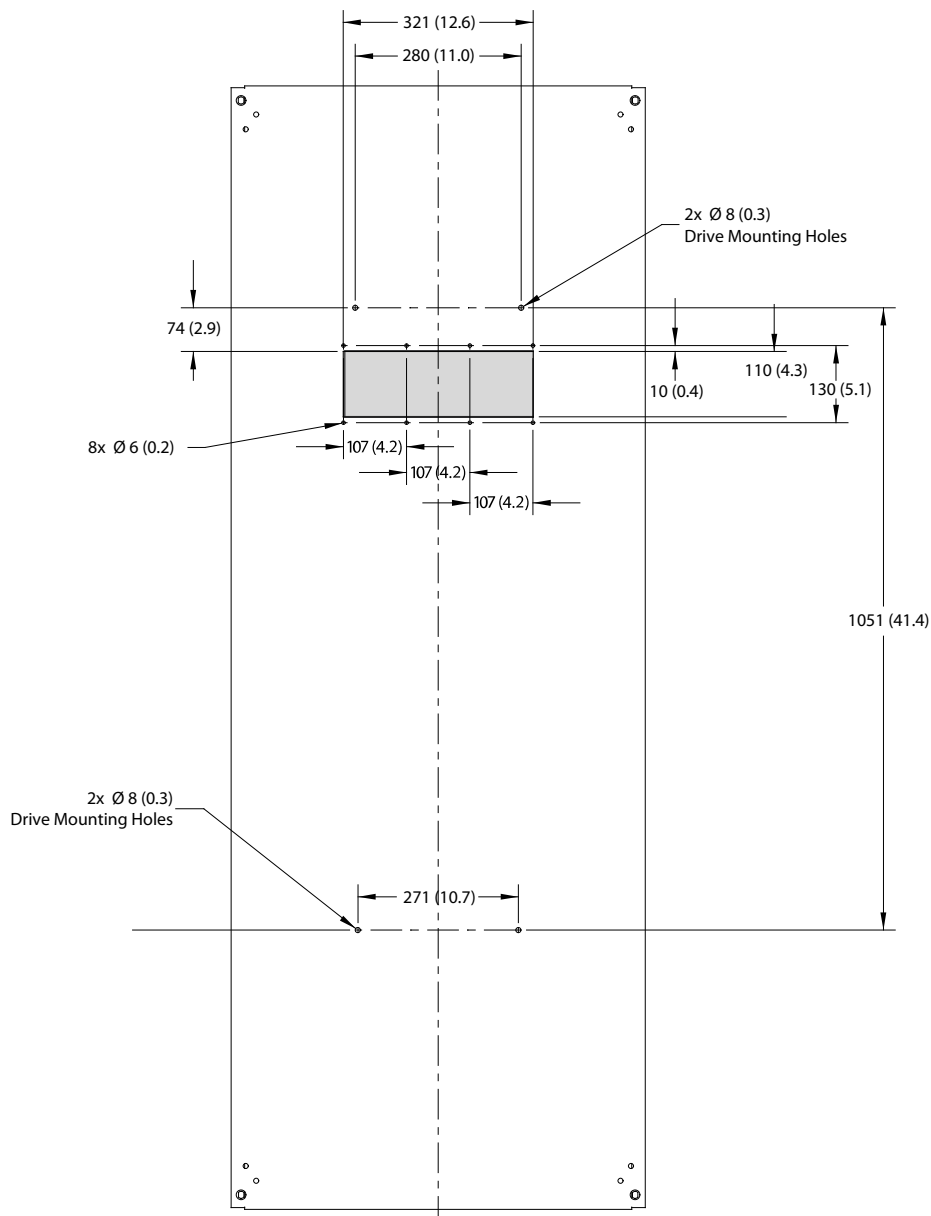

Illustration 4: FA10 Mounting Plate Template for In-bottom/Out-back Cooling

## 2.4 Preparing the Backplate

To create a vent opening in the cabinet backplate to match the opening in the mounting plate, use the following steps. Use the dimensions in [Illustration 5](#) for FA09 frequency converters, and [Illustration 6](#) for FA10 frequency converters.

### Procedure

1. Cut out the vent opening in the cabinet backplate using the dimensions in the template.

The vent opening must match the mounting plate opening.

2. Drill screw holes (6 mm) around the vent opening using the dimensions in the template.

The FA09 requires 6 holes around the vent opening, and the FA10 requires 8 holes around the opening. The holes must align with the holes in the outer flanges of the back vent.

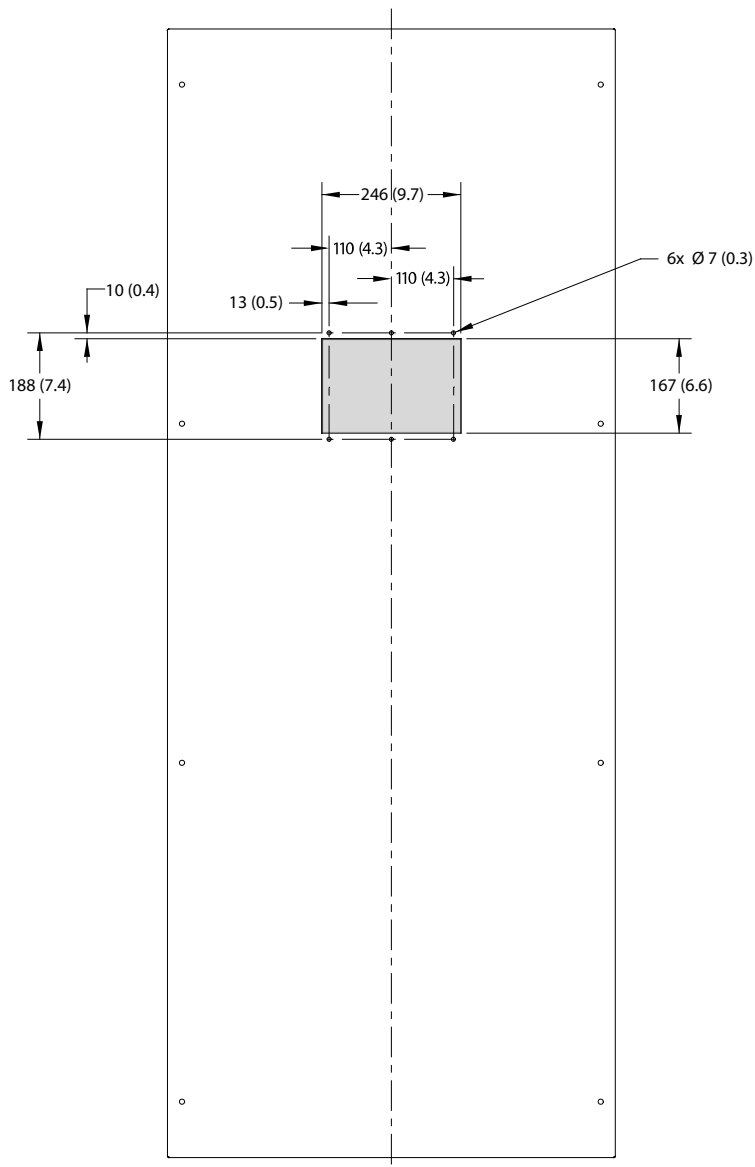

e30bj234.10

Illustration 5: FA09 Cabinet Backplate Template for In-bottom/Out-back Cooling

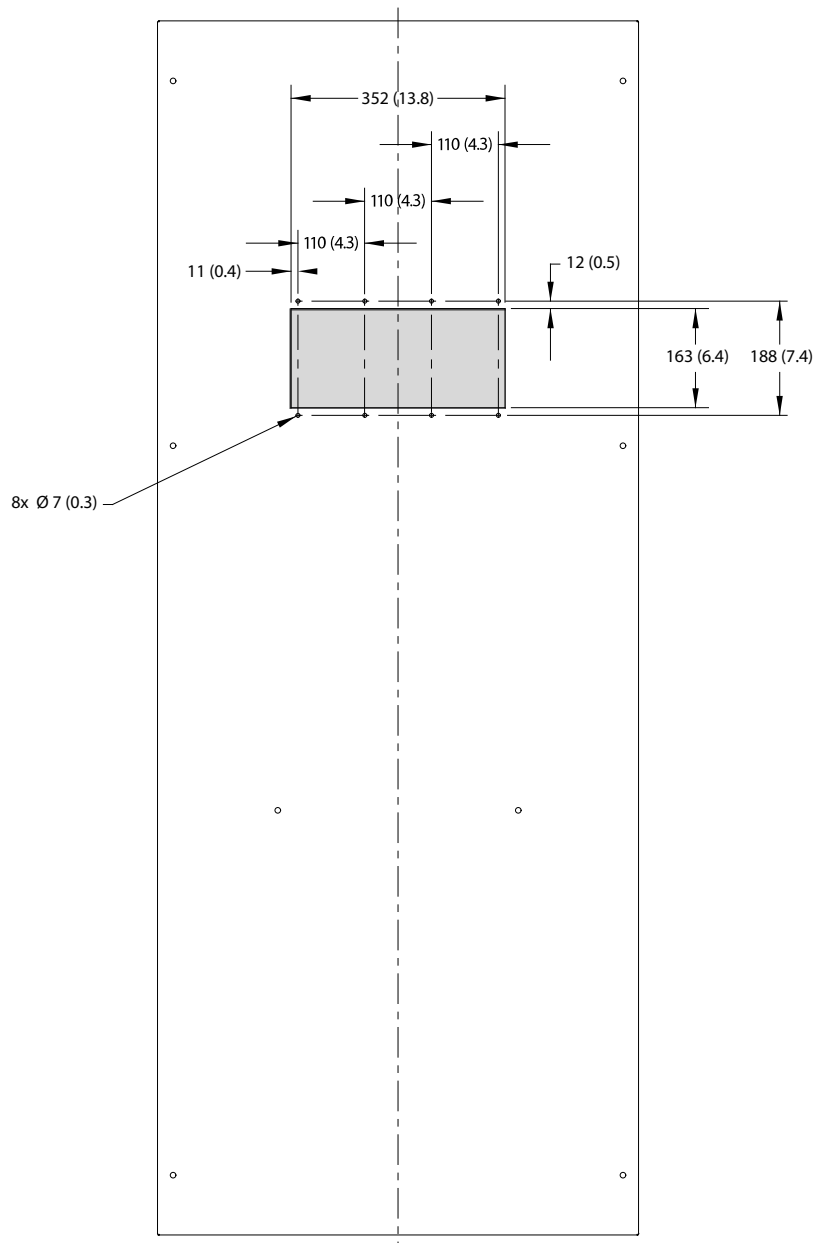

e30bj235.10

Illustration 6: FA10 Cabinet Backplate Template for In-bottom/Out-back Cooling

## 2.5 Installing the Top Cover

To install the top cover of the cooling kit, use the following steps. See [Illustration 7](#).

### Procedure

1. Remove the paper backing from the top cover gasket to expose the adhesive.
2. Adhere the top cover gasket to the underside of the top cover.
3. Remove 8 M5x14 screws (T25) surrounding the sides and back of the vent in the top of the frequency converter. Retain the screws.
4. Remove 3 M5x12 screws (T25) at the front of the vent in the top surface of the frequency converter.
5. Slide the edge of the top cover under the 3 loosened screws, positioning the cover over the vent in the top of the frequency converter.
6. Secure the top cover to the frequency converter with the M5x14 screws (T25) removed previously in step 3.

Torque all screws to 2.3 Nm (20 in-lb).



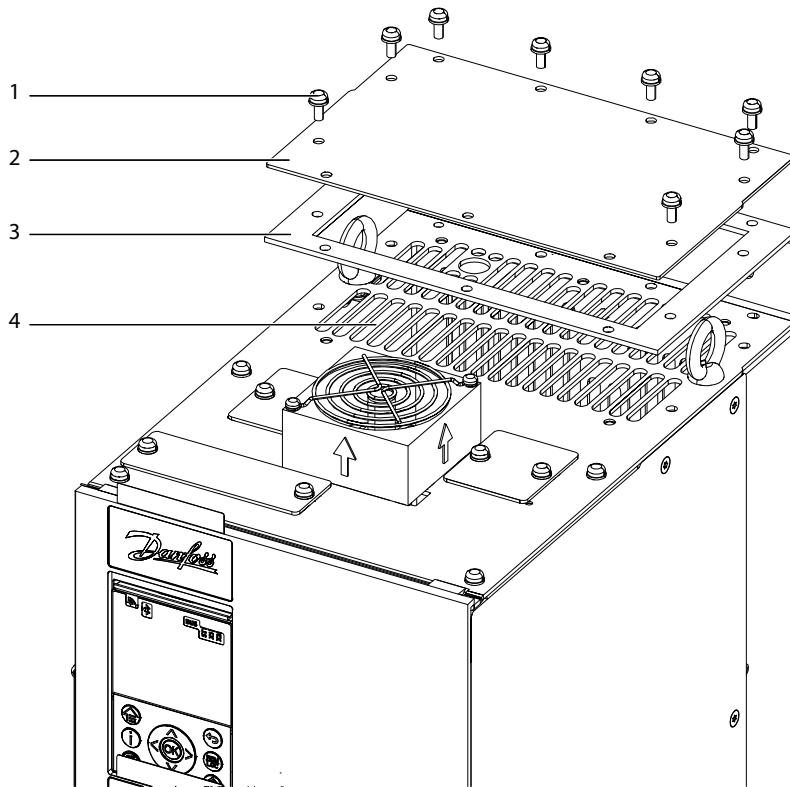

Illustration 7: Installation of the Top Cover

1	M5x14 screws	3	Top cover gasket
2	Top cover	4	Top vent

## 2.6 Creating a Vent Opening in the Base Plate

To create a vent opening in the base plate for the bottom duct, use the following steps. Use the dimensions in [Illustration 8](#) for FA09 frequency converters, and [Illustration 9](#) for FA10 frequency converters.

### Procedure

1. Cut out the vent opening in the cabinet base plate using the dimensions in the template.
2. Drill 6 screw holes (4 mm) around the vent opening using the dimensions in the template.

The holes must match the holes in the lower flange of the bottom duct.

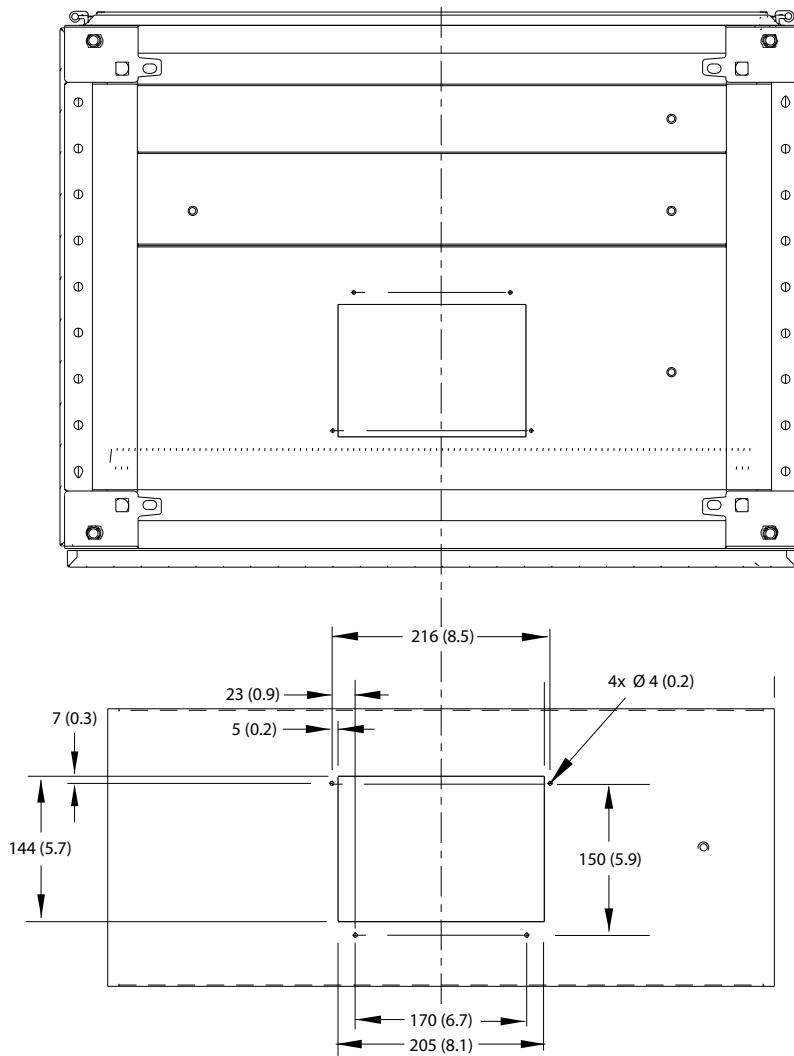

e30bg400.10

Illustration 8: FA09 Base Plate Template

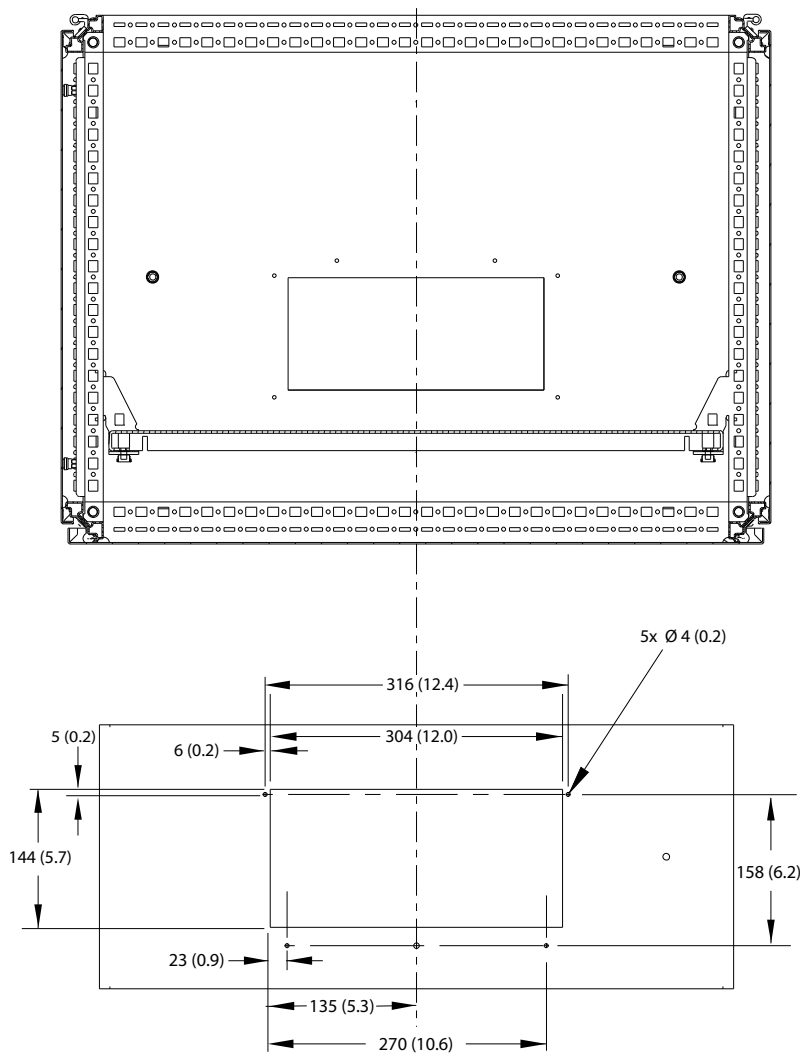

Illustration 9: FA10 Base Plate Template

## 2.7 Mounting the Frequency Converter

To install the mounting plate and frequency converter in the Rittal cabinet, use the following steps. Refer to [Illustration 10](#).

### Procedure

1. Attach the mounting plate to the cabinet rails, making sure that the pem nuts face the back of the cabinet.
2. Remove the backing paper from the self adhesive on the cutout gasket.
3. Affix the gasket over the duct opening in the mounting plate.
4. Remove the backing paper from the self adhesive on the strip gasket.
5. Affix the gasket over the lower 2 pem nuts in the mounting plate.
6. Remove the backing paper from the 2 seal plate gaskets, and affix the gaskets to the seal plates, 1 per plate.
7. Fasten 2 M10x30 screws through the seal plates, 1 per plate, and into the pem nuts at the lower end of the mounting plate.

Make sure that the screws are secure. The base of the frequency converter rests on the screws.

8. Slightly lean the top of the frequency converter forward and set the cutouts in the base onto the 2 screws.
9. Slowly push the top of the frequency converter back against the mounting plate until the top 2 pem nuts line up with the holes in the frequency converter.
10. Secure the top of the frequency converter using 2 M10x30 screws.

Torque all M10x30 screws to 19 Nm (170 in-lb).

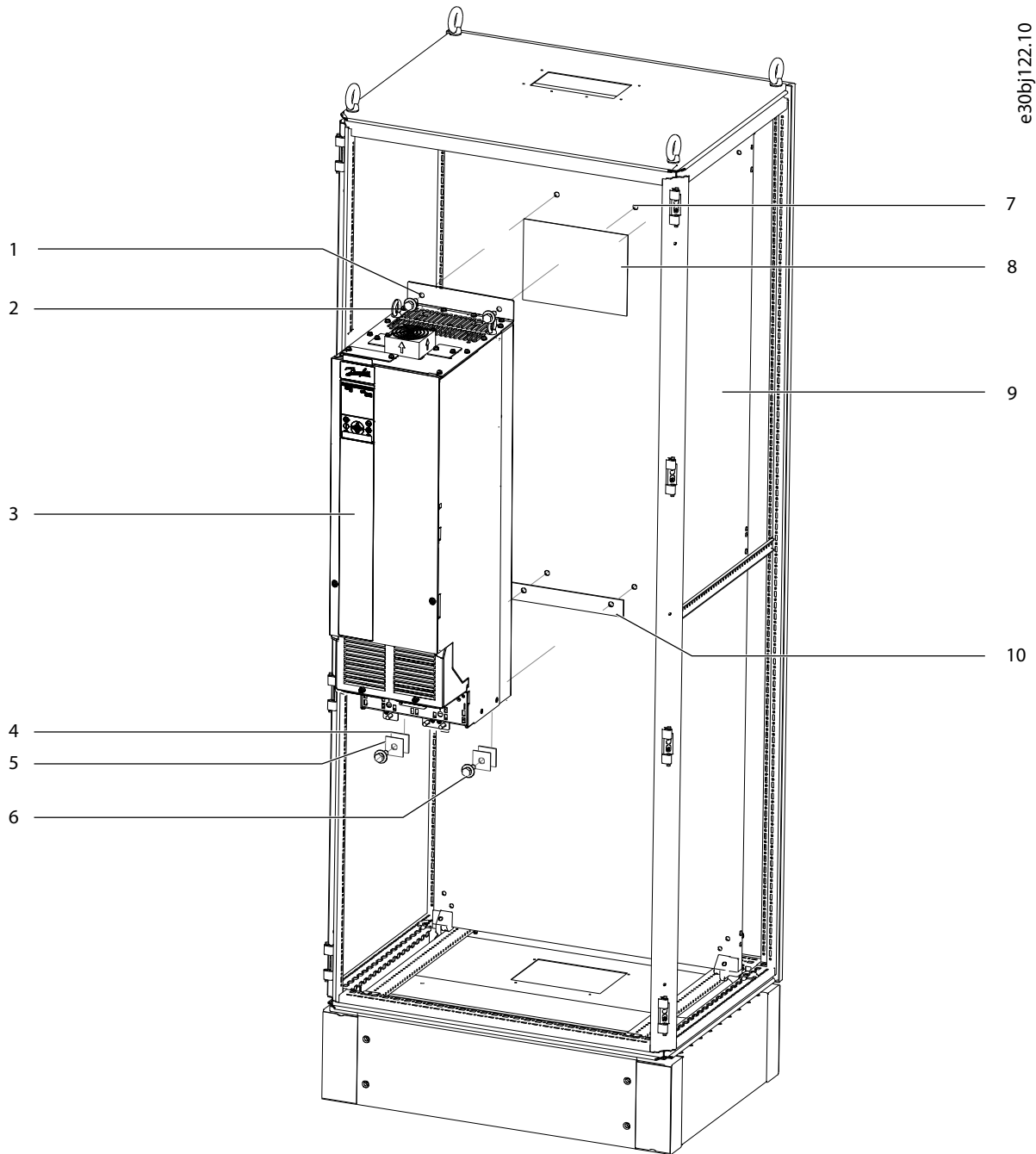

Illustration 10: Installation of the Frequency Converter in the Cabinet

1	Mounting holes	6	M10x30 screw
2	M10x30 screw	7	Pem nuts
3	Frequency converter	8	Cutout gasket
4	Seal plate gasket	9	Mounting plate
5	Seal plate	10	Strip gasket

## 2.8 Installing the Duct Support Plate

The duct support plate attaches the bottom duct to the lower end of the frequency converter. To install the duct support plate, use the following steps. Refer to [Illustration 11](#).

### Procedure

1. Remove the paper backing from the duct support plate gasket.
2. Adhere the gasket to the upper surface of the duct support plate.
3. Position the duct support plate at the lower end of the frequency converter.
4. Secure the duct support plate to the frequency converter using 7 M5x16 countersunk screws (T25).

Torque fasteners to 2.3 Nm (20 in-lb).

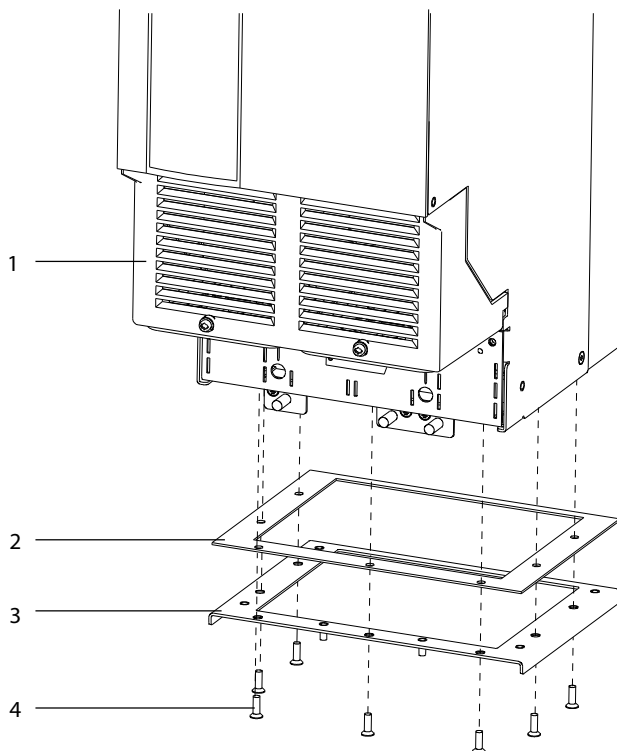

e30bj141.10

Illustration 11: Installation of the Duct Support Plate

1	Frequency converter	3	Duct support plate
2	Duct support plate gasket	4	M5x16 countersunk screw

## 2.9 Assembling the Bottom Duct

The bottom duct is a telescopic duct that collapses to simplify installation. To assemble the duct prior to installation, use the following steps. Refer to [Illustration 12](#).

### Procedure

1. Cut the strip of ribbed EPDM rubber seal into 2 pieces. Use the following measurements:
  - a. For FA09 frequency converters, cut 2 strips of 682 mm (26.9 in).
  - b. For FA10 frequency converters, cut 2 strips of 877 mm (34.5 in).
2. Peel the paper off the self-adhesive seals.
3. Place 1 rubber seal strip on the outside bottom edge of the inner sleeve of the duct, and 1 rubber seal strip on the upper inside edge of the outer sleeve of the duct.

- With the rubber seals in place, carefully slide the inner sleeve of the duct into the outer sleeve

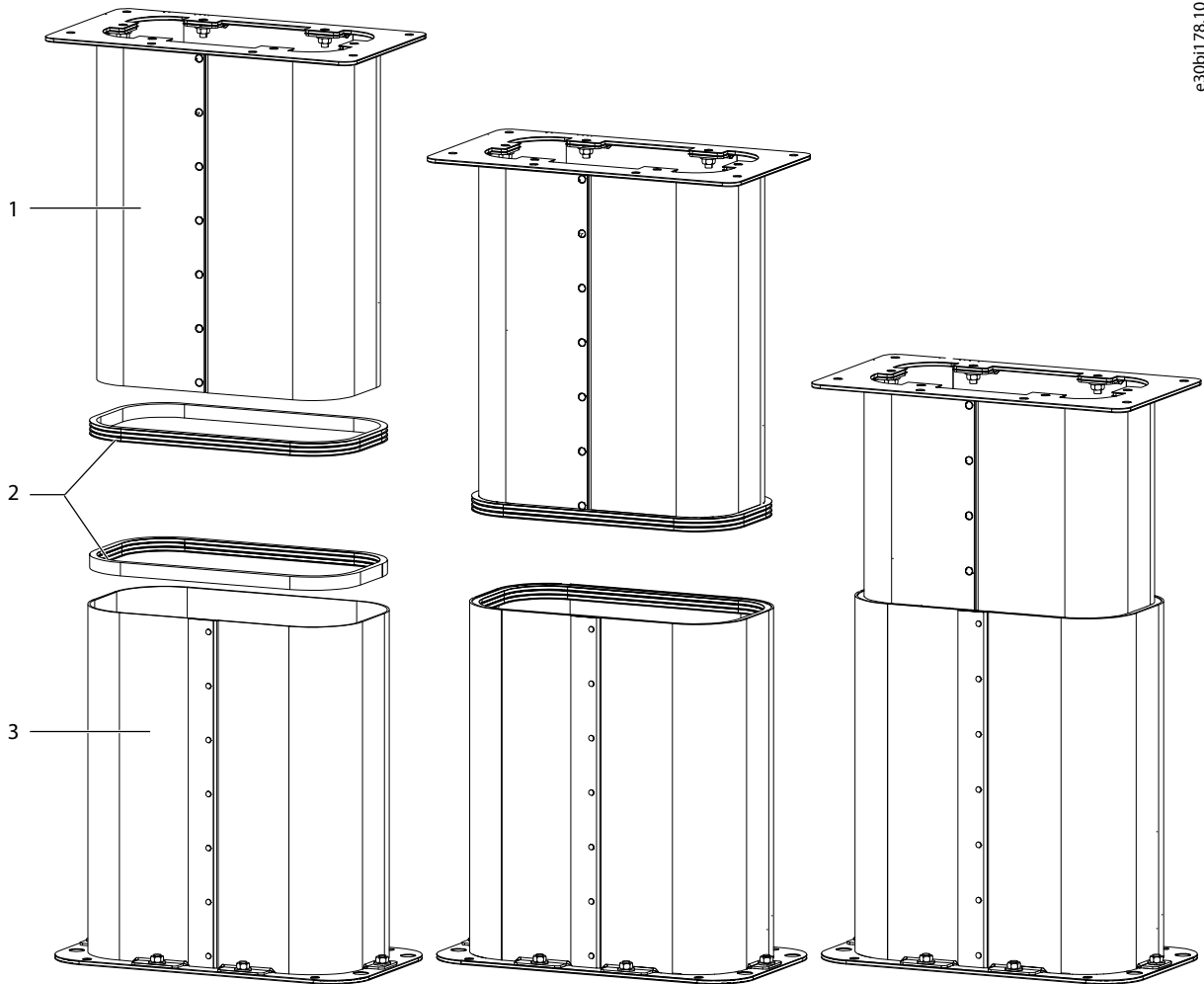

e30bj178.10

Illustration 12: Assembly of Telescopic Duct

1	Inner sleeve of duct	3	Outer sleeve of duct
2	Ribbed EPDM rubber seal		

## 2.10 Installing the Bottom Duct

To attach the bottom duct to the base plate of the cabinet, use the following steps. Refer to [Illustration 13](#).

### Procedure

- Install the base plate in the Rittal cabinet using the existing fasteners.
- Collapse the bottom duct and position it over the vent cutout in the base plate.
- Place the holes in the lower flange of the duct over the holes surrounding the opening in the plate.
- Fasten 4 M5x10 screws (T25) through the holes in the lower flange of the duct, securing it to the base plate.

5. Extend the duct upward and fasten with 6 M5 hex nuts, securing it to the duct support plate.

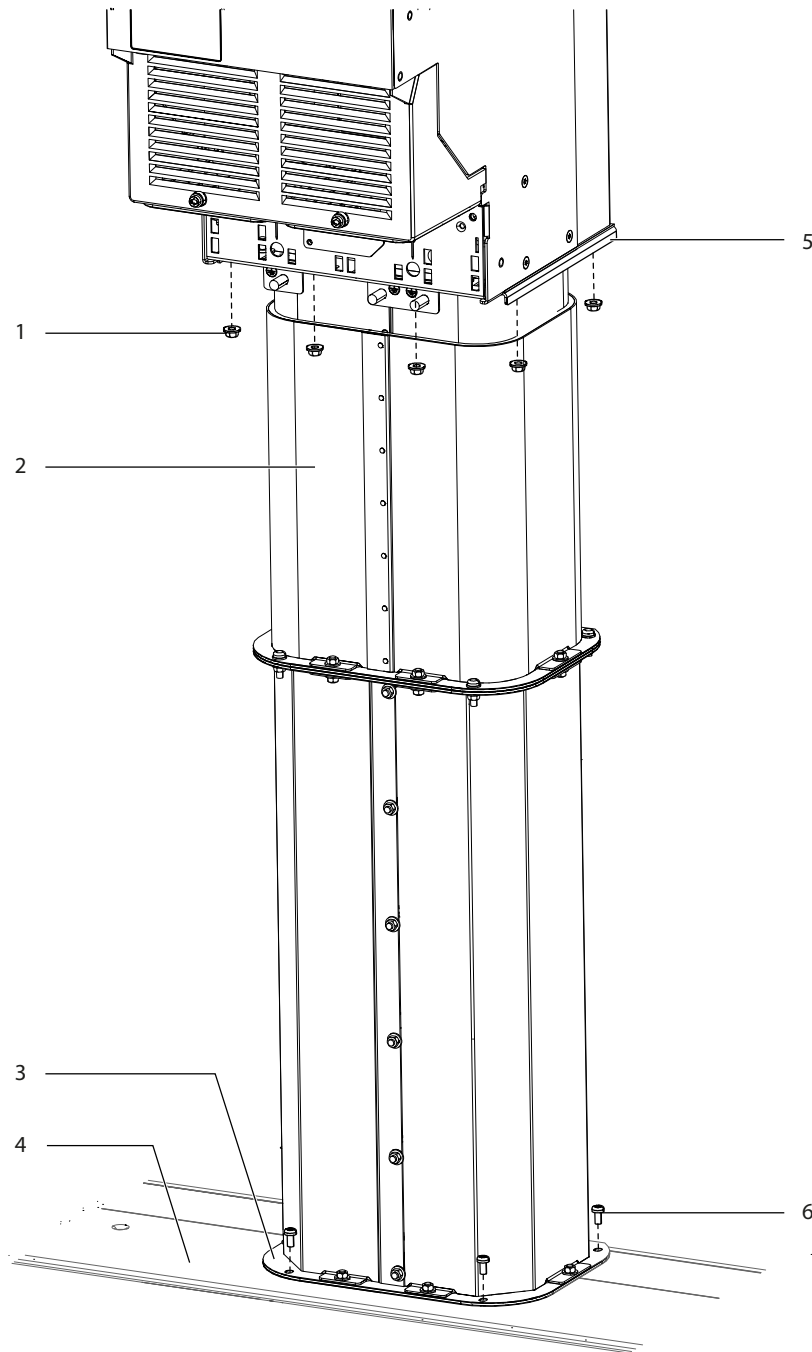

e30bj142.10

Illustration 13: Installation of the Bottom Duct

1	M5 hex nut	4	Base plate
2	Bottom telescopic duct	5	Duct support plate
3	M5x16 screw	6	Lower flange of duct

### 2.11 Installing the Back Vent

To install the back vent, use the following steps. Refer to [Illustration 14](#).

**Procedure**

1. Slide 6 clip-on nuts over the edge of the vent opening in the backplate of the cabinet.
2. Seat the clip-on nuts into the 6 holes around the opening.
3. Affix 2 back vent gaskets to the flange of the back vent, placing 1 gasket on the inner side and 1 gasket on the outer side of the flange.
4. Slide the back vent into the opening in the back plate.
5. Fasten the M6x12 screws around the inner edge of the back vent.

The FA09 kit requires 6 screws, and the FA10 kit requires 8 screws.

6. Secure the M5x18 screws in the flange of the back vent, attaching the vent to the back plate.

The FA09 kit requires 6 screws, and the FA10 kit requires 8 screws.

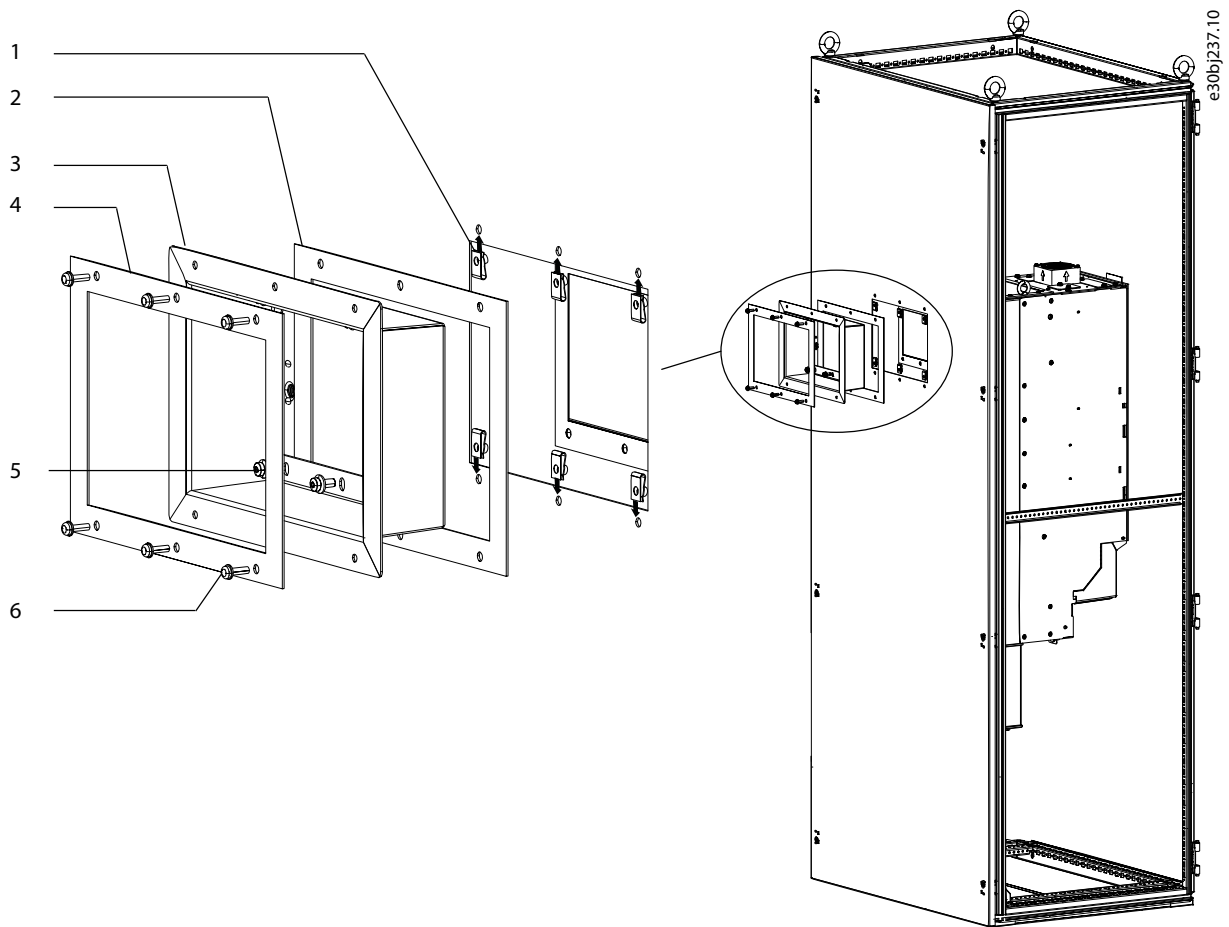

**Illustration 14: Installation of Back Vent**

1	Clip-on nut	4	Back vent gasket (outer)
2	Back vent gasket (inner)	5	M6x12 screw
3	Back vent	6	M5x18 screw





**Danfoss A/S**  
Ulsnaes 1  
DK-6300 Graasten  
[drives.danfoss.com](http://drives.danfoss.com)

Any information, including, but not limited to information on selection of product, its application or use, product design, weight, dimensions, capacity or any other technical data in product manuals, catalogues descriptions, advertisements, etc. and whether made available in writing, orally, electronically, online or via download, shall be considered informative, and is only binding if and to the extent, explicit reference is made in a quotation or order confirmation. Danfoss cannot accept any responsibility for possible errors in catalogues, brochures, videos and other material. Danfoss reserves the right to alter its products without notice. This also applies to products ordered but not delivered provided that such alterations can be made without changes to form, fit or function of the product. All trademarks in this material are property of Danfoss A/S or Danfoss group companies. Danfoss and the Danfoss logo are trademarks of Danfoss A/S. All rights reserved.

