



130R1378

VLT® HVAC Basic Drive FC 101

IEC/UL61800-5-1 Compliance

1 Introduction

This operating guide provides necessary information for qualified personnel to install and commission the AC drive. Read and follow the instructions to use the drive safely and professionally.

Do not dispose of equipment containing electrical components together with domestic waste. Collect it separately in accordance with local and currently valid legislation.

2 Safety

Pay particular attention to the safety instructions and general warnings to avoid the risk of death, serious injury, and equipment or property damage.

WARNING

HIGH VOLTAGE

AC drives contain high voltage when connected to AC mains input, DC supply, or load sharing.

UNINTENDED START

The motor may start from control panel, I/O inputs, fieldbus, or VLT® Motion Control Tool MCT 10 at any time, when the drive is connected to the AC mains, DC supply, or load sharing.

DISCHARGE TIME

The drive contains DC-link capacitors, which can remain charged even when the drive is not powered. High voltage can be present even when the warning indicator lights are off.

- Stop the motor, disconnect AC mains and permanent magnet type motors, and remove DC-link supplies, including battery backups, UPS, and DC-link connections to other drives.
- Wait for the capacitors to discharge fully and measure it before performing any service or repair work.
- The minimum waiting time is 4 minutes for H1, H2, and H3 drives, and 15 minutes for H4 and H5 drives.

LEAKAGE CURRENT

Leakage currents of the drive exceed 3.5 mA. Make sure that the minimum size of the ground conductor complies with the local safety regulations for high touch current equipment.

NOTICE

It is not allowed to install FC101 types with UL61800-5-1 in an isolated mains source (IT mains or floating delta) or TT/TN-S mains with a grounded leg (grounded delta).

3 Installation

3.1 Product Label

1. Product name
2. Type code (The 23rd digit of the type code is 6 indicates the drive complies with UL61800-5-1.)
3. Code number and serial number
4. Voltage, frequency, and current
5. Enclosure type, IP rating, and Efficiency data
6. Warnings and compliance information
7. Company name and address

Illustration 1: Product Label (Example)

3.2 Mechanical Dimensions

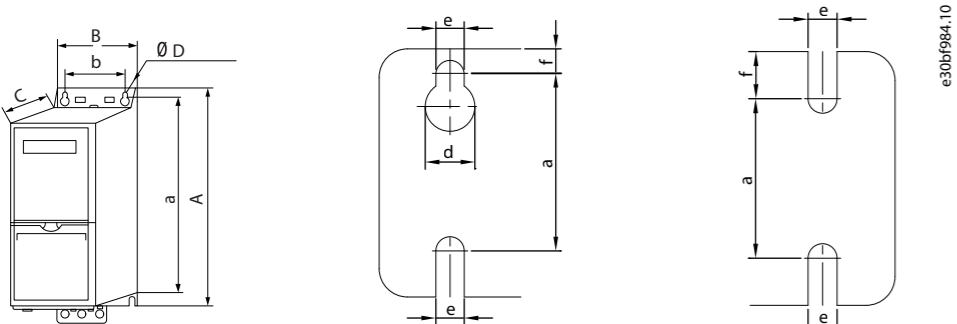

Illustration 2: Mechanical Dimensions

Table 1: Mechanical Dimensions, Enclosure Sizes H1-H5

Enclosure Size		H1	H2	H3	H4	H5
IP class		IP20	IP20	IP20	IP20	IP20
Power [kW (hp)]	3x200-240 V	0.25-1.5 (0.33-2.0)	2.2 (3.0)	3.7 (5.0)	5.5-7.5 (7.5-10)	11 (15)
	3x380-480 V	0.37-1.5 (0.5-2.0)	2.2-4.0 (3.0-5.0)	5.5-7.5 (7.5-10)	11-15 (15-20)	18.5-22 (25-30)
Height [mm (in)]	A	195 (7.7)	227 (8.9)	255 (10.0)	296 (11.7)	334 (13.1)
	A ⁽¹⁾	273 (10.7)	303 (11.9)	329 (13.0)	359 (14.1)	402 (15.8)
	a	183 (7.2)	212 (8.3)	240 (9.4)	275 (10.8)	314 (12.4)
Width [mm (in)]	B	75 (3.0)	90 (3.5)	100 (3.9)	135 (5.3)	150 (5.9)
	b	56 (2.2)	65 (2.6)	74 (2.9)	105 (4.1)	120 (4.7)
Depth [mm (in)]	C	168 (6.6)	190 (7.5)	206 (8.1)	241 (9.5)	255 (10)
Mounting hole [mm (in)]	d	9 (0.35)	11 (0.43)	11 (0.43)	12.6 (0.50)	12.6 (0.50)
	e	4.5 (0.18)	5.5 (0.22)	5.5 (0.22)	7 (0.28)	7 (0.28)
	f	5.3 (0.21)	7.4 (0.29)	8.1 (0.32)	8.4 (0.33)	8.5 (0.33)
Maximum weight kg (lb)		2.7 (6.0)	4.0 (8.8)	5.1 (11.2)	8.5 (18.7)	10.1 (22.3)

Note: (1) Including decoupling plate.

3.3 Connecting to Mains and Motor

1. Mount the ground cables to the ground terminal.
2. Connect the motor to terminals U, V, and W, and then tighten the screws according to the torques.
3. Connect the mains supply to terminals L1, L2, and L3, and then tighten the screws according to the torques described in the drive's design guide.

3.4 Relays and Terminals

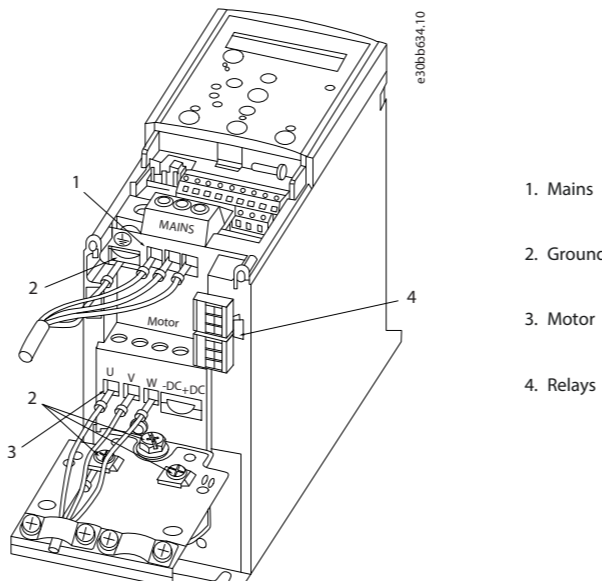

Illustration 3: Enclosure Sizes H1-H5, IP20, 200-240 V, 0.25-11 kW (0.33-15 hp), IP20, 380-480 V, 0.37-22 kW (0.5-30 hp)

NOTICE

Terminals +DC and -DC are protected by factory installed load share terminal insert which must NOT be removed.

3.5 Control Terminals

- Remove the terminal cover to access the control terminals.
- Use a flat-edged screwdriver to push down the lock lever of the terminal cover under the LCP, then remove the terminal cover as shown in illustration 4 Removing the Terminal Cover.

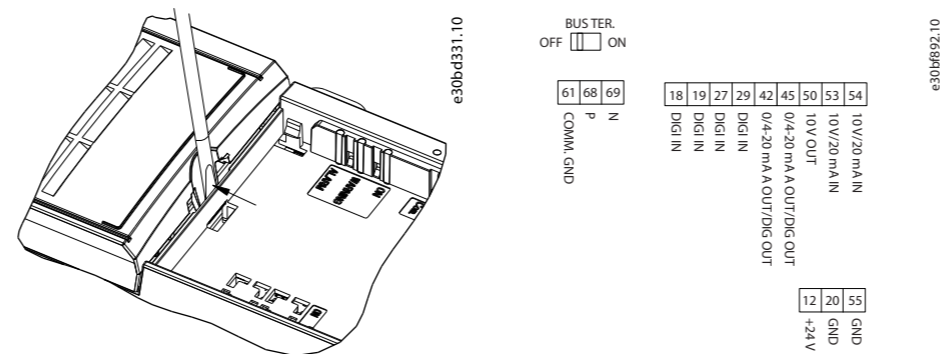

Illustration 4: Removing the Terminal Cover

Illustration 5: Control Terminals

Illustration 5 Control Terminals shows all the drive control terminals. Applying start (terminal 18), connection between terminals 12-27, and an analog reference (terminal 53 or 54, and 55) make the drive run. The digital input mode of terminal 18, 19, and 27 is set in parameter 5-00 Digital Input Mode (PNP is default value). Digital input 29 mode is set in parameter 5-03 Digital Input 29 Mode (PNP is default value).

4 Programming

4.1 Local Control Panel (LCP)

The drive can be programmed from the LCP or from a PC via the RS485 COM port by installing the MCT 10 Setup Software. The LCP is divided into 4 functional sections.

- A. Display
- B. Menu key
- C. Navigation keys and indicator lights
- D. Operation keys and indicator lights

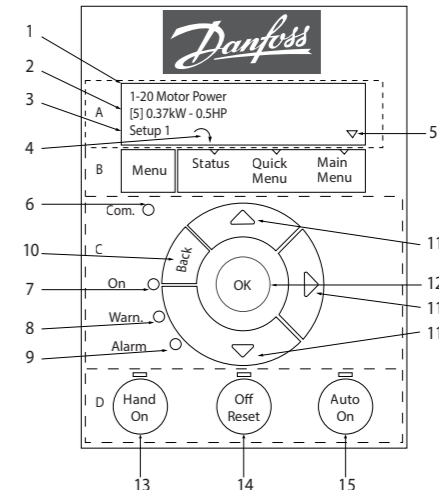

Illustration 6: Local Control Panel (LCP)

A. Display

The LCD-display is illuminated with 2 alphanumeric lines. All data is shown on the LCP. The illustration 6 Local Control Panel (LCP) describes the information that can be read from the display.

Table 2: Legend to Section A

1	Parameter number and name.
2	Parameter value.
3	Setup number shows the active setup and the edit setup. If the same setup acts as both active and edit setup, only that setup number is shown (factory setting). When active and edit setup differ, both numbers are shown in the display (setup 12). The number flashing indicates the edit setup.
4	Motor direction is shown to the bottom left of the display – indicated by a small arrow pointing either clockwise or counter-clockwise.
5	The triangle indicates if the LCP is in Status, Quick Menu, or Main Menu.

B. Menu Key

Press [Menu] to select among Status, Quick Menu, or Main Menu.

C. Navigation keys and indicator lights

Table 3: Legend to Section C

6	Com. LED: Flashes during bus communication.
7	Green LED/On: Control section is working correctly.
8	Yellow LED/Warn.: Indicates a warning.
9	Flashing Red LED/Alarm: Indicates an alarm.
10	[Back]: For moving to the previous step or layer in the navigation structure.
11	[▲] [▼] [▶]: For navigating among parameter groups and parameters, and within parameters. They can also be used for setting local reference.
12	[OK]: For selecting a parameter and for accepting changes to parameter settings.

D. Operation keys and indicator lights

Table 4: Legend to Section D

13	[Hand On]: Starts the motor and enables control of the drive via the LCP.
NOTICE	
	[2] Coast inverse is the default option for parameter 5-12 Terminal 27 Digital Input. If there is no 24 V supply to terminal 27, [Hand On] does not start the motor. Connect terminal 12 to terminal 27.
14	[Off/Reset]: Stops the motor (Off). If in alarm mode, the alarm is reset.
15	[Auto On]: The drive is controlled either via control terminals or serial communication.

4.2 Automatic Motor Adaptation (AMA)

Via running AMA in VVC+ mode, the drive builds a mathematical model of the motor to optimize compatibility between drive and motor, and thus enhances the motor control performance.

Procedure:

1. Set motor data according to the motor nameplate.
2. If needed, set motor cable length in parameter 1-42 Motor Cable Length.
3. Select [1] Enable Complete AMA or [2] Enable Reduced AMA in parameter 1-29 Automatic Motor Adaption (AMA), and press [Hand On] to activate the AMA function. After a normal sequence, the display shows: Press [OK] to finish AMA.
4. Press [OK], then the drive is ready for operation.

