

(268.45)

(415)

SCALE 1:1

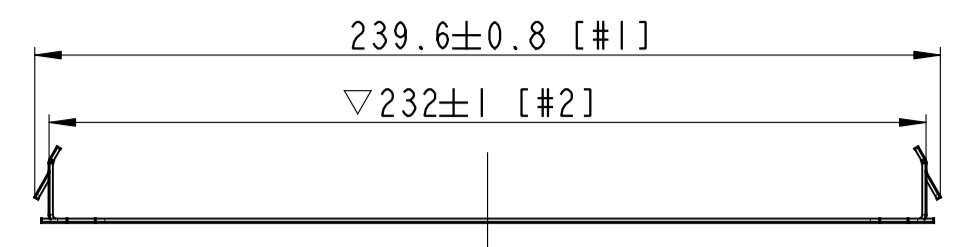

A

[#17]
Barcode label type 39
with part number, revision and
supplier identification

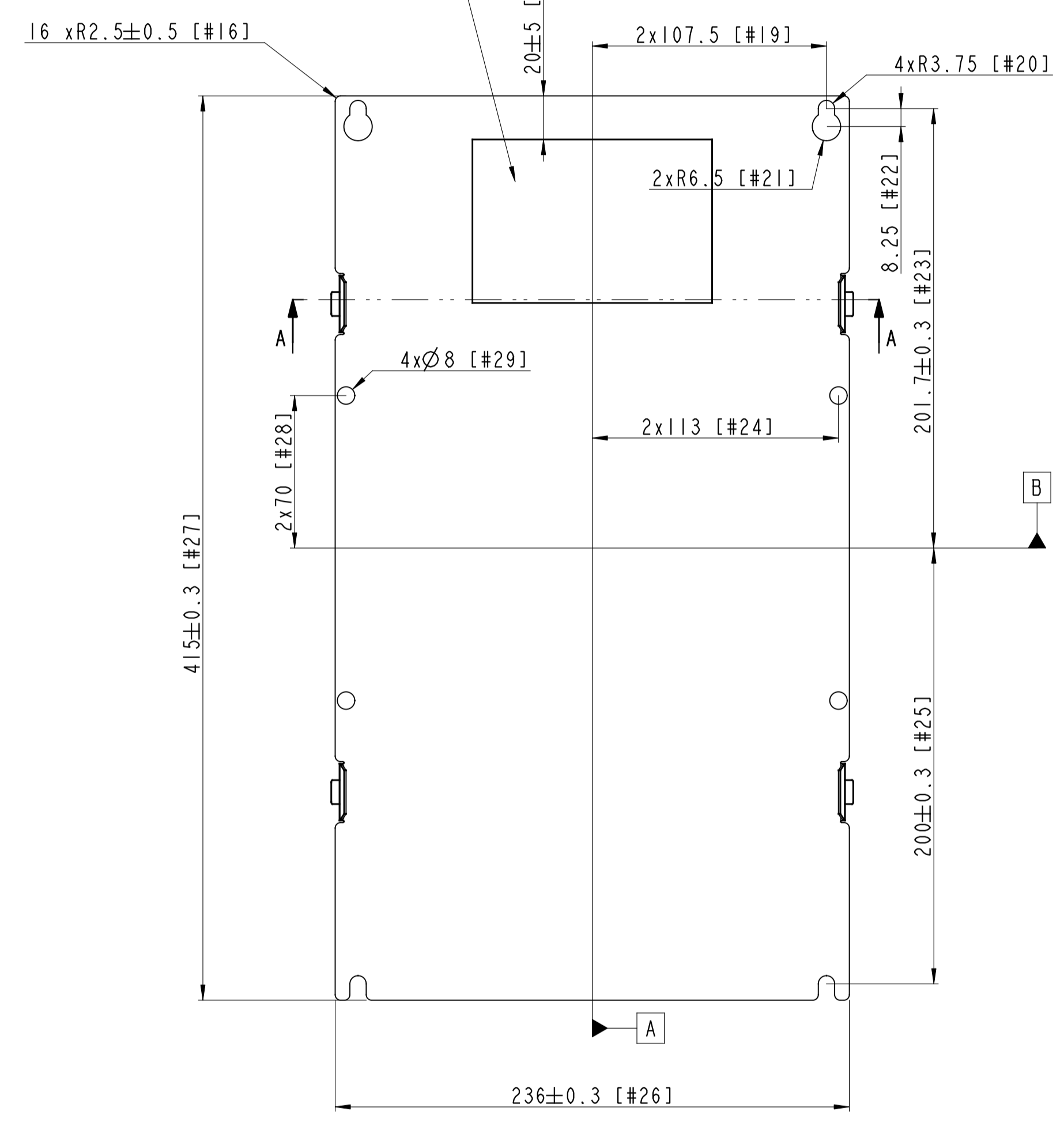

A

B

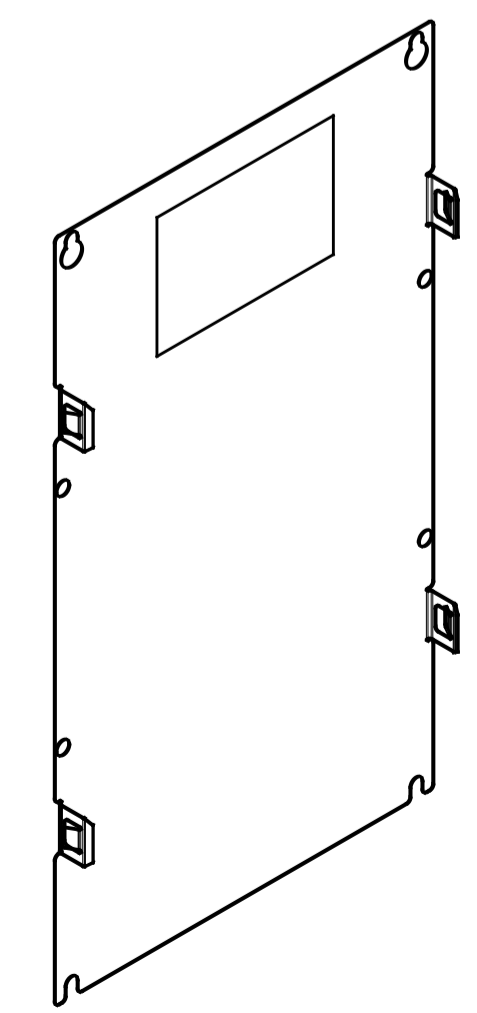

SCALE 3:10

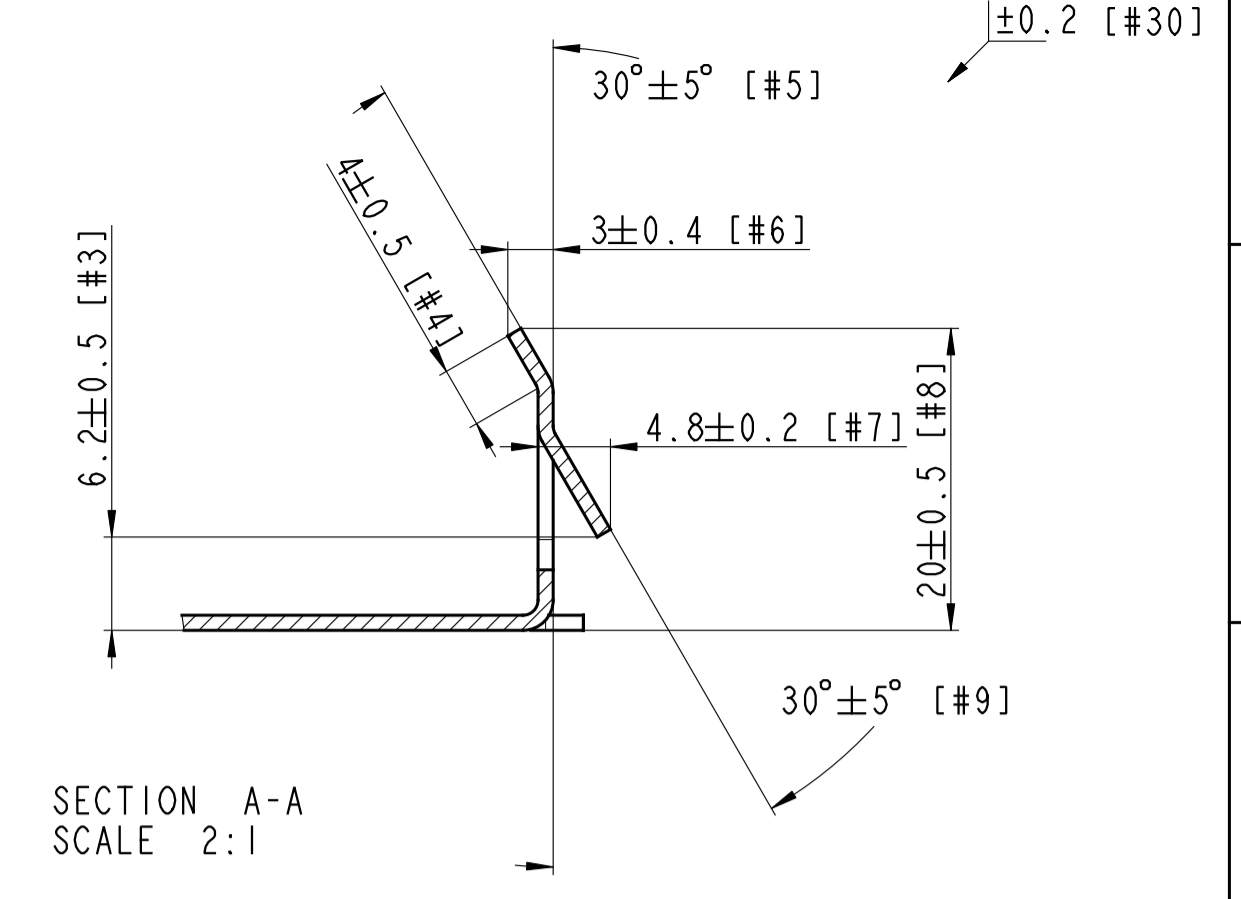

SECTION A-A
SCALE 2:1

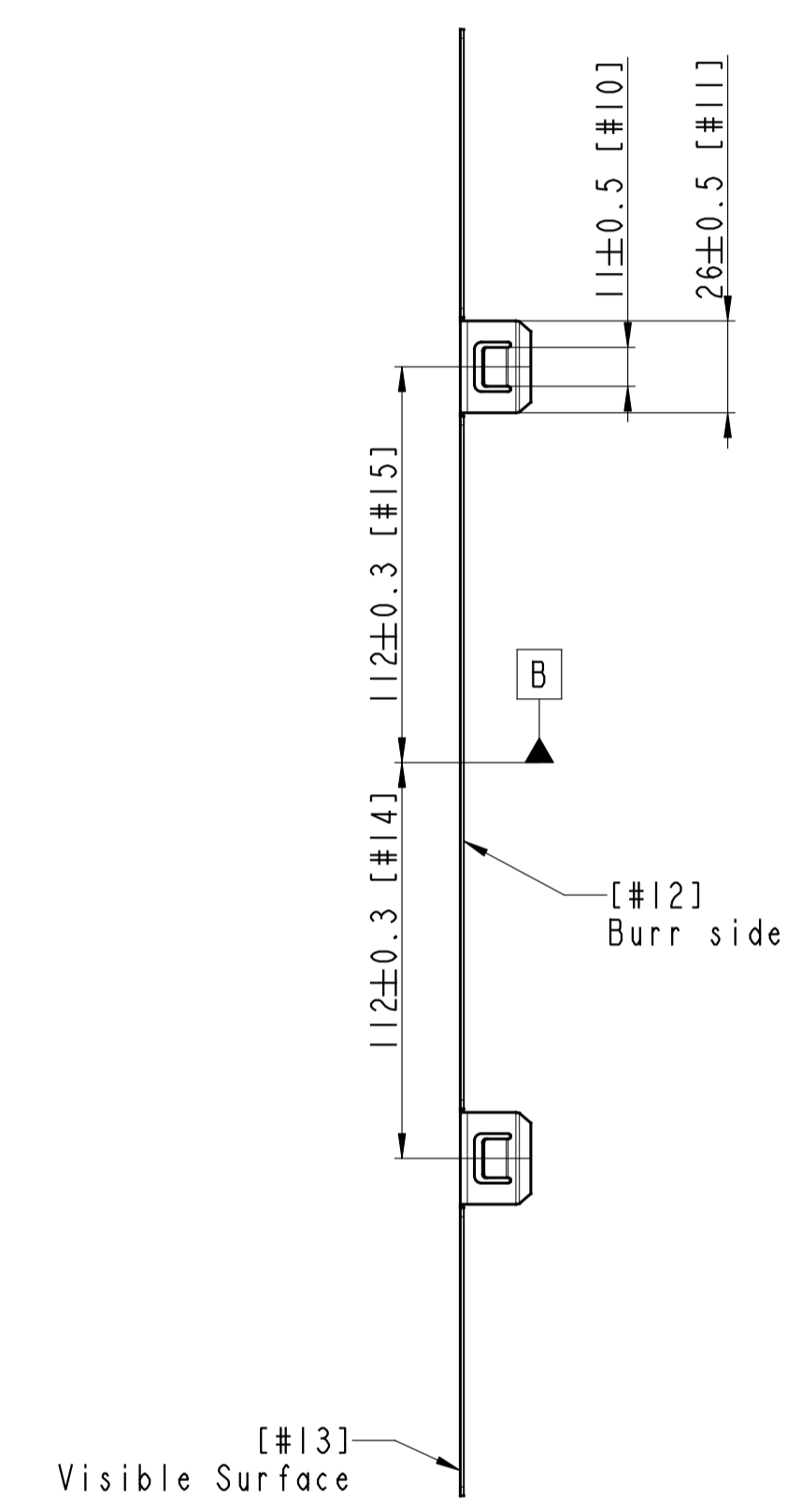

[#13]
Visible Surface

▽Critical Characteristic dimension no.#2
 General inner bending radius : MAX. 1 mm
 Datums A & B are both centered in height and width respectively
 Tolerances for not specified dimensions: ±0.2
 Corner rounds not specified: R0.5±0.2
 Burrs must be removed and sharp edges must be polish
 Part must be washed and degreased
 No impact marks are acceptable
 Scratches to be avoided on visible surfaces
 Material specification:
 1 mm Sheet acc. EN 10215 DX51D+AZ150-A-C
 Not specified dimensions according to unfolded part
 Part weight : 0.78 Kg
 Has to comply with RoHS directive

PDM controlled drawing. Hard copy not valid without frozen date in ID Stamp		Projection 	Scale 1:2	Size A1	Material See Note
Replace	Designation / Name				
Designer A.Godinho 2013-08-14	 Backplate IP55 A5				
Confidential: Property of Danfoss Power Electronics A/S, Grasten, Denmark. Not to be handed over to, copied or used by third party. Two- or three dimensional reproduction of contents to be authorized by Danfoss Power Electronics A/S.		No.	130B3228	Rev.	009
		Sheet 1 of 1		Made in: 130B3228 PART	