



Operating Guide

VLT[®] Decentral Drive FCD 302



Contents

1 Introduction	3
1.1 Introduction	3
1.2 Safety	3
1.3 Purpose of the Manual	4
1.4 Additional Resources	4
1.5 Product Overview	5
1.6 Internal Frequency Converter Controller Functions	5
1.7 Type Code Description	6
2 Installation	8
2.1 Check List	8
2.2 Exploded View of the FCD 302	9
2.3 Mechanical Installation	11
2.3.1 Recommended Tools and Equipment	11
2.3.2 Mechanical Dimensions	11
2.3.3 Cooling	11
2.3.4 Mounting	12
2.3.4.1 Hygienic Installation	13
2.3.4.2 Cleaning	13
2.3.5 Tightening Torques	13
2.4 Electrical Installation	13
2.4.1 Requirements	15
2.4.2 Location of Terminals	17
2.4.3 Terminal Types	18
2.4.4 Motor Connection	18
2.4.5 Control Wiring	19
2.4.6 AC Mains Input Connection	20
2.4.7 Motor and Mains Connection with Service Switch	20
2.4.8 Brake Resistor	20
2.4.9 Mechanical Brake	21
2.4.10 Connection of Sensors/Actuators on M12 Sockets	21
2.4.11 Earth (Grounding) Requirements	21
2.4.12 Grounding of Screened Control Cables	24
2.4.13 DIP Switches	25
2.4.14 Serial Communication	25
2.4.15 Connection to PC	25
2.4.16 Safe Stop	26
3 Start Up and Functional Testing	27
3.1 Pre-start	27

3.1.1 Safety Inspection	27
3.1.2 Start Up Check List	28
3.2 Applying Power to the Frequency Converter	29
3.3 Quick Setup	29
3.4 Automatic Motor Adaptation	30
3.5 Local-control Test	30
3.6 System Start Up	31
4 User Interface	32
4.1 Local Control Panel	32
4.1.1 LCP Layout	32
4.1.2 Setting LCP Display Values	32
4.1.3 Display Menu Keys	33
4.1.4 Navigation Keys	34
4.1.5 Operation Keys	34
4.2 Back Up and Copying Parameter Settings	34
4.2.1 Uploading Data to the LCP	35
4.2.2 Downloading Data from the LCP	35
4.3 Restoring Default Settings	35
4.3.1 Recommended Initialization	35
4.3.2 Manual Initialization	35
5 Programming	36
5.1 Introduction	36
5.2 Quick Setup	36
5.3 Parameter Lists	40
5.4 Remote Programming with MCT 10 Set-up Software	59
6 Status Indication	60
6.1 Frontal LEDs	60
6.2 Status Display	60
6.3 Status Message Definitions	61
7 Troubleshooting	63
7.1.1 Warnings/Alarm Messages	63
8 Specifications	72
8.1 Electrical Data and Wire Sizes	72
8.1.2 UL/cUL Approved Pre-fuses	73
8.1.3 FCD 302 DC Voltage Levels	73
8.2 General Specifications	74
Index	79

1 Introduction

1.1 Introduction

1.1.1 Approvals



1.1.2 Symbols

The following symbols are used in this manual:

▲WARNING

Indicates a potentially hazardous situation that could result in death or serious injury.

▲CAUTION

Indicates a potentially hazardous situation that could result in minor or moderate injury. It can also be used to alert against unsafe practices.

NOTICE

Indicates important information, including situations that can result in damage to equipment or property.

Conventions

Numbered lists indicate procedures.

Bullet lists indicate other information and description of illustrations.

Italicized text indicates:

- Cross-reference.
- Link.
- Footnote.
- Parameter name, parameter group name, parameter option.

All dimensions in drawings are in mm (in).

* Indicates a default setting of a parameter.

VLT® is a registered trademark.

EtherNet/IP™ is a trademark of ODVA, Inc.

1.2 Safety

▲WARNING

HIGH VOLTAGE

Frequency converters contain high voltage when connected to AC mains input, DC supply, or load sharing. Failure to perform installation, start-up, and maintenance by qualified personnel can result in death or serious injury.

- Only qualified personnel must perform installation, start-up, and maintenance.

▲WARNING

UNINTENDED START

When the frequency converter is connected to AC mains, DC supply, or load sharing, the motor may start at any time. Unintended start during programming, service, or repair work can result in death, serious injury, or property damage. The motor can start with an external switch, a fieldbus command, an input reference signal from the LCP or LOP, via remote operation using MCT 10 Set-up Software, or after a cleared fault condition.

To prevent unintended motor start:

- Press [Off/Reset] on the LCP before programming parameters.
- Disconnect the frequency converter from the mains.
- Completely wire and assemble the frequency converter, motor, and any driven equipment before connecting the frequency converter to AC mains, DC supply, or load sharing.

⚠ WARNING**DISCHARGE TIME**

The frequency converter contains DC-link capacitors, which can remain charged even when the frequency converter is not powered. High voltage can be present even when the warning LED indicator lights are off. Failure to wait the specified time after power has been removed before performing service or repair work can result in death or serious injury.

- Stop the motor.
- Disconnect AC mains and remote DC-link power supplies, including battery back-ups, UPS, and DC-link connections to other frequency converters.
- Disconnect or lock PM motor.
- Wait at least 4 minutes for the capacitors to discharge fully.
- Before performing any service or repair work, use an appropriate voltage measuring device to make sure that the capacitors are fully discharged.

⚠ CAUTION**RISK OF INJURY OR PROPERTY DAMAGE**

Do not assume that a motor is wired properly after completed service of the frequency converter.

Check for:

- Loose connections.
- Improper programming.
- Added equipment.

Failure to perform these checks can result in personal injury, property damage, or less than optimal performance.

⚠ WARNING**REPAIR WORK**

In the event of an error, alarm or warning, refer to *chapter 7 Troubleshooting*. Before commencing repair work, contact Danfoss Service.

NOTICE**PELV COMPLIANCE**

All control terminals and relay terminals 01-03/04-06 comply with PELV (Protective Extra Low Voltage). However, in grounded delta configuration above 400 V, the frequency converter is not PELV-compliant.

1.3 Purpose of the Manual

This manual is intended to provide detailed information for the installation and start up of the frequency converter. *Chapter 2 Installation* provides details of mechanical and electrical installation. *Chapter 3 Start Up and Functional Testing* provides detailed procedures for startup and functional testing. The remaining chapters provide supplementary details. These include user interface, basic operational concepts, programming and application examples, start up troubleshooting, and equipment specifications.

Optional equipment is available that can change some of the procedures described. Be sure to see the instructions supplied with those options for specific requirements.

1.4 Additional Resources

Other resources are available to understand advanced frequency controller functions and programming.

- The *VLT® Decentral Drive FCD 302 Programming Guide*, provides greater detail in how to work with parameters and many application examples.
- The *VLT® Decentral Drive FCD 302 Design Guide*, is intended to provide detailed capabilities and functionality to design motor control systems.
- *VLT® Installation Instructions*.
- *VLT® Installation Instructions*.
- *VLT® Safe PLC Interface Option Installation Instructions*.
- Fieldbus manuals:
 - *VLT® PROFIBUS DP MCA 101 Programming Guide*.
 - *VLT® PROFIBUS DP MCA 101 Installation Instructions*.
 - *VLT® EtherNet/IP MCA 121 Programming Guide*.
 - *VLT® EtherNet/IP MCA 121 Installation Instructions*.
 - *VLT® PROFINET MCA 120 Programming Guide*.
 - *VLT® PROFINET MCA 120 Installation Instructions*.
- *VLT® Brake Resistor MCE 101 Design Guide*.
- Training courses both on-line and in person.
- Hotline, telephone and on-line help.
- Installation, set up, and commissioning is also available by Danfoss trained and approved installers.

- Danfoss sales representatives are also trained to provide customer service and instruction for applications.

Contact your Danfoss supplier or go to www.Danfoss.com for downloads or additional information.

1.5 Product Overview

A frequency converter is an electronic motor controller that converts AC mains input into a variable AC waveform output. The frequency and voltage of the output are regulated to control the motor speed or torque.

In addition, the frequency converter monitors the system and motor status, issues warnings or alarms for fault conditions, starts and stops the motor, optimizes energy efficiency, provides line harmonics protection, and offers many more control, monitoring, and efficiency functions. Operation and monitoring functions are available as status indications to an outside control system or serial communication network.

The VLT® Decentral Drive FCD 302 is designed for decentral mounting, for example, in the food and beverage industry, or for other material handling applications. With the FCD 302 it is possible to reduce costs by placing the power electronics decentrally. Central panels are then rendered obsolete, saving cost, space and effort for installation and wiring. The basic design is service-friendly, with a pluggable electronic part and a flexible and “spacious” wiring box. It is easy to change electronics without the need for re-wiring.

1.6 Internal Frequency Converter Controller Functions

Below is a block diagram of the internal components of the frequency converter. See *Table 1.1* for their functions.

Area	Title	Functions
1	Mains input	Three-phase AC mains power supply to the frequency converter.
2	Rectifier	The rectifier bridge converts the AC input to DC current for use within the frequency converter.
3	DC bus	The intermediate DC-bus circuit of the frequency converter handles the DC current for internal routing.
4	DC line reactors	<ul style="list-style-type: none"> • Filter the intermediate DC circuit voltage • Provide line transient protection • Reduce RMS current • Raise the power factor reflected back to the line • Reduce harmonics on the AC input
5	Capacitor bank	<ul style="list-style-type: none"> • Stores the DC power • Provides a regulated DC current supply • Provides ride-through protection for short power losses
6	Inverter	The inverter converts the DC into a controlled PWM AC waveform for a controlled variable output to the motor.
7	Output to motor	By controlling the voltage and frequency, the frequency converter provides regulated motor control from 0-50/60 Hz at 100% supply voltage.
8	Control circuitry	<ul style="list-style-type: none"> • Input power, internal processing, output, and motor current are monitored to provide efficient operation and control • User interface and external commands are monitored and performed • Status output and control can be provided

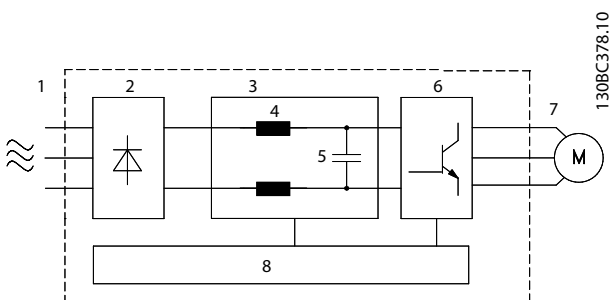

Illustration 1.1 Frequency Converter Block Diagram

Table 1.1 Frequency Converter Internal Components

1

1.7 Type Code Description

Position	1	2	3	4	5	6	7	8	9	10	11	12	13	14	15	16	17	18	19	20	21	22	23	24	25	26	27	28	29	30	31	32	33	34	35	36	37	39	39
	F	C	D	3	0	2	P				T	4				H	1											X	A		B		X	X	X	X	X	D	

130BB797.10

Position	Description	Choices/options	
01-03	Product group	FCD	Decentral Drive
04-06	Frequency converter series	302	Advanced performance
07-10	Power size	PK37	0.37 kW/0.5 HP
		PK55	0.55 kW/0.75 HP
		PK75	0.75 kW/1.0 HP
		P1K1	1.1 kW/1.5 HP
		P1K5	1.5 kW/2.0 HP
		P2K2	2.2 kW/3.0 HP
		P3K0	3.0 kW/4.0 HP (large unit only)
		PXXX	Installation box only (without power section)
11-12	Phases, Mains voltage	T	Three phase
		4	380-480 V AC
13-15	Enclosure	B66	Standard Black - IP66/Type 4X
		W66	Standard White - IP66/Type 4X
		W69	Hygienic White - IP66K/Type 4X
16-17	RFI filter	H1	RFI filter class A1/C2
18	Brake	X	No brake
		S	Brake chopper + mechanical brake Supply
19	Hardware configuration	1	Complete product, small unit, stand alone mount
		3	Complete product, large unit, stand alone mount
		X	Drive part, small unit (No installation box)
		Y	Drive part, large unit (No installation box)
		R	Installation box, small unit, stand alone mount (No drive part)
		T	Installation box, large unit, stand alone mount (No drive part)
20	Brackets	X	No brackets
		E	Flat brackets
		F	40 mm brackets
21	Threads	X	No installation box
		M	Metric threads
22	Switch option	X	No switch option
		E	Service switch on mains input
		F	Service switch on motor output
		H	Circuit breaker & mains disconnect, looping terminals (large unit only)
		K	Service switch on mains input with additional looping terminals (large unit only)
23	Display	X	No display connector (No installation box)
		C	With Display Connector
24	Sensor plugs	X	No sensor plugs
		E	Direct mount 4xM12: 4 digital inputs
		F	Direct mount 6xM12: 4 digital inputs, 2 relay outputs
25	Motor plug	X	No motor plug
26	Mains plug	X	No mains plug

Position	Description	Choices/options	
27	Fieldbus plug	X	No fieldbus plug
		E	M12 Ethernet
		P	M12 Profibus
28	Reserved	X	For future use
29–30	A option	AX	No A option
		A0	Profibus DP
		AN	Ethernet IP
		AL	ProfiNet
31–32	B option	BX	No B option
		BR	Encoder option
		BU	Resolver option
		BZ	Safety PLC Interface
33–37	Reserved	XXXXX	For future use
38–39	D option	DX	No D option
		D0	24 V DC back-up input

Illustration 1.2 Type Code Description

Not all choices/options are available for each FCD 302 variant. To verify if the appropriate version is available, consult the Drive Configurator on the Internet:
driveconfig.danfoss.com.

NOTICE

A and D options for FCD 302 are integrated into the control card. Do not use pluggable options for frequency converters. Future retrofit requires exchange of the entire control card. B options are pluggable, using the same concept as for frequency converters.

2

2 Installation

2.1 Check List

The packaging contains:

- Accessories bag, supplied only with order of installation box. Contents:
 - 2 cable clamps
 - Bracket for motor/loads cables
 - Elevation bracket for cable clamp
 - Screw M4x20 mm
 - Thread forming 3.5 mm x 8 mm
- Documentation
- Frequency converter

Depending on options fitted, the box will contain one or two bags and one or more booklets.

- When unpacking the frequency converter, ensure that the unit is undamaged and complete
- Compare model number of unit on the name plate to what was ordered, to verify the proper equipment.
- Ensure the mains (power) supply, frequency converter, and motor are rated for same voltage.

2.2 Exploded View of the FCD 302

130BC379.10

2

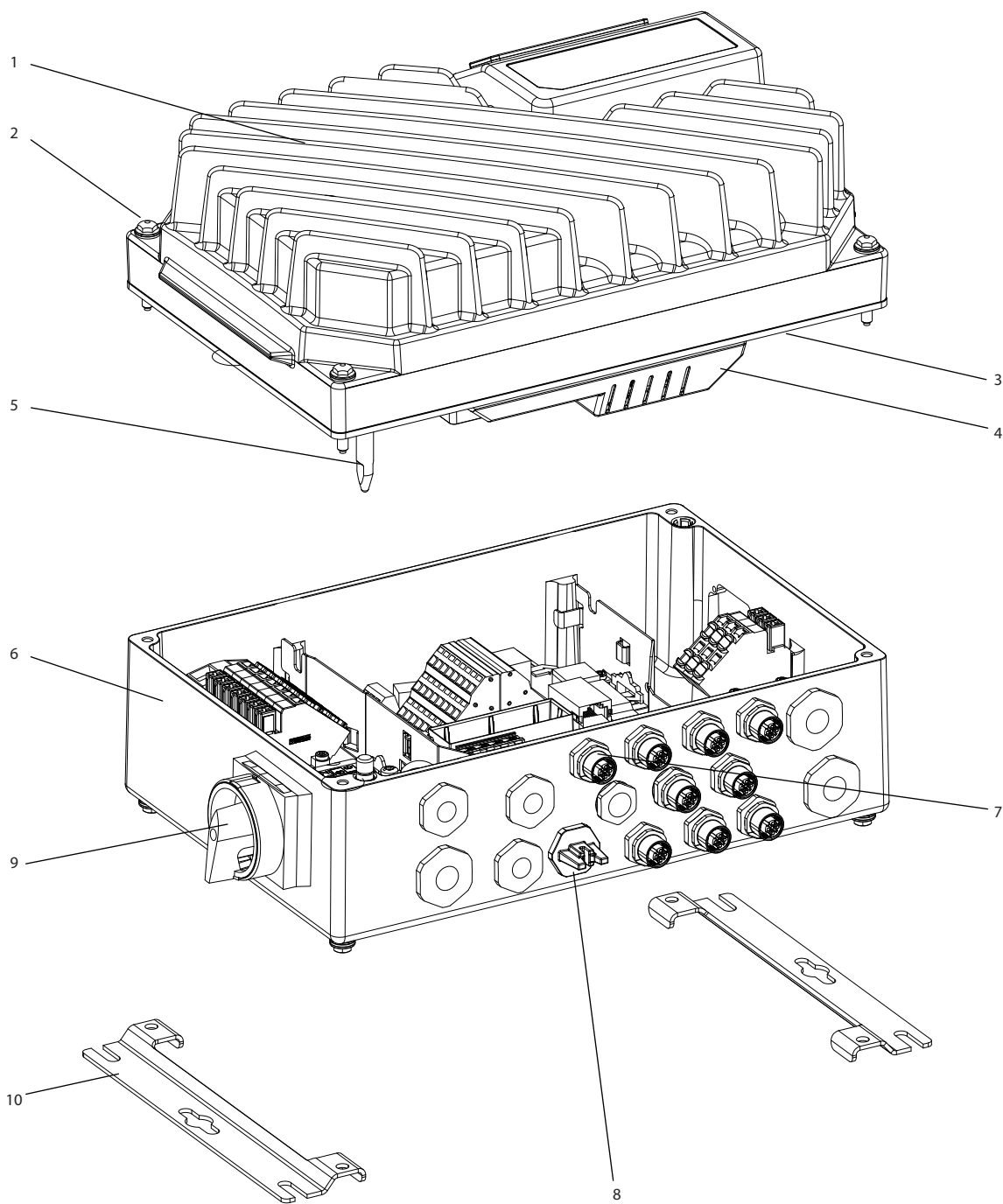

1	Inverter part	6	Installation box
2	Fastening screws (4 x, 1 in each corner)	7	Display connection
3	Sealing gasket	8	Access to USB port
4	Inverter part plastic cover	9	Service switch-motor side (alternatively, switch located on mains side, or not mounted)
5	Ground connection pin	10	Flat mounting brackets

Illustration 2.1 Exploded View Small Unit

2

130FC380.10

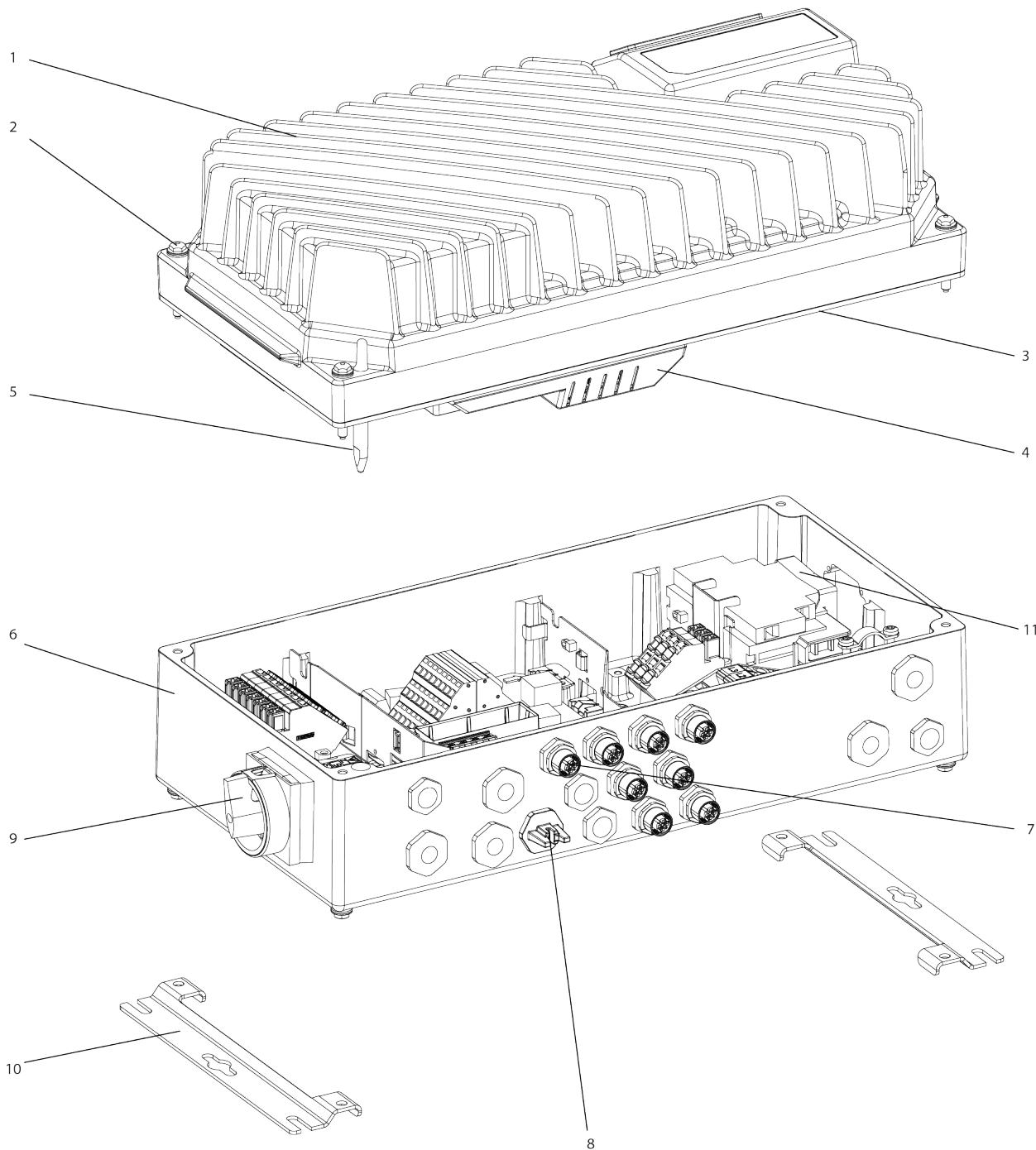

1	Inverter part	7	Display connection
2	Fastening screws (4 x, 1 in each corner)	8	Access to USB port
3	Sealing gasket	9	Service switch*-motor side (alternatively, switch located on mains side, or not mounted)
4	Inverter part plastic cover	10	Flat mounting brackets
5	Ground connection pin	11	Circuit breaker* (optional)
6	Installation box	*	The unit can be configured with either service switch or circuit breaker, not both. The illustration shown is not configurable in practice, but is displayed to show the respective positions of components only.

Illustration 2.2 Exploded View Large Unit

2.3 Mechanical Installation

2.3.1 Recommended Tools and Equipment

Equipment	Size	Description
Screwdrivers		
Socket (Hex)	8	For fastening inverter screws/ mounting of brackets
Slotted	0.4x2.5 mm	For spring loaded power and control terminals
Slotted/Torx	1.0x5.5 mm/ TX20	For cable clamps inside the installation box
Spanner	19, 24, 28 mm	For blind-plugs
LCP, part no. 130B1078		Local control panel
LCP cable, part no. 130B5776		Connection cable for local control panel

2.3.2 Mechanical Dimensions

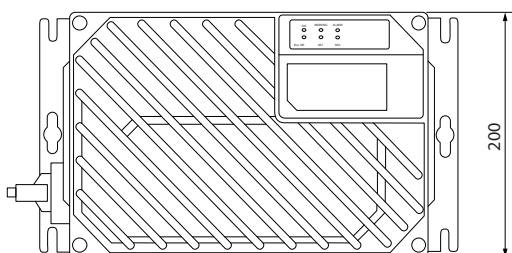
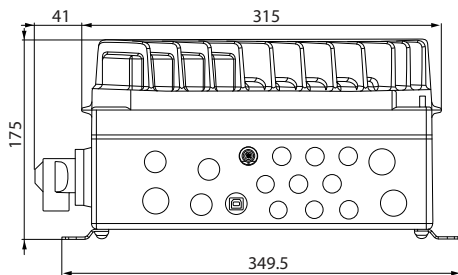
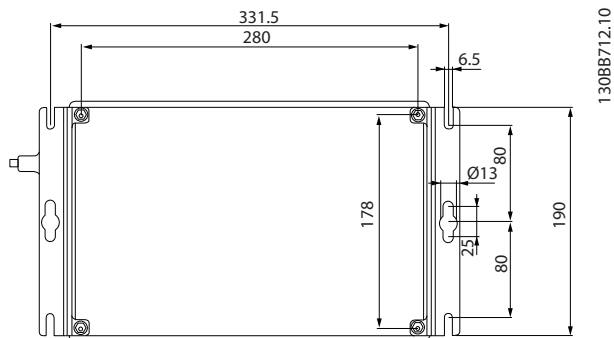

Illustration 2.3 Cable Entries and Hole Sizes (Small Unit)

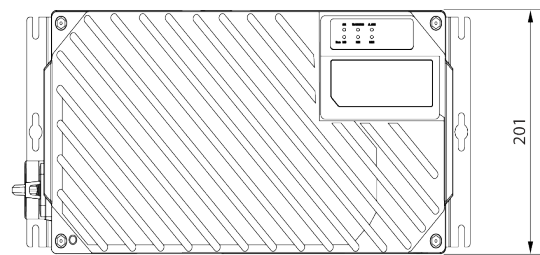
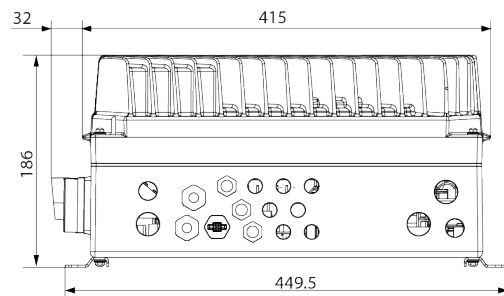
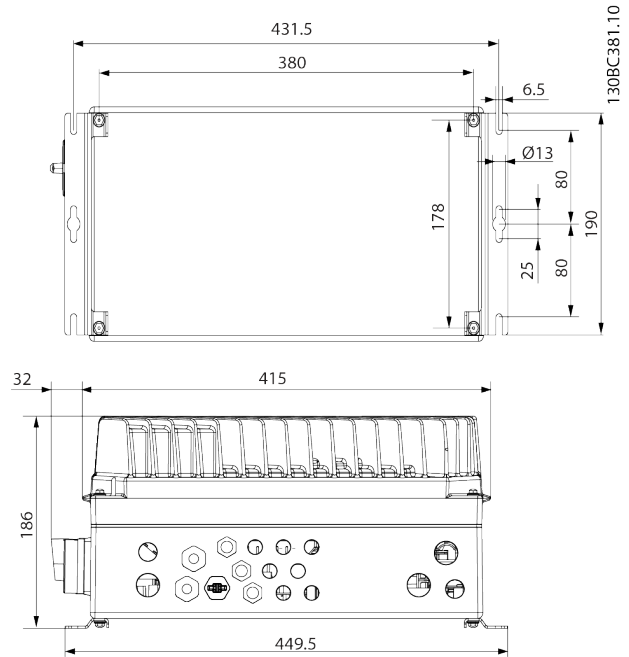

Illustration 2.4 Cable Entries and Hole Sizes (Large Unit)

Motor side	1xM20, 1xM25
Control side	2xM20, 9xM16 ¹⁾
Mains side	2xM25

1) Also used for 4xM12/6xM12 sensor/actuator sockets.

2.3.3 Cooling

The FCD 302 has no forced cooling. It relies only on natural convection for cooling using the cooling fins.

- A minimum of 100 mm (4 in) top and bottom air cooling clearance must be provided. See *Illustration 2.5*.
- Derating starts above 40 °C (104 °F) and 1000 m (3300 ft) elevation above sea level. See *FCD 302 Design Guide, MG04HXYY* for detailed information.

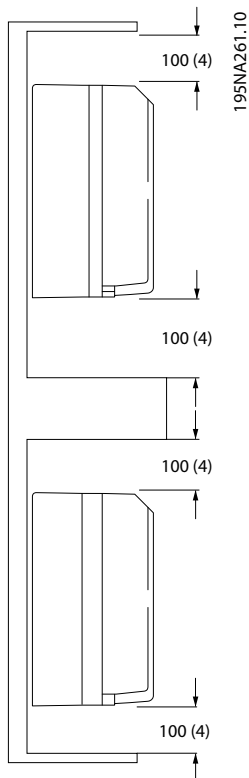

Illustration 2.5 Top and Bottom Cooling Clearance

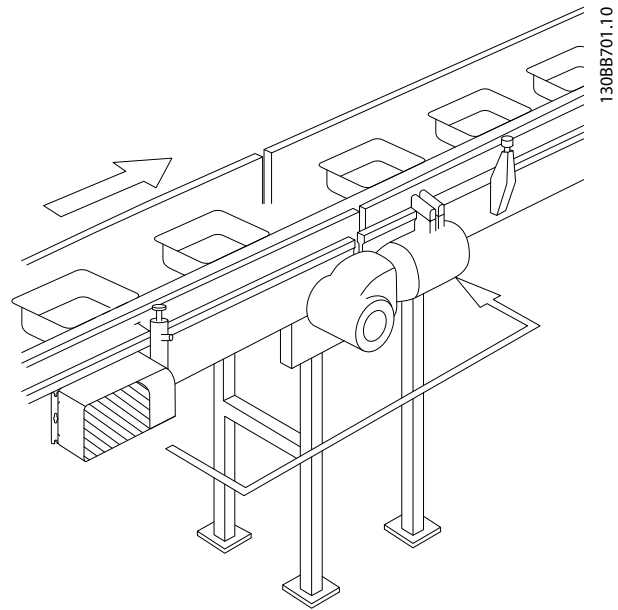

Illustration 2.6 FCD 302 Stand Alone Mounted with Mounting Brackets

2.3.4 Mounting

The FCD 302 consists of two parts: The installation box and the electronic part. See *chapter 2.2 Exploded View of the FCD 302*.

⚠ WARNING

LOOSE ELECTRONIC PART

Do not switch on the mains before the 4 screws are tightened. Failure to tighten these screws can result in personal injury or material damage when the unit is loaded.

Stand alone mounting

- The holes on the rear of the installation box are used to fix mounting brackets
- Ensure that the strength of the mounting location can support the unit weight
- Make sure that the proper mounting screws or bolts are used

Permitted mounting positions

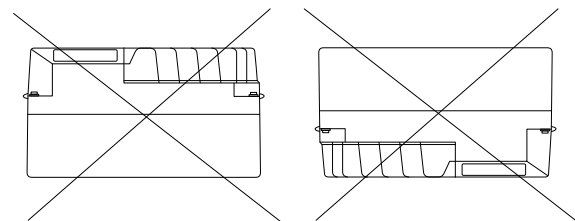
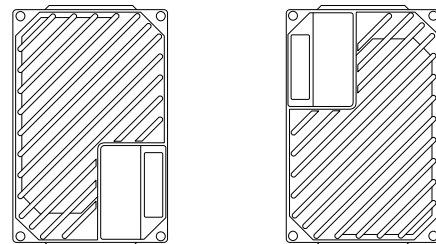
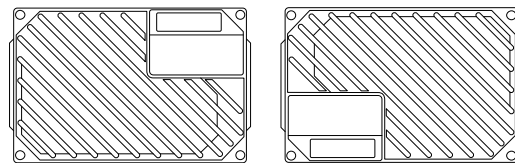

Illustration 2.7 Permitted Mounting Positions - Standard Applications

2.3.4.1 Hygienic Installation

The FCD 302 is designed according to the EHEDG guidelines, suitable for installation in environments with high focus on ease of cleaning.

Mount the FCD 302 vertically on a wall or machine frame, to ensure liquids drain off the enclosure. Orient the unit so the cable glands are located at the base.

Use cable glands designed to meet hygienic application requirements, for example Rittal HD 2410.110/120/130. Hygienic-purpose cable glands ensure optimal ease of cleaning in the installation.

NOTICE

Only frequency converters configured as hygienic enclosure designation, FCD 302 P XXX T4 W69, have the EHEDG certification.

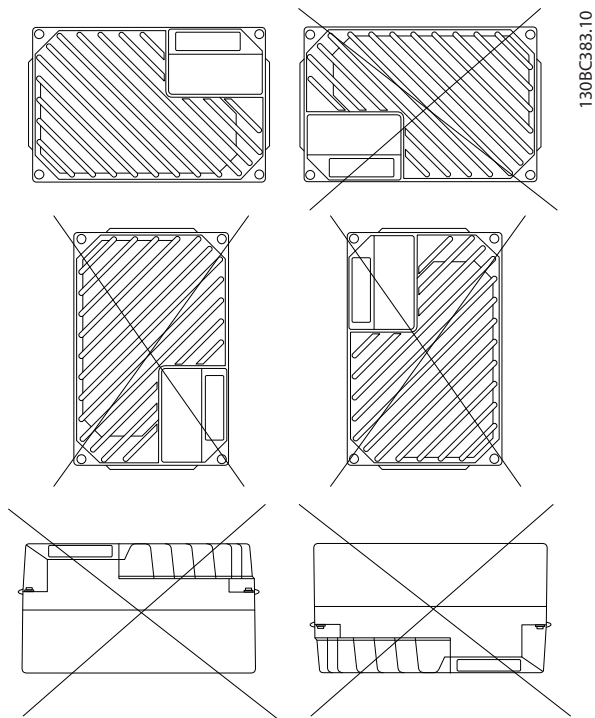

Illustration 2.8 Permitted Mounting Positions - Hygienic Applications

2.3.4.2 Cleaning

The enclosure (IP66/NEMA type 4x indoor) provides protection against dirt and water ingress. The enclosure is suitable for cleaning methods and solvents used in food and beverage plants. Use the solvent concentration recommended by the manufacturer. Avoid high pressure hot water cleaning at close proximity or of long duration, because this method of cleaning can damage gaskets and labels.

2.3.5 Tightening Torques

To compress the gasket between the two parts,

- Tighten the four connection screws to torque 2.8–3.0 Nm (24.8–26.6 in-lb).
- Tighten these screws in diagonally opposite order.
- Tighten the two earthing spears to torque 3.0 Nm (26.6 in-lb).

2.4 Electrical Installation

The frequency converter must be wired for operation in the following manner:

- Wire the motor to the frequency converter output terminals.
- Connect control and serial communication wiring.
- Wire the AC mains to the frequency converter input terminals.
- After power has been applied, input and motor power must be checked, and control terminals programmed for intended functions.

This section provides detailed descriptions of the requirements and procedures to accomplish these tasks. *Illustration 2.9* shows a basic electrical connection.

2

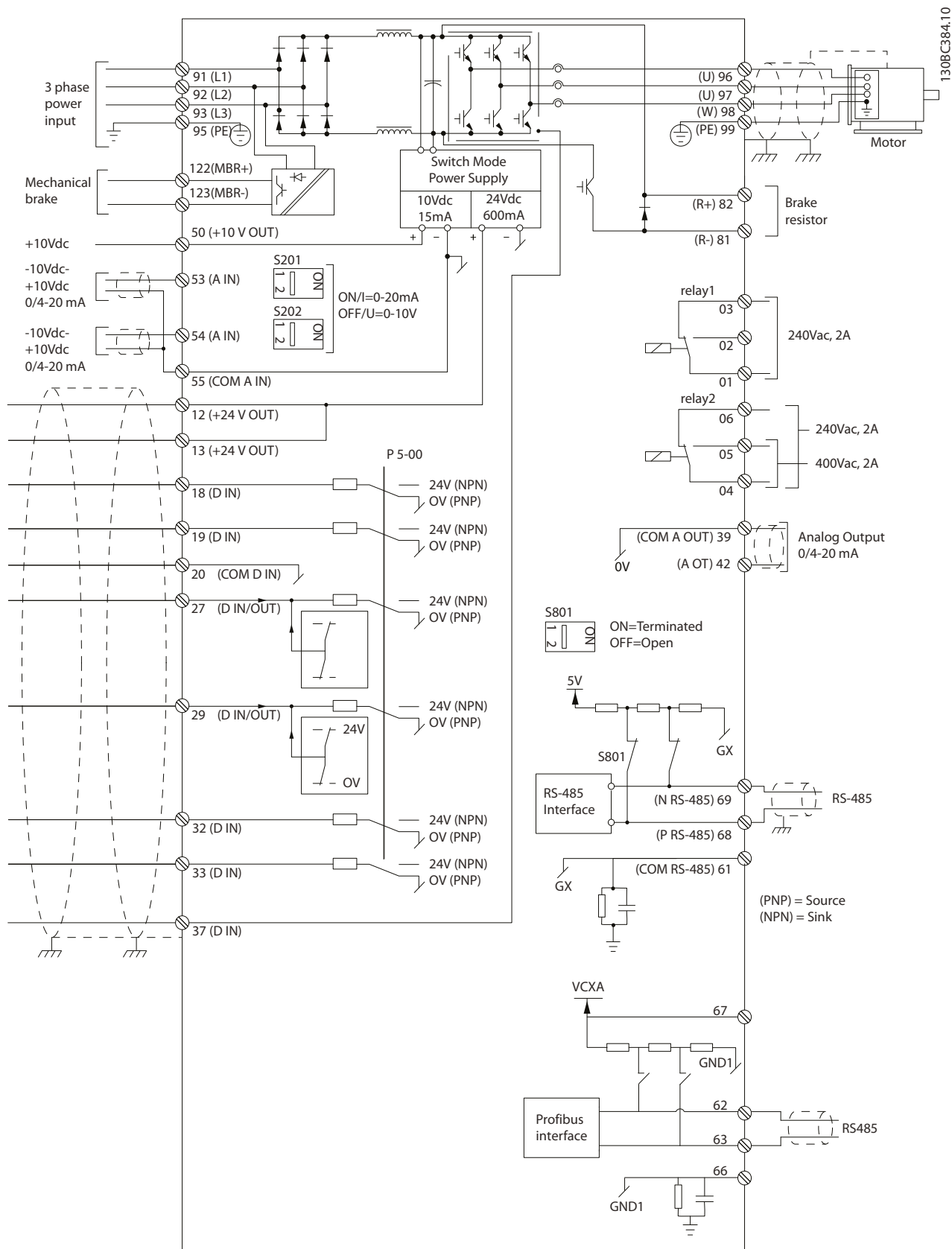
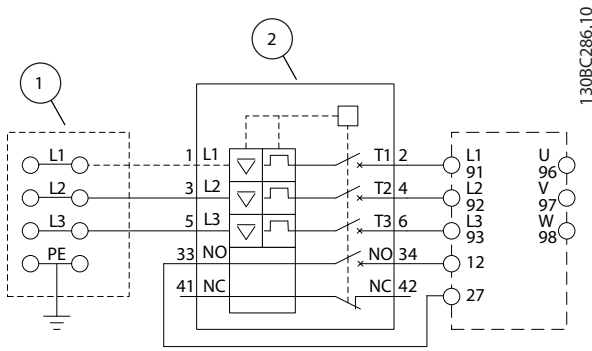
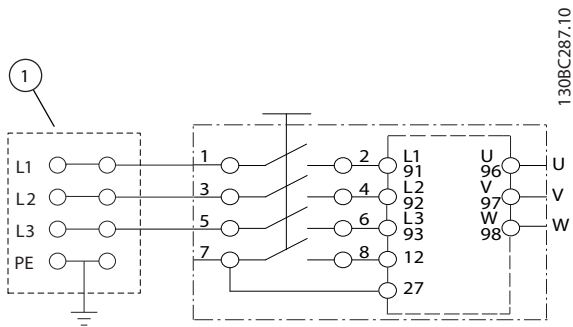

Illustration 2.9 Electrical Installation



1	Looping terminals
2	Circuit breaker

Illustration 2.10 Large Unit only: Circuit Breaker and Mains Disconnect



1	Looping terminals
---	-------------------

Illustration 2.11 Large Unit only: Service Switch at Mains with Looping Terminals

2.4.1 Requirements

⚠ WARNING

EQUIPMENT HAZARD

Rotating shafts and electrical equipment can be hazardous. All electrical work must conform to national and local electrical codes. Installation, start-up, and maintenance to be performed only by trained and qualified personnel. Failure to follow these guidelines could result in death or serious injury.

For your safety, comply with the following requirements:

- Electronic controls equipment is connected to hazardous mains voltage. Take extreme precautions against electrical hazards when applying power to the unit.
- Wear safety glasses whenever working on electric control or rotating equipment.

- Run motor cables from multiple frequency converters separately. Induced voltage from output motor cables run together can charge equipment capacitors even with the equipment turned off and locked out.

Overload and equipment protection

- An electronically activated function within the frequency converter provides overload protection for the motor. Set *parameter 1-90 Motor Thermal Protection* to warning or trip as required. Refer to the *VLT® Decentral Drive FCD 302 Programming Guide MG04GXYY* for further information. *Parameter 1-90 Motor Thermal Protection* measures motor current and is internally set based on the value in *parameter 1-24 Motor Current*. A 1.2 x FLA (full load amps) service factor is built in and maintained. Should the motor current increase above that value, the overload calculates the level of increase to activate timing for the trip (controller output stop) function. The higher the current draw, the quicker the trip response. The overload provides Class 20 motor protection. See *chapter 7 Troubleshooting* for details on the trip function.
- Because the motor wiring carries high frequency current, it is important that wiring for mains input power, motor power, and control are run separately. Use separated shielded wire or metallic conduit. Failure to isolate power, motor, and control wiring could result in less than optimum equipment performance.
- When using cable trays, place sensitive cables such as telephone or data cables in a separate cable tray to the motor cable. If signal cables run across power cables, these cables must cross at an angle of 90°.

Wire type and ratings

- All wiring must comply with local and national regulations regarding cross-section and ambient temperature requirements.
- The screen must have low RF impedance, which is achieved by a braided screen of copper, aluminium or iron.
- Danfoss recommends that all power connections are made with a minimum 75 °C (167 °F) rated copper wire.
- See *chapter 8.1 Electrical Data and Wire Sizes* for recommended wire sizes.

Cable glands

It must be assured that appropriate cable glands needed for the environment are chosen and carefully mounted.

2**⚠ WARNING****HIGH VOLTAGE**

Unplugging the electronic part may cause death, or serious injury and damage to the frequency converter, the motor, and the equipment operated by the motor.

- Do not plug/unplug the electronic part with mains voltage switched on.
- Switch off mains voltage in the intended safe way.

2.4.2 Location of Terminals

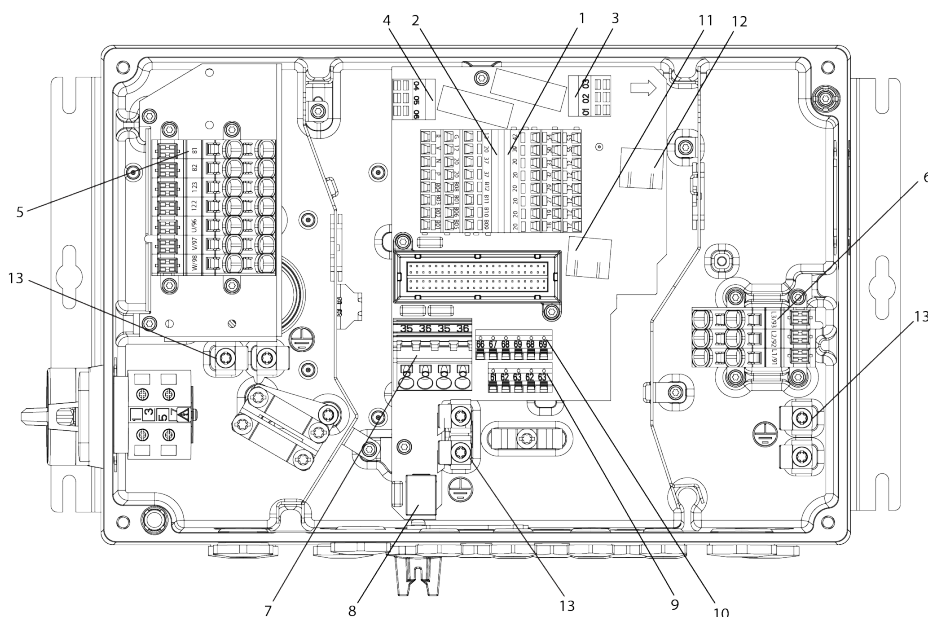

130BC385.10

Illustration 2.12 Location of Terminals (Small Unit)

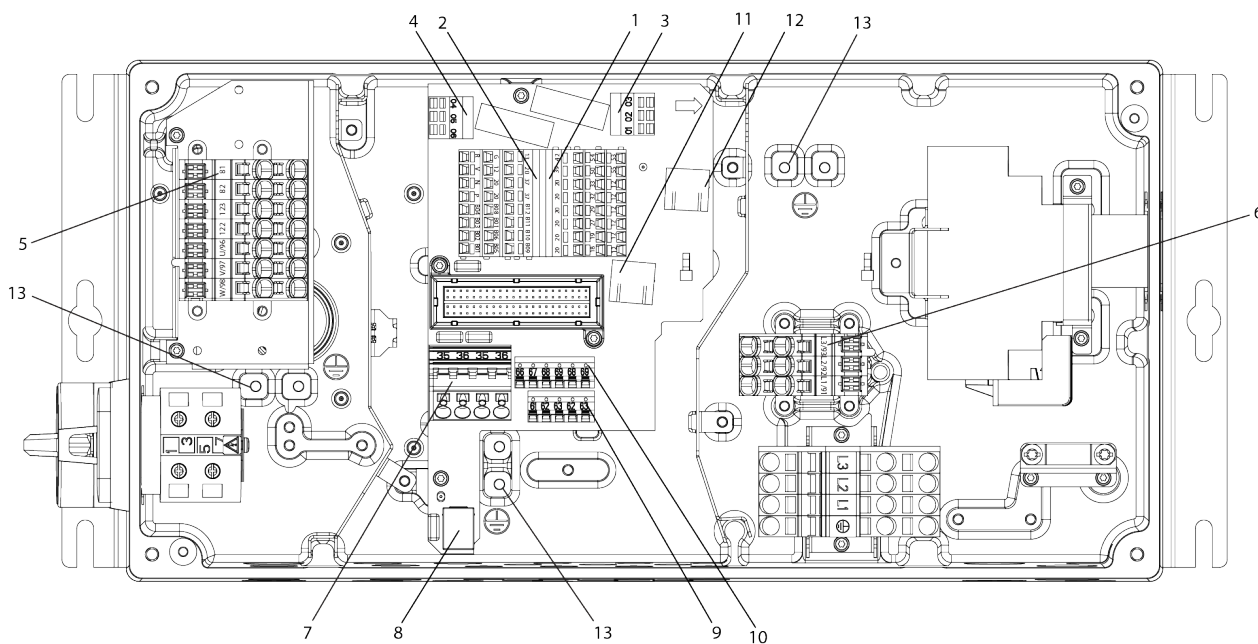

130BC386.10

1	Digital and analog inputs/outputs	8	USB port
2	Safe stop, LCP connection, B-option	9	Standard bus/RS485
3	Relay 1	10	Profibus
4	Relay 2	11	Ethernet port
5	Motor, mechanical brake, brake resistor	12	Ethernet port
6	Mains	13	Protective Earth (PE)
7	24 V DC back-up input		

Illustration 2.13 Location of Terminals (Large Unit)

For both small and large unit, the service switch is optional. The switch is shown mounted on the motor side. Alternatively, the switch can be located on the mains side, or omitted.

For the large unit, the circuit breaker is optional. The large unit can be configured with either service switch or circuit breaker, not both. The illustration shown is not configurable in practice, but is displayed to show the respective positions of components only.

2.4.3 Terminal Types

Motor, control, and mains terminals are spring loaded (CAGE-CLAMP) type.

1. Open the contact by inserting a small screwdriver into the slot above the contact, as shown in *Illustration 2.14*.
2. Insert the stripped wire into the contact.
3. Remove the screwdriver to fasten the wire into the contact.
4. Ensure that the contact is firmly established and not loose. Loose wiring can result in equipment faults or injury.

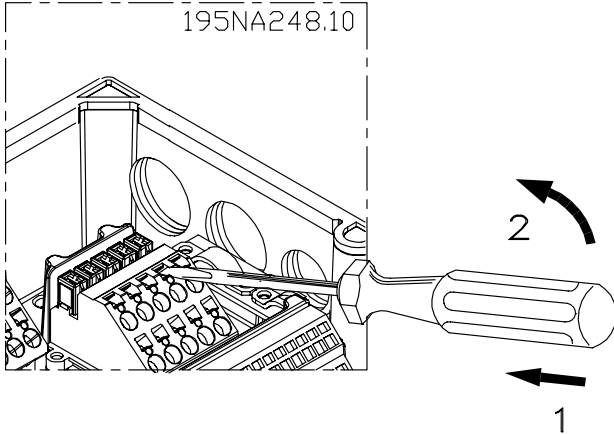

Illustration 2.14 Opening the Terminals

2.4.4 Motor Connection

WARNING INDUCED VOLTAGE

Run output motor cables from multiple frequency converters separately. Induced voltage from output motor cables run together can charge equipment capacitors even with the equipment turned off and locked out. Failure to run output motor cables separately could result in death or serious injury.

CAUTION

WIRING ISOLATION

Run input power, motor wiring, and control wiring in three separate metallic conduits. Alternatively, use separated shielded motor and control cables for high frequency noise isolation. Failure to isolate power, motor and control wiring can result in sub-optimal performance of the frequency converter and associated equipment.

CAUTION

MOTOR PROTECTION

Protection against motor overload is not included in the factory setting. If this function is desired, set *parameter 1-90 Motor Thermal Protection* to trip or warning. Refer to the *VLT® Decentral Drive FCD 302 Programming Guide MG04GXYY* for further information.

- Connect the motor to terminals 96, 97, 98.
- Connect earth to PE-terminal.
- Make sure that the screen of the motor cable is properly earthed at both ends (motor and frequency converter).
- For correct dimensioning of cable cross-section, see *chapter 8.1.1 Overview*.

No.			
96	97	98	Motor voltage 0-100% of mains voltage
U	V	W	3 wires out of motor
U1	V1	W1	6 wires out of motor
W2	U2	V2	
U1	V1	W1	6 wires out of motor, Star connected Connect U2, V2, W2 separately (optional terminal block)
PE			Earth connection

Table 2.1 Motor Terminals

NOTICE

Do not install power factor correction capacitors between the frequency converter and the motor. Do not wire a starting or pole-changing device between the frequency converter and the motor.

Parallel connection of motors

The frequency converter can control several parallel-connected motors. The total current consumption of the motors must not exceed the rated output current $I_{M,N}$ for the frequency converter.

NOTICE

- Installations with cables connected in a common joint as in *Illustration 2.15*, is only recommended for short cable lengths (maximum 10 m (32.8 ft)).
- When motors are connected in parallel, *parameter 1-29 Automatic Motor Adaptation (AMA)* cannot be used.

CAUTION

INSUFFICIENT MOTOR PROTECTION

The electronic thermal relay (ETR) of the frequency converter cannot be used as motor protection for the individual motor in systems with parallel-connected motors. Provide further motor protection by thermistors in each motor or individual thermal relays. Circuit breakers are not suitable as protection.

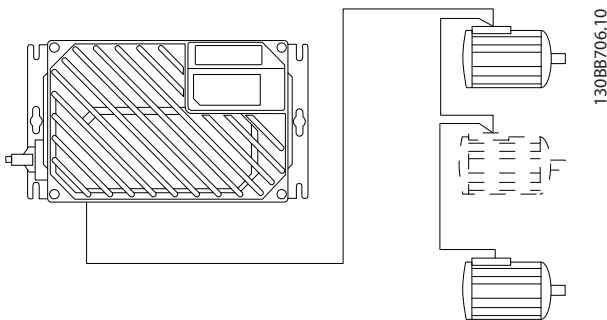

Illustration 2.15 Parallel Connection of Motors

Problems can arise at start-up and at low RPM values, when motor sizes differ widely. Motors of low rated motor power have a relatively high ohmic resistance in the stator. This high resistance calls for a higher voltage at start and at low RPM values. To resolve such a problem:

- reduce the load during startup, on the motor of lowest rated motor power
- configure parallel connections only between motors of comparable rated motor power

2.4.5 Control Wiring

WARNING

UNINTENDED START

When frequency converter is connected to AC mains input power, the motor can start at any time. The frequency converter, motor, and any driven equipment must be in operational readiness. Failure to be in operational readiness when the frequency converter is connected to AC mains could result in death, serious injury, equipment, or property damage.

- It is recommended that control wiring is rated for 600 V.
- Isolate control wiring from high-power components in the frequency converter.
- If the frequency converter is connected to a thermistor, for PELV isolation, ensure control wiring is reinforced/double insulated.
- See *chapter 8.2 General Specifications* for control terminal wiring sizes and maximum loads.

Terminal No.	Function
01, 02, 03	Relay 1 output. Useable for AC or DC voltage and resistive or inductive loads.
04, 05, 06	Relay 2 output. Useable for AC or DC voltage and resistive or inductive loads.
12, 13	24 V DC digital supply voltage. Useable for digital inputs and external transducers. To use the 24 V DC for digital input common, programme <i>parameter 5-00 Digital I/O Mode</i> for PNP operation.
18, 19, 32, 33	Digital inputs. Selectable for NPN or PNP function in <i>parameter 5-00 Digital I/O Mode</i> . Default is PNP.
27, 29	Digital inputs or outputs. Programmable for either <i>parameter 5-01 Terminal 27 Mode</i> for terminal 27 and <i>parameter 5-02 Terminal 29 Mode</i> for 29 selects input/output function. Default setting is input.
35	Common (-) for external 24 V control back up supply. Optional.
36	External + 24 V control back up supply. Optional.
37	Safe Stop. See Safe Stop installation for details.
20	Common for digital inputs. To use for digital input common, programme <i>parameter 5-00 Digital I/O Mode</i> for NPN operation.
39	Common for analog output.
42	Analog output. Programmable for various functions in parameter group 6-5*. The analog signal is 0-20 mA or 4-20 mA at a maximum of 500 Ω.
50	10 V DC analog supply voltage. 15 mA maximum commonly used for a potentiometer or thermistor.

Terminal No.	Function
53, 54	Analog input. Selectable for voltage (0 to ±10 V) or current (0- or 4 to ±20 mA). Closed is for current and open is for voltage. Switches are located on the frequency converter control card. See <i>chapter 2.4.13 DIP Switches</i>
55	Common for analog inputs.
61	Common for serial communication (RS485 interface). See <i>chapter 2.4.13 DIP Switches</i>
68 (+), 69 (-)	RS485 interface. When the frequency converter is connected to an RS485 serial communication bus, a switch on the control card is provided for termination resistance. Set the switch to ON for termination and OFF for no termination.
62	RxD/TxD -P (red cable) for Profibus. See dedicated literature (MCA 101) for details.
63	RxD/TxD -N (green cable) for Profibus.
66	0 V for Profibus.
67	+5 V for Profibus.
B01-B12	B-option. See dedicated literature for details.
G, R, V, N, P	Connection of LCP.

Table 2.2 Function of Terminals

2.4.6 AC Mains Input Connection

⚠WARNING

IT MAINS OR DELTA-GROUNDED MAINS

Do not connect 400 V frequency converters with RFI-filters to mains supplies with a voltage between phase and earth of more than 440 V.

For IT mains and delta-grounded mains, mains voltage may exceed 440 V between phase and earth.

- Size wiring based upon the input current of the frequency converter. See the maximum wire size in the Input Current and Wire tables in *chapter 8 Specifications*.
- Comply with local and national electrical codes for cable sizes.
- Connect 3-phase AC input power wiring to terminals L1, L2, and L3.
- Depending on the configuration of the equipment, connect the input power to the mains input terminals or the input disconnect.
- Ground the cable in accordance with grounding instructions provided in *General Earth (Ground) Requirements*.
- All frequency converters can be used with an isolated input source as well as with ground reference power lines. When supplied from an isolated mains source (IT mains or floating delta) or TT/TN-S mains with a grounded leg (grounded delta), set *parameter 14-50 RFI Filter* to OFF. When

set to OFF, the internal RFI filter capacitors between the chassis and the intermediate circuit are isolated, to avoid damage to the intermediate circuit and to reduce earth capacity currents in accordance with IEC 61800-3.

No.			
91	92	93	Mains voltage 3x380-480 V
L1	L2	L3	
PE			Earth connection

Table 2.3 AC Mains Input Terminals

2.4.7 Motor and Mains Connection with Service Switch

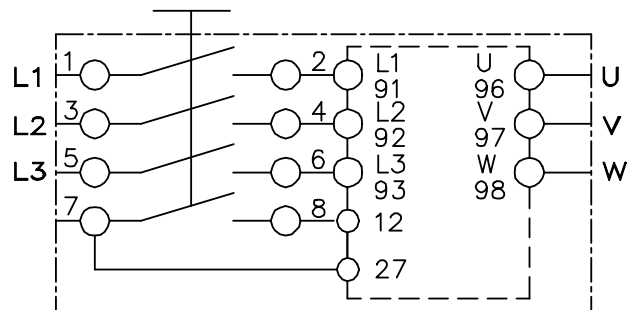
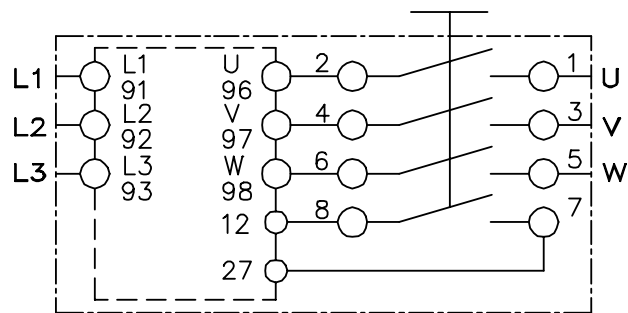

195NA288.10

Illustration 2.16

2.4.8 Brake Resistor

No.	81 (optional function)	82 (optional function)	Brake resistor terminals
	R-	R+	

Table 2.4 Brake Resistor Terminals

- The connection cable to the brake resistor must be screened/armoured. Connect the screen to the metal cabinet of the frequency converter and to the metal cabinet of the brake resistor with cable clamps.
- Dimension the cross-section of the brake cable to match the brake torque.

2.4.9 Mechanical Brake

No.	122 (optional function)	123 (optional function)	
	MBR+	MBR-	Mechanical brake UDC = 0.45 x RMS mains voltage max. current = 0.8 A

Table 2.5 Mechanical Brake Terminals

In hoisting/lowering applications, control of electro-mechanical brake is required:

- The brake is controlled using the special mechanical brake control/supply terminals 122 and 123.
- Select [32] *Mechanical brake control* in parameter group 5-4*, [1] *Array*, Relay 2 for applications with an electro-mechanical brake.
- The brake is released when the motor current exceeds the preset value in parameter 2-20 *Release Brake Current*.
- The brake is engaged when the output frequency is less than the frequency set in parameter 2-21 *Activate Brake Speed [RPM]* or parameter 2-22 *Activate Brake Speed [Hz]*. The brake engages only when the frequency converter performs a stop command.

When the frequency converter enters alarm mode or is exposed to an over-voltage situation, the mechanical brake immediately cuts in. For more detailed information, refer to the *VLT® Decentral Drive FCD 302 Programming Guide*.

NOTICE

When the Mechanical Brake Control/Supply terminals 122 and 123 are set through parameter group 5-4*, [1] *Array*, Relay 2, only one relay output (Relay 1) is available for free programming.

2.4.10 Connection of Sensors/Actuators on M12 Sockets

Pin	Wire colour	Terminal	Function
1	Brown	12	+24 V
3	Blue	20	0 V
4	Black	18, 19, 32, 33	Digital input

Table 2.6 4xM12 Connection Input

Pin	Wire colour	Terminal	Function
1	Brown	Reserved*	Reserved
3	Blue	20	0 V
4	Black	02, 05	N.O. (24 V)

Table 2.7 2xM12 Connection Output

* When reserved wires for option are used. If not utilised, they can be cut off.

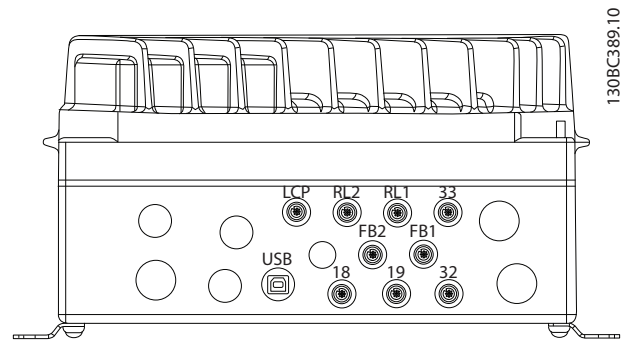

Illustration 2.17 Connectors for Sensors/Actuators

2.4.11 Earth (Grounding) Requirements

WARNING

GROUNDING HAZARD

For operator safety, it is important to ground frequency converter properly in accordance with national and local electrical codes as well as instructions contained within this manual. Ground currents are higher than 3.5 mA. Failure to ground frequency converter properly could result in death or serious injury.

NOTICE

It is the responsibility of the user or certified electrical installer to ensure correct grounding (earthing) of the equipment in accordance with national and local electrical codes and standards.

- Proper protective grounding for equipment with ground currents higher than 3.5 mA must be established, see *Leakage Current (3.5 mA)* following.
- A dedicated ground wire is required for input power and motor.
- Use the clamps provided with on the equipment for proper ground connections.
- Use of high-strand wire to reduce electrical noise is recommended.

2

CAUTION**PE CONNECTION**

The metal pins in the corners of the electronic part and the holes on the corner of the installation box are essential for the protective earth connection. Make sure that they are not loosened, removed, or violated in any way. Tightening torque requirement is 3 Nm. See *Illustration 2.18*.

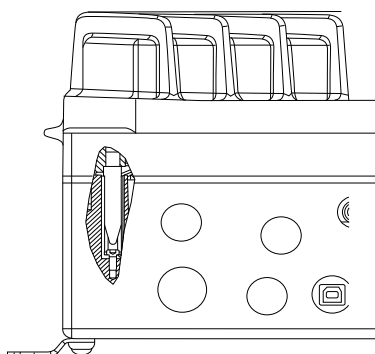

130BC391.10

Illustration 2.18 PE Connection between the Installation Box and the Electronic Part

NOTICE

The external grounding terminal is available as an accessory (part no: 130B5833).

Grounding shielded cable

Earthing (grounding) clamps are provided for motor and control wiring (see *Illustration 2.19*).

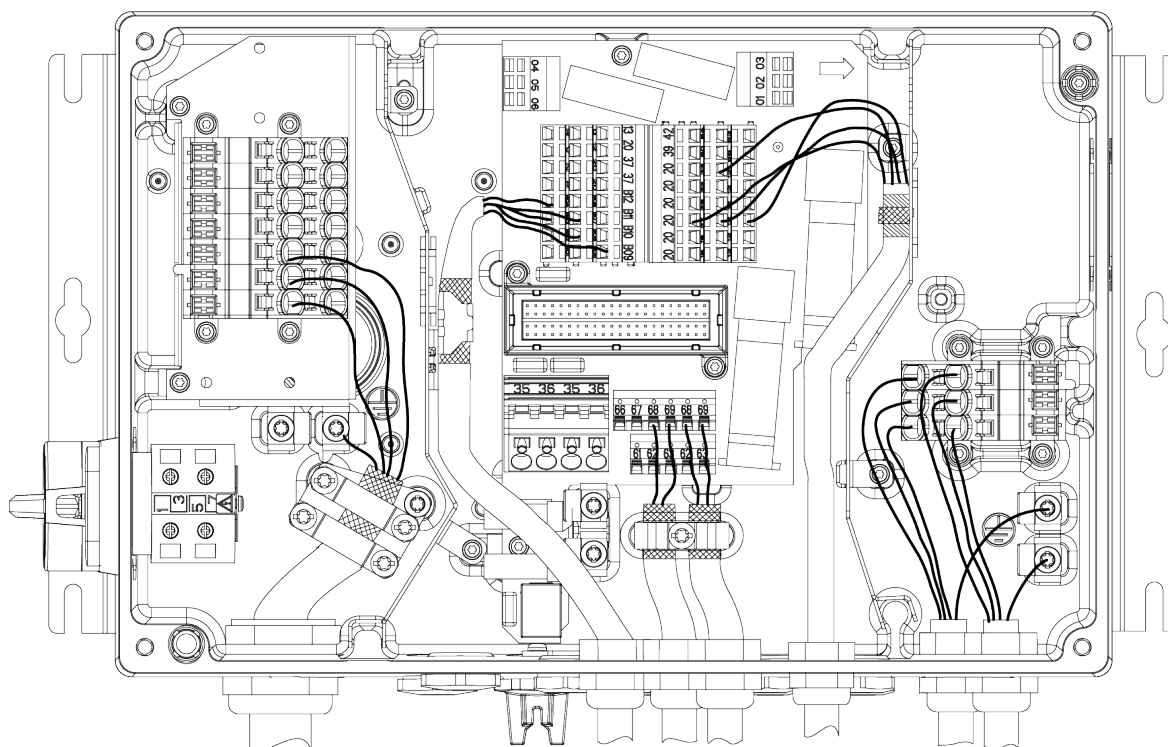

130BC403.10

Illustration 2.19 Earthing (Grounding) Clamp for Motor and Control Wiring (Small Unit)

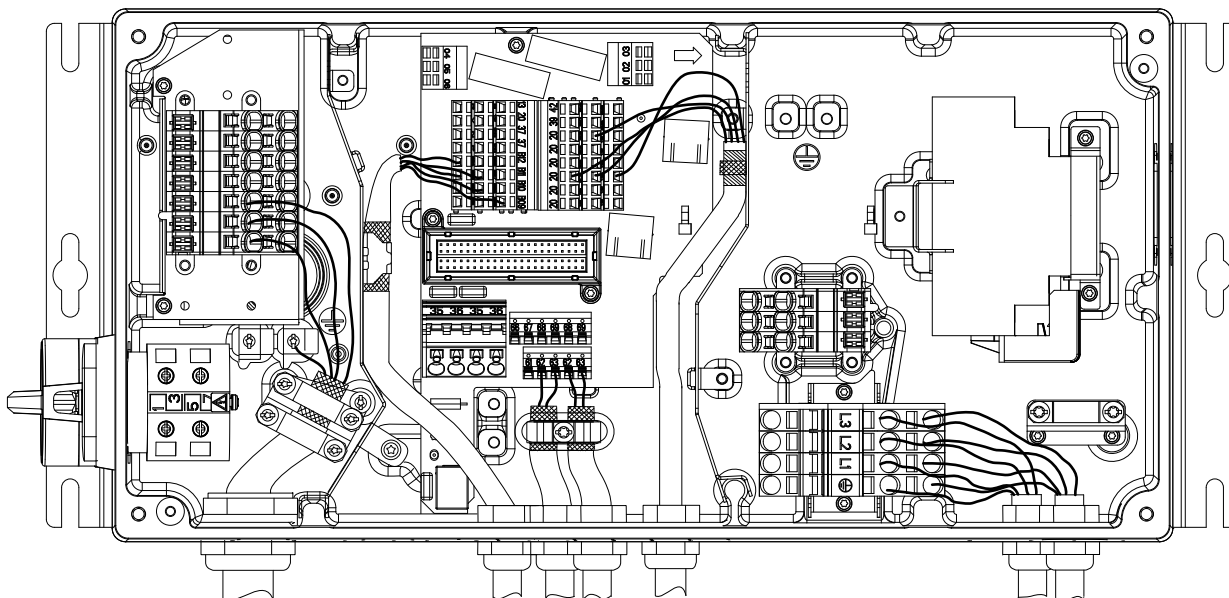

130BC390.10

Illustration 2.20 Earthing (Grounding) Clamp for Motor and Control Wiring (Large Unit)

1. Use a wire stripper to remove the insulation for proper grounding.
2. Secure the grounding clamp to the stripped portion of the wire with the screws provided.
3. Secure the grounding wire to the grounding clamp provided.

Leakage current (3.5 mA)

NOTICE

Follow national and local codes regarding protective earthing of equipment with a leakage current > 3.5 mA.

The frequency converter technology implies high frequency switching at high power. This generates a leakage current in the earth connection. RFI filtering and screened motor cables contribute to this phenomenon. According to EN/IEC61800-5-1 (Power Drive System Product Standard) which implies special means if the leakage current exceeds 3.5 mA, earth grounding must be reinforced in one of the following ways:

- Earth ground wire, 10 mm² (optional accessory required for mounting, part no. 130B5974).
- Two separate earth ground wires both complying with the dimensioning rules.

RCD use

A fault current in the frequency converter or at the output power terminals can contain a DC component, and charging of the filter capacitors can cause a transient earth current. Where Residual Current Devices (RCDs), also known as Earth Leakage Circuit Breakers (ELCBs), are used, the following must be taken into account:

- Use RCDs of type B only
- Use RCDs with an inrush delay
- Use RCDs of 300 mA, if possible

2.4.12 Grounding of Screened Control Cables

Correct screening

The preferred method usually is to secure control and cables with screening clamps provided at both ends. This ensures the best possible high frequency cable contact. If the ground potential between the units connected by a control cable is different, electric noise may occur and potentially disturb the entire system. Mitigate this problem by fitting an equalizing conductor next to the control cable. Use an equalizing conductor with a minimum cross-section of 16 mm².

The impedance of the equalizing conductor should typically be maximum 10% of the impedance of the control cable screen. See also the requirements regarding electrical safety and grounding in *chapter 2.4.11 Earth (Grounding) Requirements*

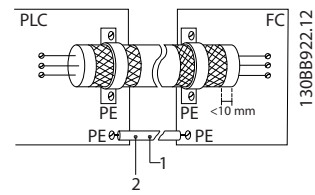

Illustration 2.21 Correct Shielding with Equalizing Cable

1	Min. 16 mm ² (4 AWG)
2	Equalizing conductor

50/60 Hz ground loops

With long control cables, ground loops may occur. To eliminate ground loops, connect one end of the screen-to-ground with a 100 nF capacitor (keeping leads short).

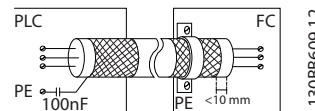

Illustration 2.22 Screen-to-ground Connected to a 100 nF Capacitor

Avoid EMC noise on serial communication

This terminal is connected to ground via an internal RC link. To reduce interference between conductors, use twisted-pair cables.

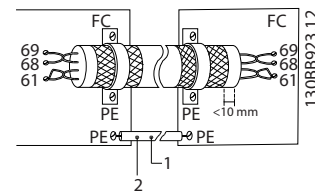

Illustration 2.23 Recommended Method for Avoiding EMC Noise

1	Min. 16 mm ² (4 AWG)
2	Equalizing conductor

Alternatively, the connection to terminal 61 can be omitted:

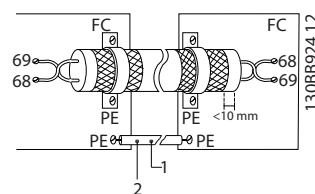
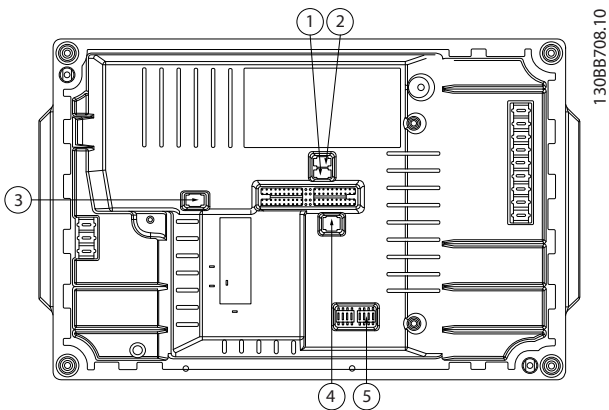

Illustration 2.24 Screening without Using Terminal 61

1	Min. 16 mm ² (4 AWG)
2	Equalizing conductor

2.4.13 DIP Switches

- Analog input terminals 53 and 54 can select for either voltage (0-10 V) or current (0-20 mA) input signals.
- Set switches S201 (terminal 53) and S202 (terminal 54) to select the signal type. ON is for current, OFF for voltage.
- Terminal 53 default is for a speed reference in open loop.
- Terminal 54 default is for a feedback signal in closed loop.



1	S201 - terminal 53
2	S202 - terminal 54
3	S801 - standard bus termination
4	Profibus termination
5	Fieldbus address

Illustration 2.25 Location of DIP Switches

NOTICE

Switches 4 and 5 are only valid for units fitted with fieldbus options.

2.4.14 Serial Communication

Connect RS485 serial communication wiring to terminals (+)68 and (-)69.

- Switch S801 (BUS TER.) can be used to enable termination on the RS485 port (terminals 68 and 69). See *Illustration 2.25*.
- Shielded serial communication cable is recommended
- See *chapter 2.4.11 Earth (Grounding) Requirements* for proper grounding

- Two communication protocols are internal to the frequency converter
 - Danfoss FC
 - Modbus RTU
- For basic serial communication setup, select the following
 - Protocol type in *parameter 8-30 Protocol*
 - Frequency converter address in *parameter 8-31 Address*
 - Baud rate in *parameter 8-32 Baud Rate*
- Functions can be programmed remotely using the protocol software and RS485 connection or in *parameter group 8-** Communications and Options*
- Selecting a specific communication protocol changes various default parameter settings to match that specifications of the protocol along with making additional protocol-specific parameters available
- Control card options are available to provide additional communication protocols. See the option-card documentation for installation and operation instructions
 - PROFIBUS
 - Ethernet IP
 - PROFINET

2.4.15 Connection to PC

To control the frequency converter from a PC, install the MCT 10 Set-up Software.

The PC is connected via a standard (host/device) USB cable, or via the RS485 interface.

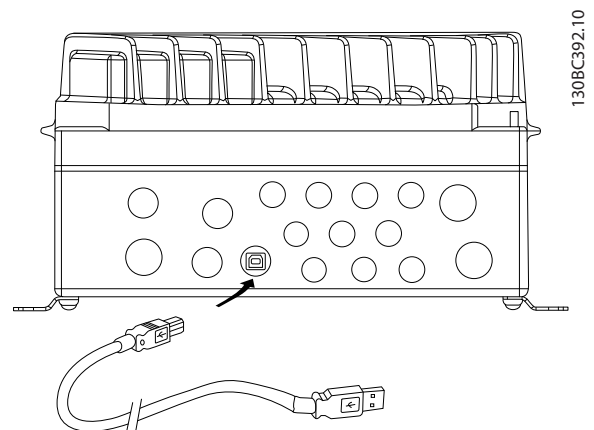

Illustration 2.26 Electronic Part

2

CAUTION

The USB connection is galvanically isolated from the supply voltage (PELV) and other high-voltage terminals. The USB connection is not galvanically isolated from protection earth. Use only isolated laptop/PC as connection to the USB connector on frequency converter or an isolated USB cable/converter.

2.4.16 Safe Stop

The VLT® Decentral Drive FCD 302 provides safe stop functionality via control terminal 37. Safe stop disables the control voltage of the power semiconductors of the frequency controller output stage. This in turn prevents generating the voltage required to rotate the motor. When the Safe Stop (T37) is activated, the frequency converter issues an alarm, trips the unit, and coasts the motor to a stop. Manual restart is required. The safe stop function can be used for stopping the frequency converter in emergency stop situations. In the normal operating mode when safe stop is not required, use the regular stop function of the frequency converter instead.

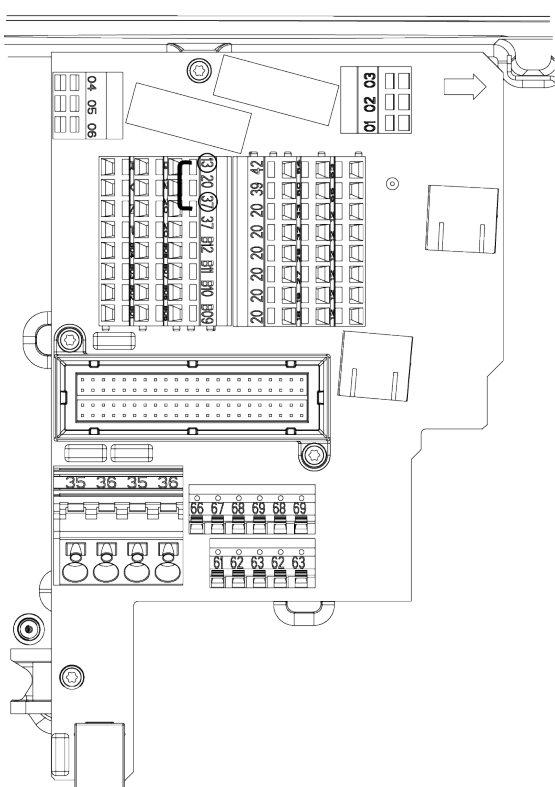

130BC393.10

Illustration 2.27 Jumper between Terminal 13 and 37

3 Start Up and Functional Testing

3.1 Pre-start

3.1.1 Safety Inspection

⚠ WARNING

HIGH VOLTAGE

If input and output connections have been connected improperly, there is risk for high voltage on these terminals. For initial startup, make no assumptions about power components. Follow pre-start procedures. Failure to follow pre-start procedures could result in personal injury or damage to equipment.

1. Input power to the unit must be OFF and locked out.
2. Verify that there is no voltage on input terminals L1 (91), L2 (92), and L3 (93), phase-to-phase and phase-to ground.
3. Verify that there is no voltage on output terminals 96 (U), 97(V), and 98 (W), phase-to-phase and phase-to ground.
4. Confirm continuity of the motor by measuring ohm values on U-V (96-97), V-W (97-98), and W-U (98-96).
5. Inspect the frequency converter for loose connections on terminals.
6. Close the box, mounting the electronic part onto the installation box.
7. Check for proper grounding of the frequency converter as well as the motor.
8. Record the following motor-nameplate data: power, voltage, frequency, full load current, and nominal speed. These values are required to program motor nameplate data later on.
9. Confirm that the supply voltage matches voltage of frequency converter and motor.

3.1.2 Start Up Check List

CAUTION

Before applying power to the unit, inspect the entire installation as detailed in *Table 3.1*.

3

Inspect for	Description	<input checked="" type="checkbox"/>
Auxiliary equipment	<ul style="list-style-type: none"> Look for auxiliary equipment, switches, disconnects, or input fuses/circuit breakers located on input power side of frequency converter, or output side to motor. Examine their operational readiness and ensure that they are ready in all respects for operation at full speed. Check function and installation of any sensors used for feedback to frequency converter Remove power factor correction caps on motor(s), if present 	
Cable routing	Ensure that input power, motor wiring and control wiring are separated or in three separate metallic conduits for high frequency noise isolation.	
Control wiring	<ul style="list-style-type: none"> Check for broken or damaged wires and connections Check the voltage source of the signals, if necessary The use of shielded cable or twisted pair is recommended. Ensure that the shield is terminated correctly at both ends. 	
EMC considerations	Check for proper installation regarding electromagnetic compatibility.	
Environmental considerations	See equipment label for the maximum ambient operating temperature limits. Temperature is not to exceed 40°C (104°F). Humidity levels must be 5-95% non-condensing.	
Cooling clearance	Units require top and bottom clearance adequate to ensure proper air flow for cooling.	
Fusing and circuit breakers	Check that all fuses are inserted firmly and in operational condition and that all circuit breakers are in the open position. Check for proper fusing or circuit breakers.	
Input and output power wiring	<ul style="list-style-type: none"> Check for loose connections Check for proper fusing or circuit breakers 	
Switches	Ensure that all switch and disconnect settings are in the proper position.	
Grounding	The equipment requires a dedicated ground wire from its chassis to the plant ground. Check for good ground connections that are tight and free of oxidation.	
Installation box and electronics part	Ensure the installation box and the electronics part is properly closed. Check that all four fastening screws are tightened with the right torque.	
Cable glands and blind plugs	Ensure the cable glands and blind plugs are properly tightened, to guarantee the right enclosure protection degree is achieved. Liquids and/or excessive dust ingress in the frequency converter can cause sub-optimal performance or damage.	
Vibration	Ensure the equipment is not exposed to a high level of vibration. Mount the panel solidly or use shock mounts as necessary.	

Table 3.1 Start Up Check List

3.2 Applying Power to the Frequency Converter

⚠ WARNING

HIGH VOLTAGE

Frequency converters contain high voltage when connected to AC mains input power. Only qualified personnel must perform installation, start-up and maintenance. Failure to perform installation, start-up and maintenance by qualified personnel could result in death or serious injury.

1. Perform pre-start up procedure described in *chapter 3.1 Pre-start*.
2. Confirm input line voltage is balanced within 3%. If not, correct input voltage imbalance before proceeding. Repeat procedure after voltage correction.
3. Ensure optional equipment wiring, if present, matches installation application.
4. Ensure that all operator devices are in OFF position.

⚠ WARNING

UNINTENDED START

When frequency converter is connected to AC mains input power, the motor may start at any time. The frequency converter, motor, and any driven equipment must be in operational readiness. Failure to be in operational readiness when the frequency converter is connected to AC mains could result in death, serious injury, equipment, or property damage.

5. Apply power to the unit. DO NOT start the frequency converter at this time. For units with a disconnect switch on the mains side, turn to the ON position to apply power to the frequency converter.

3.3 Quick Setup

Frequency converters require basic operational programming before running for best performance. Basic operational programming requires entering motor-nameplate data for the motor being operated and the minimum and maximum motor speeds. Enter this data in accordance with the following procedure. See *chapter 4 User Interface*, for detailed instructions on entering data through the LCP. Enter this data with power ON, but before operating the frequency converter.

1. Press [Quick Menu] on the LCP.
2. Use the navigation keys to scroll to parameter group Q2 *Quick Setup* and press [OK].

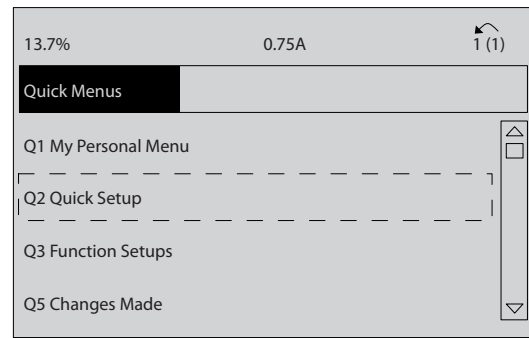

Illustration 3.1 Quick Setup Menu

3. Select language and press [OK]. Then enter the motor data in *parameter 1-20 Motor Power [kW]*/*parameter 1-21 Motor Power [HP]* through *parameter 1-25 Motor Nominal Speed*. The information can be found on the motor nameplate. The entire quick menu is shown in *International/North American Default Parameter Settings*

Parameter 1-20 Motor Power [kW]

Parameter 1-21 Motor Power [HP]

Parameter 1-22 Motor Voltage

Parameter 1-23 Motor Frequency

Parameter 1-24 Motor Current

Parameter 1-25 Motor Nominal Speed

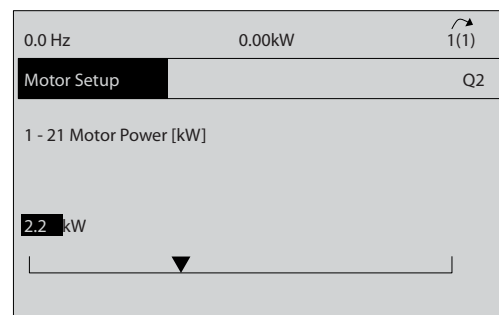

Illustration 3.2 Motor Setup Menu

4. Continue set-up of Quick Menu parameters:
 - Parameter 5-12 Terminal 27 Digital Input*. If terminal default is *Coast inverse* it is possible to change this setting to *No function*.
 - Parameter 1-29 Automatic Motor Adaptation (AMA)*. Set desired AMA function. Enable complete AMA is

recommended. See detailed *chapter 3.4 Automatic Motor Adaptation*.

Parameter 3-02 Minimum Reference. Set the minimum speed of the motor shaft.

Parameter 3-03 Maximum Reference. Set the maximum speed of the motor shaft.

Parameter 3-41 Ramp 1 Ramp Up Time. Set the ramping up time regarding synchronous motor speed, ns

Parameter 3-42 Ramp 1 Ramp Down Time. Set the ramping down time regarding synchronous motor speed, ns

Parameter 3-13 Reference Site. Set the site from where the reference must work

See *Quick Menu Parameters* for further details.

3.4 Automatic Motor Adaptation

Automatic motor adaptation (AMA) is a test procedure which measures the electrical characteristics of the motor. The AMA procedure optimizes compatibility between the frequency converter and the motor. The frequency converter builds a mathematical model of the motor for regulating output motor current. The procedure also tests the input phase balance of electrical power and compares the motor characteristics with the data entered in parameters 1-20 to 1-25. Run this procedure at startup. It does not cause the motor to run or harm to the motor. For best result, run the procedure on a cold motor.

To run AMA

1. Enter the motor name plate data in the frequency converter, as described in *chapter 3.3.1 Basic Operational Programming*.
2. Connect terminal 37 to terminal 13.
3. Connect terminal 27 to terminal 12 or set *parameter 5-12 Terminal 27 Digital Input* to *No function*.
4. Activate the *AMA parameter 1-29 Automatic Motor Adaptation (AMA)*.
5. Choose between complete or reduced AMA.
6. Press [OK]. The display shows *Press [Hand on] to start*.
7. Press [Hand On]. A progress bar indicates that the AMA is in progress.

Stop the AMA during operation

Press [Off] - the frequency converter enters into alarm mode and the display shows that the user terminated the AMA procedure.

Successful AMA

1. The display shows *Press [OK] to finish AMA*.
2. Press [OK] exit the AMA state.

Unsuccessful AMA

1. The frequency converter enters alarm mode. A description of the alarm can be found in *chapter 7 Troubleshooting*.
2. *Report Value* in the [Alarm Log] shows that the last measuring sequence carried out by the AMA, before the frequency converter entered alarm mode. This number along with the description of the alarm assists in troubleshooting. If contacting Danfoss for service, make sure to mention number and alarm description.

NOTICE

Frequent causes of unsuccessful AMA:

- Incorrectly registered motor name plate data.
- Too great a difference between the motor power size and the frequency converter power size.

3.5 Local-control Test

⚠ WARNING

MOTOR START

Ensure that the motor, system, and any attached equipment are ready for start. Failure to ensure that the motor, system, and any attached equipment are ready for start could result in personal injury or equipment damage.

NOTICE

The [Hand On] key, on the LCP, provides a local start command to the frequency converter. The [Off] key provides the stop function. When operating in local mode, [▲] and [▼] on the LCP increase and decrease the speed output of the frequency converter. [◀] and [▶] move the display cursor in the numeric display. Moving the cursor left of the decimal point provides quicker input changes.

1. Press [Hand On].
2. Accelerate the frequency converter by pressing [▲] to full speed.
3. Note any acceleration problems.
4. Press [Off].
5. Note any deceleration problems.

In the event of acceleration problems:

- If warnings or alarms occur, see *chapter 7 Troubleshooting*.
- Check that motor data is entered correctly.

- Increase the ramp-up time in *parameter 3-41 Ramp 1 Ramp Up Time*.
- Increase current limit in *parameter 4-18 Current Limit*.
- Increase torque limit in *parameter 4-16 Torque Limit Motor Mode*.

In the event of deceleration problems:

- If warnings or alarms occur, see *chapter 7 Troubleshooting*.
- Check that motor data is entered correctly.
- Increase the ramp-down time in *parameter 3-42 Ramp 1 Ramp Down Time*.
- Enable overvoltage control in *parameter 2-17 Over-voltage Control*.

See *chapter 7.1 Warnings/Alarm Messages* for resetting the frequency converter after a trip.

3.6 System Start Up

The first three sections in this chapter conclude the procedures for applying power to the frequency converter, basic programming, set up, and functional testing. Perform the following procedures after completion of user-wiring and application programming. The following procedure is recommended after application setup by the user is completed.

CAUTION

MOTOR START

Ensure that the motor, system, and any attached equipment are ready for start. Failure to ensure that the motor, system, and any attached equipment are ready for start could result in personal injury or equipment damage.

1. Press [Auto On].
2. Ensure that external control functions are properly wired to the frequency converter and all programming completed.
3. Apply an external run command.
4. Adjust the speed reference throughout the speed range.
5. Remove the external run command.
6. Note any problems.

If warnings or alarms occur, see *chapter 7 Troubleshooting*.

4 User Interface

4.1 Local Control Panel

The LCP is the combined display and keypad. The LCP can be attached to the display connector outside the unit (without opening the enclosure) via the LCP cable/plug. The LCP is the user interface to the frequency converter.

The LCP has several user functions.

- Start, stop, and control speed when in local control
- Display operational data, status, warnings, and cautions
- Programming frequency converter functions
- Manually reset the frequency converter after a fault when auto-reset is inactive

An optional numeric LCP is also available. The numeric LCP operates in a manner similar to the LCP. See the *VLT® Decentral Drive FCD 302 Programming Guide* for details on use of the numeric LCP.

4.1.1 LCP Layout

The LCP is divided into 4 functional groups (see *Illustration 4.1*).

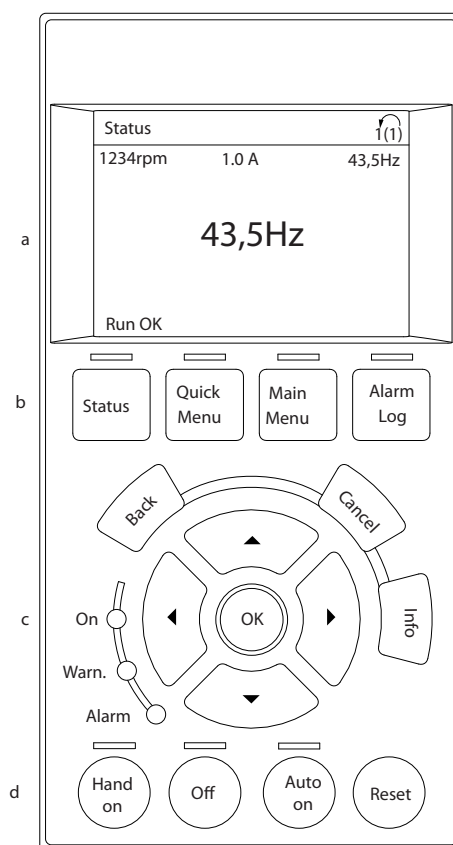

a	Display area.
b	Display menu keys for changing the display to show status options, programming, or error message history.
c	Navigation keys for programming functions, moving the display cursor, and speed control in local operation. The status indicator lights are also in this group.
d	Operational mode keys and reset.

Illustration 4.1 LCP

4.1.2 Setting LCP Display Values

The display area is activated when the frequency converter receives power from mains voltage, or an external 24 V supply.

The information displayed on the LCP can be customized for user application.

- Each display read-out has a parameter associated with it.
- The frequency converter status at the bottom line of the display is generated automatically and is not selectable. See *chapter 6.3 Status Message Definitions* for more information.

Display	Parameter number	Default setting
1.1	0-20	Motor RPMs
1.2	0-21	Motor current
1.3	0-22	Motor power (kW)
2	0-23	Motor frequency
3	0-24	Reference in percent

Table 4.1 LCP Display Values

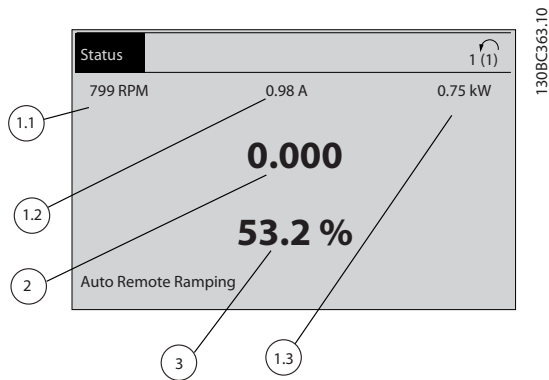

Illustration 4.2 LCP Display Values

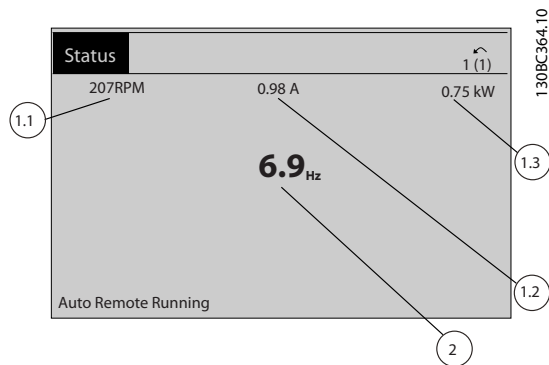

Illustration 4.3 LCP Display Values

4.1.3 Display Menu Keys

Menu keys are used for menu access for parameter set-up, toggling through status display modes during normal operation, and viewing fault log data.



Illustration 4.4 Menu Keys

Key	Function
Status	Shows operational information. <ul style="list-style-type: none"> • In Auto mode, press to toggle between status readout displays. • Press repeatedly to scroll through each status display. • Press [Status] plus [▲] or [▼] to adjust the display brightness. • The symbol in the upper right corner of the display shows the direction of motor rotation and which set-up is active. This is not programmable.
Quick Menu	Allows access to programming parameters for initial set-up instructions and many detailed application instructions. <ul style="list-style-type: none"> • Press to access <i>Q2 Quick Set-up</i> for sequenced instructions to program the basic frequency controller set-up. • Follow the sequence of parameters as presented for the function set-up.
Main Menu	Allows access to all programming parameters. <ul style="list-style-type: none"> • Press twice to access top-level index. • Press once to return to the last location accessed. • Press to enter a parameter number for direct access to that parameter.
Alarm Log	Displays a list of current warnings, the last 10 alarms, and the maintenance log. <ul style="list-style-type: none"> • For details about the frequency converter before it entered the alarm mode, select the alarm number using the navigation keys and press [OK].

Table 4.2 Function Description Menu Keys

4.1.4 Navigation Keys

Navigation keys are used for programming functions and moving the display cursor. The navigation keys also provide speed control in local (hand) operation. There are also 3 frequency converter status indicator lights in this area.

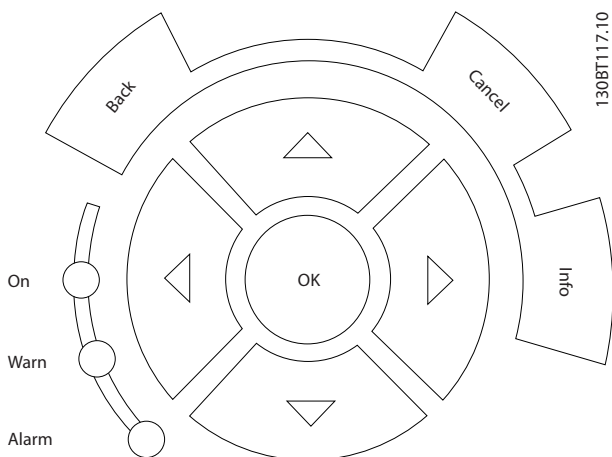

130BT117.10

Illustration 4.5 Navigation Keys

Key	Function
Back	Reverts to the previous step or list in the menu structure.
Cancel	Cancels the last change or command as long as the display mode has not changed.
Info	Press for a definition of the function being shown.
Navigation Keys	Press the 4 navigation keys to move between items in the menu.
OK	Press to access parameter groups or to enable a choice.

Table 4.3 Navigation Keys Functions

Light	Indicator	Function
Green	ON	The ON light activates when the frequency converter receives power from mains voltage, a DC bus terminal, or a 24 V external supply.
Yellow	WARN	When warning conditions are met, the yellow WARN light comes on and text appears in the display area identifying the problem.
Red	ALARM	A fault condition causes the red alarm light to flash and an alarm text is shown.

Table 4.4 Indicator Lights Functions

4.1.5 Operation Keys

Operation keys are located at the bottom of the LCP.

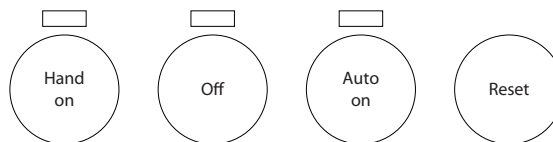

130BF046.10

Illustration 4.6 Operation Keys

Key	Function
Hand On	Starts the frequency converter in local control. <ul style="list-style-type: none"> Use the navigation keys to control frequency converter speed. An external stop signal by control input or serial communication overrides the local hand on.
Off	Stops the motor, but does not remove power to the frequency converter.
Auto On	Puts the system in remote operational mode. <ul style="list-style-type: none"> Responds to an external start command by control terminals or serial communication. Speed reference is from an external source.
Reset	Resets the frequency converter manually after a fault has been cleared.

Table 4.5 Operation Keys Functions

4.2 Back Up and Copying Parameter Settings

Programming data is stored internally in the frequency converter.

- The data can be uploaded into the LCP memory as storage back-up.
- Once stored in the LCP, the data can be downloaded back into the frequency converter.
- Data can also be downloaded into other frequency converters by connecting the LCP into those units and downloading the stored settings. (This is a quick way to program multiple units with the same settings).
- Initialization of the frequency converter to restore factory default settings does not change data stored in the LCP memory.

⚠ WARNING**UNINTENDED START**

When the frequency converter is connected to AC mains, or DC power supply, the motor may start at any time. Unintended start during programming, service, or repair work can result in death, serious injury, or property damage. The motor can start with an external switch, a serial bus command, an input reference signal from the LCP, or after a cleared fault condition.

To prevent unintended motor start:

- Disconnect the frequency converter from mains.
- Press [Off/Reset] on the LCP, before programming parameters.
- The frequency converter, motor, and any driven equipment must be fully wired and assembled when the frequency converter is connected to AC mains, or DC power supply.

4.2.1 Uploading Data to the LCP

1. Press [Off] to stop the motor before uploading or downloading data.
2. Go to *parameter 0-50 LCP Copy*.
3. Press [OK].
4. Select [1] *All to LCP*.
5. Press [OK]. A progress bar shows the uploading process.
6. Press [Hand On] or [Auto On] to return to normal operation.

4.2.2 Downloading Data from the LCP

1. Press [Off] to stop the motor before uploading or downloading data.
2. Go to *parameter 0-50 LCP Copy*.
3. Press [OK].
4. Select [2] *All from LCP*.
5. Press [OK]. A progress bar shows the downloading process.
6. Press [Hand On] or [Auto On] to return to normal operation.

4.3 Restoring Default Settings

NOTICE

Initialization restores the unit to factory default settings. Any programming, motor data, localization, and monitoring records are lost. Uploading data to the LCP provides a back-up before initialization.

Restoring the frequency converter parameter settings back to default values is done by initialization of the frequency converter. Initialization can be carried out via *parameter 14-22 Operation Mode* or manually.

- Initialization using *parameter 14-22 Operation Mode* does not change frequency converter data such as hours run, serial communication selections, personal menu settings, fault log, alarm log, and other monitoring functions.
- Using *parameter 14-22 Operation Mode* is recommended.
- Manual initialization erases all motor, programming, localization, and monitoring data and restores factory default settings.

4.3.1 Recommended Initialization

1. Press [Main Menu] twice to access parameters.
2. Scroll to *parameter 14-22 Operation Mode*.
3. Press [OK].
4. Scroll to *Initialisation*.
5. Press [OK].
6. Remove power to the unit and wait for the display to turn off.
7. Apply power to the unit.

Default parameter settings are restored during start-up. This may take slightly longer than normal.

8. Alarm 80 is shown.
9. Press [Reset] to return to operation mode.

4.3.2 Manual Initialization

1. Remove power to the unit and wait for the display to turn off.
2. Press and hold [Status], [Main Menu], and [OK] at the same time and apply power to the unit.

Factory default parameter settings are restored during start-up. This may take slightly longer than normal.

Manual initialization does not reset the following frequency converter information:

- *Parameter 15-00 Operating hours*
- *Parameter 15-03 Power Up's*
- *Parameter 15-04 Over Temp's*
- *Parameter 15-05 Over Volt's*

5 Programming

5.1 Introduction

The frequency converter is programmed for its application functions using parameters. Parameters are accessed by pressing either [Quick Menu] or [Main Menu] on the LCP. (See chapter 4 User Interface for details on using the LCP function keys.) Parameters may also be accessed through a PC using the MCT 10 Set-up Software(see chapter 5.4.1 Remote Programming with MCT 10 Set-up Software).

The quick menu is intended for initial start up. Data entered in a parameter can change the options available in the parameters following that entry. The quick menu presents easy guidelines for getting most systems up and running.

The main menu accesses all parameters and allows for advanced frequency converter applications.

5.2 Quick Setup

0-01 Language		
Option:	Function:	
		Defines display language. The frequency converter is delivered with 4 different language packages. English and German are included in all packages. English cannot be erased or manipulated.
[0] *	English	Part of language packages 1–4
[1]	Deutsch	Part of language packages 1–4
[2]	Francais	Part of language package 1
[3]	Dansk	Part of language package 1
[4]	Spanish	Part of language package 1
[5]	Italiano	Part of language package 1
[6]	Svenska	Part of language package 1
[7]	Nederlands	Part of language package 1
[10]	Chinese	Part of language package 2
[20]	Suomi	Part of language package 1
[22]	English US	Part of language package 4
[27]	Greek	Part of language package 4
[28]	Bras.port	Part of language package 4
[36]	Slovenian	Part of language package 3
[39]	Korean	Part of language package 2

0-01 Language		
Option:	Function:	
[40]	Japanese	Part of language package 2
[41]	Turkish	Part of language package 4
[42]	Trad.Chinese	Part of language package 2
[43]	Bulgarian	Part of language package 3
[44]	Srpski	Part of language package 3
[45]	Romanian	Part of language package 3
[46]	Magyar	Part of language package 3
[47]	Czech	Part of language package 3
[48]	Polski	Part of language package 4
[49]	Russian	Part of language package 3
[50]	Thai	Part of language package 2
[51]	Bahasa Indonesia	Part of language package 2
[52]	Hrvatski	Part of language package 3

1-20 Motor Power [kW]		
Range:	Function:	
Size related* [0.09 - 3000.00 kW]	<p>NOTICE</p> <p>This parameter cannot be adjusted while the motor is running.</p> <p>Enter the nominal motor power in kW according to the motor nameplate data. The default value corresponds to the nominal rated output of the frequency converter.</p> <p>This parameter is visible in the LCP if parameter 0-03 Regional Settings is set to [0] International.</p>	

1-22 Motor Voltage		
Range:	Function:	
Size related* [10 - 1000 V]	<p>Enter the nominal motor voltage according to the motor nameplate data. The default value corresponds to the nominal rated output of the frequency converter.</p>	

1-23 Motor Frequency		
Range:	Function:	
Size related* [20 - 1000 Hz]	<p>NOTICE From software version 6.72 onwards, the output frequency of the frequency converter is limited to 590 Hz.</p> <p>Select the motor frequency value from the motor nameplate data. If a value other than 50 Hz or 60 Hz is selected, adapt the load-independent settings in <i>parameter 1-50 Motor Magnetisation at Zero Speed</i> to <i>parameter 1-53 Model Shift Frequency</i>. For 87 Hz operation with 230/400 V motors, set the nameplate data for 230 V/50 Hz. To run at 87 Hz, adapt <i>parameter 4-13 Motor Speed High Limit [RPM]</i> and <i>parameter 3-03 Maximum Reference</i>.</p>	

1-24 Motor Current		
Range:	Function:	
Size related* [0.10 - 10000.00 A]	<p>NOTICE This parameter cannot be adjusted while the motor is running.</p> <p>Enter the nominal motor current value from the motor nameplate data. The data is used for calculating motor torque, motor thermal protection, and so on.</p>	

1-25 Motor Nominal Speed		
Range:	Function:	
Size related* [100 - 60000 RPM]	<p>NOTICE This parameter cannot be adjusted while the motor is running.</p> <p>Enter the nominal motor speed value from the motor nameplate data. The data is used for calculating automatic motor compensations.</p>	

1-29 Automatic Motor Adaptation (AMA)		
Option:	Function:	
	<p>The AMA function optimizes dynamic motor performance by automatically optimizing the advanced motor parameters (<i>parameter 1-30 Stator Resistance (Rs)</i> to <i>parameter 1-35 Main Reactance (Xh)</i>) at motor standstill.</p> <p>Activate the AMA function by pressing [Hand on] after selecting [1] or [2]. See also</p>	

1-29 Automatic Motor Adaptation (AMA)		
Option:	Function:	
	<p><i>chapter 3.4 Automatic Motor Adaptation</i>. After a normal sequence, the display will read: "Press [OK] to finish AMA". After pressing [OK] the frequency converter is ready for operation. This parameter cannot be adjusted while the motor is running.</p>	
[0]	OFF	
[1]	Enable complete AMA	Performs AMA of the stator resistance R_s , the rotor resistance R_r , the stator leakage reactance X_1 , the rotor leakage reactance X_2 and the main reactance X_h .
[2]	Enable reduced AMA	Performs a reduced AMA of the stator resistance R_s in the system only. Select this option if an LC filter is used between the frequency converter and the motor.

Note:

- For the best adaptation of the frequency converter, run AMA on a cold motor.
- AMA cannot be performed while the motor is running.
- AMA cannot be performed on permanent magnet motors.

NOTICE

It is important to set motor parameter group 1-2* correctly, since these parameters form part of the AMA algorithm. An AMA must be performed to achieve optimum dynamic motor performance. Depending on the power rating of the motor, it takes up to 10 min.

NOTICE

Avoid generating external torque during AMA, by disconnecting the motor shaft from the application.

NOTICE

If one of the settings in parameter group 1-2* is changed, *parameter 1-30 Stator Resistance (Rs)* to *parameter 1-39 Motor Poles*, the Advanced Motor Parameters return to default setting.

3-02 Minimum Reference		
Range:	Function:	
Size related* [-999999.999 - par. 3-03 ReferenceFeed-backUnit]	<p>Enter the minimum reference. The minimum reference is the lowest value obtainable by summing all references.</p> <p>Minimum reference is active only when <i>parameter 3-00 Reference Range</i> is set to [0] Min.- Max.</p> <p>The minimum reference unit matches:</p>	

3-02 Minimum Reference		
Range:		Function:
		<ul style="list-style-type: none"> The configuration of <i>parameter 1-00 Configuration Mode</i>: for [1] <i>Speed closed loop</i>, RPM; for [2] <i>Torque</i>, Nm. The unit selected in <i>parameter 3-01 Reference/Feedback Unit</i>. <p>If option [10] <i>Synchronization</i> is selected in <i>parameter 1-00 Configuration Mode</i>, this parameter defines the maximum speed deviation when performing the position offset defined in <i>parameter 3-26 Master Offset</i>.</p>

3-03 Maximum Reference		
Range:		Function:
Size related*	[par. 3-02 - 999999.999 ReferenceFeed-backUnit]	<p>Enter the maximum reference. The maximum reference is the highest value obtainable by summing all references.</p> <p>The maximum reference unit matches:</p> <ul style="list-style-type: none"> The configuration selected in <i>parameter 1-00 Configuration Mode</i>: For [1] <i>Speed closed loop</i>, RPM; for [2] <i>Torque</i>, Nm. The unit selected in <i>parameter 3-00 Reference Range</i>. <p>If [9] <i>Positioning</i> is selected in <i>parameter 1-00 Configuration Mode</i>, this parameter defines the default speed for positioning.</p>

3-41 Ramp 1 Ramp Up Time		
Range:		Function:
Size related*	[1.00 - 3600 s]	<p>Enter the ramp-up time, that is, the acceleration time from 0 RPM to the synchronous motor speed n_s. Select a ramp-up time which prevents the output current from exceeding the current limit in <i>parameter 4-18 Current Limit</i> during ramping. The value 0.00 corresponds to 0.01 s in speed mode. See ramp-down time in <i>parameter 3-42 Ramp 1 Ramp Down Time</i>.</p> $Par. 3 - 41 = \frac{t_{acc} [s] \times n_s [RPM]}{ref [RPM]}$

3-42 Ramp 1 Ramp Down Time		
Range:		Function:
Size related*	[1.00 - 3600 s]	<p>Enter the ramp-down time, that is, the deceleration time from the synchronous motor speed n_s to 0 RPM. Select a ramp-down time such that no overvoltage occurs in the inverter due to regenerative operation of the motor, and such that the generated current does not exceed the current limit set in <i>parameter 4-18 Current Limit</i>. The value 0.00 corresponds to 0.01 s in speed mode. See ramp-up time in <i>parameter 3-41 Ramp 1 Ramp Up Time</i>.</p> $Par. 3 - 42 = \frac{t_{dec} [s] \times n_s [RPM]}{ref [RPM]}$

5-12 Terminal 27 Digital Input

Option:	Function:																																																																		
	Select the function from the available digital input range.																																																																		
	<table border="1"> <tr><td>No operation</td><td>[0]</td></tr> <tr><td>Reset</td><td>[1]</td></tr> <tr><td>Coast inverse</td><td>[2]</td></tr> <tr><td>Coast and reset inverse</td><td>[3]</td></tr> <tr><td>Quick stop inverse</td><td>[4]</td></tr> <tr><td>DC-brake inverse</td><td>[5]</td></tr> <tr><td>Stop inverse</td><td>[6]</td></tr> <tr><td>Start</td><td>[8]</td></tr> <tr><td>Latched start</td><td>[9]</td></tr> <tr><td>Reversing</td><td>[10]</td></tr> <tr><td>Start reversing</td><td>[11]</td></tr> <tr><td>Enable start forward</td><td>[12]</td></tr> <tr><td>Enable start reverse</td><td>[13]</td></tr> <tr><td>Jog</td><td>[14]</td></tr> <tr><td>Preset ref bit 0</td><td>[16]</td></tr> <tr><td>Preset ref bit 1</td><td>[17]</td></tr> <tr><td>Preset ref bit 2</td><td>[18]</td></tr> <tr><td>Freeze reference</td><td>[19]</td></tr> <tr><td>Freeze output</td><td>[20]</td></tr> <tr><td>Speed up</td><td>[21]</td></tr> <tr><td>Speed down</td><td>[22]</td></tr> <tr><td>Set-up select bit 0</td><td>[23]</td></tr> <tr><td>Set-up select bit 1</td><td>[24]</td></tr> <tr><td>Catch up</td><td>[28]</td></tr> <tr><td>Slow down</td><td>[29]</td></tr> <tr><td>Pulse input</td><td>[32]</td></tr> <tr><td>Ramp bit 0</td><td>[34]</td></tr> <tr><td>Ramp bit 1</td><td>[35]</td></tr> <tr><td>Mains failure inverse</td><td>[36]</td></tr> <tr><td>DigiPot Increase</td><td>[55]</td></tr> <tr><td>DigiPot Decrease</td><td>[56]</td></tr> <tr><td>DigiPot Clear</td><td>[57]</td></tr> <tr><td>Reset Counter A</td><td>[62]</td></tr> </table>	No operation	[0]	Reset	[1]	Coast inverse	[2]	Coast and reset inverse	[3]	Quick stop inverse	[4]	DC-brake inverse	[5]	Stop inverse	[6]	Start	[8]	Latched start	[9]	Reversing	[10]	Start reversing	[11]	Enable start forward	[12]	Enable start reverse	[13]	Jog	[14]	Preset ref bit 0	[16]	Preset ref bit 1	[17]	Preset ref bit 2	[18]	Freeze reference	[19]	Freeze output	[20]	Speed up	[21]	Speed down	[22]	Set-up select bit 0	[23]	Set-up select bit 1	[24]	Catch up	[28]	Slow down	[29]	Pulse input	[32]	Ramp bit 0	[34]	Ramp bit 1	[35]	Mains failure inverse	[36]	DigiPot Increase	[55]	DigiPot Decrease	[56]	DigiPot Clear	[57]	Reset Counter A	[62]
No operation	[0]																																																																		
Reset	[1]																																																																		
Coast inverse	[2]																																																																		
Coast and reset inverse	[3]																																																																		
Quick stop inverse	[4]																																																																		
DC-brake inverse	[5]																																																																		
Stop inverse	[6]																																																																		
Start	[8]																																																																		
Latched start	[9]																																																																		
Reversing	[10]																																																																		
Start reversing	[11]																																																																		
Enable start forward	[12]																																																																		
Enable start reverse	[13]																																																																		
Jog	[14]																																																																		
Preset ref bit 0	[16]																																																																		
Preset ref bit 1	[17]																																																																		
Preset ref bit 2	[18]																																																																		
Freeze reference	[19]																																																																		
Freeze output	[20]																																																																		
Speed up	[21]																																																																		
Speed down	[22]																																																																		
Set-up select bit 0	[23]																																																																		
Set-up select bit 1	[24]																																																																		
Catch up	[28]																																																																		
Slow down	[29]																																																																		
Pulse input	[32]																																																																		
Ramp bit 0	[34]																																																																		
Ramp bit 1	[35]																																																																		
Mains failure inverse	[36]																																																																		
DigiPot Increase	[55]																																																																		
DigiPot Decrease	[56]																																																																		
DigiPot Clear	[57]																																																																		
Reset Counter A	[62]																																																																		

5-12 Terminal 27 Digital Input

Option: Function:

		Reset Counter B	[65]
--	--	-----------------	------

5.3 Parameter Lists

Changes during operation

“TRUE” means that the parameter can be changed while the frequency converter is in operation and “FALSE” means that it must be stopped before a change can be made.

4-Set-up

'All set-up': the parameters can be set individually in each of the four set-ups, that is, one single parameter can have four different data values.

In all set-ups '1 set-up': data value is the same.

Conversion index

This number refers to a conversion figure used when writing or reading to and from the frequency converter.

Conv. index	Conv. factor
100	1
67	1/60
6	1000000
5	100000
4	10000
3	1000
2	100
1	10
0	1
-1	0.1
-2	0.01
-3	0.001
-4	0.0001
-5	0.00001
-6	0.000001

Data type	Description	Type
2	Integer 8	Int8
3	Integer 16	Int16
4	Integer 32	Int32
5	Unsigned 8	UInt8
6	Unsigned 16	UInt16
7	Unsigned 32	UInt32
9	Visible String	VisStr
33	Normalized value 2 bytes	N2
35	Bit sequence of 16 boolean variables	V2
54	Time difference w/o date	TimD

See the *VLT® Decentral Drive FCD 302 Design Guide* for further information about data types 33, 35 and 54.

Parameters for the frequency converter are grouped into various parameter groups for easy selection of the correct parameters for optimized operation of the frequency converter.

- 0-** Operation and Display parameters for basic frequency converter settings
- 1-** Load and Motor parameters
- 2-** Brakes
- 3-** References and ramping parameters, includes DigiPot function
- 4-** Limits Warnings, setting of limits and warning parameters
- 5-** Digital inputs and outputs, includes relay controls
- 6-** Analog inputs and outputs
- 7-** Controls, setting parameters for speed and process controls
- 8-** Communication and option parameters, setting of FC RS485 and FC USB port parameters.
- 9-** Profibus
- 13-** Smart Logic Control parameters
- 14-** Special function parameters
- 15-** Drive information parameters
- 16-** Read out parameters
- 17-** Motor Feedback Option parameters
- 30-** Special Features

5.3.1 0-** Operation/Display

Par. No. #	Parameter description	Default value	4-set-up	Change during operation	Conversion index	Type
0-0* Basic Settings						
0-01	Language	[0] English	1 set-up	TRUE	-	Uint8
0-02	Motor Speed Unit	[0] RPM	2 set-ups	FALSE	-	Uint8
0-03	Regional Settings	[0] International	2 set-ups	FALSE	-	Uint8
0-04	Operating State at Power-up (Hand)	[1] Forced stop, ref=old	All set-ups	TRUE	-	Uint8
0-09	Performance Monitor	0.0%	All set-ups	TRUE	-1	Uint16
0-1* Set-up Operations						
0-10	Active Set-up	[1] Set-up 1	1 set-up	TRUE	-	Uint8
0-11	Edit Set-up	[1] Set-up 1	All set-ups	TRUE	-	Uint8
0-12	This Set-up Linked to	[0] Not linked	All set-ups	FALSE	-	Uint8
0-13	Readout: Linked Set-ups	0 N/A	All set-ups	FALSE	0	Uint16
0-14	Readout: Edit Set-ups / Channel	0 N/A	All set-ups	TRUE	0	Int32
0-2* LCP Display						
0-20	Display Line 1.1 Small	1617	All set-ups	TRUE	-	Uint16
0-21	Display Line 1.2 Small	1614	All set-ups	TRUE	-	Uint16
0-22	Display Line 1.3 Small	1610	All set-ups	TRUE	-	Uint16
0-23	Display Line 2 Large	1613	All set-ups	TRUE	-	Uint16
0-24	Display Line 3 Large	1602	All set-ups	TRUE	-	Uint16
0-25	My Personal Menu	SR	1 set-up	TRUE	0	Uint16
0-3* LCP Custom Readout						
0-30	Unit for User-defined Readout	[0] None	All set-ups	TRUE	-	Uint8
0-31	Min Value of User-defined Readout	0.00 CustomReadoutUnit	All set-ups	TRUE	-2	Int32
0-32	Max Value of User-defined Readout	100.00 CustomReadoutUnit	All set-ups	TRUE	-2	Int32
0-37	Display Text 1	0 N/A	1 set-up	TRUE	0	VisStr[25]
0-38	Display Text 2	0 N/A	1 set-up	TRUE	0	VisStr[25]
0-39	Display Text 3	0 N/A	1 set-up	TRUE	0	VisStr[25]
0-4* LCP Keypad						
0-40	[Hand on] Key on LCP	null	All set-ups	TRUE	-	Uint8
0-41	[Off] Key on LCP	null	All set-ups	TRUE	-	Uint8
0-42	[Auto on] Key on LCP	null	All set-ups	TRUE	-	Uint8
0-43	[Reset] Key on LCP	null	All set-ups	TRUE	-	Uint8
0-44	[Off/Reset] Key on LCP	null	All set-ups	TRUE	-	Uint8
0-45	[Drive Bypass] Key on LCP	null	All set-ups	TRUE	-	Uint8
0-5* Copy/Save						
0-50	LCP Copy	[0] No copy	All set-ups	FALSE	-	Uint8
0-51	Set-up Copy	[0] No copy	All set-ups	FALSE	-	Uint8
0-6* Password						
0-60	Main Menu Password	100 N/A	1 set-up	TRUE	0	Int16
0-61	Access to Main Menu w/o Password	[0] Full access	1 set-up	TRUE	-	Uint8
0-65	Quick Menu Password	200 N/A	1 set-up	TRUE	0	Int16
0-66	Access to Quick Menu w/o Password	[0] Full access	1 set-up	TRUE	-	Uint8
0-67	Bus Password Access	0 N/A	All set-ups	TRUE	0	Uint16

Table 5.1

5.3.2 1-** Load/Motor

5

Parameter #	Parameter description	Default value	4 set-up	Change during operation	Conversion index	Type
1-0* General Settings						
1-00	Configuration Mode	ExpressionLimit	All set-ups	TRUE	-	Uint8
1-01	Motor Control Principle	ExpressionLimit	All set-ups	FALSE	-	Uint8
1-02	Flux Motor Feedback Source	[1] 24V encoder	All set-ups	FALSE	-	Uint8
1-03	Torque Characteristics	[0] Constant torque	All set-ups	TRUE	-	Uint8
1-04	Overload Mode	[0] High torque	All set-ups	FALSE	-	Uint8
1-05	Local Mode Configuration	[2] As mode par 1-00	All set-ups	TRUE	-	Uint8
1-06	Clockwise Direction	[0] Normal	All set-ups	FALSE	-	Uint8
1-07	Motor Angle Offset Adjust	[0] Manual	All set-ups	FALSE	-	Uint8
1-1* Special Settings						
1-10	Motor Construction	[0] Asynchron	All set-ups	FALSE	-	Uint8
1-11	Motor Model	ExpressionLimit	All set-ups	FALSE	-	Uint8
1-18	Min. Current at No Load	0 %	All set-ups	TRUE	0	Uint16
1-2* Motor Data						
1-20	Motor Power [kW]	ExpressionLimit	All set-ups	FALSE	1	Uint32
1-21	Motor Power [HP]	ExpressionLimit	All set-ups	FALSE	-2	Uint32
1-22	Motor Voltage	ExpressionLimit	All set-ups	FALSE	0	Uint16
1-23	Motor Frequency	ExpressionLimit	All set-ups	FALSE	0	Uint16
1-24	Motor Current	ExpressionLimit	All set-ups	FALSE	-2	Uint32
1-25	Motor Nominal Speed	ExpressionLimit	All set-ups	FALSE	67	Uint16
1-26	Motor Cont. Rated Torque	ExpressionLimit	All set-ups	FALSE	-1	Uint32
1-29	Automatic Motor Adaptation (AMA)	[0] Off	All set-ups	FALSE	-	Uint8
1-3* Adv. Motor Data						
1-30	Stator Resistance (Rs)	ExpressionLimit	All set-ups	FALSE	-4	Uint32
1-31	Rotor Resistance (Rr)	ExpressionLimit	All set-ups	FALSE	-4	Uint32
1-33	Stator Leakage Reactance (X1)	ExpressionLimit	All set-ups	FALSE	-4	Uint32
1-34	Rotor Leakage Reactance (X2)	ExpressionLimit	All set-ups	FALSE	-4	Uint32
1-35	Main Reactance (Xh)	ExpressionLimit	All set-ups	FALSE	-4	Uint32
1-36	Iron Loss Resistance (Rfe)	ExpressionLimit	All set-ups	FALSE	-3	Uint32
1-37	d-axis Inductance (Ld)	ExpressionLimit	All set-ups	FALSE	-4	Int32
1-39	Motor Poles	ExpressionLimit	All set-ups	FALSE	0	Uint8
1-40	Back EMF at 1000 RPM	ExpressionLimit	All set-ups	FALSE	0	Uint16
1-41	Motor Angle Offset	0 N/A	All set-ups	TRUE	0	Int16
1-46	Position Detection Gain	100 %	All set-ups	TRUE	0	Uint16
1-47	Torque Calibration	ExpressionLimit	All set-ups	TRUE	-	Uint8
1-5* Load Indep. Setting						
1-50	Motor Magnetisation at Zero Speed	100 %	All set-ups	TRUE	0	Uint16
1-51	Min Speed Normal Magnetising [RPM]	ExpressionLimit	All set-ups	TRUE	67	Uint16
1-52	Min Speed Normal Magnetising [Hz]	ExpressionLimit	All set-ups	TRUE	-1	Uint16
1-53	Model Shift Frequency	ExpressionLimit	All set-ups	FALSE	-1	Uint16
1-54	Voltage reduction in fieldweakening	0 V	All set-ups	FALSE	0	Uint8
1-55	U/f Characteristic - U	ExpressionLimit	All set-ups	TRUE	-1	Uint16
1-56	U/f Characteristic - F	ExpressionLimit	All set-ups	TRUE	-1	Uint16
1-57	Torque Estimation Time Constant	150 ms	All set-ups	TRUE	-3	Uint16
1-58	Flying Start Test Pulses Current	ExpressionLimit	All set-ups	FALSE	0	Uint16
1-59	Flying Start Test Pulses Frequency	ExpressionLimit	All set-ups	FALSE	0	Uint16
1-6* Load Depen. Setting						
1-60	Low Speed Load Compensation	100 %	All set-ups	TRUE	0	Int16

1-61	High Speed Load Compensation	100 %	All set-ups	TRUE	0	Int16
1-62	Slip Compensation	ExpressionLimit	All set-ups	TRUE	0	Int16
1-63	Slip Compensation Time Constant	ExpressionLimit	All set-ups	TRUE	-2	Uint16
1-64	Resonance Damping	ExpressionLimit	All set-ups	TRUE	0	Uint16
1-65	Resonance Damping Time Constant	5 ms	All set-ups	TRUE	-3	Uint8
1-66	Min. Current at Low Speed	ExpressionLimit	All set-ups	TRUE	0	Uint32
1-67	Load Type	[0] Passive load	All set-ups	TRUE	-	Uint8
1-68	Motor Inertia	0 kgm ²	All set-ups	TRUE	-4	Uint32
1-69	System Inertia	ExpressionLimit	All set-ups	TRUE	-4	Uint32
1-7* Start Adjustments						
1-70	PM Start Mode	[0] Rotor Detection	All set-ups	TRUE	-	Uint8
1-71	Start Delay	0 s	All set-ups	TRUE	-1	Uint8
1-72	Start Function	[2] Coast/delay time	All set-ups	TRUE	-	Uint8
1-73	Flying Start	ExpressionLimit	All set-ups	FALSE	-	Uint8
1-74	Start Speed [RPM]	ExpressionLimit	All set-ups	TRUE	67	Uint16
1-75	Start Speed [Hz]	ExpressionLimit	All set-ups	TRUE	-1	Uint16
1-76	Start Current	0 A	All set-ups	TRUE	-2	Uint32
1-8* Stop Adjustments						
1-80	Function at Stop	[0] Coast	All set-ups	TRUE	-	Uint8
1-81	Min Speed for Function at Stop [RPM]	ExpressionLimit	All set-ups	TRUE	67	Uint16
1-82	Min Speed for Function at Stop [Hz]	ExpressionLimit	All set-ups	TRUE	-1	Uint16
1-83	Precise Stop Function	[0] Precise ramp stop	All set-ups	FALSE	-	Uint8
1-84	Precise Stop Counter Value	100000 N/A	All set-ups	TRUE	0	Uint32
1-85	Precise Stop Speed Compensation Delay	10 ms	All set-ups	TRUE	-3	Uint8
1-9* Motor Temperature						
1-90	Motor Thermal Protection	ExpressionLimit	All set-ups	TRUE	-	Uint8
1-91	Motor External Fan	ExpressionLimit	All set-ups	TRUE	-	Uint8
1-93	Thermistor Resource	[0] None	All set-ups	TRUE	-	Uint8
1-94	ATEX ETR cur.lim. speed reduction	0 %	2 set-ups	TRUE	-1	Uint16
1-95	KTY Sensor Type	[0] KTY Sensor 1	All set-ups	TRUE	-	Uint8
1-96	KTY Thermistor Resource	[0] None	All set-ups	TRUE	-	Uint8
1-97	KTY Threshold level	80 °C	1 set-up	TRUE	100	Int16
1-98	ATEX ETR interpol. points freq.	ExpressionLimit	1 set-up	TRUE	-1	Uint16
1-99	ATEX ETR interpol points current	ExpressionLimit	2 set-ups	TRUE	0	Uint16

5.3.3 2-** Brakes

5

Parameter #	Parameter description	Default value	4 set-up	Change during operation	Conversion index	Type
2-0* DC-Brake						
2-00	DC Hold Current	50 %	All set-ups	TRUE	0	Uint8
2-01	DC Brake Current	50 %	All set-ups	TRUE	0	Uint16
2-02	DC Braking Time	10 s	All set-ups	TRUE	-1	Uint16
2-03	DC Brake Cut In Speed [RPM]	ExpressionLimit	All set-ups	TRUE	67	Uint16
2-04	DC Brake Cut In Speed [Hz]	ExpressionLimit	All set-ups	TRUE	-1	Uint16
2-05	Maximum Reference	MaxReference (P303)	All set-ups	TRUE	-3	Int32
2-06	Parking Current	50 %	All set-ups	TRUE	0	Uint16
2-07	Parking Time	3 s	All set-ups	TRUE	-1	Uint16
2-1* Brake Energy Funct.						
2-10	Brake Function	ExpressionLimit	All set-ups	TRUE	-	Uint8
2-11	Brake Resistor (ohm)	ExpressionLimit	All set-ups	TRUE	0	Uint16
2-12	Brake Power Limit (kW)	ExpressionLimit	All set-ups	TRUE	0	Uint32
2-13	Brake Power Monitoring	[0] Off	All set-ups	TRUE	-	Uint8
2-15	Brake Check	[0] Off	All set-ups	TRUE	-	Uint8
2-16	AC brake Max. Current	100 %	All set-ups	TRUE	-1	Uint32
2-17	Over-voltage Control	[0] Disabled	All set-ups	TRUE	-	Uint8
2-18	Brake Check Condition	[0] At Power Up	All set-ups	TRUE	-	Uint8
2-19	Over-voltage Gain	100 %	All set-ups	TRUE	0	Uint16
2-2* Mechanical Brake						
2-20	Release Brake Current	ImaxVLT (P1637)	All set-ups	TRUE	-2	Uint32
2-21	Activate Brake Speed [RPM]	ExpressionLimit	All set-ups	TRUE	67	Uint16
2-22	Activate Brake Speed [Hz]	ExpressionLimit	All set-ups	TRUE	-1	Uint16
2-23	Activate Brake Delay	0 s	All set-ups	TRUE	-1	Uint8
2-24	Stop Delay	0 s	All set-ups	TRUE	-1	Uint8
2-25	Brake Release Time	0.20 s	All set-ups	TRUE	-2	Uint16
2-26	Torque Ref	0 %	All set-ups	TRUE	-2	Int16
2-27	Torque Ramp Up Time	0.2 s	All set-ups	TRUE	-1	Uint8
2-28	Gain Boost Factor	1 N/A	All set-ups	TRUE	-2	Uint16
2-29	Torque Ramp Down Time	0 s	All set-ups	TRUE	-1	Uint8
2-3* Adv. Mech Brake						
2-30	Position P Start Proportional Gain	0.0000 N/A	All set-ups	TRUE	-4	Uint32
2-31	Speed PID Start Proportional Gain	0.0150 N/A	All set-ups	TRUE	-4	Uint32
2-32	Speed PID Start Integral Time	200.0 ms	All set-ups	TRUE	-4	Uint32
2-33	Speed PID Start Lowpass Filter Time	10.0 ms	All set-ups	TRUE	-4	Uint16

5.3.4 3-** Reference/Ramps

Parameter #	Parameter description	Default value	4 set-up	Change during operation	Conversion index	Type
3-0* Reference Limits						
3-00	Reference Range	ExpressionLimit	All set-ups	TRUE	-	Uint8
3-01	Reference/Feedback Unit	ExpressionLimit	All set-ups	TRUE	-	Uint8
3-02	Minimum/Offset Reference	ExpressionLimit	All set-ups	TRUE	-3	Int32
3-03	Maximum Reference	ExpressionLimit	All set-ups	TRUE	-3	Int32
3-04	Reference Function	[0] Sum	All set-ups	TRUE	-	Uint8
3-05	On Reference Window	ExpressionLimit	All set-ups	TRUE	-3	Int32
3-06	Minimum Position	-100000 Custom-ReadoutUnit2	All set-ups	FALSE	0	Int32
3-07	Maximum Position	100000 CustomReadoutUnit2	All set-ups	FALSE	0	Int32
3-08	On Target Window	5 CustomReadoutUnit2	All set-ups	TRUE	0	Int32
3-09	On Target Time	1 ms	All set-ups	TRUE	-3	Uint16
3-1* References						
3-10	Preset Reference	0 %	All set-ups	TRUE	-2	Int16
3-11	Jog Speed [Hz]	ExpressionLimit	All set-ups	TRUE	-1	Uint16
3-12	Catch up/slow Down Value	0 %	All set-ups	TRUE	-2	Int16
3-13	Reference Site	[0] Linked to Hand / Auto	All set-ups	TRUE	-	Uint8
3-14	Preset Relative Reference	0 %	All set-ups	TRUE	-2	Int32
3-15	Reference Resource 1	ExpressionLimit	All set-ups	TRUE	-	Uint8
3-16	Reference Resource 2	ExpressionLimit	All set-ups	TRUE	-	Uint8
3-17	Reference Resource 3	ExpressionLimit	All set-ups	TRUE	-	Uint8
3-18	Relative Scaling Reference Resource	[0] No function	All set-ups	TRUE	-	Uint8
3-19	Jog Speed [RPM]	ExpressionLimit	All set-ups	TRUE	67	Uint16
3-2* References II						
3-20	Preset Target	0 CustomReadoutUnit2	All set-ups	TRUE	0	Int32
3-21	Touch Target	0 CustomReadoutUnit2	All set-ups	TRUE	0	Int32
3-22	Master Scale Numerator	1 N/A	All set-ups	TRUE	0	Int32
3-23	Master Scale Denominator	1 N/A	All set-ups	TRUE	0	Int32
3-24	Master Lowpass Filter Time	20 ms	All set-ups	TRUE	-4	Uint16
3-25	Master Bus Resolution	65536 N/A	All set-ups	FALSE	0	Uint32
3-26	Master Offset	0 CustomReadoutUnit2	All set-ups	TRUE	0	Int32
3-4* Ramp 1						
3-40	Ramp 1 Type	[0] Linear	All set-ups	TRUE	-	Uint8
3-41	Ramp 1 Ramp Up Time	ExpressionLimit	All set-ups	TRUE	-2	Uint32
3-42	Ramp 1 Ramp Down Time	ExpressionLimit	All set-ups	TRUE	-2	Uint32
3-45	Ramp 1 S-ramp Ratio at Accel. Start	50 %	All set-ups	TRUE	0	Uint8
3-46	Ramp 1 S-ramp Ratio at Accel. End	50 %	All set-ups	TRUE	0	Uint8
3-47	Ramp 1 S-ramp Ratio at Decel. Start	50 %	All set-ups	TRUE	0	Uint8
3-48	Ramp 1 S-ramp Ratio at Decel. End	50 %	All set-ups	TRUE	0	Uint8
3-5* Ramp 2						
3-50	Ramp 2 Type	[0] Linear	All set-ups	TRUE	-	Uint8
3-51	Ramp 2 Ramp Up Time	ExpressionLimit	All set-ups	TRUE	-2	Uint32
3-52	Ramp 2 Ramp Down Time	ExpressionLimit	All set-ups	TRUE	-2	Uint32
3-55	Ramp 2 S-ramp Ratio at Accel. Start	50 %	All set-ups	TRUE	0	Uint8

3-56	Ramp 2 S-ramp Ratio at Accel. End	50 %	All set-ups	TRUE	0	Uint8
3-57	Ramp 2 S-ramp Ratio at Decel. Start	50 %	All set-ups	TRUE	0	Uint8
3-58	Ramp 2 S-ramp Ratio at Decel. End	50 %	All set-ups	TRUE	0	Uint8
3-6* Ramp 3						
3-60	Ramp 3 Type	[0] Linear	All set-ups	TRUE	-	Uint8
3-61	Ramp 3 Ramp up Time	ExpressionLimit	All set-ups	TRUE	-2	Uint32
3-62	Ramp 3 Ramp down Time	ExpressionLimit	All set-ups	TRUE	-2	Uint32
3-65	Ramp 3 S-ramp Ratio at Accel. Start	50 %	All set-ups	TRUE	0	Uint8
3-66	Ramp 3 S-ramp Ratio at Accel. End	50 %	All set-ups	TRUE	0	Uint8
3-67	Ramp 3 S-ramp Ratio at Decel. Start	50 %	All set-ups	TRUE	0	Uint8
3-68	Ramp 3 S-ramp Ratio at Decel. End	50 %	All set-ups	TRUE	0	Uint8
3-7* Ramp 4						
3-70	Ramp 4 Type	[0] Linear	All set-ups	TRUE	-	Uint8
3-71	Ramp 4 Ramp up Time	ExpressionLimit	All set-ups	TRUE	-2	Uint32
3-72	Ramp 4 Ramp Down Time	ExpressionLimit	All set-ups	TRUE	-2	Uint32
3-75	Ramp 4 S-ramp Ratio at Accel. Start	50 %	All set-ups	TRUE	0	Uint8
3-76	Ramp 4 S-ramp Ratio at Accel. End	50 %	All set-ups	TRUE	0	Uint8
3-77	Ramp 4 S-ramp Ratio at Decel. Start	50 %	All set-ups	TRUE	0	Uint8
3-78	Ramp 4 S-ramp Ratio at Decel. End	50 %	All set-ups	TRUE	0	Uint8
3-8* Other Ramps						
3-80	Jog/Homing Ramp Time	ExpressionLimit	All set-ups	TRUE	-2	Uint32
3-81	Quick Stop Ramp Time	ExpressionLimit	2 set-ups	TRUE	-2	Uint32
3-82	Quick Stop Ramp Type	[0] Linear	All set-ups	TRUE	-	Uint8
3-83	Quick Stop S-ramp Ratio at Decel. Start	50 %	All set-ups	TRUE	0	Uint8
3-84	Quick Stop S-ramp Ratio at Decel. End	50 %	All set-ups	TRUE	0	Uint8
3-89	Ramp Lowpass Filter Time	1 ms	All set-ups	TRUE	-4	Uint16
3-9* Digital Pot.Meter						
3-90	Step Size	0.10 %	All set-ups	TRUE	-2	Uint16
3-91	Ramp Time	1 s	All set-ups	TRUE	-2	Uint32
3-92	Power Restore	[0] Off	All set-ups	TRUE	-	Uint8
3-93	Maximum Limit	100 %	All set-ups	TRUE	0	Int16
3-94	Minimum Limit	-100 %	All set-ups	TRUE	0	Int16
3-95	Ramp Delay	ExpressionLimit	All set-ups	TRUE	-3	TimD

5.3.5 4-** Limits/Warnings

Parameter #	Parameter description	Default value	4 set-up	Change during operation	Conversion index	Type
4-1* Motor Limits						
4-10	Motor Speed Direction	ExpressionLimit	All set-ups	FALSE	-	Uint8
4-11	Motor Speed Low Limit [RPM]	ExpressionLimit	All set-ups	TRUE	67	Uint16
4-12	Motor Speed Low Limit [Hz]	ExpressionLimit	All set-ups	TRUE	-1	Uint16
4-13	Motor Speed High Limit [RPM]	ExpressionLimit	All set-ups	TRUE	67	Uint16
4-14	Motor Speed High Limit [Hz]	ExpressionLimit	All set-ups	TRUE	-1	Uint16
4-16	Torque Limit Motor Mode	ExpressionLimit	All set-ups	TRUE	-1	Uint16
4-17	Torque Limit Generator Mode	100 %	All set-ups	TRUE	-1	Uint16
4-18	Current Limit	ExpressionLimit	All set-ups	TRUE	-1	Uint32
4-19	Max Output Frequency	ExpressionLimit	All set-ups	FALSE	-1	Uint16
4-2* Limit Factors						
4-20	Torque Limit Factor Source	[0] No function	All set-ups	TRUE	-	Uint8
4-21	Speed Limit Factor Source	[0] No function	All set-ups	TRUE	-	Uint8
4-23	Brake Check Limit Factor Source	[0] DC-link voltage	All set-ups	TRUE	-	Uint8
4-24	Brake Check Limit Factor	98 %	All set-ups	TRUE	0	Uint8
4-3* Motor Speed Mon.						
4-30	Motor Feedback Loss Function	[2] Trip	All set-ups	TRUE	-	Uint8
4-31	Motor Feedback Speed Error	300 RPM	All set-ups	TRUE	67	Uint16
4-32	Motor Feedback Loss Timeout	0.05 s	All set-ups	TRUE	-2	Uint16
4-34	Tracking Error Function	ExpressionLimit	All set-ups	TRUE	-	Uint8
4-35	Tracking Error	10 RPM	All set-ups	TRUE	67	Uint16
4-36	Tracking Error Timeout	1 s	All set-ups	TRUE	-2	Uint16
4-37	Tracking Error Ramping	100 RPM	All set-ups	TRUE	67	Uint16
4-38	Tracking Error Ramping Timeout	1 s	All set-ups	TRUE	-2	Uint16
4-39	Tracking Error After Ramping Timeout	5 s	All set-ups	TRUE	-2	Uint16
4-4* Speed Monitor						
4-43	Motor Speed Monitor Function	[0] Disabled	All set-ups	TRUE	-	Uint8
4-44	Motor Speed Monitor Max	100 RPM	All set-ups	TRUE	67	Uint16
4-45	Motor Speed Monitor Timeout	0.1 s	All set-ups	TRUE	-2	Uint16
4-5* Adj. Warnings						
4-50	Warning Current Low	0 A	All set-ups	TRUE	-2	Uint32
4-51	Warning Current High	ImaxVLT (P1637)	All set-ups	TRUE	-2	Uint32
4-52	Warning Speed Low	0 RPM	All set-ups	TRUE	67	Uint16
4-53	Warning Speed High	ExpressionLimit	All set-ups	TRUE	67	Uint16
4-54	Warning Reference Low	-999999.999 N/A	All set-ups	TRUE	-3	Int32
4-55	Warning Reference High	999999.999 N/A	All set-ups	TRUE	-3	Int32
4-56	Warning Feedback Low	-999999.999 ReferenceFeed-backUnit	All set-ups	TRUE	-3	Int32
4-57	Warning Feedback High	999999.999 ReferenceFeed-backUnit	All set-ups	TRUE	-3	Int32
4-58	Missing Motor Phase Function	ExpressionLimit	All set-ups	TRUE	-	Uint8
4-6* Speed Bypass						
4-60	Bypass Speed From [RPM]	ExpressionLimit	All set-ups	TRUE	67	Uint16
4-61	Bypass Speed From [Hz]	ExpressionLimit	All set-ups	TRUE	-1	Uint16
4-62	Bypass Speed To [RPM]	ExpressionLimit	All set-ups	TRUE	67	Uint16
4-63	Bypass Speed To [Hz]	ExpressionLimit	All set-ups	TRUE	-1	Uint16
4-7* Position Monitor						

4-70	Position Error Function	[0] Disabled	All set-ups	TRUE	-	Uint8
4-71	Maximum Position Error	1000 CustomRea- doutUnit2	All set-ups	TRUE	0	Int32
4-72	Position Error Timeout	0.100 s	All set-ups	TRUE	-3	Uint16
4-73	Position Limit Function	[3] Abs. Pos. Mode Stop	All set-ups	TRUE	-	Uint8

5.3.6 5-** Digital In/Out

5

Parameter #	Parameter description	Default value	4 set-up	Change during operation	Conversion index	Type
5-0* Digital I/O mode						
5-00	Digital I/O Mode	[0] PNP	All set-ups	FALSE	-	Uint8
5-01	Terminal 27 Mode	[0] Input	All set-ups	TRUE	-	Uint8
5-02	Terminal 29 Mode	[0] Input	All set-ups	TRUE	-	Uint8
5-1* Digital Inputs						
5-10	Terminal 18 Digital Input	ExpressionLimit	All set-ups	TRUE	-	Uint8
5-11	Terminal 19 Digital Input	ExpressionLimit	All set-ups	TRUE	-	Uint8
5-12	Terminal 27 Digital Input	ExpressionLimit	All set-ups	TRUE	-	Uint8
5-13	Terminal 29 Digital Input	ExpressionLimit	All set-ups	TRUE	-	Uint8
5-14	Terminal 32 Digital Input	ExpressionLimit	All set-ups	TRUE	-	Uint8
5-15	Terminal 33 Digital Input	ExpressionLimit	All set-ups	TRUE	-	Uint8
5-16	Terminal X30/2 Digital Input	ExpressionLimit	All set-ups	TRUE	-	Uint8
5-17	Terminal X30/3 Digital Input	ExpressionLimit	All set-ups	TRUE	-	Uint8
5-18	Terminal X30/4 Digital Input	ExpressionLimit	All set-ups	TRUE	-	Uint8
5-19	Terminal 37 Safe Stop	ExpressionLimit	1 set-up	TRUE	-	Uint8
5-20	Terminal X46/1 Digital Input	[0] No operation	All set-ups	TRUE	-	Uint8
5-21	Terminal X46/3 Digital Input	[0] No operation	All set-ups	TRUE	-	Uint8
5-22	Terminal X46/5 Digital Input	[0] No operation	All set-ups	TRUE	-	Uint8
5-23	Terminal X46/7 Digital Input	[0] No operation	All set-ups	TRUE	-	Uint8
5-24	Terminal X46/9 Digital Input	[0] No operation	All set-ups	TRUE	-	Uint8
5-25	Terminal X46/11 Digital Input	[0] No operation	All set-ups	TRUE	-	Uint8
5-26	Terminal X46/13 Digital Input	[0] No operation	All set-ups	TRUE	-	Uint8
5-3* Digital Outputs						
5-30	Terminal 27 Digital Output	ExpressionLimit	All set-ups	TRUE	-	Uint8
5-31	Terminal 29 Digital Output	ExpressionLimit	All set-ups	TRUE	-	Uint8
5-32	Term X30/6 Digi Out (MCB 101)	ExpressionLimit	All set-ups	TRUE	-	Uint8
5-33	Term X30/7 Digi Out (MCB 101)	ExpressionLimit	All set-ups	TRUE	-	Uint8
5-4* Relays						
5-40	Function Relay	ExpressionLimit	All set-ups	TRUE	-	Uint8
5-41	On Delay, Relay	0.01 s	All set-ups	TRUE	-2	Uint16
5-42	Off Delay, Relay	0.01 s	All set-ups	TRUE	-2	Uint16
5-5* Pulse Input						
5-50	Term. 29 Low Frequency	100 Hz	All set-ups	TRUE	0	Uint32
5-51	Term. 29 High Frequency	100 Hz	All set-ups	TRUE	0	Uint32
5-52	Term. 29 Low Ref./Feedb. Value	0 ReferenceFeed- backUnit	All set-ups	TRUE	-3	Int32
5-53	Term. 29 High Ref./Feedb. Value	ExpressionLimit	All set-ups	TRUE	-3	Int32
5-54	Pulse Filter Time Constant #29	100 ms	All set-ups	FALSE	-3	Uint16
5-55	Term. 33 Low Frequency	100 Hz	All set-ups	TRUE	0	Uint32
5-56	Term. 33 High Frequency	100 Hz	All set-ups	TRUE	0	Uint32
5-57	Term. 33 Low Ref./Feedb. Value	0 ReferenceFeed- backUnit	All set-ups	TRUE	-3	Int32
5-58	Term. 33 High Ref./Feedb. Value	ExpressionLimit	All set-ups	TRUE	-3	Int32

5-59	Pulse Filter Time Constant #33	100 ms	All set-ups	FALSE	-3	Uint16
5-6* Pulse Output						
5-60	Terminal 27 Pulse Output Variable	ExpressionLimit	All set-ups	TRUE	-	Uint8
5-62	Pulse Output Max Freq #27	ExpressionLimit	All set-ups	TRUE	0	Uint32
5-63	Terminal 29 Pulse Output Variable	ExpressionLimit	All set-ups	TRUE	-	Uint8
5-65	Pulse Output Max Freq #29	ExpressionLimit	All set-ups	TRUE	0	Uint32
5-66	Terminal X30/6 Pulse Output Variable	ExpressionLimit	All set-ups	TRUE	-	Uint8
5-68	Pulse Output Max Freq #X30/6	ExpressionLimit	All set-ups	TRUE	0	Uint32
5-7* 24V Encoder Input						
5-70	Term 32/33 Pulses Per Revolution	1024 N/A	All set-ups	FALSE	0	Uint16
5-71	Term 32/33 Encoder Direction	[0] Clockwise	All set-ups	FALSE	-	Uint8
5-72	Term 32/33 Encoder Type	[0] Quadrature A/B Format	All set-ups	FALSE	-	Uint8
5-8* I/O Options						
5-80	AHF Cap Reconnect Delay	25 s	2 set-ups	TRUE	0	Uint16
5-9* Bus Controlled						
5-90	Digital & Relay Bus Control	0 N/A	All set-ups	TRUE	0	Uint32
5-93	Pulse Out #27 Bus Control	0 %	All set-ups	TRUE	-2	N2
5-94	Pulse Out #27 Timeout Preset	0 %	1 set-up	TRUE	-2	Uint16
5-95	Pulse Out #29 Bus Control	0 %	All set-ups	TRUE	-2	N2
5-96	Pulse Out #29 Timeout Preset	0 %	1 set-up	TRUE	-2	Uint16
5-97	Pulse Out #X30/6 Bus Control	0 %	All set-ups	TRUE	-2	N2
5-98	Pulse Out #X30/6 Timeout Preset	0 %	1 set-up	TRUE	-2	Uint16

5.3.7 6-** Analog In/Out

Parameter #	Parameter description	Default value	4 set-up	Change during operation	Conversion index	Type
6-0* Analog I/O Mode						
6-00	Live Zero Timeout Time	10 s	All set-ups	TRUE	0	Uint8
6-01	Live Zero Timeout Function	[0] Off	All set-ups	TRUE	-	Uint8
6-1* Analog Input 1						
6-10	Terminal 53 Low Voltage	0.07 V	All set-ups	TRUE	-2	Int16
6-11	Terminal 53 High Voltage	10 V	All set-ups	TRUE	-2	Int16
6-12	Terminal 53 Low Current	0.14 mA	All set-ups	TRUE	-5	Int16
6-13	Terminal 53 High Current	20 mA	All set-ups	TRUE	-5	Int16
6-14	Terminal 53 Low Ref./Feedb. Value	0 ReferenceFeed-backUnit	All set-ups	TRUE	-3	Int32
6-15	Terminal 53 High Ref./Feedb. Value	ExpressionLimit	All set-ups	TRUE	-3	Int32
6-16	Terminal 53 Filter Time Constant	0.001 s	All set-ups	TRUE	-3	Uint16
6-2* Analog Input 2						
6-20	Terminal 54 Low Voltage	0.07 V	All set-ups	TRUE	-2	Int16
6-21	Terminal 54 High Voltage	10 V	All set-ups	TRUE	-2	Int16
6-22	Terminal 54 Low Current	0.14 mA	All set-ups	TRUE	-5	Int16
6-23	Terminal 54 High Current	20 mA	All set-ups	TRUE	-5	Int16
6-24	Terminal 54 Low Ref./Feedb. Value	0 ReferenceFeed-backUnit	All set-ups	TRUE	-3	Int32
6-25	Terminal 54 High Ref./Feedb. Value	ExpressionLimit	All set-ups	TRUE	-3	Int32
6-26	Terminal 54 Filter Time Constant	0.001 s	All set-ups	TRUE	-3	Uint16
6-3* Analog Input 3						
6-30	Terminal X30/11 Low Voltage	0.07 V	All set-ups	TRUE	-2	Int16
6-31	Terminal X30/11 High Voltage	10 V	All set-ups	TRUE	-2	Int16
6-34	Term. X30/11 Low Ref./Feedb. Value	0 ReferenceFeed-backUnit	All set-ups	TRUE	-3	Int32

6-35	Term. X30/11 High Ref./Feedb. Value	ExpressionLimit	All set-ups	TRUE	-3	Int32
6-36	Term. X30/11 Filter Time Constant	0.001 s	All set-ups	TRUE	-3	UInt16
6-4* Analog Input 4						
6-40	Terminal X30/12 Low Voltage	0.07 V	All set-ups	TRUE	-2	Int16
6-41	Terminal X30/12 High Voltage	10 V	All set-ups	TRUE	-2	Int16
6-44	Term. X30/12 Low Ref./Feedb. Value	0 ReferenceFeed-backUnit	All set-ups	TRUE	-3	Int32
6-45	Term. X30/12 High Ref./Feedb. Value	ExpressionLimit	All set-ups	TRUE	-3	Int32
6-46	Term. X30/12 Filter Time Constant	0.001 s	All set-ups	TRUE	-3	UInt16
6-5* Analog Output 1						
6-50	Terminal 42 Output	ExpressionLimit	All set-ups	TRUE	-	UInt8
6-51	Terminal 42 Output Min Scale	0 %	All set-ups	TRUE	-2	Int16
6-52	Terminal 42 Output Max Scale	100 %	All set-ups	TRUE	-2	Int16
6-53	Term 42 Output Bus Ctrl	0 %	All set-ups	TRUE	-2	N2
6-54	Terminal 42 Output Timeout Preset	0 %	1 set-up	TRUE	-2	UInt16
6-55	Analog Output Filter	[0] Off	1 set-up	TRUE	-	UInt8
6-6* Analog Output 2						
6-60	Terminal X30/8 Output	ExpressionLimit	All set-ups	TRUE	-	UInt8
6-61	Terminal X30/8 Min. Scale	0 %	All set-ups	TRUE	-2	Int16
6-62	Terminal X30/8 Max. Scale	100 %	All set-ups	TRUE	-2	Int16
6-63	Terminal X30/8 Bus Control	0 %	All set-ups	TRUE	-2	N2
6-64	Terminal X30/8 Output Timeout Preset	0 %	1 set-up	TRUE	-2	UInt16
6-7* Analog Output 3						
6-70	Terminal X45/1 Output	ExpressionLimit	All set-ups	TRUE	-	UInt8
6-71	Terminal X45/1 Min. Scale	0 %	All set-ups	TRUE	-2	Int16
6-72	Terminal X45/1 Max. Scale	100 %	All set-ups	TRUE	-2	Int16
6-73	Terminal X45/1 Bus Control	0 %	All set-ups	TRUE	-2	N2
6-74	Terminal X45/1 Output Timeout Preset	0 %	1 set-up	TRUE	-2	UInt16
6-8* Analog Output 4						
6-80	Terminal X45/3 Output	ExpressionLimit	All set-ups	TRUE	-	UInt8
6-81	Terminal X45/3 Min. Scale	0 %	All set-ups	TRUE	-2	Int16
6-82	Terminal X45/3 Max. Scale	100 %	All set-ups	TRUE	-2	Int16
6-83	Terminal X45/3 Bus Control	0 %	All set-ups	TRUE	-2	N2
6-84	Terminal X45/3 Output Timeout Preset	0 %	1 set-up	TRUE	-2	UInt16

5.3.8 7-** Controllers

Parameter #	Parameter description	Default value	4 set-up	Change during operation	Conversion index	Type
7-0* Speed PID Ctrl.						
7-00	Speed PID Feedback Source	ExpressionLimit	All set-ups	FALSE	-	UInt8
7-01	Speed PID Droop	0 RPM	All set-ups	TRUE	67	UInt16
7-02	Speed PID Proportional Gain	ExpressionLimit	All set-ups	TRUE	-3	UInt16
7-03	Speed PID Integral Time	ExpressionLimit	All set-ups	TRUE	-4	UInt32
7-04	Speed PID Differentiation Time	ExpressionLimit	All set-ups	TRUE	-4	UInt16
7-05	Speed PID Diff. Gain Limit	5 N/A	All set-ups	TRUE	-1	UInt16
7-06	Speed PID Lowpass Filter Time	ExpressionLimit	All set-ups	TRUE	-4	UInt16
7-07	Speed PID Feedback Gear Ratio	1 N/A	All set-ups	FALSE	-4	UInt32
7-08	Speed PID Accel. Feed Forward Factor	0 %	All set-ups	TRUE	0	UInt16
7-09	Speed PID Error Correction w/ Ramp	300 RPM	All set-ups	TRUE	67	UInt32

7-1* Torque PI Ctrl.						
7-10	Torque PI Feedback Source	[0] Controller Off	All set-ups	TRUE	-	Uint8
7-12	Torque PI Proportional Gain	100 %	All set-ups	TRUE	0	Uint16
7-13	Torque PI Integration Time	0.020 s	All set-ups	TRUE	-3	Uint16
7-16	Torque PI Lowpass Filter Time	5 ms	All set-ups	TRUE	-4	Uint16
7-18	Torque PI Feed Forward Factor	0 %	All set-ups	TRUE	0	Uint16
7-19	Current Controller Rise Time	ExpressionLimit	All set-ups	TRUE	0	Uint16
7-2* Process Ctrl. Feedb						
7-20	Process CL Feedback 1 Resource	[0] No function	All set-ups	TRUE	-	Uint8
7-22	Process CL Feedback 2 Resource	[0] No function	All set-ups	TRUE	-	Uint8
7-3* Process PID Ctrl.						
7-30	Process PID Normal/ Inverse Control	[0] Normal	All set-ups	TRUE	-	Uint8
7-31	Process PID Anti Windup	[1] On	All set-ups	TRUE	-	Uint8
7-32	Process PID Start Speed	0 RPM	All set-ups	TRUE	67	Uint16
7-33	Process PID Proportional Gain	0.01 N/A	All set-ups	TRUE	-2	Uint16
7-34	Process PID Integral Time	10000 s	All set-ups	TRUE	-2	Uint32
7-35	Process PID Differentiation Time	0 s	All set-ups	TRUE	-2	Uint16
7-36	Process PID Diff. Gain Limit	5 N/A	All set-ups	TRUE	-1	Uint16
7-38	Process PID Feed Forward Factor	0 %	All set-ups	TRUE	0	Uint16
7-39	On Reference Bandwidth	5 %	All set-ups	TRUE	0	Uint8
7-9* Position PI Ctrl.						
7-90	Position PI Feedback Source	[0] Motor feedb. P1-02	All set-ups	TRUE	-	Uint8
7-92	Position PI Proportional Gain	0.0150 N/A	All set-ups	TRUE	-4	Uint32
7-93	Position PI Integral Time	20000.0 ms	All set-ups	TRUE	-4	Uint32
7-94	Position PI Feedback Scale Numerator	1 N/A	All set-ups	FALSE	0	Int32
7-95	Position PI Feedback Scale Denominator	1 N/A	All set-ups	FALSE	0	Int32
7-97	Position PI Maximum Speed Above Master	100 RPM	All set-ups	TRUE	67	Uint16
7-98	Position PI Feed Forward Factor	98 %	All set-ups	TRUE	0	Uint16
7-99	Position PI Minimum Ramp Time	0.01 s	All set-ups	TRUE	-3	Uint32

5.3.9 8-** Comm. and Options

Parameter #	Parameter description	Default value	4 set-up	Change during operation	Conversion index	Type
8-0* General Settings						
8-01	Control Site	[0] Digital and ctrl.word	All set-ups	TRUE	-	Uint8
8-02	Control Word Source	ExpressionLimit	All set-ups	TRUE	-	Uint8
8-03	Control Word Timeout Time	1 s	1 set-up	TRUE	-1	Uint32
8-04	Control Word Timeout Function	ExpressionLimit	1 set-up	TRUE	-	Uint8
8-05	End-of-Timeout Function	[1] Resume set-up	1 set-up	TRUE	-	Uint8
8-06	Reset Control Word Timeout	[0] Do not reset	All set-ups	TRUE	-	Uint8
8-07	Diagnosis Trigger	[0] Disable	2 set-ups	TRUE	-	Uint8
8-08	Readout Filtering	ExpressionLimit	All set-ups	TRUE	-	Uint8
8-1* Ctrl. Word Settings						
8-10	Control Word Profile	ExpressionLimit	All set-ups	TRUE	-	Uint8
8-13	Configurable Status Word STW	[1] Profile Default	All set-ups	TRUE	-	Uint8
8-14	Configurable Control Word CTW	[1] Profile default	All set-ups	TRUE	-	Uint8
8-17	Configurable Alarm and Warningword	[0] Off	All set-ups	TRUE	-	Uint16

8-19	Product Code	ExpressionLimit	1 set-up	TRUE	0	Uint32
8-3* FC Port Settings						
8-30	Protocol	[0] FC	1 set-up	TRUE	-	Uint8
8-31	Address	1 N/A	1 set-up	TRUE	0	Uint8
8-32	FC Port Baud Rate	ExpressionLimit	1 set-up	TRUE	-	Uint8
8-33	Parity / Stop Bits	[0] Even Parity, 1 Stop Bit	1 set-up	TRUE	-	Uint8
8-34	Estimated cycle time	0 ms	2 set-ups	TRUE	-3	Uint32
8-35	Minimum Response Delay	10 ms	1 set-up	TRUE	-3	Uint16
8-36	Max Response Delay	ExpressionLimit	1 set-up	TRUE	-3	Uint16
8-37	Max Inter-Char Delay	ExpressionLimit	1 set-up	TRUE	-5	Uint16
8-4* FC MC protocol set						
8-40	Telegram Selection	[1] Standard telegram 1	2 set-ups	TRUE	-	Uint8
8-41	Parameters for Signals	0	All set-ups	FALSE	-	Uint16
8-42	PCD Write Configuration	ExpressionLimit	2 set-ups	TRUE	0	Uint16
8-43	PCD Read Configuration	ExpressionLimit	2 set-ups	TRUE	0	Uint16
8-5* Digital/Bus						
8-50	Coasting Select	[3] Logic OR	All set-ups	TRUE	-	Uint8
8-51	Quick Stop Select	[3] Logic OR	All set-ups	TRUE	-	Uint8
8-52	DC Brake Select	ExpressionLimit	All set-ups	TRUE	-	Uint8
8-53	Start Select	[3] Logic OR	All set-ups	TRUE	-	Uint8
8-54	Reversing Select	[3] Logic OR	All set-ups	TRUE	-	Uint8
8-55	Set-up Select	[3] Logic OR	All set-ups	TRUE	-	Uint8
8-56	Preset Reference Select	[3] Logic OR	All set-ups	TRUE	-	Uint8
8-57	Profdrive OFF2 Select	[3] Logic OR	All set-ups	TRUE	-	Uint8
8-58	Profdrive OFF3 Select	[3] Logic OR	All set-ups	TRUE	-	Uint8
8-8* FC Port Diagnostics						
8-80	Bus Message Count	0 N/A	All set-ups	TRUE	0	Uint32
8-81	Bus Error Count	0 N/A	All set-ups	TRUE	0	Uint32
8-82	Slave Messages Rcvd	0 N/A	All set-ups	TRUE	0	Uint32
8-83	Slave Error Count	0 N/A	All set-ups	TRUE	0	Uint32
8-9* Bus Jog						
8-90	Bus Jog 1 Speed	100 RPM	All set-ups	TRUE	67	Uint16
8-91	Bus Jog 2 Speed	ExpressionLimit	All set-ups	TRUE	67	Uint16

5.3.10 9-** Profibus

Parameter #	Parameter description	Default value	4 set-up	Change during operation	Conversion index	Type
9-00	Setpoint	0 N/A	All set-ups	TRUE	0	Uint16
9-07	Actual Value	0 N/A	All set-ups	FALSE	0	Uint16
9-15	PCD Write Configuration	ExpressionLimit	1 set-up	TRUE	-	Uint16
9-16	PCD Read Configuration	ExpressionLimit	2 set-ups	TRUE	-	Uint16
9-18	Node Address	126 N/A	1 set-up	TRUE	0	Uint8
9-19	Drive Unit System Number	1034 N/A	All set-ups	TRUE	0	Uint16
9-22	Telegram Selection	[100] None	1 set-up	TRUE	-	Uint8
9-23	Parameters for Signals	0	All set-ups	TRUE	-	Uint16
9-27	Parameter Edit	[1] Enabled	2 set-ups	FALSE	-	Uint16
9-28	Process Control	[1] Enable cyclic master	2 set-ups	FALSE	-	Uint8
9-44	Fault Message Counter	0 N/A	All set-ups	TRUE	0	Uint16
9-45	Fault Code	0 N/A	All set-ups	TRUE	0	Uint16
9-47	Fault Number	0 N/A	All set-ups	TRUE	0	Uint16

9-52	Fault Situation Counter	0 N/A	All set-ups	TRUE	0	Uint16
9-53	Profibus Warning Word	0 N/A	All set-ups	TRUE	0	V2
9-63	Actual Baud Rate	[255] No baudrate found	All set-ups	TRUE	-	Uint8
9-64	Device Identification	0 N/A	All set-ups	TRUE	0	Uint16
9-65	Profile Number	0 N/A	All set-ups	TRUE	0	OctStr[2]
9-67	Control Word 1	0 N/A	All set-ups	TRUE	0	V2
9-68	Status Word 1	0 N/A	All set-ups	TRUE	0	V2
9-70	Edit Set-up	[1] Set-up 1	All set-ups	TRUE	-	Uint8
9-71	Profibus Save Data Values	[0] Off	All set-ups	TRUE	-	Uint8
9-72	ProfibusDriveReset	[0] No action	1 set-up	FALSE	-	Uint8
9-75	DO Identification	0 N/A	All set-ups	TRUE	0	Uint16
9-80	Defined Parameters (1)	0 N/A	All set-ups	FALSE	0	Uint16
9-81	Defined Parameters (2)	0 N/A	All set-ups	FALSE	0	Uint16
9-82	Defined Parameters (3)	0 N/A	All set-ups	FALSE	0	Uint16
9-83	Defined Parameters (4)	0 N/A	All set-ups	FALSE	0	Uint16
9-84	Defined Parameters (5)	0 N/A	All set-ups	FALSE	0	Uint16
9-85	Defined Parameters (6)	0 N/A	All set-ups	FALSE	0	Uint16
9-90	Changed Parameters (1)	0 N/A	All set-ups	FALSE	0	Uint16
9-91	Changed Parameters (2)	0 N/A	All set-ups	FALSE	0	Uint16
9-92	Changed Parameters (3)	0 N/A	All set-ups	FALSE	0	Uint16
9-93	Changed Parameters (4)	0 N/A	All set-ups	FALSE	0	Uint16
9-94	Changed Parameters (5)	0 N/A	All set-ups	FALSE	0	Uint16
9-99	Profibus Revision Counter	0 N/A	All set-ups	TRUE	0	Uint16

5.3.11 13-** Smart Logic

Parameter #	Parameter description	Default value	4 set-up	Change during operation	Conversion index	Type
13-0* SLC Settings						
13-00	SL Controller Mode	ExpressionLimit	2 set-ups	TRUE	-	Uint8
13-01	Start Event	ExpressionLimit	2 set-ups	TRUE	-	Uint8
13-02	Stop Event	ExpressionLimit	2 set-ups	TRUE	-	Uint8
13-03	Reset SLC	[0] Do not reset SLC	All set-ups	TRUE	-	Uint8
13-1* Comparators						
13-10	Comparator Operand	ExpressionLimit	2 set-ups	TRUE	-	Uint8
13-11	Comparator Operator	ExpressionLimit	2 set-ups	TRUE	-	Uint8
13-12	Comparator Value	ExpressionLimit	2 set-ups	TRUE	-3	Int32
13-1* RS Flip Flops						
13-15	RS-FF Operand S	ExpressionLimit	2 set-ups	TRUE	-	Uint8
13-16	RS-FF Operand R	ExpressionLimit	2 set-ups	TRUE	-	Uint8
13-2* Timers						
13-20	SL Controller Timer	ExpressionLimit	1 set-up	TRUE	-3	TimD
13-4* Logic Rules						
13-40	Logic Rule Boolean 1	ExpressionLimit	2 set-ups	TRUE	-	Uint8
13-41	Logic Rule Operator 1	ExpressionLimit	2 set-ups	TRUE	-	Uint8
13-42	Logic Rule Boolean 2	ExpressionLimit	2 set-ups	TRUE	-	Uint8
13-43	Logic Rule Operator 2	ExpressionLimit	2 set-ups	TRUE	-	Uint8
13-44	Logic Rule Boolean 3	ExpressionLimit	2 set-ups	TRUE	-	Uint8
13-5* States						
13-51	SL Controller Event	ExpressionLimit	2 set-ups	TRUE	-	Uint8
13-52	SL Controller Action	ExpressionLimit	2 set-ups	TRUE	-	Uint8

5.3.12 14-** Special Functions

5

Parameter #	Parameter description	Default value	4 set-up	Change during operation	Conversion index	Type
14-0* Inverter Switching						
14-00	Switching Pattern	[1] SFAVM	All set-ups	TRUE	-	Uint8
14-01	Switching Frequency	ExpressionLimit	All set-ups	TRUE	-	Uint8
14-03	Overmodulation	[1] On	All set-ups	FALSE	-	Uint8
14-04	PWM Random	[0] Off	All set-ups	TRUE	-	Uint8
14-06	Dead Time Compensation	[1] On	All set-ups	TRUE	-	Uint8
14-1* Mains On/Off						
14-10	Mains Failure	[0] No function	All set-ups	TRUE	-	Uint8
14-11	Mains Voltage at Mains Fault	ExpressionLimit	All set-ups	TRUE	0	Uint16
14-12	Function at Mains Imbalance	[0] Trip	All set-ups	TRUE	-	Uint8
14-14	Kin. Backup Time Out	60 s	All set-ups	TRUE	0	Uint8
14-15	Kin. Backup Trip Recovery Level	ExpressionLimit	All set-ups	TRUE	-3	Uint32
14-16	Kin. Backup Gain	100 %	All set-ups	TRUE	0	Uint32
14-2* Trip Reset						
14-20	Reset Mode	[0] Manual reset	All set-ups	TRUE	-	Uint8
14-21	Automatic Restart Time	ExpressionLimit	All set-ups	TRUE	0	Uint16
14-22	Operation Mode	[0] Normal operation	All set-ups	TRUE	-	Uint8
14-23	Typecode Setting	ExpressionLimit	2 set-ups	FALSE	-	Uint8
14-24	Trip Delay at Current Limit	60 s	All set-ups	TRUE	0	Uint8
14-25	Trip Delay at Torque Limit	60 s	All set-ups	TRUE	0	Uint8
14-26	Trip Delay at Inverter Fault	ExpressionLimit	All set-ups	TRUE	0	Uint8
14-28	Production Settings	[0] No action	All set-ups	TRUE	-	Uint8
14-29	Service Code	0 N/A	All set-ups	TRUE	0	Int32
14-3* Current Limit Ctrl.						
14-30	Current Lim Ctrl, Proportional Gain	100 %	All set-ups	FALSE	0	Uint16
14-31	Current Lim Ctrl, Integration Time	ExpressionLimit	All set-ups	FALSE	-3	Uint16
14-32	Current Lim Ctrl, Filter Time	ExpressionLimit	All set-ups	TRUE	-4	Uint16
14-35	Stall Protection	[1] Enabled	All set-ups	FALSE	-	Uint8
14-36	Fieldweakening Function	[0] Auto	All set-ups	TRUE	-	Uint8
14-4* Energy Optimising						
14-40	VT Level	66 %	All set-ups	FALSE	0	Uint8
14-41	AEO Minimum Magnetisation	ExpressionLimit	All set-ups	TRUE	0	Uint8
14-42	Minimum AEO Frequency	ExpressionLimit	All set-ups	TRUE	0	Uint8
14-43	Motor Cosphi	ExpressionLimit	All set-ups	TRUE	-2	Uint16
14-5* Environment						
14-50	RFI Filter	[1] On	1 set-up	FALSE	-	Uint8
14-51	DC Link Compensation	ExpressionLimit	All set-ups	TRUE	-	Uint8
14-52	Fan Control	[0] Auto	All set-ups	TRUE	-	Uint8
14-53	Fan Monitor	ExpressionLimit	All set-ups	TRUE	-	Uint8
14-55	Output Filter	[0] No Filter	All set-ups	FALSE	-	Uint8
14-56	Capacitance Output Filter	ExpressionLimit	All set-ups	FALSE	-7	Uint16
14-57	Inductance Output Filter	ExpressionLimit	All set-ups	FALSE	-6	Uint16
14-59	Actual Number of Inverter Units	ExpressionLimit	1 set-up	FALSE	0	Uint8
14-7* Compatibility						
14-72	Legacy Alarm Word	0 N/A	All set-ups	FALSE	0	Uint32
14-73	Legacy Warning Word	0 N/A	All set-ups	FALSE	0	Uint32
14-74	Leg. Ext. Status Word	0 N/A	All set-ups	FALSE	0	Uint32
14-8* Options						
14-80	Option Supplied by External 24VDC	[1] Yes	2 set-ups	FALSE	-	Uint8

14-88	Option Data Storage	0 N/A	2 set-ups	TRUE	0	Uint16
14-89	Option Detection	[0] Protect Option Config.	1 set-up	TRUE	-	Uint8
14-9* Fault Settings						
14-90	Fault Level	ExpressionLimit	1 set-up	TRUE	-	Uint8

5.3.13 15-** Drive Information

Parameter #	Parameter description	Default value	4 set-up	Change during operation	Conversion index	Type
15-0* Operating Data						
15-00	Operating hours	0 h	All set-ups	FALSE	74	Uint32
15-01	Running Hours	0 h	All set-ups	FALSE	74	Uint32
15-02	kWh Counter	0 kWh	All set-ups	FALSE	75	Uint32
15-03	Power Up's	0 N/A	All set-ups	FALSE	0	Uint32
15-04	Over Temp's	0 N/A	All set-ups	FALSE	0	Uint16
15-05	Over Volt's	0 N/A	All set-ups	FALSE	0	Uint16
15-06	Reset kWh Counter	[0] Do not reset	All set-ups	TRUE	-	Uint8
15-07	Reset Running Hours Counter	[0] Do not reset	All set-ups	TRUE	-	Uint8
15-1* Data Log Settings						
15-10	Logging Source	0	2 set-ups	TRUE	-	Uint16
15-11	Logging Interval	ExpressionLimit	2 set-ups	TRUE	-3	TimD
15-12	Trigger Event	[0] False	1 set-up	TRUE	-	Uint8
15-13	Logging Mode	[0] Log always	2 set-ups	TRUE	-	Uint8
15-14	Samples Before Trigger	50 N/A	2 set-ups	TRUE	0	Uint8
15-2* Historic Log						
15-20	Historic Log: Event	0 N/A	All set-ups	FALSE	0	Uint8
15-21	Historic Log: Value	0 N/A	All set-ups	FALSE	0	Uint32
15-22	Historic Log: Time	0 ms	All set-ups	FALSE	-3	Uint32
15-3* Fault Log						
15-30	Fault Log: Error Code	0 N/A	All set-ups	FALSE	0	Uint16
15-31	Fault Log: Value	0 N/A	All set-ups	FALSE	0	Int16
15-32	Fault Log: Time	0 s	All set-ups	FALSE	0	Uint32
15-4* Drive Identification						
15-40	FC Type	0 N/A	All set-ups	FALSE	0	VisStr[6]
15-41	Power Section	0 N/A	All set-ups	FALSE	0	VisStr[20]
15-42	Voltage	0 N/A	All set-ups	FALSE	0	VisStr[20]
15-43	Software Version	0 N/A	All set-ups	FALSE	0	VisStr[5]
15-44	Ordered Typecode String	0 N/A	All set-ups	FALSE	0	VisStr[40]
15-45	Actual Typecode String	0 N/A	All set-ups	FALSE	0	VisStr[40]
15-46	Frequency Converter Ordering No	0 N/A	All set-ups	FALSE	0	VisStr[8]
15-47	Power Card Ordering No	0 N/A	All set-ups	FALSE	0	VisStr[8]
15-48	LCP Id No	0 N/A	All set-ups	FALSE	0	VisStr[20]
15-49	SW ID Control Card	0 N/A	All set-ups	FALSE	0	VisStr[20]
15-50	SW ID Power Card	0 N/A	All set-ups	FALSE	0	VisStr[20]
15-51	Frequency Converter Serial Number	0 N/A	All set-ups	FALSE	0	VisStr[10]
15-53	Power Card Serial Number	0 N/A	All set-ups	FALSE	0	VisStr[19]
15-58	Smart Setup Filename	ExpressionLimit	All set-ups	TRUE	0	VisStr[20]
15-59	CSIV Filename	ExpressionLimit	1 set-up	FALSE	0	VisStr[16]
15-6* Option Ident						
15-60	Option Mounted	0 N/A	All set-ups	FALSE	0	VisStr[30]
15-61	Option SW Version	0 N/A	All set-ups	FALSE	0	VisStr[20]
15-62	Option Ordering No	0 N/A	All set-ups	FALSE	0	VisStr[8]
15-63	Option Serial No	0 N/A	All set-ups	FALSE	0	VisStr[18]

15-70	Option in Slot A	0 N/A	All set-ups	FALSE	0	VisStr[30]
15-71	Slot A Option SW Version	0 N/A	All set-ups	FALSE	0	VisStr[20]
15-72	Option in Slot B	0 N/A	All set-ups	FALSE	0	VisStr[30]
15-73	Slot B Option SW Version	0 N/A	All set-ups	FALSE	0	VisStr[20]
15-74	Option in Slot C0/E0	0 N/A	All set-ups	FALSE	0	VisStr[30]
15-75	Slot C0/E0 Option SW Version	0 N/A	All set-ups	FALSE	0	VisStr[20]
15-76	Option in Slot C1/E1	0 N/A	All set-ups	FALSE	0	VisStr[30]
15-77	Slot C1/E1 Option SW Version	0 N/A	All set-ups	FALSE	0	VisStr[20]
15-8* Operating Data II						
15-80	Fan Running Hours	0 h	All set-ups	TRUE	74	Uint32
15-81	Preset Fan Running Hours	0 h	All set-ups	TRUE	74	Uint32
15-89	Configuration Change Counter	0 N/A	All set-ups	FALSE	0	Uint16
15-9* Parameter Info						
15-92	Defined Parameters	0 N/A	All set-ups	FALSE	0	Uint16
15-93	Modified Parameters	0 N/A	All set-ups	FALSE	0	Uint16
15-98	Drive Identification	0 N/A	All set-ups	FALSE	0	VisStr[40]
15-99	Parameter Metadata	0 N/A	All set-ups	FALSE	0	Uint16

5.3.14 16-** Data Readouts

Parameter #	Parameter description	Default value	4 set-up	Change during operation	Conversion index	Type
16-0* General Status						
16-00	Control Word	0 N/A	All set-ups	FALSE	0	V2
16-01	Reference [Unit]	0 ReferenceFeed-backUnit	All set-ups	FALSE	-3	Int32
16-02	Reference %	0 %	All set-ups	FALSE	-1	Int16
16-03	Status Word	0 N/A	All set-ups	FALSE	0	V2
16-05	Main Actual Value [%]	0 %	All set-ups	FALSE	-2	N2
16-06	Actual Position	0 CustomReadoutUnit2	All set-ups	FALSE	0	Int32
16-07	Target Position	0 CustomReadoutUnit2	All set-ups	FALSE	0	Int32
16-08	Position Error	0 CustomReadoutUnit2	All set-ups	FALSE	0	Int32
16-09	Custom Readout	0 CustomReadoutUnit	All set-ups	FALSE	-2	Int32
16-1* Motor Status						
16-10	Power [kW]	0 kW	All set-ups	FALSE	1	Int32
16-11	Power [hp]	0 hp	All set-ups	FALSE	-2	Int32
16-12	Motor Voltage	0 V	All set-ups	FALSE	-1	Uint16
16-13	Frequency	0 Hz	All set-ups	FALSE	-1	Uint16
16-14	Motor current	0 A	All set-ups	FALSE	-2	Int32
16-15	Frequency [%]	0 %	All set-ups	FALSE	-2	N2
16-16	Torque [Nm]	0 Nm	All set-ups	FALSE	-1	Int16
16-17	Speed [RPM]	0 RPM	All set-ups	FALSE	67	Int32
16-18	Motor Thermal	0 %	All set-ups	FALSE	0	Uint8
16-19	KTY sensor temperature	0 °C	All set-ups	FALSE	100	Int16
16-20	Motor Angle	0 N/A	All set-ups	TRUE	0	Uint16
16-21	Torque [%] High Res.	0 %	All set-ups	FALSE	-1	Int16
16-22	Torque [%]	0 %	All set-ups	FALSE	0	Int16
16-23	Motor Shaft Power [kW]	0 kW	All set-ups	TRUE	1	Int32
16-24	Calibrated Stator Resistance	0.0000 Ohm	All set-ups	TRUE	-4	Uint32
16-25	Torque [Nm] High	0 Nm	All set-ups	FALSE	-1	Int32

16-3* Drive Status						
16-30	DC Link Voltage	0 V	All set-ups	FALSE	0	Uint16
16-32	Brake Energy /s	0 kW	All set-ups	FALSE	0	Uint32
16-33	Brake Energy Average	0 kW	All set-ups	FALSE	0	Uint32
16-34	Heatsink Temp.	0 °C	All set-ups	FALSE	100	Uint8
16-35	Inverter Thermal	0 %	All set-ups	FALSE	0	Uint8
16-36	Inv. Nom. Current	ExpressionLimit	All set-ups	FALSE	-2	Uint32
16-37	Inv. Max. Current	ExpressionLimit	All set-ups	FALSE	-2	Uint32
16-38	SL Controller State	0 N/A	All set-ups	FALSE	0	Uint8
16-39	Control Card Temp.	0 °C	All set-ups	FALSE	100	Uint8
16-40	Logging Buffer Full	[0] No	All set-ups	TRUE	-	Uint8
16-41	LCP Bottom Statusline	0 N/A	All set-ups	TRUE	0	VisStr[50]
16-44	Speed Error [RPM]	0 RPM	All set-ups	FALSE	67	Int32
16-45	Motor Phase U Current	0 A	All set-ups	TRUE	-2	Int32
16-46	Motor Phase V Current	0 A	All set-ups	TRUE	-2	Int32
16-47	Motor Phase W Current	0 A	All set-ups	TRUE	-2	Int32
16-48	Speed Ref. After Ramp [RPM]	0 RPM	All set-ups	FALSE	67	Int32
16-49	Current Fault Source	0 N/A	All set-ups	TRUE	0	Uint8
16-5* Ref. & Feedb.						
16-50	External Reference	0 N/A	All set-ups	FALSE	-1	Int16
16-51	Pulse Reference	0 N/A	All set-ups	FALSE	-1	Int16
16-52	Feedback[Unit]	0 ReferenceFeed-backUnit	All set-ups	FALSE	-3	Int32
16-53	Digi Pot Reference	0 N/A	All set-ups	FALSE	-2	Int16
16-57	Feedback [RPM]	0 RPM	All set-ups	FALSE	67	Int32
16-6* Inputs & Outputs						
16-60	Digital Input	0 N/A	All set-ups	FALSE	0	Uint16
16-61	Terminal 53 Switch Setting	[0] Current	All set-ups	FALSE	-	Uint8
16-62	Analog Input 53	0 N/A	All set-ups	FALSE	-3	Int32
16-63	Terminal 54 Switch Setting	[0] Current	All set-ups	FALSE	-	Uint8
16-64	Analog Input 54	0 N/A	All set-ups	FALSE	-3	Int32
16-65	Analog Output 42 [mA]	0 N/A	All set-ups	FALSE	-3	Int16
16-66	Digital Output [bin]	0 N/A	All set-ups	FALSE	0	Int16
16-67	Freq. Input #29 [Hz]	0 N/A	All set-ups	FALSE	0	Int32
16-68	Freq. Input #33 [Hz]	0 N/A	All set-ups	FALSE	0	Int32
16-69	Pulse Output #27 [Hz]	0 N/A	All set-ups	FALSE	0	Int32
16-70	Pulse Output #29 [Hz]	0 N/A	All set-ups	FALSE	0	Int32
16-71	Relay Output [bin]	0 N/A	All set-ups	FALSE	0	Int16
16-72	Counter A	0 N/A	All set-ups	TRUE	0	Int32
16-73	Counter B	0 N/A	All set-ups	TRUE	0	Int32
16-74	Prec. Stop Counter	0 N/A	All set-ups	TRUE	0	Uint32
16-75	Analog In X30/11	0 N/A	All set-ups	FALSE	-3	Int32
16-76	Analog In X30/12	0 N/A	All set-ups	FALSE	-3	Int32
16-77	Analog Out X30/8 [mA]	0 N/A	All set-ups	FALSE	-3	Int16
16-78	Analog Out X45/1 [mA]	0 N/A	All set-ups	FALSE	-3	Int16
16-79	Analog Out X45/3 [mA]	0 N/A	All set-ups	FALSE	-3	Int16
16-8* Fieldbus & FC Port						
16-80	Fieldbus CTW 1	0 N/A	All set-ups	FALSE	0	V2
16-82	Fieldbus REF 1	0 N/A	All set-ups	FALSE	0	N2
16-83	Fieldbus REF 2	0 CustomRea-doutUnit2	1 set-up	TRUE	0	Int32
16-84	Comm. Option STW	0 N/A	All set-ups	FALSE	0	V2
16-85	FC Port CTW 1	0 N/A	All set-ups	FALSE	0	V2
16-86	FC Port REF 1	0 N/A	All set-ups	FALSE	0	N2

16-87	Bus Readout Alarm/Warning	0 N/A	All set-ups	FALSE	0	Uint16
16-89	Configurable Alarm/Warning Word	0 N/A	All set-ups	FALSE	0	Uint16
16-9* Diagnosis Readouts						
16-90	Alarm Word	0 N/A	All set-ups	FALSE	0	Uint32
16-91	Alarm Word 2	0 N/A	All set-ups	FALSE	0	Uint32
16-92	Warning Word	0 N/A	All set-ups	FALSE	0	Uint32
16-93	Warning Word 2	0 N/A	All set-ups	FALSE	0	Uint32
16-94	Ext. Status Word	0 N/A	All set-ups	FALSE	0	Uint32

5.3.15 17-** Motor Feedb.Option

5

Parameter #	Parameter description	Default value	4 set-up	Change during operation	Conversion index	Type
17-1* Inc. Enc. Interface						
17-10	Signal Type	[1] RS422 (5V TTL)	All set-ups	FALSE	-	Uint8
17-11	Resolution (PPR)	1024 N/A	All set-ups	FALSE	0	Uint16
17-2* Abs. Enc. Interface						
17-20	Protocol Selection	[0] None	All set-ups	FALSE	-	Uint8
17-21	Resolution (Positions/Rev)	ExpressionLimit	All set-ups	FALSE	0	Uint32
17-22	Multiturn Revolutions	1 N/A	All set-ups	FALSE	0	Uint32
17-24	SSI Data Length	13 N/A	All set-ups	FALSE	0	Uint8
17-25	Clock Rate	ExpressionLimit	All set-ups	FALSE	3	Uint16
17-26	SSI Data Format	[0] Gray code	All set-ups	FALSE	-	Uint8
17-34	HIPERFACE Baudrate	[4] 9600	All set-ups	FALSE	-	Uint8
17-5* Resolver Interface						
17-50	Poles	2 N/A	1 set-up	FALSE	0	Uint8
17-51	Input Voltage	7 V	1 set-up	FALSE	-1	Uint8
17-52	Input Frequency	10 kHz	1 set-up	FALSE	2	Uint8
17-53	Transformation Ratio	0.5 N/A	1 set-up	FALSE	-1	Uint8
17-56	Encoder Sim. Resolution	[0] Disabled	1 set-up	FALSE	-	Uint8
17-59	Resolver Interface	[0] Disabled	2 set-ups	FALSE	-	Uint8
17-6* Monitoring and App.						
17-60	Feedback Direction	[0] Clockwise	All set-ups	FALSE	-	Uint8
17-61	Feedback Signal Monitoring	[1] Warning	All set-ups	TRUE	-	Uint8
17-7* Position Scaling						
17-70	Position Unit	[0] pu	All set-ups	TRUE	-	Uint8
17-71	Position Unit Scale	0 N/A	All set-ups	FALSE	0	Int8
17-72	Position Unit Numerator	1024 N/A	All set-ups	FALSE	0	Int32
17-73	Position Unit Denominator	1 N/A	All set-ups	FALSE	0	Int32
17-74	Position Offset	0 CustomReadoutUnit2	All set-ups	FALSE	0	Int32
17-75	Position Recovery at Power-up	[0] Off	All set-ups	TRUE	-	Uint8
17-76	Position Axis Mode	[0] Linear Axis	All set-ups	TRUE	-	Uint8
17-8* Position Homing						
17-80	Homing Function	[0] No Homing	All set-ups	FALSE	-	Uint8
17-81	Home Sync Function	[0] 1st time after power	All set-ups	FALSE	-	Uint8
17-82	Home Position	0 N/A	All set-ups	FALSE	0	Int32
17-83	Homing Speed	150 RPM	All set-ups	TRUE	67	Uint16
17-84	Homing Torque Limit	160 %	All set-ups	TRUE	0	Uint16
17-85	Homing Timeout	60 s	All set-ups	TRUE	-1	Uint16
17-9* Position Config						
17-90	Absolute Position Mode	[0] Standard	All set-ups	FALSE	-	Uint8
17-91	Relative Position Mode	[0] Target Position	All set-ups	FALSE	-	Uint8

17-92	Position Control Selection	[0] No operation	All set-ups	FALSE	-	uint8
-------	----------------------------	------------------	-------------	-------	---	-------

5.3.16 30-** Special Features

Parameter #	Parameter description	Default value	4 set-up	Change during operation	Conversion index	Type
30-2* Adv. Start Adjust						
30-20	High Starting Torque Time [s]	ExpressionLimit	All set-ups	TRUE	-2	Uint16
30-21	High Starting Torque Current [%]	ExpressionLimit	All set-ups	TRUE	-1	Uint32
30-22	Locked Rotor Protection	ExpressionLimit	All set-ups	TRUE	-	Uint8
30-23	Locked Rotor Detection Time [s]	ExpressionLimit	All set-ups	TRUE	-2	Uint8
30-24	Locked Rotor Detection Speed Error [%]	25 %	All set-ups	TRUE	-1	Uint32
30-25	Light Load Delay [s]	0.000 s	All set-ups	TRUE	-3	Uint32
30-26	Light Load Current [%]	0 %	All set-ups	TRUE	0	Uint16
30-27	Light Load Speed [%]	0 %	All set-ups	TRUE	0	Uint16
30-8* Compatibility (I)						
30-80	d-axis Inductance (Ld)	ExpressionLimit	All set-ups	FALSE	-6	Int32
30-81	Brake Resistor (ohm)	ExpressionLimit	1 set-up	TRUE	-2	Uint32
30-83	Speed PID Proportional Gain	ExpressionLimit	All set-ups	TRUE	-4	Uint32
30-84	Process PID Proportional Gain	0.100 N/A	All set-ups	TRUE	-3	Uint16

5.4 Remote Programming with MCT 10 Set-up Software

Danfoss offers a software program available for developing, storing, and transferring frequency converter programming. The MCT 10 Set-up Software allows the user to connect a PC to the frequency converter and perform live programming rather than using the LCP. Also, all frequency converter programming can be done off-line and simply downloaded into frequency converter. Or the entire frequency converter profile can be loaded onto the PC for back up storage or analysis.

The USB connector or RS485 terminal are available for connecting to the frequency converter.

MCT 10 Set-up Software with limited functionality is available for free download at www.Danfoss.com. Enter 'MCT-10 download' in the search window. MCT 10 Setup software with full functionality is available on CD, part no. 130B1000. For more information refer to the *MCT 10 Set-up Software Operating Instructions, MG10RXY*.

6 Status Indication

6.1 Frontal LEDs

The actual status can be read via 6 LEDs, which signal the actual status of the unit. The meaning of each LED is described in *Table 6.1*.

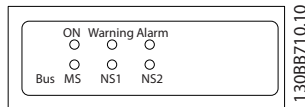

Illustration 6.1 Frontal LEDs

Name	Colour	Status	Indication
ON	Green	On	The frequency converter receives power from mains voltage, or external 24 V supply.
		Off	No power from mains voltage, or external 24 V supply.
Warning	Yellow	On	Warning situation is present.
		Off	No warning is present.
Alarm	Red	Flashing	Alarm is present.
		Off	No alarm is present
Bus MS	Only relevant if optional fieldbus is present. See <i>Profibus manual: MG34NXYY</i> , <i>Ethernet manual: MG90JXYY</i> and <i>ProfiNet manual: MG90UXYY</i> , for specific information.		Bus Module Status
Bus NS1		Bus Network Status 1	
Bus NS2		Bus Network Status 2	

Table 6.1 LED Status

6.2 Status Display

When the frequency converter is in status mode, status messages are generated automatically from within the frequency converter and appear in the bottom line of the display (see *Illustration 6.2*.)

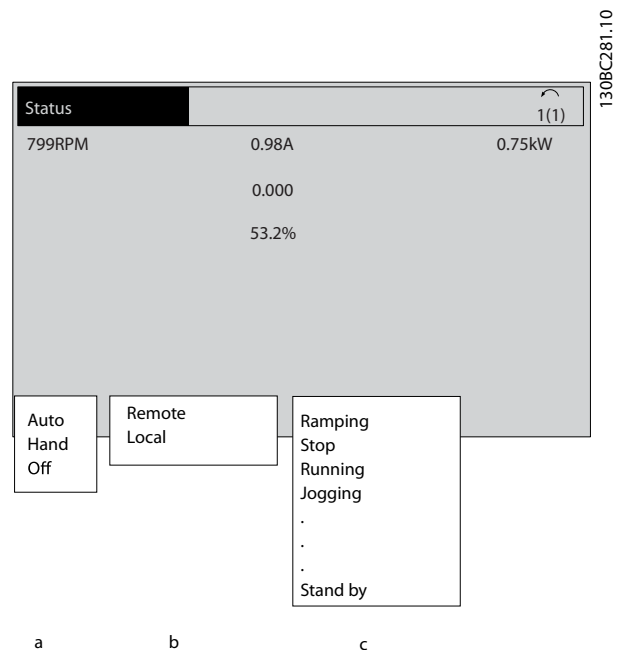

Illustration 6.2 Status Display

- The first word in the status line indicates where the stop/start command originates.
- The second word in the status line indicates where the speed control originates.
- The last part of the status line gives the present frequency converter status. These show the operational mode the frequency converter is in.

NOTICE

In auto/remote mode, the frequency converter requires external commands to execute functions.

6.3 Status Message Definitions

Table 6.2 to Table 6.4 describe the shown status messages.

Off	The frequency converter does not react to any control signal until [Auto On] or [Hand On] is pressed.
Auto On	The frequency converter is controlled from the control terminals and/or the serial communication.
Hand On	Control the unit via the navigation keys on the LCP. Stop commands, reset, reversing, DC brake, and other signals applied to the control terminals can override local control.

Table 6.2 Operating mode

Remote	The speed reference is given from external signals, serial communication, or internal preset references.
Local	The frequency converter uses [Hand On] control or reference values from the LCP.

Table 6.3 Reference Site

AC Brake	AC Brake was selected in <i>parameter 2-10 Brake Function</i> . The AC brake over-magnetizes the motor to achieve a controlled slow down.
AMA finish OK	Automatic motor adaptation (AMA) was carried out successfully.
AMA ready	AMA is ready to start. Press [Hand On] to start.
AMA running	AMA process is in progress.
Braking	The brake chopper is in operation. The brake resistor absorbs generative energy.
Braking max.	The brake chopper is in operation. The power limit for the brake resistor has been reached.
Coast	<ul style="list-style-type: none"> Coast inverse was selected as a function for a digital input (<i>parameter group 5-1* Digital Inputs</i>). The corresponding terminal is not connected. Coast activated by serial communication
Ctrl. Ramp-down	<p>Ctrl. Ramp-down was selected in <i>parameter 14-10 Mains Failure</i>.</p> <ul style="list-style-type: none"> The mains voltage is below the value set in <i>parameter 14-11 Mains Voltage at Mains Fault</i> at mains fault The frequency converter ramps down the motor using a controlled ramp down
Current High	The frequency converter output current is above the limit set in <i>parameter 4-51 Warning Current High</i> .
Current Low	The frequency converter output current is below the limit set in <i>parameter 4-52 Warning Speed Low</i>

DC Hold	DC hold is selected in <i>parameter 1-80 Function at Stop</i> and a stop command is active. The motor is held by a DC current set in <i>parameter 2-00 DC Hold/Preheat Current</i> .
DC Stop	<p>The motor is held with a DC current (<i>parameter 2-01 DC Brake Current</i>) for a specified time (<i>parameter 2-02 DC Braking Time</i>).</p> <ul style="list-style-type: none"> DC brake is activated in <i>parameter 2-03 DC Brake Cut In Speed [RPM]</i> and a stop command is active. DC brake (inverse) is selected as a function for a digital input (<i>parameter group 5-1* Digital Inputs</i>). The corresponding terminal is not active. The DC brake is activated via serial communication.
Feedback high	The sum of all active feedbacks is above the feedback limit set in <i>parameter 4-57 Warning Feedback High</i> .
Feedback low	The sum of all active feedbacks is below the feedback limit set in <i>parameter 4-56 Warning Feedback Low</i> .
Freeze output	<p>The remote reference is active, which holds the present speed.</p> <ul style="list-style-type: none"> Freeze output was selected as a function for a digital input (<i>parameter group 5-1* Digital Inputs</i>). The corresponding terminal is active. Speed control is only possible via the terminal functions speed up and speed down. Hold ramp is activated via serial communication.
Freeze output request	A freeze output command has been given, but the motor remains stopped until a run permissive signal is received.
Freeze ref.	<i>Freeze Reference</i> was selected as a function for a digital input (<i>parameter group 5-1* Digital Inputs</i>). The corresponding terminal is active. The frequency converter saves the actual reference. Changing the reference is now only possible via terminal functions speed up and speed down.
Jog request	A jog command has been given, but the motor remains stopped until a run permissive signal is received via a digital input.

Jogging	<p>The motor is running as programmed in <i>parameter 3-19 Jog Speed [RPM]</i>.</p> <ul style="list-style-type: none"> • Jog was selected as function for a digital input (<i>parameter group 5-1* Digital Inputs</i>). The corresponding terminal is active. • The jog function is activated via the serial communication. • The jog function was selected as a reaction for a monitoring function. The monitoring function is active.
Motor check	<p>In <i>parameter 1-80 Function at Stop, Motor Check</i> was selected. A stop command is active. To ensure that a motor is connected to the frequency converter, a permanent test current is applied to the motor.</p>
OVC Control	<p><i>Overvoltage</i> control was activated in <i>parameter 2-17 Over-voltage Control, [2] Enabled</i>. The connected motor supplies the frequency converter with generative energy. The overvoltage control adjusts the V/Hz ratio to run the motor in controlled mode and to prevent the frequency converter from tripping.</p>
Power Unit Off	<p>(Only frequency converters with a 24 V external supply installed). Mains supply to the frequency converter is removed, but the control card is supplied by the external 24 V.</p>
Protection md	<p>Protection mode is active. The unit has detected a critical status (an overcurrent or overvoltage).</p> <ul style="list-style-type: none"> • To avoid tripping, the switching frequency is reduced to 4 kHz. • If possible, protection mode ends after approximately 10 s. • Protection mode can be restricted in <i>parameter 14-26 Trip Delay at Inverter Fault</i>.
QStop	<p>The motor is decelerating using <i>parameter 3-81 Quick Stop Ramp Time</i>.</p> <ul style="list-style-type: none"> • <i>Quick stop inverse</i> was selected as a function for a digital input (<i>parameter group 5-1* Digital Inputs</i>). The corresponding terminal is not active. • The quick stop function was activated via serial communication.
Ramping	<p>The motor is accelerating/decelerating using the active ramp up/down. The reference, a limit value, or a standstill is not yet reached.</p>
Ref. high	<p>The sum of all active references is above the reference limit set in <i>parameter 4-55 Warning Reference High</i>.</p>
Ref. low	<p>The sum of all active references is below the reference limit set in <i>parameter 4-54 Warning Reference Low</i>.</p>

Run on ref.	<p>The frequency converter is running in the reference range. The feedback value matches the setpoint value.</p>
Run request	<p>A start command has been given, but the motor is stopped until a run permissive signal is received via digital input.</p>
Running	<p>The frequency converter drives the motor.</p>
Sleep Mode	<p>The energy saving function is enabled. The motor has stopped, but restarts automatically when required.</p>
Speed high	<p>Motor speed is above the value set in <i>parameter 4-53 Warning Speed High</i>.</p>
Speed low	<p>Motor speed is below the value set in <i>parameter 4-52 Warning Speed Low</i>.</p>
Standby	<p>In Auto On mode, the frequency converter starts the motor with a start signal from a digital input or serial communication.</p>
Start delay	<p>In <i>parameter 1-71 Start Delay</i>, a delay starting time was set. A start command is activated and the motor starts after the start delay time expires.</p>
Start fwd/rev	<p>Start forward and start reverse were selected as functions for 2 different digital inputs (<i>parameter group 5-1* Digital Inputs</i>). The motor starts in forward or reverse depending on which corresponding terminal is activated.</p>
Stop	<p>The frequency converter has received a stop command from the LCP, digital input, or serial communication.</p>
Trip	<p>An alarm occurred and the motor is stopped. Once the cause of the alarm is cleared, the frequency converter can be reset manually by pressing [Reset] or remotely by control terminals or serial communication.</p>
Trip lock	<p>An alarm occurred and the motor is stopped. Once the cause of the alarm is cleared, power must be cycled to the frequency converter. The frequency converter can then be reset manually by pressing [Reset] or remotely by control terminals or serial communication.</p>

Table 6.4 Operation Status
NOTICE

In auto/remote mode, the frequency converter requires external commands to execute functions.

7 Troubleshooting

7.1.1 Warnings/Alarm Messages

A warning or an alarm appears as an LED signal on the front of the frequency converter, and is indicated by a code on the display.

A warning remains active until its cause is no longer present. Under certain circumstances, the motor can still continue to operate. Warning messages can be critical, but are not necessarily so.

If there is an alarm, the frequency converter trips. Alarms must be reset to restart operation once their cause has been rectified.

Perform the reset in one of three ways:

1. By pressing [Reset] on the LCP.
2. Via a digital input with the "Reset" function.
3. Via serial communication/optional fieldbus.

NOTICE

After a manual reset pressing [Reset] on the LCP, [Auto On] must be pressed to restart the motor.

If an alarm cannot be reset, the reason may be that its cause has not been rectified, or the alarm is trip-locked (see also *Table 7.1*).

Alarms that are trip-locked offer additional protection, meaning that the mains supply must be switched off

before the alarm can be reset. After being switched back on, the frequency converter is no longer blocked. Reset the frequency converter as described above, once the cause of the alarm has been rectified.

Alarms that are not trip-locked can also be reset using the automatic reset function in *parameter 14-20 Reset Mode*.

⚠ WARNING

AUTOMATIC RESTART

Automatic wake-up is possible after resetting the frequency converter. This can cause the motor to be started, possibly resulting in death or serious injury. Make sure, that the motor working area is kept clear.

When a warning and alarm are marked against a code in *Table 7.1*, this means that either a warning occurs before an alarm, or else that the user can specify whether a given fault will trigger a warning or an alarm.

Example: *parameter 1-90 Motor Thermal Protection*. After an alarm or trip, the motor carries on coasting, and the alarm and warning flash. Once the problem has been rectified, only the alarm continues flashing until the frequency converter is reset.

No.	Description	Warning	Alarm/Trip	Alarm/Trip Lock	Parameter Reference
1	10 Volts low	X			
2	Live zero error	(X)	(X)		<i>Parameter 6-01 Live Zero Timeout Function</i>
3	No motor	(X)			<i>Parameter 1-80 Function at Stop</i>
4	Mains phase loss	(X)	(X)	(X)	<i>Parameter 14-12 Function at Mains Imbalance</i>
5	DC link voltage high	X			
6	DC link voltage low	X			
7	DC over-voltage	X	X		
8	DC under voltage	X	X		
9	Inverter overloaded	X	X		
10	Motor ETR over temperature	(X)	(X)		<i>Parameter 1-90 Motor Thermal Protection</i>
11	Motor thermistor over temperature	(X)	(X)		<i>Parameter 1-90 Motor Thermal Protection</i>
12	Torque limit	X	X		
13	Over Current	X	X	X	
14	Earth Fault	X	X	X	
15	Hardware mismatch		X	X	
16	Short Circuit		X	X	
17	Control word time-out	(X)	(X)		<i>Parameter 8-04 Control Timeout Function</i>

No.	Description	Warning	Alarm/Trip	Alarm/Trip Lock	Parameter Reference
22	Hoist Mech. Brake	(X)	(X)		Parameter group 2-2*
23	Internal Fan Fault	X			
25	Brake resistor short-circuited	X			
26	Brake resistor power limit	(X)	(X)		<i>Parameter 2-13 Brake Power Monitoring</i>
27	Brake chopper short-circuited	X	X		
28	Brake check	(X)	(X)		<i>Parameter 2-15 Brake Check</i>
29	Heatsink temp	X	X	X	
30	Motor phase U missing	(X)	(X)	(X)	<i>Parameter 4-58 Missing Motor Phase Function</i>
31	Motor phase V missing	(X)	(X)	(X)	<i>Parameter 4-58 Missing Motor Phase Function</i>
32	Motor phase W missing	(X)	(X)	(X)	<i>Parameter 4-58 Missing Motor Phase Function</i>
33	Inrush Fault		X	X	
34	Fieldbus communication fault	X	X		
36	Mains failure	X	X		
37	Phase imbalance		X		
38	Internal Fault		X	X	
39	Heatsink sensor		X	X	
40	Overload of Digital Output Terminal 27	(X)			<i>Parameter 5-00 Digital I/O Mode, parameter 5-01 Terminal 27 Mode</i>
41	Overload of Digital Output Terminal 29	(X)			<i>Parameter 5-00 Digital I/O Mode, parameter 5-02 Terminal 29 Mode</i>
45	Earth Fault 2	X	X	X	
46	Pwr. card supply		X	X	
47	24 V supply low	X	X	X	
48	1.8 V supply low		X	X	
49	Speed limit	X			
50	AMA calibration failed		X		
51	AMA check U_{nom} and I_{nom}		X		
52	AMA low I_{nom}		X		
53	AMA motor too big		X		
54	AMA motor too small		X		
55	AMA parameter out of range		X		
56	AMA interrupted by user		X		
57	AMA time-out		X		
58	AMA internal fault	X	X		
59	Current limit	X			
60	External Interlock	X	X		
61	Feedback Error	(X)	(X)		<i>Parameter 4-30 Motor Feedback Loss Function</i>
62	Output Frequency at Maximum Limit	X			
63	Mechanical Brake Low		(X)		<i>Parameter 2-20 Release Brake Current</i>
64	Voltage Limit	X			
65	Control Board Over-temperature	X	X	X	
66	Heat sink Temperature Low	X			
67	Option Configuration has Changed		X		
68	Safe Stop	(X)	(X) ¹⁾		<i>Parameter 5-19 Terminal 37 Safe Stop</i>
69	Pwr. Card Temp		X	X	
70	Illegal FC configuration			X	
73	Safe Stop Auto Restart	(X)	(X)		<i>Parameter 5-19 Terminal 37 Safe Stop</i>
76	Power Unit Setup	X			

No.	Description	Warning	Alarm/Trip	Alarm/Trip Lock	Parameter Reference
77	Reduced power mode	X			Parameter 14-59 Actual Number of Inverter Units
78	Tracking Error	(X)	(X)		Parameter 4-34 Tracking Error Function
79	Illegal PS config		X	X	
80	Drive Initialized to Default Value		X		
81	CSIV corrupt		X		
82	CSIV parameter error		X		
85	Profibus/Profisafe Error		X		
90	Feedback Monitor	(X)	(X)		Parameter 17-61 Feedback Signal Monitoring
91	Analogue input 54 wrong settings			X	S202
250	New spare part			X	Parameter 14-23 Typecode Setting
251	New Type Code		X	X	

Table 7.1 Alarm/Warning Code List

(X) Dependent on parameter

1) Can not be Auto reset via parameter 14-20 Reset Mode

A trip is the action performed when an alarm arises. The trip causes the motor to coast. Reset the trip by pressing [Reset], or perform a reset via a digital input (parameter group 5-1* [1]). Trip is used when the original event causing the alarm cannot damage the frequency converter or cause dangerous conditions. A trip lock is the action performed when an alarm occurs, which can cause damage to the frequency converter or connected parts. A trip lock situation can only be reset by a power cycling.

LED Indication	
Warning	yellow
Alarm	flashing red
Trip locked	yellow and red

Table 7.2 LED Indicator Status



Alarm Word Extended Status Word							
Bit	Hex	Dec	Alarm Word	Alarm Word 2	Warning Word	Warning Word 2	Extended Status Word
0	00000001	1	Brake Check (A28)	ServiceTrip, Read/Write	Brake Check (W28)	reserved	Ramping
1	00000002	2	Heatsink temp. (A29)	ServiceTrip, (reserved)	Heatsink temp. (W29)	reserved	AMA Running
2	00000004	4	Earth Fault (A14)	ServiceTrip, Typecode/Sparepart	Earth Fault (W14)	reserved	Start CW/CCW
3	00000008	8	Ctrl.Card Temp (A65)	ServiceTrip, (reserved)	Ctrl.Card Temp (W65)	reserved	Slow Down
4	00000010	16	Ctrl. Word TO (A17)	ServiceTrip, (reserved)	Ctrl. Word TO (W17)		Catch Up
5	00000020	32	Over Current (A13)	reserved	Over Current (W13)	reserved	Feedback High
6	00000040	64	Torque Limit (A12)	reserved	Torque Limit (W12)	reserved	Feedback Low
7	00000080	128	Motor Th Over (A11)	reserved	Motor Th Over (W11)	reserved	Output Current High
8	00000100	256	Motor ETR Over (A10)	reserved	Motor ETR Over (W10)	reserved	Output Current Low
9	00000200	512	Inverter Overld. (A9)	reserved	Inverter Overld (W9)	reserved	Output Freq High
10	00000400	1024	DC under Volt (A8)	reserved	DC under Volt (W8)		Output Freq Low
11	00000800	2048	DC over Volt (A7)	reserved	DC over Volt (W7)		Brake Check OK
12	00001000	4096	Short Circuit (A16)	reserved	DC Voltage Low (W6)	reserved	Braking Max
13	00002000	8192	Inrush Fault (A33)	reserved	DC Voltage High (W5)		Braking
14	00004000	16384	Mains ph. Loss (A4)	reserved	Mains ph. Loss (W4)		Out of Speed Range
15	00008000	32768	AMA Not OK	reserved	No Motor (W3)		OVC Active
16	00010000	65536	Live Zero Error (A2)	reserved	Live Zero Error (W2)		AC Brake
17	00020000	131072	Internal Fault (A38)	KTY error	10V Low (W1)	KTY Warn	Password Timelock
18	00040000	262144	Brake Overload (A26)	Fans error	Brake Overload (W26)	Fans Warn	Password Protection
19	00080000	524288	U phase Loss (A30)	ECB error	Brake Resistor (W25)	ECB Warn	
20	00100000	1048576	V phase Loss (A31)	reserved	Brake IGBT (W27)	reserved	
21	00200000	2097152	W phase Loss (A32)	reserved	Speed Limit (W49)	reserved	
22	00400000	4194304	Fieldbus Fault (A34)	reserved	Fieldbus Fault (W34)	reserved	Unused
23	00800000	8388608	24V Supply Low (A47)	reserved	24V Supply Low (W47)	reserved	Unused
24	01000000	16777216	Mains Failure (A36)	reserved	Mains Failure (W36)	reserved	Unused
25	02000000	33554432	1.8V Supply Low (A48)	reserved	Current Limit (W59)	reserved	Unused
26	04000000	67108864	Brake Resistor (A25)	reserved	Low Temp (W66)	reserved	Unused
27	08000000	134217728	Brake IGBT (A27)	reserved	Voltage Limit (W64)	reserved	Unused
28	10000000	268435456	Option Change (A67)	reserved	Encoder loss (W90)	reserved	Unused
29	20000000	536870912	Drive Initialized(A80)	Feedback Fault (A61, A90)	Feedback Fault (W61, W90)		Unused
30	40000000	1073741824	Safe Stop (A68)	PTC 1 Safe Stop (A71)	Safe Stop (W68)	PTC 1 Safe Stop (W71)	Unused
31	80000000	2147483648	Mech. brake low (A63)	Dangerous Failure (A72)	Extended Status Word		Unused

Table 7.3 Description of Alarm Word, Warning Word and Extended Status Word

The alarm words, warning words and extended status words can be read out via serial bus or optional fieldbus for diagnosis. See also *parameter 16-94 Ext. Status Word*.

WARNING 1, 10 Volts low

The 10 V voltage from terminal 50 on the control card is below 10 V.

Remove some of the load from terminal 50, as the 10 V supply is overloaded. Max. 15 mA or minimum 590 Ω .

WARNING/ALARM 2, Live zero error

The signal on terminal 53 or 54 is less than 50% of the value set in *parameter 6-10 Terminal 53 Low Voltage*, *parameter 6-12 Terminal 53 Low Current*, *parameter 6-20 Terminal 54 Low Voltage*, or *parameter 6-22 Terminal 54 Low Current* respectively.

WARNING/ALARM 3, No motor

No motor has been connected to the output of the frequency converter.

WARNING/ALARM 4, Mains phase loss

A phase is missing on the supply side, or the mains voltage imbalance is too high.

This message also appears in the event of a fault in the input rectifier on the frequency converter.

Check the supply voltage and supply currents to the frequency converter.

WARNING 5, DC link voltage high

The intermediate circuit voltage (DC) is higher than the overvoltage limit of the control system. The frequency converter is still active.

WARNING 6, DC link voltage low

The intermediate circuit voltage (DC) is below the undervoltage limit of the control system. The frequency converter is still active.

WARNING/ALARM 7, DC over voltage

If the intermediate circuit voltage exceeds the limit, the frequency converter trips after a time.

Possible corrections:

Connect a brake resistor

Extend the ramp time

Activate functions in *parameter 2-10 Brake Function*

Increase *parameter 14-26 Trip Delay at Inverter Fault*

WARNING/ALARM 8, DC under voltage

If the intermediate circuit voltage (DC) drops below the "voltage warning low" limit (see *Table 7.3*), the frequency converter checks if 24 V backup supply is connected.

If no 24 V backup supply is connected, the frequency converter trips after a given time depending on the unit.

To check whether the supply voltage matches the frequency converter, see *chapter 8.2 General Specifications*.

WARNING/ALARM 9, Inverter overloaded

The frequency converter is about to cut out because of an overload (too high current for too long). The counter for electronic, thermal inverter protection warns at 98% and trips at 100%, while giving an alarm. The frequency converter **cannot** be reset until the counter is below 90%. The fault is that the frequency converter overloads more than 100% for too long.

WARNING/ALARM 10, Motor ETR electronic overload over temperature

According to the electronic thermal protection (ETR), the motor is too hot. Select whether the frequency converter will trigger a warning or an alarm when the counter reaches 100% in *parameter 1-90 Motor Thermal Protection*. The fault is that the motor overloads more than 100% for too long. Check that the motor *parameter 1-24 Motor Current* is set correctly.

WARNING/ALARM 11, Motor thermistor over temp

The motor has exceeded the temperature limit. Wait until the motor is cooled down. The thermistor or the thermistor connection disconnects when the temperature limit is exceeded. Set the frequency converter to give either a warning or an alarm when the counter reaches 100% in *parameter 1-90 Motor Thermal Protection*. Check that the thermistor is connected correctly between terminal 53 or 54 (analog voltage input) and terminal 50 (+ 10 V supply), or between terminal 18 or 19 (digital input PNP only) and terminal 50. If a KTY sensor is used, check for correct connection between terminal 54 and 55.

WARNING/ALARM 12, Torque limit

The torque is higher than the value in *parameter 4-16 Torque Limit Motor Mode* (in motor operation) or the torque is higher than the value in *parameter 4-17 Torque Limit Generator Mode* (in regenerative operation).

WARNING/ALARM 13, Over Current

The inverter peak current limit (approx. 200% of the rated current) is exceeded. The warning lasts approx. 8-12 s, then the frequency converter trips and issues an alarm. Turn off the frequency converter and check if the motor shaft can be turned and if the motor size matches the frequency converter.

If extended mechanical brake control is selected, trip can be reset externally.

ALARM 14, Earth fault

There is a discharge from the output phases to earth, either in the cable between the frequency converter and the motor or in the motor itself.

Turn off the frequency converter and remove the earth fault.

ALARM 15, Incomplete hardware

The control board (hardware or software) does not support a fitted option.

ALARM 16, Short-circuit

There is short-circuiting in the motor or on the motor terminals.

Turn off the frequency converter and remove the short-circuit.

WARNING/ALARM 17, Control word timeout

There is no communication to the frequency converter. The warning is only active when *parameter 8-04 Control Timeout Function* is NOT set to [Off].

If *parameter 8-04 Control Timeout Function* is set to [Stop] and [Trip], a warning appears and the frequency converter ramps down until it trips, while giving an alarm.

Parameter 8-03 Control Timeout Time could possibly be increased.

WARNING/ALARM 22, Hoist Mechanical Brake

The report value shows what kind of it is. 0=The torque ref. was not reached before timeout. 1=There was no brake feedback before timeout.

WARNING 23, Internal fan fault

The fan warning function is an extra protection function that checks if the fan is running/mounted. The fan warning can be disabled in *parameter 14-53 Fan Monitor* (set to [0] Disabled).

WARNING 25, Brake resistor short-circuited

The brake resistor is monitored during operation. If it short-circuits, the brake function is disconnected and the warning appears. The frequency converter still works, but without the brake function. Turn off the frequency converter and replace the brake resistor (see *parameter 2-15 Brake Check*).

WARNING/ALARM 26, Brake resistor power limit

The power transmitted to the brake resistor is calculated as a percentage, as a mean value over the last 120 s, based on the resistance value of the brake resistor (*parameter 2-11 Brake Resistor (ohm)*) and the intermediate circuit voltage. The warning is active when the dissipated braking power is higher than 90%. If [2] Trip has been selected in *parameter 2-13 Brake Power Monitoring*, the frequency converter cuts out and issues this alarm, when the dissipated braking power is higher than 100%.

WARNING/ALARM 27, Brake chopper fault

The brake transistor is monitored during operation and if it short-circuits, the brake function disconnects and the warning comes up. The frequency converter is still able to run. However because the brake transistor has short-circuited, substantial power is transmitted to the brake resistor, even when it is inactive.

Turn off the frequency converter and remove the brake resistor.

This alarm/ warning can also arise due to overheating of the brake resistor. Terminals 104 to 106 are available as brake resistor, with Klixon inputs.

WARNING**ELECTRICAL HAZARD**

There is a risk of substantial power being transmitted to the brake resistor if the brake transistor is short-circuited. Death, severe injury, or damage can occur. Keep clear from the brake resistor and the electrical connections.

WARNING/ALARM 28, Brake check failed

Brake resistor fault: the brake resistor is not connected/working.

ALARM 29, Drive over temperature

The cut-out temperature of the heat-sink is 95 °C ±5 °C. The temperature fault cannot be reset, until the temperature of the heatsink is below 70 °C ±5 °C.

The fault could be:

- Ambient temperature too high
- Too long motor cable

ALARM 30, Motor phase U missing

Motor phase U between the frequency converter and the motor is missing.

Turn off the frequency converter and check motor phase U.

ALARM 31, Motor phase V missing

Motor phase V between the frequency converter and the motor is missing.

Turn off the frequency converter and check motor phase V.

ALARM 32, Motor phase W missing

Motor phase W between the frequency converter and the motor is missing.

Turn off the frequency converter and check motor phase W.

ALARM 33, Inrush fault

Too many power ups have occurred within a short time period. See *chapter 8.2 General Specifications* for the allowed number of power ups within 1 minute.

WARNING/ALARM 34, Fieldbus communication fault

The fieldbus on the communication option card is not working correctly. Check parameters associated with the module and check the wiring for fieldbus.

WARNING/ALARM 36, Mains failure

This warning/alarm is only active if the supply voltage to the frequency converter is lost and *parameter 14-10 Mains Failure* is NOT set to [Off]. Possible correction: check the fuses to the frequency converter

ALARM 37, Phase imbalance

There is a current imbalance between the power units

ALARM 38, Internal fault

When this alarm arises, it can be necessary to contact the Danfoss supplier. Some typical alarm messages:

0	The serial port cannot be initialized. Serious hardware failure
256	The power EEPROM data is defect or too old
512	The control board EEPROM data is defect or too old
513	Communication time out Reading EEPROM data
514	Communication time out Reading EEPROM data
515	The Application Orientated Control cannot recognize the EEPROM data
516	Cannot write to the EEPROM because a write command is on progress
517	The write command is under time-out
518	Failure in the EEPROM
519	Missing or invalid BarCode data in EEPROM 1024-1279 CAN telegram cannot be sent. (1027 indicate a possible hardware failure)
1281	Digital Signal Processor flash time-out
1282	Power micro software version mismatch
1283	Power EEPROM data version mismatch
1284	Cannot read Digital Signal Processor software version
1299	Option SW in slot A is too old
1300	Option SW in slot B is too old
1315	Option SW in slot A is not supported (not allowed)
1316	Option SW in slot B is not supported (not allowed)
1536	An exception in the Application Orientated Control is registered. Debug information written in LCP
1792	DSP watchdog is active. Debugging of power part data Motor Orientated Control data not transferred correctly
2049	Power data restarted
2315	Missing SW version from power unit
2816	Stack overflow Control board module
2817	Scheduler slow tasks
2818	Fast tasks
2819	Parameter thread
2820	LCP stack overflow
2821	Serial port overflow
2822	USB port overflow
3072-5122	Parameter value is outside its limits. Perform an initialization. Parameter number causing the alarm: Subtract the code from 3072. Ex Error code 3238: 3238-3072=166 is outside the limit
5123	Option in slot A: Hardware incompatible with Control board hardware
5124	Option in slot B: Hardware incompatible with Control board hardware
5376-6231	Out of memory

ALARM 39, Heatsink sensor

No feedback from the heatsink temperature sensor.

The signal from the IGBT thermal sensor is not available on the power card. The problem could be on the power card, on the gate drive card, or the ribbon cable between the power card and gate drive card.

WARNING 40, Overload of Digital Output Terminal 27

Check the load connected to terminal 27 or remove short-circuit connection. Check *parameter 5-00 Digital I/O Mode* and *parameter 5-01 Terminal 27 Mode*.

WARNING 41, Overload of Digital Output Terminal 29

Check the load connected to terminal 29 or remove short-circuit connection. Check *parameter 5-00 Digital I/O Mode* and *parameter 5-02 Terminal 29 Mode*.

ALARM 45, Earth fault 2

There is a discharge from the output phases to earth, either in the cable between the frequency converter and the motor or in the motor itself. Turn off the frequency converter and remove the earth fault. This alarm is detected under the start-up test sequence.

ALARM 46, Power card supply

The supply on the power card is out of range.

There are three power supplies generated by the switch mode power supply (SMPS) on the power card: 24 V, 5 V, +/-18 V. When powered with 24 V DC with the MCB 107 option, only the 24 V and 5 V supplies are monitored. When powered with three-phase mains voltage, all three phases supplied are monitored.

WARNING 47, 24 V supply low

The external 24 V DC backup power supply may be overloaded, otherwise Contact your Danfoss supplier.

WARNING 48, 1.8 V supply low

Contact your Danfoss supplier.

WARNING 49, Speed limit

The speed is not within the specified range in *parameter 4-11 Motor Speed Low Limit [RPM]* and *parameter 4-13 Motor Speed High Limit [RPM]*.

ALARM 50, AMA calibration failed

The motor is not suitable for the particular size of drive. Start the AMA procedure once again by *parameter 1-29 Automatic Motor Adaptation (AMA)*, eventually with a reduced AMA function. If still failing; check the motor data.

ALARM 51, AMA check Unom and Inom

The setting of motor voltage, motor current, and motor power is presumably wrong. Check the settings.

ALARM 52, AMA low Inom

The motor current is too low. Check the settings.

ALARM 53, AMA motor too big

The motor is too large for the AMA to be carried out.

ALARM 54, AMA motor too small

The motor is too small for the AMA to be carried out.

ALARM 55, AMA par. out of range

The motor parameter values found from the motor are outside acceptable range.

ALARM 56, AMA interrupted by user

The AMA has been interrupted by the user.

ALARM 57, AMA timeout

Try to start the AMA again a number of times, until the AMA is carried out. Note that repeated runs may heat the motor to a level where the resistance R_s and R_r are increased. In most cases, however, this is not critical.

ALARM 58, AMA internal fault

Contact your Danfoss supplier.

WARNING 59, Current limit

The current is higher than the value in *parameter 4-18 Current Limit*.

WARNING 60, External interlock

External interlock has been activated. To resume normal operation, apply 24 V DC to the terminal programmed for external interlock and reset the frequency converter (via serial communication, digital I/O, or by pressing [Reset]).

WARNING/ALARM 61, Feedback Error

An error between calculated speed and speed measurement from feedback device. The function Warning/Alarm/Disabling setting is in *parameter 4-30 Motor Feedback Loss Function*. Accepted error setting in *parameter 4-31 Motor Feedback Speed Error* and the allowed time the error occur setting in *parameter 4-32 Motor Feedback Loss Timeout*. During a commissioning procedure the function may be effective.

WARNING 62, Output Frequency at Maximum Limit

The output frequency is higher than the value set in *parameter 4-19 Max Output Frequency*. This is a warning in VVC⁺ mode and an alarm (trip) in Flux mode.

ALARM 63, Mechanical Brake Low

The actual motor current has not exceeded the "release brake" current within the "Start delay" time window.

WARNING 64, Voltage Limit

The load and speed combination demands a motor voltage higher than the actual DC link voltage.

WARNING/ALARM/TRIP 65, Control Card Over Temperature

Control card over temperature: The cut-out temperature of the control card is 80 °C.

WARNING 66, Heatsink Temperature Low

The heat sink temperature is measured as 0 °C. This could indicate that the temperature sensor is defect. Thus the fan speed is increased to the maximum in case the power part or control card is very hot.

ALARM 67, Option Configuration has Changed

One or more options has either been added or removed since the last power down.

ALARM 68, Safe Stop

Safe Stop has been activated. To resume normal operation, apply 24 V DC to T-37. Press [Reset].

WARNING 68, Safe Stop

Safe Stop has been activated. Normal operation is resumed when Safe Stop is disabled.

WARNING**AUTOMATIC RESTART**

Automatic restart is possible after disabling Safe Stop. This can cause the motor to be started, possibly resulting in death or serious injury. Make sure, that the motor working area is kept clear.

ALARM 69, Power card temperature

The temperature sensor on the power card is either too hot or too cold.

ALARM 70, Illegal FC Configuration

Actual combination of control board and power board is illegal.

WARNING 73, Safe stop auto restart

Safe stopped. Note that with automatic restart enabled, the motor can start when the fault is cleared.

WARNING 76, Power Unit Setup

The required number of power units does not match the detected number of active power units.

WARNING 77, Reduced power mode

This warning indicates that the drive is operating in reduced power mode (that is, less than the allowed number of inverter sections). This warning generates on power cycle when the frequency converter is set to run with fewer inverters and remains on.

ALARM 78, Tracking Error

The difference between set point value and actual value has exceeded the value in *parameter 4-35 Tracking Error*. Disable the function by *parameter 4-34 Tracking Error Function* or select an alarm/warning also in *parameter 4-34 Tracking Error Function*. Investigate the mechanics around the load and motor, Check feedback connections from motor – encoder – to frequency converter. Select motor feedback function in *parameter 4-30 Motor Feedback Loss Function*. Adjust tracking error band in *parameter 4-35 Tracking Error* and *parameter 4-37 Tracking Error Ramping*.

ALARM 79, Illegal power section configuration

The scaling card is the incorrect part number or not installed. Also MK102 connector on the power card could not be installed.

ALARM 80, Drive Initialised to Default Value

Parameter settings are initialised to default setting after a manual (three-finger) reset.

ALARM 81, CSIV corrupt

CSIV file has syntax errors.

ALARM 82, CSIV parameter error

CSIV failed to initialise a parameter.

ALARM 85, Dang fail PB

Profibus/Profisafe Error.

ALARM 86, Dang fail DI

Sensor Error.

ALARM 88, Option Detection

A change in the option layout has been detected. This alarm occurs when *parameter 14-89 Option Detection* is set to [0] *Frozen configuration* and the option layout for some reason has changed. Enable an option layout change in *parameter 14-89 Option Detection* before the change is accepted. If the change of configuration is not accepted, it is only possible to reset Alarm 88 (Trip-lock) when the option configuration has been re-established/corrected.

ALARM 90, Feedback Monitor

Check the connection to encoder/resolver option and eventually replace the MCB 102 or MCB 103.

ALARM 91, Analogue Input 54 Wrong Settings

Switch S202 has to be set in position OFF (voltage input) when a KTY sensor is connected to analogue input terminal 54.

ALARM 250, New Spare Part

The power or Switch Mode Power Supply has been exchanged. The frequency converter type code must be restored in the EEPROM. Select the correct type code in *parameter 14-23 Typecode Setting* according to the label on unit. Remember to select 'Save to EEPROM' to complete.

ALARM 251, New Type Code

The frequency converter has got a new type code.

8 Specifications

8.1 Electrical Data and Wire Sizes

8.1.1 Overview

Mains Supply 3x380-480 V AC									
Frequency converter		PK37	PK55	PK75	P1K1	P1K5	P2K2	P3K0	
Rated Shaft Output [kW]		0.37	0.55	0.75	1.1	1.5	2.2	3.0	
Rated Shaft Output [hp]		0.5	0.75	1.0	1.5	2.0	3.0	4.0	
Max. input current									
 130BB800.10	Continuous (3x380-440 V) [A]	1.2	1.6	2.2	2.7	3.7	5.0	6.5	
	Intermittent (3x380-440 V) [A]	1.9	2.6	3.5	4.3	5.9	8.0	10.4	
	Continuous (3x441-480 V) [A]	1.0	1.4	1.9	2.7	3.1	4.3	5.7	
	Intermittent (3x441-480 V) [A]	1.6	2.2	3.0	4.3	5.0	6.9	9.1	
	Recommended max. fuse size (non UL)	gG-25							
	Built-in circuit breaker (large unit)	CTI-25M Danfoss part no.: 047B3151							
	Recommended circuit breaker Danfoss CTI-25M (small and large unit) part number:								
	0.37, 0.55 kW	Danfoss part no.: 047B3148							
	0.75, 1.1 kW	Danfoss part no.: 047B3149							
	1.5, 2.2 and 3 kW	Danfoss part no.: 047B3151							
	Recommended circuit breaker Danfoss CTI-45MB ¹⁾ (small unit) part number:								
	0.55, 0.75 kW	Danfoss part no.: 047B3160							
	1.1 kW	Danfoss part no.: 047B3161							
	1.5 kW	Danfoss part no.: 047B3162							
	2.2 kW	Danfoss part no.: 047B3163							
	Power loss at max. load [W] ²⁾	35	42	46	58	62	88	116	
Efficiency ³⁾	0.93	0.95	0.96	0.96	0.97	0.97	0.97		
Weight, small unit [kg]	9.8							N/A	
Weight, large unit [kg]	13.9								
Output current									
 130BB799.10	Continuous (3x380-440 V) [A]	1.3	1.8	2.4	3.0	4.1	5.2	7.2	
	Intermittent (3x380-440 V) [A]	2.1	2.9	3.8	4.8	6.6	8.3	11.5	
	Continuous (3x441-480 V) [A]	1.2	1.6	2.1	3.0	3.4	4.8	6.3	
	Intermittent (3x441-480 V) [A]	1.9	2.6	3.4	4.8	5.4	7.7	10.1	
	Continuous kVA (400 V AC) [kVA]	0.9	1.3	1.7	2.1	2.8	3.9	5.0	
	Continuous kVA (460 V AC) [kVA]	0.9	1.3	1.7	2.4	2.7	3.8	5.0	
	Max. cable size: (mains, motor, brake) [mm ² /AWG]	solid cable 6/10 flexible cable 4/12							

Table 8.1 FCD 302 Shaft Output, Output Current and Input Current

1) Type CTI-45MB circuit breakers are not available for 3 kW units.

2) Applies for dimensioning of frequency converter cooling. If the switching frequency is higher than the default setting, the power losses may increase. LCP and typical control card power

consumptions are included. For power loss data according to EN 50598-2, refer to www.danfoss.com/vltenergyefficiency.

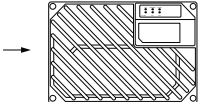
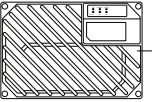
3) Efficiency measured at nominal current. For energy efficiency class, see chapter 8.2 General Specifications. For part load losses see www.danfoss.com/vltenergyefficiency.

8.1.2 UL/cUL Approved Pre-fuses

1. American Wire Gauge. Max. cable cross section is the largest cable cross section that can be attached to the terminals. Always observe national and local regulations.
2. Type gG pre-fuses must be used. To maintain UL/cUL, use pre-fuses of these types (see *Table 8.2*).
3. Measured using a 10 m screened/armoured motor cable with a rated load and rated frequency.

Recommended maximum pre-fuse size 25 A

Brand	Fuse type	UL File number	UL Category (CCN code)
Bussmann	FWH- ¹⁾	E91958	JFHR2
Bussmann	KTS-R ¹⁾	E4273	RK1/JDDZ
Bussmann	JKS- ¹⁾	E4273	J/JDDZ
Bussmann	JJS- ¹⁾	E4273	T/JDDZ
Bussmann	FNQ-R- ¹⁾	E4273	CC/JDDZ
Bussmann	KTK-R- ¹⁾	E4273	CC/JDDZ
Bussmann	LP-CC- ¹⁾	E4273	CC/JDDZ
SIBA	5017906- ¹⁾	E180276	RK1/JDDZ
Little Fuse	KLS-R ¹⁾	E81895	RK1/JDDZ
Ferraz-Shawmut	ATM-R ¹⁾	E2137	CC/JDDZ
Ferraz-Shawmut	A6K-R ¹⁾	E2137	RK1/JDDZ
Ferraz-Shawmut	HSJ ¹⁾	E2137	J/HSJ

Table 8.2 FCD 302 Pre-fuses Meeting UL/cUL Requirements

1) 5 A (0.37 kW), 7A (0.55 kW), 9 A (0.75 kW), 12 A (1.1 kW), 15 A (1.5 kW), 20 A (2.2 kW), 25 A (3 kW)

8.1.3 FCD 302 DC Voltage Levels

DC voltage level	380–480 V units (V DC)
Inverter undervoltage disable	373
Undervoltage warning	410
Inverter undervoltage re-enable (warning reset)	398
Overvoltage warning (without brake)	778
Dynamic brake turn on	778
Inverter overvoltage re-enable (warning reset)	795
Overvoltage warning (with brake)	810
Overvoltage trip	820

Table 8.3 FCD 302 DC Voltage Level

Fuses

The unit is suitable for use on a circuit capable of delivering not more than 100,000 RMS symmetrical Amperes, 500 V maximum.

Circuit breaker

The unit is suitable for use on a circuit capable of delivering not more than 10,000 RMS symmetrical Amperes, 500 V maximum.

8.2 General Specifications

Mains supply (L1, L2, L3)

Supply voltage	380-480 V \pm 10%
----------------	---------------------

Mains voltage low / mains drop-out:

During low mains voltage or a mains drop-out, the frequency converter continues until the intermediate circuit voltage drops below the minimum stop level, which corresponds typically to 15% below the FC's lowest rated supply voltage. Power-up and full torque cannot be expected at mains voltage lower than 10% below the frequency converter's lowest rated supply voltage.

Supply frequency	50/60 Hz \pm 5%
------------------	-------------------

Max. imbalance temporary between mains phases	3.0% of rated supply voltage
---	------------------------------

True Power Factor (λ)	\geq 0.9 nominal at rated load
---------------------------------	----------------------------------

Displacement Power Factor ($\cos \phi$)	near unity ($>$ 0.98)
---	------------------------

Switching on input supply L1, L2, L3 (power-ups)	maximum 2 times/min.
--	----------------------

The unit is suitable for use on a circuit capable of delivering not more than 100,000 RMS symmetrical Amperes, 480 V maximum.

Motor output (U, V, W)

Output voltage	0-100% of supply voltage
----------------	--------------------------

Output frequency	0-590 Hz
------------------	----------

Output frequency in Flux Mode	0-300 Hz
-------------------------------	----------

Switching on output	Unlimited
---------------------	-----------

Ramp times	0.01-3600 s
------------	-------------

Torque Characteristics

Starting torque (Constant torque)	maximum 160% for 60 s ¹⁾
-----------------------------------	-------------------------------------

Starting torque	maximum 180% up to 0.5 s ¹⁾
-----------------	--

Overload torque (Constant torque)	maximum 160% for 60 s ¹⁾
-----------------------------------	-------------------------------------

Starting torque (Variable torque)	maximum 110% for 60 s ¹⁾
-----------------------------------	-------------------------------------

Overload torque (Variable torque)	maximum 110% for 60 s ¹⁾
-----------------------------------	-------------------------------------

1) Percentage relates to the nominal torque.

Cable lengths and cross sections for control cables¹⁾

Max. motor cable length, screened	10 m (32.8 ft)
-----------------------------------	----------------

Max. motor cable length, unscreened, without fulfilling emission specification.	10 m (32.8 ft)
---	----------------

Maximum cross section to control terminals, flexible/ rigid wire without cable end sleeves	1.5 mm ² /16 AWG
--	-----------------------------

Maximum cross section to control terminals, flexible wire with cable end sleeves	1.5 mm ² /16 AWG
--	-----------------------------

Maximum cross section to control terminals, flexible wire with cable end sleeves with collar	1.5 mm ² /16 AWG
--	-----------------------------

Minimum cross section to control terminals	0.25 mm ² / 24 AWG
--	-------------------------------

1) Power cables, see tables in chapter 8.1 Electrical Data and Wire Sizes of the VLT® Decentral Drive FCD 302 Design Guide.

Protection and Features

- Electronic thermal motor protection against overload.
- Temperature monitoring of the heatsink ensures that the frequency converter trips if the temperature reaches a predefined level.
- The frequency converter is protected against short-circuits on motor terminals U, V, W.
- If a mains phase is missing, the frequency converter trips or issues a warning (depending on the load).
- Monitoring of the intermediate circuit voltage ensures that the frequency converter trips if the intermediate circuit voltage is too low or too high.
- The frequency converter constantly checks for critical levels of internal temperature, load current, high voltage on the intermediate circuit and low motor speeds. As a response to a critical level, the frequency converter can adjust the switching frequency and/ or change the switching pattern in order to ensure the performance of the drive.

Digital inputs

Programmable digital inputs	4 (6) ¹⁾
Terminal number	18, 19, 27 ¹⁾ , 29 ¹⁾ , 32, 33,
Logic	PNP or NPN
Voltage level	0-24 V DC
Voltage level, logic '0' PNP	<5 V DC
Voltage level, logic '1' PNP	>10 V DC
Voltage level, logic '0' NPN ²⁾	>19 V DC
Voltage level, logic '1' NPN ²⁾	<14 V DC
Maximum voltage on input	28 V DC
Pulse frequency range	0-110 kHz
(Duty cycle) Min. pulse width	4.5 ms
Input resistance, R _i	approx. 4 k Ω

All digital inputs are galvanically isolated from the supply voltage (PELV) and other high-voltage terminals.

1) Terminals 27 and 29 can also be programmed as output.

Safe stop Terminal 37 (Terminal 37 is fixed PNP logic)

Voltage level	0-24 V DC
Voltage level, logic '0' PNP	<4 V DC
Voltage level, logic '1' PNP	20 V DC
Nominal input current at 24 V	50 mA rms
Nominal input current at 20 V	60 mA rms
Input capacitance	400 nF

Analog inputs

Number of analog inputs	2
Terminal number	53, 54
Modes	Voltage or current
Mode select	Switch S201 and switch S202
Voltage mode	Switch S201/switch S202=OFF (U)
Voltage level	-10 to +10 V (scaleable)
Input resistance, R _i	approx. 10 k Ω
Max. voltage	\pm 20 V
Current mode	Switch S201/switch S202=ON (I)
Current level	0/4 to 20 mA (scaleable)
Input resistance, R _i	approx. 200 Ω
Max. current	30 mA
Resolution for analog inputs	10 bit (+ sign)
Accuracy of analog inputs	Max. error 0.5% of full scale
Bandwidth	100 Hz

The analog inputs are galvanically isolated from the supply voltage (PELV) and other high-voltage terminals.

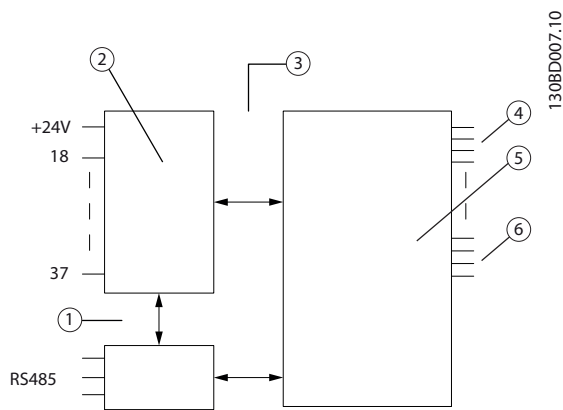

130BD007.10

Item	Description
1	Functional isolation
2	Control
3	PELV isolation
4	Mains
5	High voltage
6	Motor

Table 8.4 Legend

Illustration 8.1 Analog Inputs

8

Pulse/encoder inputs

Programmable pulse/encoder inputs	2/1
Terminal number pulse/encoder	29, 33 ¹⁾ /32 ²⁾ , 33 ²⁾
Max. frequency at terminal 29, 32, 33	110 kHz (Push-pull driven)
Max. frequency at terminal 29, 32, 33	5 kHz (open collector)
Min. frequency at terminal 29, 32, 33	4 Hz
Voltage level	see section Digital Inputs
Maximum voltage on input	28 V DC
Input resistance, R _i	approx. 4 kΩ
Pulse input accuracy (0.1 to 1 kHz)	Max. error: 0.1% of full scale
Encoder input accuracy (1 to 110 kHz)	Max. error: 0.05% of full scale

The pulse and encoder inputs (terminals 29, 32, 33) are galvanically isolated from the supply voltage (PELV) and other high-voltage terminals.

1) Pulse inputs are 29 and 33

2) Encoder inputs: 32=A, and 33=B

Analog output

Number of programmable analog outputs	1
Terminal number	42
Current range at analog output	0/4 to 20 mA
Maximum load GND - analog output less than	500 Ω
Accuracy on analog output	Maximum error: 0.5% of full scale
Resolution on analog output	12 bit

The analog output is galvanically isolated from the supply voltage (PELV) and other high-voltage terminals.

Control card, RS485 serial communication

Terminal number	68 (P, TX+, RX+), 69 (N, TX-, RX-)
Terminal number 61	Common for terminals 68 and 69

The RS485 serial communication circuit is functionally separated from other central circuits and galvanically isolated from the supply voltage (PELV).

Digital output

Programmable digital/pulse outputs	2
Terminal number	27, 29 ¹⁾
Voltage level at digital/frequency output	0-24 V
Max. output current (sink or source)	40 mA
Max. load at frequency output	1 kΩ
Max. capacitive load at frequency output	10 nF
Minimum output frequency at frequency output	0 Hz
Maximum output frequency at frequency output	32 kHz

Accuracy of frequency output	Max. error: 0.1% of full scale
Resolution of frequency outputs	12 bit

1) Terminal 27 and 29 can also be programmed as input.

The digital output is galvanically isolated from the supply voltage (PELV) and other high-voltage terminals.

Control card, 24 V DC output

Terminal number	12, 13
Output voltage	24 V +1, -3 V
Max. load	600 mA

The 24 V DC supply is galvanically isolated from the supply voltage (PELV), but has the same ground potential as the analog and digital inputs and outputs.

Relay outputs

Programmable relay outputs	2
Relay 01 Terminal number	1-3 (break), 1-2 (make)
Max. terminal load (AC-1) ¹⁾ on 1-3 (NC), 1-2 (NO) (Resistive load)	240 V AC, 2 A
Max. terminal load (AC-15) ¹⁾ (Inductive load @ cosφ 0.4)	240 V AC, 0.2 A
Max. terminal load (DC-1) ¹⁾ on 1-2 (NO), 1-3 (NC) (Resistive load)	48 V DC, 1 A
Max. terminal load (DC-13) ¹⁾ (Inductive load)	24 V DC, 0.1 A
Relay 02 Terminal number	4-6 (break), 4-5 (make)
Max. terminal load (AC-1) ¹⁾ on 4-5 (NO) (Resistive load) ²⁾³⁾ Overvoltage cat. II	240 V AC, 2 A
Max. terminal load (AC-15) ¹⁾ on 4-5 (NO) (Inductive load @ cosφ 0.4)	240 V AC, 0.2 A
Max. terminal load (DC-1) ¹⁾ on 4-5 (NO) (Resistive load)	80 V DC, 2 A
Max. terminal load (DC-13) ¹⁾ on 4-5 (NO) (Inductive load)	24 V DC, 0.1 A
Max. terminal load (AC-1) ¹⁾ on 4-6 (NC) (Resistive load)	240 V AC, 2 A
Max. terminal load (AC-15) ¹⁾ (Inductive load @ cosφ 0.4)	240 V AC, 0.2 A
Max. terminal load (DC-1) ¹⁾ on 4-6 (NO), 4-5 (NC) (Resistive load)	48 V DC, 1 A
Max. terminal load (DC-13) ¹⁾ (Inductive load)	24 V DC, 0.1 A
Min. terminal load on 1-3 (NC), 1-2 (NO), 4-6 (NC), 4-5 (NO)	24 V DC 10 mA, 24 V AC 20 mA

1) IEC 60947 part 4 and 5

The relay contacts are galvanically isolated from the rest of the circuit by reinforced isolation (PELV).

2) Overvoltage Category II

3) UL applications 300 V AC 2A

Control card, 10 V DC output

Terminal number	±50
Output voltage	10.5 V ±0.5 V
Maximum load	15 mA

The 10 V DC supply is galvanically isolated from the supply voltage (PELV) and other high-voltage terminals.

Control characteristics

Resolution of output frequency at 0–590 Hz	±0.003 Hz
Repeat accuracy of precise start/stop (terminals 18, 19)	≤±0.1 ms
System response time (terminals 18, 19, 27, 29, 32, 33)	≤2 ms
Speed control range (open loop)	1:100 of synchronous speed
Speed control range (closed loop)	1:1000 of synchronous speed
Speed accuracy (open loop)	30–4000 RPM: error ±8 RPM
Speed accuracy (closed loop), depending on resolution of feedback device	0–6000 RPM: error ±0.15 RPM
Torque control accuracy (speed feedback)	Maximum error ±5% of rated torque

All control characteristics are based on a 4-pole asynchronous motor.

Control card performance

Scan interval	1 ms
---------------	------

Surroundings

Enclosure rating	IP66/Type 4X (indoor)
------------------	-----------------------

Vibration test for units with no circuit breaker	1.7 g RMS
--	-----------

Mounts unit with integrated circuit breaker on a level, vibration-proof and torsionally rigid support structure

Max. relative humidity	5%-95% (IEC 60 721-3-3; Class 3K3 (non-condensing) during operation
------------------------	---

Ambient temperature	Max. 40 °C (75 °F) (24-hour average maximum 35 °C (95 °F)
---------------------	---

Temperature during storage/transport	-25 to +65/70 °C (-13 to +149/158 °F)
--------------------------------------	---------------------------------------

Derating for high ambient temperature

Minimum ambient temperature during full-scale operation	0 °C (32 °F)
---	--------------

Minimum ambient temperature at reduced performance	-10 °C (14 °F)
--	----------------

Maximum altitude above sea level	1000 m (3280.8 ft)
----------------------------------	--------------------

Energy efficiency class ¹⁾	IE2
---------------------------------------	-----

Derating for high altitude

1) Determined according to EN50598-2 at:

- Rated load
- 90% rated frequency
- Switching frequency factory setting
- Switching pattern factory setting

Control card, USB serial communication

USB standard	1.1 (Full speed)
--------------	------------------

USB plug	USB type B plug
----------	-----------------

Connection to PC is carried out via a standard host/device USB cable.

The USB connection is galvanically isolated from the supply voltage (PELV) and other high-voltage terminals.

The USB ground connection is **not** galvanically isolated from protection earth. Use only an isolated laptop as PC connection to the USB connector on the frequency converter.

Index

A		Discharge time.....	4
Alarm log.....	33	Downloading data from the LCP.....	35
Alarm messages.....	63	E	
AMA.....	61	Efficiency.....	72
Analog Inputs.....	75	Electrical data.....	72
Analog output.....	76	Electronic overload.....	67
Auto mode.....	33	EMC.....	28
Auto on.....	34	Energy efficiency class.....	78
Auto On.....	61, 62	External command.....	62
Automatic Motor Adaptation (AMA).....	37	External commands.....	60
Auto-reset.....	32	F	
B		Fault log.....	33
Brake control.....	67	Feedback.....	28, 61
Braking.....	61	Fuses.....	28
C		Fusing.....	28
Cable Lengths and Cross Sections.....	74	G	
Cleaning.....	13	Ground loops.....	24
Communication option.....	68	Grounding.....	28
Conduit.....	28	H	
Control		Hand.....	61
Characteristics.....	77	Hand on.....	34
Control cables.....	24	Hand On.....	61
Control card.....	7	High voltage.....	3
Control card		I	
RS485.....	76	Initialisation.....	35
Serial communication.....	76	Input power.....	28
Control Card Performance.....	78	Installation.....	28
Control Card, 24 V DC Output.....	77	Intermediate circuit.....	67
Control card, USB serial communication.....	78	IT mains.....	20
Control signal.....	61	see also <i>Delta-grounded mains</i>	
Control terminal.....	34, 61, 62	K	
Control wiring.....	28	KTY sensor.....	67
Conventions.....	3	L	
Cooling clearance.....	28	Language package.....	36
D		LED.....	60
DC current.....	61	Load sharing.....	3
DC link.....	67	Local control.....	32, 34, 61
Default settings.....	40	Local control panel.....	32
Delta-grounded mains.....	20	Local operation.....	32
Digital input.....	62		
Digital Inputs.....	75		
Digital Output.....	76		

M

Main menu..... 33

Main reactance..... 37

Mains Supply (L1, L2, L3)..... 74

Mains voltage..... 32, 34, 61

Menu key..... 32, 33

Menu structure..... 34

Motor current..... 32

Motor frequency..... 32

Motor output..... 74

Motor power..... 32

Motor rotation..... 33

Motor wiring..... 28

N

Navigation key..... 32, 34, 61

Noise isolation..... 28

O

Operation key..... 34

Output current..... 61

Output Performance (U, V, W)..... 74

Overcurrent..... 62

Overvoltage..... 62

P

Parameter setting..... 34

Power factor..... 28

Programming..... 32, 33, 34

Protection and Features..... 74

Pulse/Encoder Inputs..... 76

Q

Quick menu..... 33

R

Reference..... 32, 61, 62

Relay Outputs..... 77

Remote reference..... 61

Reset..... 32, 34, 35, 62

Restore..... 35

Restoring default setting..... 35

Restoring Default Settings..... 35

RS485..... 76

Run permissive..... 61

S

Screened cable..... 28

Screened Control Cables..... 24

Serial communication..... 24, 34, 61, 62, 78

Serial communication
RS485..... 76

Setpoint..... 62

Set-up..... 33

Sleep mode..... 62

Speed reference..... 61

Start-up..... 35

Stator leakage reactance..... 37

Status mode..... 60

Stop command..... 62

Surroundings..... 78

Switching frequency..... 62

T

Torque Characteristics..... 74

U

Unintended start..... 3, 35

Uploading data to the LCP..... 35

V

Voltage level..... 75

W

Warnings..... 63



.....
Danfoss can accept no responsibility for possible errors in catalogues, brochures and other printed material. Danfoss reserves the right to alter its products without notice. This also applies to products already on order provided that such alterations can be made without subsequential changes being necessary in specifications already agreed. All trademarks in this material are property of the respective companies. Danfoss and the Danfoss logotype are trademarks of Danfoss A/S. All rights reserved.
.....

Danfoss A/S
Ulsnaes 1
DK-6300 Graasten
vlt-drives.danfoss.com

