



Programming Guide

VLT® AutomationDrive FC 360

Contents

| | |
|---|-----------|
| 1 Introduction | 3 |
| 1.1.1 Abbreviations | 3 |
| 1.1.2 Definitions | 4 |
| 1.1.3 Electrical Wiring - Control Cables | 8 |
| 2 How to Programme | 11 |
| 2.1 Programming | 11 |
| 2.1.1 Programming with the Numerical Local Control Panel (NLCP) | 11 |
| 2.1.2 LCP 21 | 11 |
| 2.1.3 The Right-Key Function | 12 |
| 2.2 Quick Menu | 13 |
| 2.3 Status Menu | 15 |
| 2.4 Main Menu | 15 |
| 3 Parameter Descriptions | 17 |
| 3.1 Parameters: 0-** Operation and Display | 17 |
| 3.2 Parameters: 1-** Load and Motor | 21 |
| 3.2.1 1-0* General Settings | 21 |
| 3.2.2 1-2* Motor Data | 22 |
| 3.3 Parameters: 2-** Brakes | 27 |
| 3.4 Parameters: 3-** Reference/Ramps | 29 |
| 3.4.1 3-0* Reference Limits | 29 |
| 3.4.3 3-4* Ramp 1 | 31 |
| 3.4.4 3-5* Ramp 2 | 32 |
| 3.4.5 3-8* Other Ramps | 32 |
| 3.5 Parameters: 4-** Limits/Warnings | 34 |
| 3.6 Parameters: 5-** Digital In/Out | 37 |
| 3.6.1 5-0* Digital I/O Mode | 37 |
| 3.6.4 5-4* Relays | 41 |
| 3.6.8 5-9* Bus Controlled | 46 |
| 3.7 Parameters: 6-** Analog In/Out | 47 |
| 3.7.1 6-0* Analog I/O Mode | 47 |
| 3.7.2 6-1* Analog Input 53 | 47 |
| 3.7.3 6-2* Analog Input 54 | 48 |
| 3.7.4 6-7* Analog/Digital Output 45 | 48 |
| 3.7.5 6-9* Analog/Digital Output 42 | 50 |
| 3.8 Parameters: 7-** Controllers | 52 |
| 3.9 Parameters: 8-** Communications and Options | 57 |
| 3.10 Parameters: 13-** Smart Logic Control | 61 |
| 3.11 Parameters: 14-** Special Functions | 68 |

| | |
|---|------------|
| 3.11.3 14-2* Trip Reset | 70 |
| 3.12 Parameters: 15-** Drive Information | 73 |
| 3.13 Parameters: 16-** Data Read-outs | 75 |
| 3.14 Parameters: 18-** Data Readouts 2 | 78 |
| 3.15 Parameters: 22-** Application Functions | 79 |
| 3.15.1 22-4* Sleep Mode | 79 |
| 3.15.2 22-6* Broken Belt Detection | 80 |
| 3.16 Parameters: 30-** Special Features | 80 |
| 4 Parameter Lists | 81 |
| 4.1.1 Conversion | 82 |
| 4.1.2 Active/Inactive Parameters in Different Drive Control Modes | 82 |
| 4.1.3 0-** Operation and Display | 85 |
| 4.1.4 1-** Load and Motor | 86 |
| 4.1.5 2-** Brakes | 87 |
| 4.1.6 3-** Reference/Ramps | 87 |
| 4.1.7 4-** Limits/Warnings | 88 |
| 4.1.8 5-** Digital In/Out | 89 |
| 4.1.9 6-** Analog In/Out | 90 |
| 4.1.10 7-** Controllers | 91 |
| 4.1.11 8-** Communications and Options | 92 |
| 4.1.12 13-** Smart Logic Control | 93 |
| 4.1.13 14-** Special Functions | 94 |
| 4.1.14 15-** Drive Information | 95 |
| 4.1.15 16-** Data Read-outs | 96 |
| 4.1.16 18-** Data Readouts 2 | 97 |
| 4.1.17 22-** Application Functions | 97 |
| 5 Troubleshooting | 98 |
| 5.1 Warnings and Alarms | 98 |
| 5.1.1 Alarms | 98 |
| 5.1.2 Warnings | 98 |
| 5.1.3 Warning/Alarm Messages | 99 |
| Index | 104 |

1 Introduction

Programming Guide
Software version: 1.0x

This Programming Guide can be used for all FC 360 frequency converters with software version 1.0x.
The software version number can be seen from *15-43 Software Version*.

Symbols

The following symbols are used in this manual.



Indicates a potentially hazardous situation which, if not avoided, could result in death or serious injury.



Indicates a potentially hazardous situation which, if not avoided, may result in minor or moderate injury. It may also be used to alert against unsafe practices.

CAUTION

Indicates a situation that may result in equipment or property-damage-only accidents.

NOTE

Indicates highlighted information that should be regarded with attention to avoid mistakes or operate equipment at less than optimal performance.



Table 1.1 Approval

1.1.1 Abbreviations

| | |
|--|----------------------|
| Alternating current | AC |
| American wire gauge | AWG |
| Ampere/AMP | A |
| Automatic Motor Adaptation | AMA |
| Current limit | I _{LIM} |
| Degrees Celsius | °C |
| Direct current | DC |
| Drive Dependent | D-TYPE |
| Electro Magnetic Compatibility | EMC |
| Electronic Thermal Relay | ETR |
| Frequency converter | FC |
| Gram | g |
| Hertz | Hz |
| Horsepower | hp |
| Kilohertz | kHz |
| Local Control Panel | LCP |
| Meter | m |
| Millihenry Inductance | mH |
| Milliamper | mA |
| Millisecond | ms |
| Minute | min |
| Motion Control Tool | MCT |
| Nanofarad | nF |
| Newton Meters | Nm |
| Nominal motor current | I _{M,N} |
| Nominal motor frequency | f _{M,N} |
| Nominal motor power | P _{M,N} |
| Nominal motor voltage | U _{M,N} |
| Permanent Magnet motor | PM motor |
| Protective Extra Low Voltage | PELV |
| Printed Circuit Board | PCB |
| Rated Inverter Output Current | I _{INV} |
| Revolutions Per Minute | RPM |
| Regenerative terminals | Regen |
| Second | s |
| Synchronous Motor Speed | n _s |
| Torque limit | T _{LIM} |
| Volts | V |
| The maximum output current | I _{VLT,MAX} |
| The rated output current supplied by the frequency converter | I _{VLT,N} |

Table 1.2 Abbreviations

1.1.2 Definitions

Frequency converter

$I_{VLT, MAX}$

Maximum output current.

$I_{VLT, N}$

Rated output current supplied by the frequency converter.

$U_{VLT, MAX}$

Maximum output voltage.

Input

Control command

Start and stop the connected motor by means of LCP and digital inputs.

Functions are divided into two groups.

Functions in group 1 have higher priority than functions in group 2.

| | |
|---------|--|
| Group 1 | Reset, Coasting stop, Reset and Coasting stop, Quick-stop, DC braking, Stop and the [OFF] key. |
| Group 2 | Start, Pulse start, Reversing, Start reversing, Jog and Freeze output |

Motor

Motor Running

Torque generated on output shaft and speed from zero rpm to max. speed on motor.

f_{JOG}

Motor frequency when the jog function is activated (via digital terminals).

f_M

Motor frequency.

f_{MAX}

Maximum motor frequency.

f_{MIN}

Minimum motor frequency.

$f_{M,N}$

Rated motor frequency (nameplate data).

I_M

Motor current (actual).

$I_{M,N}$

Rated motor current (nameplate data).

$n_{M,N}$

Rated motor speed (nameplate data).

n_s

Synchronous motor speed

$$n_s = \frac{2 \times par. 1 - 23 \times 60 s}{par. 1 - 39}$$

n_{slip}

Motor slip.

$P_{M,N}$

Rated motor power (nameplate data in kW or HP).

$T_{M,N}$

Rated torque (motor).

U_M

Instantaneous motor voltage.

$U_{M,N}$

Rated motor voltage (nameplate data).

Break-away torque

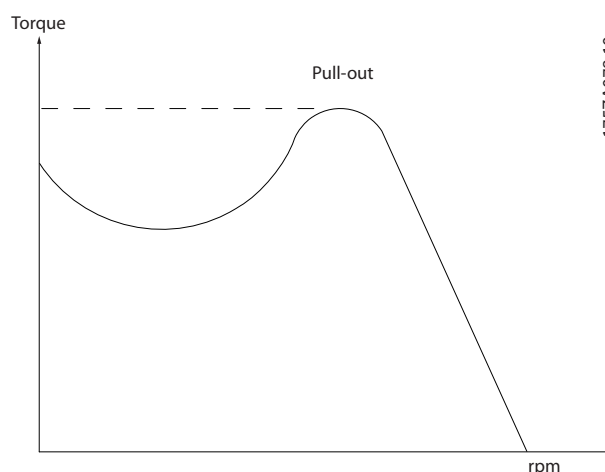

175ZA078.10

Illustration 1.1 Break-away torque

η_{VLT}

The efficiency of the frequency converter is defined as the ratio between the power output and the power input.

Start-disable command

A stop command belonging to the group 1 control commands - see this group.

Stop command

See Control commands.

References

Analog Reference

A signal transmitted to the analog inputs 53 or 54, can be voltage or current.

Binary Reference

A signal transmitted to the serial communication port.

Preset Reference

A defined preset reference to be set from -100% to +100% of the reference range. Selection of eight preset references via the digital terminals.

Pulse Reference

A pulse frequency signal transmitted to the digital inputs (terminal 29 or 33).

Ref_{MAX}

Determines the relationship between the reference input at 100% full scale value (typically 10 V, 20 mA) and the resulting reference. The maximum reference value set in 3-03 *Maximum Reference*.

Ref_{MIN}

Determines the relationship between the reference input at 0% value (typically 0 V, 0 mA, 4 mA) and the resulting reference. The minimum reference value set in 3-02 *Minimum Reference*.

MiscellaneousAnalog Inputs

The analog inputs are used for controlling various functions of the frequency converter.

There are two types of analog inputs:

Current input, 0-20 mA and 4-20 mA

Voltage input, 0 to +10 V DC.

Analog Outputs

The analog outputs can supply a signal of 0-20 mA, 4-20 mA.

Automatic Motor Adaptation, AMA

AMA algorithm determines the electrical parameters for the connected motor at standstill.

Brake Resistor

The brake resistor is a module capable of absorbing the brake power generated in regenerative braking. This regenerative braking power increases the intermediate circuit voltage and a brake chopper ensures that the power is transmitted to the brake resistor.

CT Characteristics

Constant torque characteristics used for all applications such as conveyor belts, displacement pumps and cranes.

Digital Inputs

The digital inputs can be used for controlling various functions of the frequency converter.

Digital Outputs

The frequency converter features two Solid State outputs that can supply a 24 V DC (max. 40 mA) signal.

DSP

Digital Signal Processor.

ETR

Electronic Thermal Relay is a thermal load calculation based on present load and time. Its purpose is to estimate the motor temperature.

Hiperface®

Hiperface® is a registered trademark by Stegmann.

Initialising

If initialising is carried out (*14-22 Operation Mode*), the frequency converter returns to the default setting.

Intermittent Duty Cycle

An intermittent duty rating refers to a sequence of duty cycles. Each cycle consists of an on-load and an off-load period. The operation can be either periodic duty or non-periodic duty.

LCP

The Local Control Panel makes up a complete interface for control and programming of the frequency converter. The control panel is detachable and can be installed up to 3 m from the frequency converter, i.e. in a front panel with the installation kit option.

lsb

Least significant bit.

msb

Most significant bit.

MCM

Short for Mille Circular Mil, an American measuring unit for cable cross-section. 1 MCM = 0.5067mm².

On-line/Off-line Parameters

Changes to on-line parameters are activated immediately after the data value is changed. Changes to off-line parameters are not activated until you enter [OK] on the LCP.

Process PID

The PID control maintains the desired speed, pressure, temperature, etc. by adjusting the output frequency to match the varying load.

PCD

Process Control Data

Power Cycle

Switch off the mains until display (LCP) is dark – then turn power on again.

Pulse Input/Incremental Encoder

An external, digital pulse transmitter used for feeding back information on motor speed. The encoder is used in applications where great accuracy in speed control is required.

RCD

Residual Current Device.

Set-up

Save parameter settings in two Set-ups. Change between the two parameter Set-ups and edit one Set-up, while another Set-up is active.

SFAVM

Switching pattern called Stator Flux oriented Asynchronous Vector Modulation (*14-00 Switching Pattern*).

Slip Compensation

The frequency converter compensates for the motor slip by giving the frequency a supplement that follows the

measured motor load keeping the motor speed almost constant.

Smart Logic Control (SLC)

The SLC is a sequence of user defined actions executed when the associated user defined events are evaluated as true by the Smart Logic Controller. (Parameter group 13-** *Smart Logic Control (SLC)*).

STW

Status Word

FC Standard Bus

Includes RS-485 bus with FC protocol or MC protocol. See 8-30 *Protocol*.

Thermistor

A temperature-dependent resistor placed where the temperature is to be monitored (frequency converter or motor).

Trip

A state entered in fault situations, e.g. if the frequency converter is subject to an over-temperature or when the frequency converter is protecting the motor, process or mechanism. Restart is prevented until the cause of the fault has disappeared and the trip state is cancelled by activating reset or, in some cases, by being programmed to reset automatically. Trip may not be used for personal safety.

Trip Locked

A state entered in fault situations when the frequency converter is protecting itself and requiring physical intervention, e.g. if the frequency converter is subject to a short circuit on the output. A locked trip can only be cancelled by cutting off mains, removing the cause of the fault, and reconnecting the frequency converter. Restart is prevented until the trip state is cancelled by activating reset or, in some cases, by being programmed to reset automatically. Trip may not be used for personal safety.

VT Characteristics

Variable torque characteristics used for pumps and fans.

VVC^{plus}

If compared with standard voltage/frequency ratio control, Voltage Vector Control (VVC^{plus}) improves the dynamics and the stability, both when the speed reference is changed and in relation to the load torque.

60° AVM

Switching pattern called 60° Asynchronous Vector Modulation (14-00 *Switching Pattern*).

Power Factor

The power factor is the relation between I_1 and I_{RMS} .

$$\text{Power factor} = \frac{\sqrt{3} \times U \times I_1 \cos\varphi}{\sqrt{3} \times U \times I_{RMS}}$$

The power factor for 3-phase control:

$$= \frac{I_1 \times \cos\varphi}{I_{RMS}} = \frac{I_1}{I_{RMS}} \text{ since } \cos\varphi = 1$$

The power factor indicates to which extent the frequency converter imposes a load on the mains supply.

The lower the power factor, the higher the I_{RMS} for the same kW performance.

$$I_{RMS} = \sqrt{I_1^2 + I_2^2 + I_3^2 + \dots + I_n^2}$$

In addition, a high power factor indicates that the different harmonic currents are low.

The frequency converters' built-in DC coils produce a high power factor, which minimizes the imposed load on the mains supply.

WARNING

The voltage of the frequency converter is dangerous whenever connected to mains. Incorrect installation of the motor, frequency converter or fieldbus may cause death, serious personal injury or damage to the equipment. Consequently, the instructions in this manual, as well as national and local rules and safety regulations, must be complied with.

Safety Regulations

1. The mains supply to the frequency converter must be disconnected whenever repair work is to be carried out. Check that the mains supply has been disconnected and that the necessary time has elapsed before removing motor and mains supply cables.
2. [Off] does not disconnect the mains supply and consequently it must not be used as a safety switch.
3. The equipment must be properly earthed, the user must be protected against supply voltage and the motor must be protected against overload in accordance with applicable national and local regulations.
4. The earth leakage current exceeds 3.5 mA.
5. Protection against motor overload is not included in the factory setting. If this function is desired, set 1-90 *Motor Thermal Protection* to data value [4] *ETR trip 1* or data value [3] *ETR warning 1*.
6. The frequency converter has more voltage sources than L1, L2 and L3, when load sharing (linking of DC intermediate circuit) is installed. Check that all voltage sources have been disconnected and that the necessary time has elapsed before commencing repair work.

Warning against unintended start

1. The motor can be brought to a stop by means of digital commands, bus commands, references or a local stop, while the frequency converter is connected to mains. If personal safety considerations (e.g. risk of personal injury caused by contact with moving machine parts following an unintentional start) make it necessary to ensure that no unintended start occurs, these stop functions are not sufficient. In such cases the mains supply must be disconnected.
2. The motor may start while setting the parameters. If this means that personal safety may be compromised (e.g. personal injury caused by contact with moving machine parts), motor starting must be prevented by disconnection of the motor connection.
3. A motor that has been stopped with the mains supply connected, may start if faults occur in the electronics of the frequency converter, through temporary overload or if a fault in the power supply grid or motor connection is remedied. If unintended start must be prevented for personal safety reasons (e.g. risk of injury caused by contact with moving machine parts), the normal stop functions of the frequency converter are not sufficient. In such cases the mains supply must be disconnected.
4. Control signals from, or internally within, the frequency converter may in rare cases be activated in error, be delayed or fail to occur entirely. When used in situations where safety is critical, e.g. when controlling the electromagnetic brake function of a hoist application, these control signals must not be relied on exclusively.

⚠ WARNING**High Voltage**

Touching the electrical parts may be fatal - even after the equipment has been disconnected from mains.

Also make sure that other voltage inputs have been disconnected, such as load sharing (linkage of DC intermediate circuit), as well as the motor connection for kinetic back up.

Systems where frequency converters are installed must, if necessary, be equipped with additional monitoring and protective devices according to the valid safety regulations, e.g. law on mechanical tools, regulations for the prevention of accidents etc. Modifications on the frequency converters by means of the operating software are allowed.

NOTE

Hazardous situations shall be identified by the machine builder/ integrator who is responsible for taking necessary preventive means into consideration. Additional monitoring and protective devices may be included, always according to valid national safety regulations, e.g. law on mechanical tools, regulations for the prevention of accidents.

Protection Mode

Once a hardware limit on motor current or dc-link voltage is exceeded the frequency converter will enter "Protection mode". "Protection mode" means a change of the PWM modulation strategy and a low switching frequency to minimize losses. This continues 10 s after the last fault and increases the reliability and the robustness of the frequency converter while re-establishing full control of the motor.

1.1.3 Electrical Wiring - Control Cables

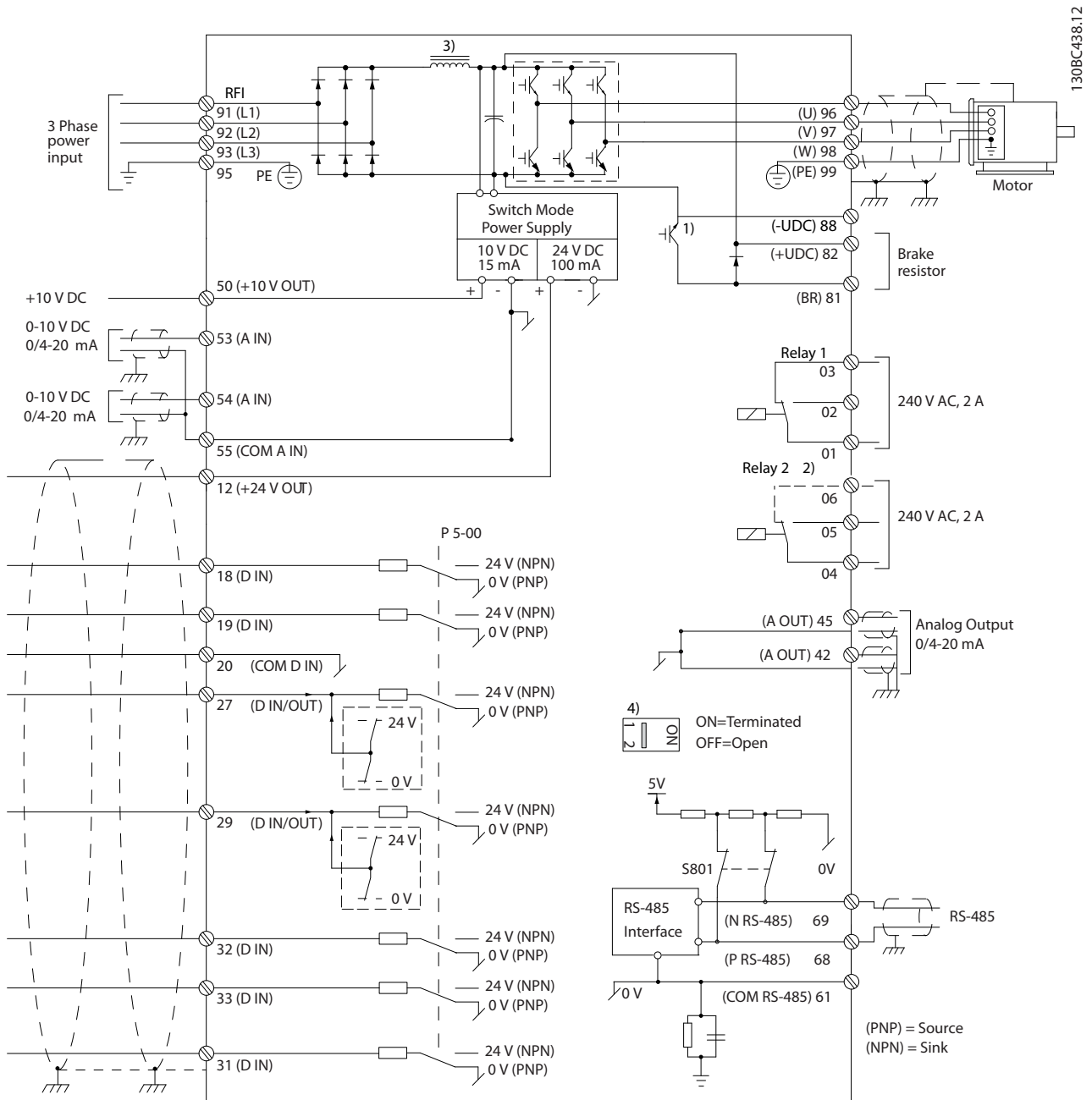

Illustration 1.2 Basic Wiring Schematic Drawing

A=Analog, D=Digital

- 1) Built-in braking chopper available from 0.37 - 22 kW
- 2) Relay 2 is 2 pole for J1-J3 and 3 pole for J4-J7. Relay 2 of J4-J7 with terminal 4,5,6, same NO/NC logic as Relay 1
- 3) Dual DC choke in 30-75 kW
- 4) Switch S801 (bus terminal) can be used to enable termination on the RS-485 port (terminals 68 and 69)

Very long control cables and analog signals may in rare cases and depending on installation result in 50/60 Hz earth loops due to noise from mains supply cables.

If this occurs, it may be necessary to break the screen or insert a 100 nF capacitor between screen and chassis.

The digital and analog inputs and outputs must be connected separately to the common inputs (terminal 20 and 55) of the frequency converter to avoid ground currents from both groups to affect other groups. For example, switching on the digital input may disturb the analog input signal.

Input polarity of control terminals

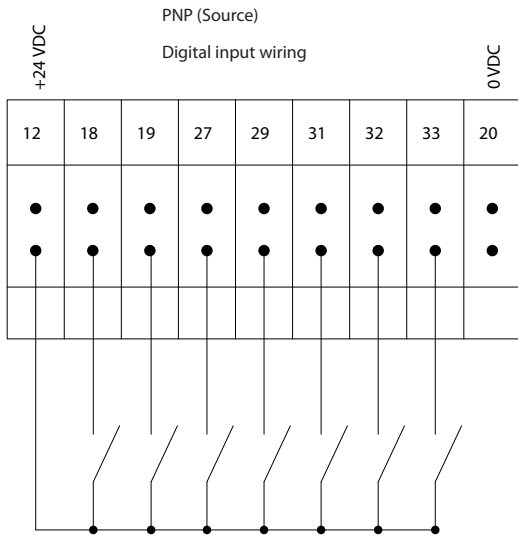
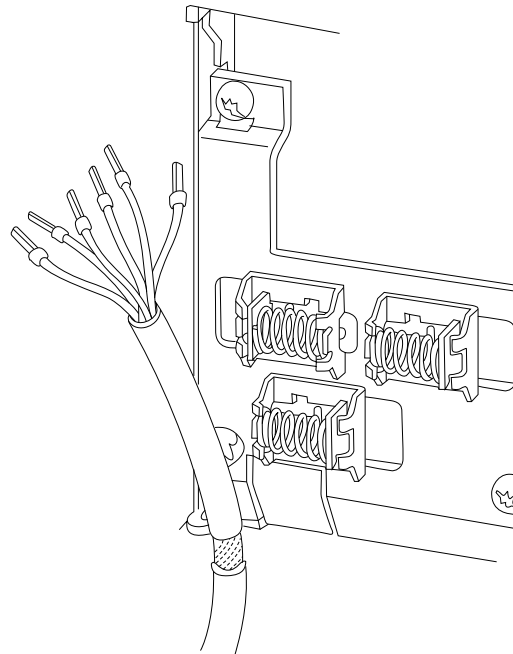

Illustration 1.3 PNP (Source)

130BD367.10



130BA681.10

Illustration 1.5 Earthing of Screened/Armoured Control Cables

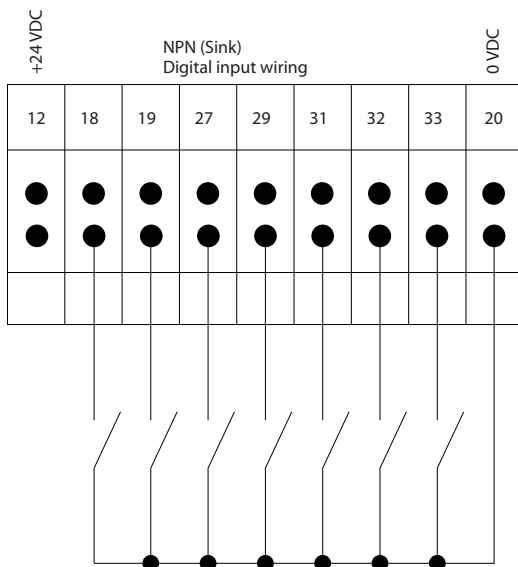
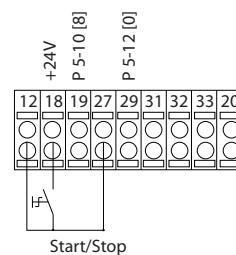

Illustration 1.4 NPN (Sink)

130BD368.11

1.1.4 Start/Stop

Terminal 18 = 5-10 Terminal 18 Digital Input [8] Start
 Terminal 27 = 5-12 Terminal 27 Digital Input [0] No operation (Default coast inverse)



130BD369.10

NOTE

Control cables must be screened/armoured.

See section on earthing of screened/armoured control cables in the Design Guide for the correct termination of control cables.

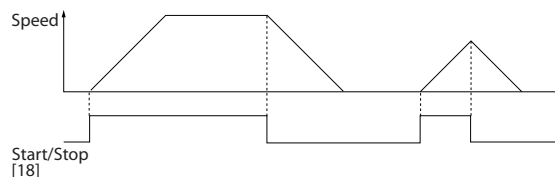

Illustration 1.6 Start/Stop

1.1.5 Pulse Start/Stop

Terminal 18 = 5-10 Terminal 18 Digital Input Latched start, [9]

Terminal 27 = 5-12 Terminal 27 Digital Input Stop inverse, [6]

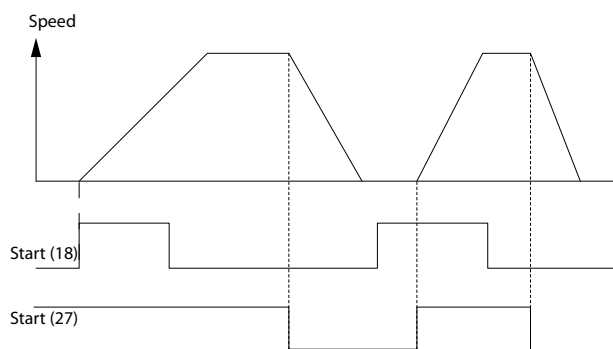
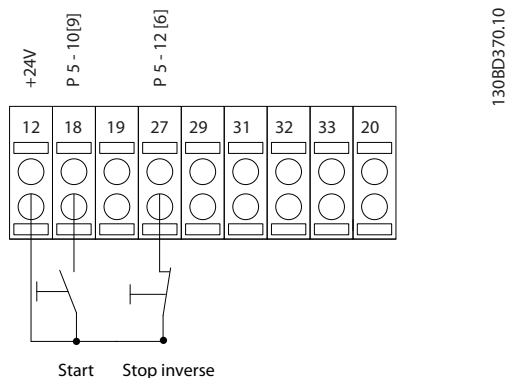

Illustration 1.7 Pulse Start/Stop

1.1.6 Speed Up/Down

Terminals 29/32 = Speed up/down

Terminal 18 = 5-10 Terminal 18 Digital Input Start [9] (default)

Terminal 27 = 5-12 Terminal 27 Digital Input Freeze reference [19]

Terminal 29 = 5-13 Terminal 29 Digital Input Speed up [21]

Terminal 32 = 5-14 Terminal 32 Digital Input Speed down [22]

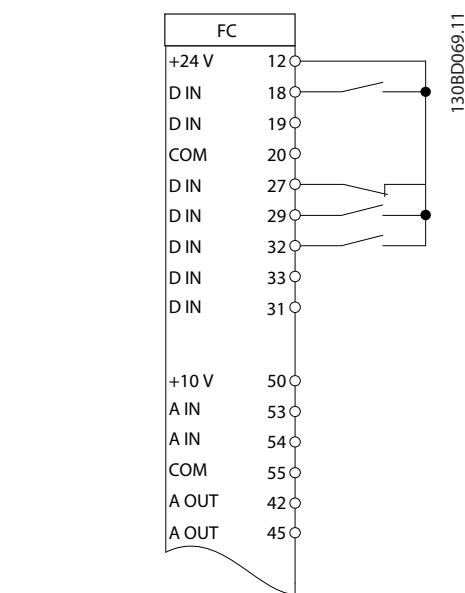

Illustration 1.8 Speed Up/Down

1.1.7 Potentiometer Reference

Voltage reference via a potentiometer

Reference Source 1 = [1] Analog input 53 (default)

Terminal 53, Low Voltage = 0 V

Terminal 53, High Voltage = 10 V

Terminal 53, Low Ref./Feedback = 0 RPM

Terminal 53, High Ref./Feedback = 1500 RPM

6-19 Terminal 53 mode=[1] Voltage

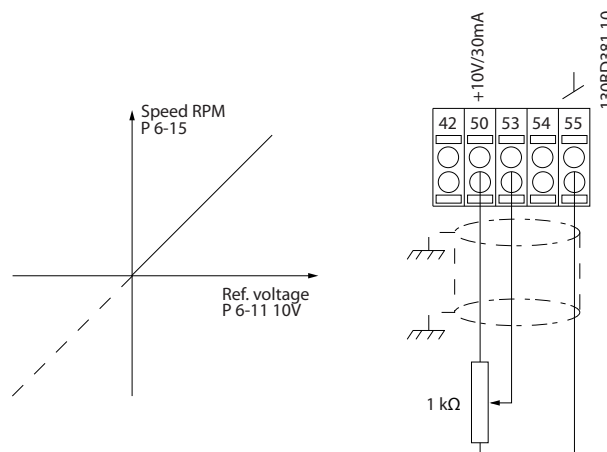

Illustration 1.9 Potentiometer Reference

2 How to Programme

2.1 Programming

2.1.1 Programming with the Numerical Local Control Panel (NLCP)

The FC 360 supports graphic and numerical local control panels as well as blind covers. This chapter covers programming with the NLCP.

NOTE

The frequency converter can also be programmed from a PC via RS-485 com-port by installing the MCT-10 Setup software. This software can either be ordered using code number 130B1000 or downloaded from the Danfoss Web site: www.danfoss.com/BusinessAreas/DrivesSolutions/softwaredownload.

2.1.2 LCP 21

The LCP 21 is divided into four functional sections.

- A. Numeric display
- B. Menu key
- C. Navigation keys and indicator lights (LEDs)
- D. Operation keys and indicator lights (LEDs)

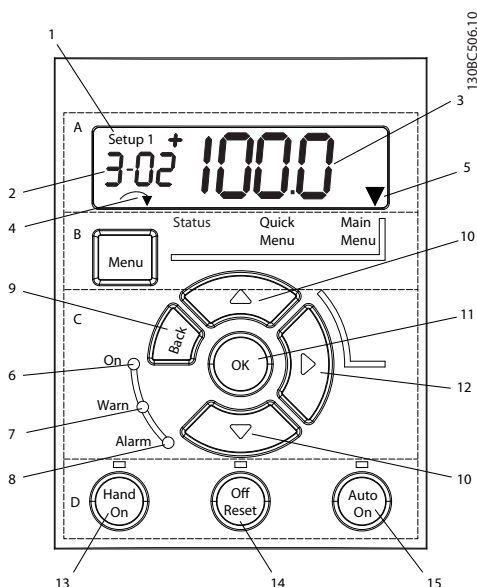

Illustration 2.1 View of the LCP 21

A. Numeric Display

The LCD-display is back-lit with 1 numeric line. All data is displayed in the LCP.

| | |
|---|--|
| 1 | Set-up number shows the active set-up and the edit set-up. If the same set-up acts as both active and edit set-up, only that set-up number is shown (factory setting). When active and edit set-up differ, both numbers are shown in the display (Setup 12). The number flashing, indicates the edit set-up. |
| 2 | Parameter number. |
| 3 | Parameter value. |
| 4 | Motor direction is shown to the bottom left of the display – indicated by a small arrow pointing either clockwise or counterclockwise. |
| 5 | The triangle indicates if the LCP is in status, quick menu or main menu. |

Table 2.1 Legend to Illustration 2.1



Illustration 2.2 Display Information

B. Menu Key

Press [Menu] to select between status, quick menu or main menu.

C. Navigation keys and indicator lights (LEDs)

| | |
|----|---|
| 6 | Green LED/On: Control section is working. |
| 7 | Yellow LED/Warn.: Indicates a warning. |
| 8 | Flashing Red LED/Alarm: Indicates an alarm. |
| 9 | [Back]: For moving to the previous step or layer in the navigation structure |
| 10 | Arrows [▲] [▼]: For maneuvering between parameter groups, parameters and within parameters or increasing/decreasing parameter values. Can also be used for setting local reference. |
| 11 | [OK]: For selecting a parameter and for accepting changes to parameter settings |
| 12 | [▶]: For moving from left to right within the parameter value in order to change each digit individually. See description in 2.1.3 The Right-Key Function. |

Table 2.2 Legend to Illustration 2.1

2

D. Operation keys and indicator lights (LEDs)

| | |
|----|---|
| 13 | [Hand On]: Starts the motor and enables control of the frequency converter via the LCP. NOTE 5-12 Terminal 27 Digital Input has coast inverse as default setting. This means that [Hand On] will not start the motor if there is no 24 V to terminal 27. |
| 14 | [Off/Reset]: stops the motor (off). If in alarm mode the alarm will be reset. |
| 15 | [Auto On]: frequency converter is controlled either via control terminals or serial communication. |

Table 2.3 Legend to Illustration 2.1

2.1.3 The Right-Key Function

WARNING

The [Off/Reset] key is not a safety switch. It does not disconnect the frequency converter from mains.

Press [▶] to edit any of the four digits on the display individually. When pressing [▶] once, the cursor moves to the first digit and the digit starts flashing as shown in Illustration 2.3. Press the [▲] [▼] to change the value. Pressing [▶] will not change the value of the digits or move the decimal point.

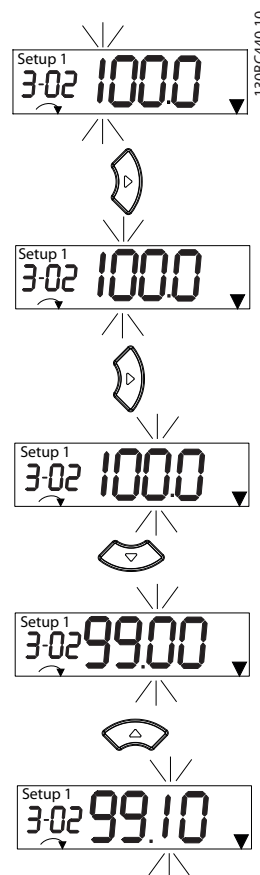

Illustration 2.3 Right Key Function

[▶] can also be used for moving between parameter groups: when in main menu, press the right key to move to the first parameter in the next parameter group (e.g. move from 0-03 Regional Settings [0] International to 1-00 Configuration Mode [0] Open loop).

2.2 Quick Menu

The Quick Menu gives easy access to the most frequently used parameters.

1. To enter the Quick Menu, press [Menu] until indicator in display is placed above *Quick Menu*.
2. Press [▲] [▼] to select either QM1 or QM2, then press [OK].
3. Press [▲] [▼] to browse through the parameters in the Quick Menu.
4. Press [OK] to select a parameter.
5. Press [▲] [▼] to change the value of a parameter setting.
6. Press [OK] to accept the change.
7. To exit, press either [Back] twice (or three times if in QM" and QM3) to enter *Status*, or press [Menu] once to enter *Main Menu*.

130BC445.11

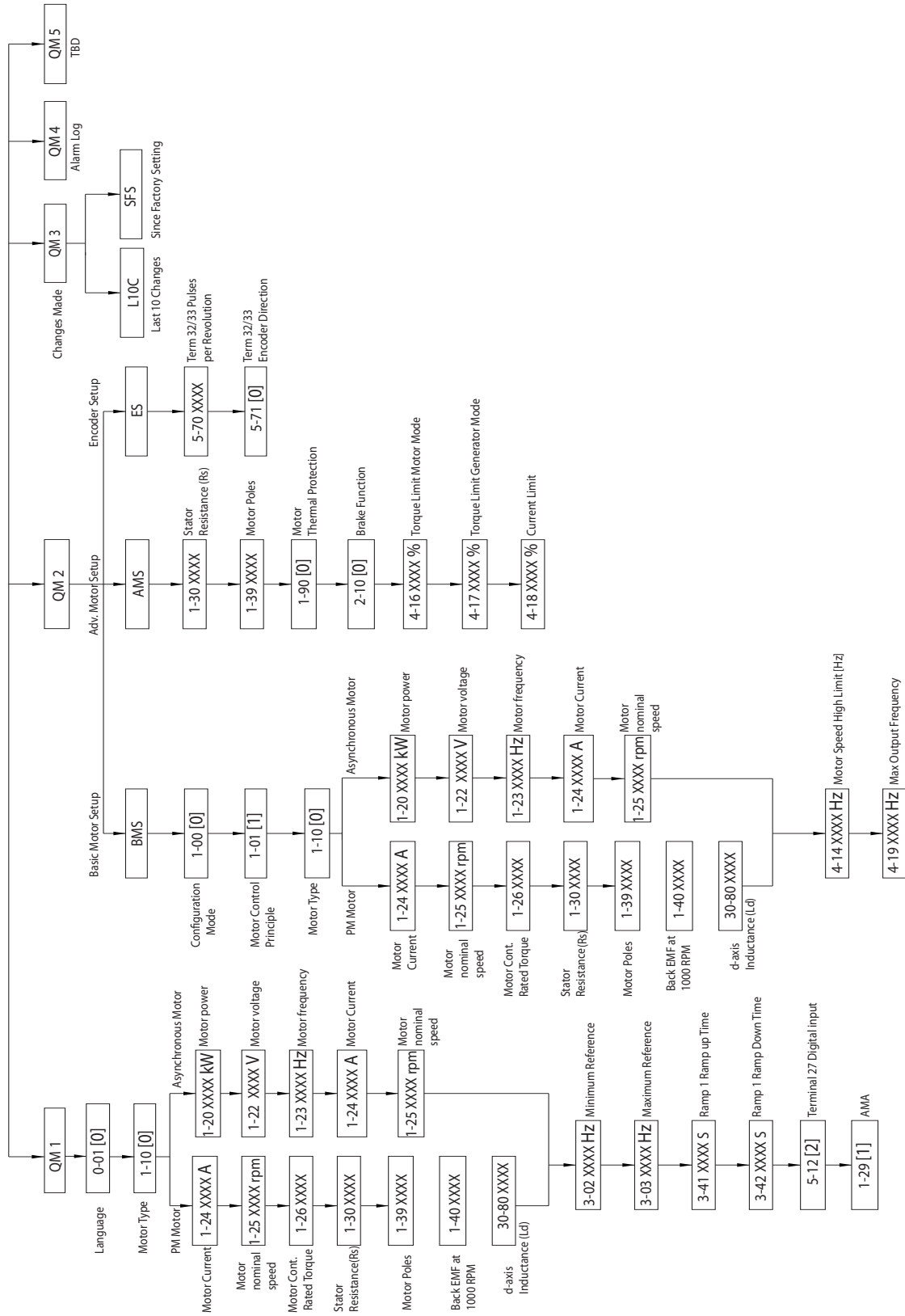

Illustration 2.4 Quick Menu Structure

2.3 Status Menu

After power up the Status Menu is active. Press [Menu] to toggle between Status, Quick Menu and Main Menu.

[▲] and [▼] toggle between the choices in each menu.

The display indicates the status mode with a small arrow above "Status".



Illustration 2.5 Indicating Status Mode

2.4 Main Menu

The Main Menu gives access to all parameters.

1. To enter the Main Menu, press [Menu] until indicator in display is placed above Main Menu.
2. [▲] [▼]: browse through the parameter groups.
3. Press [OK] to select a parameter group.
4. [▲] [▼]: browse through the parameters in the specific group.
5. Press [OK] to select the parameter.
6. [▶] and [▲] [▼]: set/change the parameter value.
7. Press [OK] to accept the value.
8. To exit, press either [Back] twice (or three times for array parameters) to enter Main Menu, or press [Menu] once to enter Status.

See *Illustration 2.6* for the principles of changing the value of continuous, enumerated and array parameters.

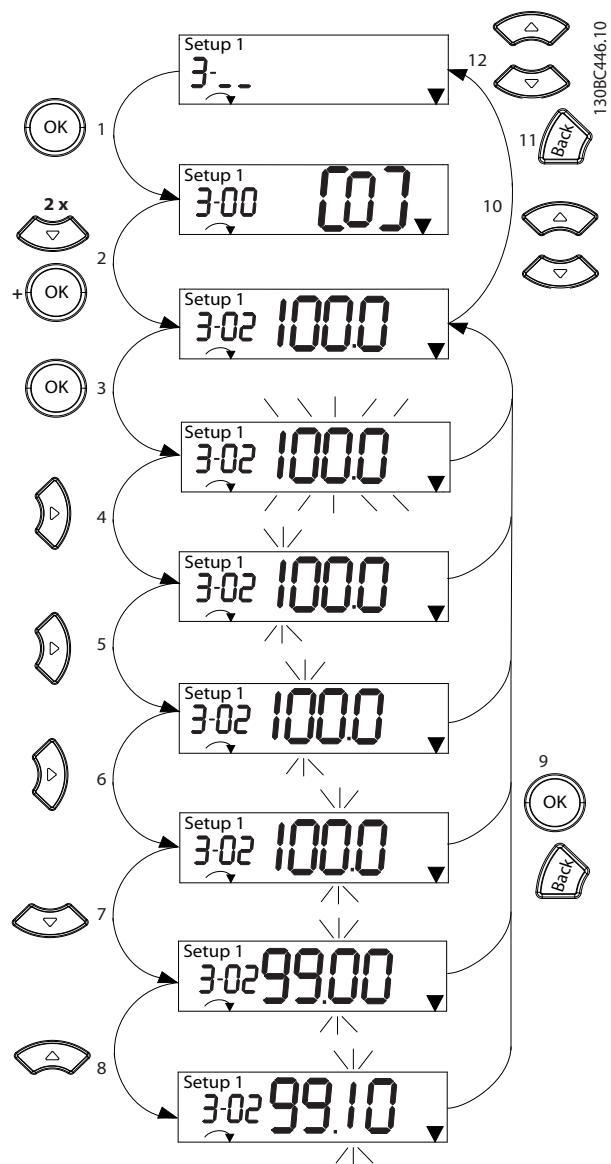

Illustration 2.6 Main Menu Interactions - Continuous Parameters

| | |
|----|---|
| 1 | [OK]: The first parameter in the group is shown. |
| 2 | Press [▼] repeatedly to move down to the desired parameter. |
| 3 | Press [OK] to start editing. |
| 4 | [▶]: First digit flashing (can be edited). |
| 5 | [▶]: Second digit flashing (can be edited). |
| 6 | [▶]: Third digit flashing (can be edited). |
| 7 | [▼]: Decreases the parameter value, the decimal point changes automatically |
| 8 | [▲]: Increases the parameter value. |
| 9 | [Back]: Cancel changes, return to 2) [OK]: Accept changes, return to 2) |
| 10 | [▲][▼]: Select parameter within the group. |
| 11 | [Back]: Removes the value and shows the parameter group. |
| 12 | [▲][▼]: Select group. |

Table 2.4 Changing Values in Continuous Parameters

For enumerated parameters the interaction is similar but the parameter value is shown in brackets, because of the LCP 21 digits limitation (4 large digits) and the enum can be greater than 99. When the enum value is greater than 99, the LCP 21 can only display the first part of the bracket.

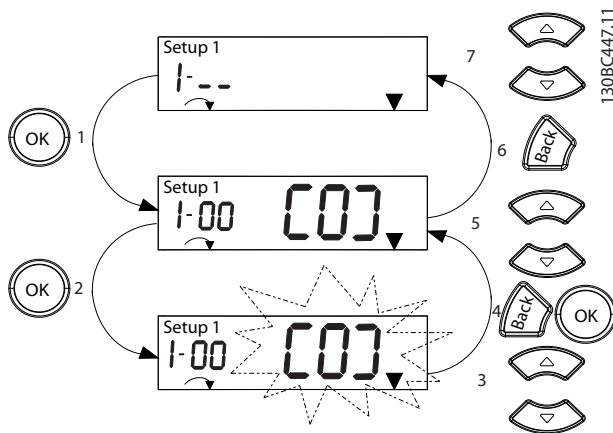

Illustration 2.7 Main Menu Interactions - Enumerated Parameters

| | |
|---|--|
| 1 | [OK]: The first parameter in the group is shown. |
| 2 | Press [OK] to start editing. |
| 3 | [▲][▼]: Change parameter value (flashing). |
| 4 | Press [Back] to cancel changes or [OK] to accept changes (return to screen 2). |
| 5 | [▲][▼]: Select parameter within the group. |
| 6 | [Back]: Removes the value and shows the parameter group. |
| 7 | [▲][▼]: Select group. |

Table 2.5 Changing Values in Enumerated Parameters

Array parameters function as follows:

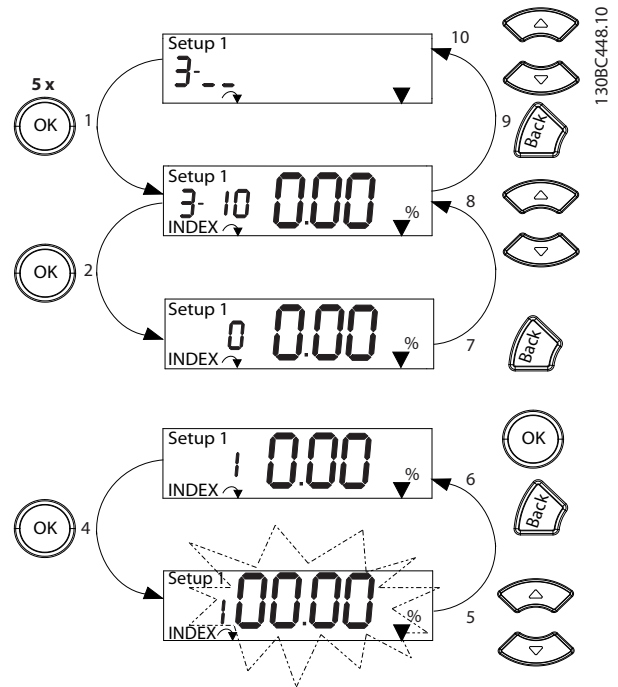

Illustration 2.8 Main Menu Interactions - Array Parameters

| | |
|----|--|
| 1 | [OK]: Shows parameter numbers and the value in the first index. |
| 2 | [OK]: Index can be selected. |
| 3 | [▲][▼]: Select index. |
| 4 | [OK]: Value can be edited. |
| 5 | [▲][▼]: Change parameter value (flashing). |
| 6 | [Back]: Cancels changes [OK]: Accepts changes |
| 7 | [Back]: Cancels editing index, a new parameter can be selected. |
| 8 | [▲][▼]: Select parameter within the group. |
| 9 | [Back]: Removes parameter index value and shows the parameter group. |
| 10 | [▲][▼]: Select group. |

Table 2.6 Changing Values in Array Parameters

3 Parameter Descriptions

3.1 Parameters: 0-** Operation and Display

Parameters related to the fundamental functions of the frequency converter, function of the LCP keys and configuration of the LCP display.

3.1.1 0-0* Basic Settings

| 0-03 Regional Settings | | |
|------------------------|---------------|--|
| Option: | Function: | |
| | | NOTE This parameter cannot be adjusted while the motor is running. |
| [0] | International | Activates 1-20 Motor Power [kW] for setting the motor power in kW and sets the default value of 1-23 Motor Frequency to 50 Hz. |
| [1] | US | Activates 1-20 Motor Power [kW] for setting the motor power in HP and sets the default value of 1-23 Motor Frequency to 60 Hz. |

| 0-04 Operating State at Power-up (Hand) | | |
|---|----------------------|--|
| Option: | Function: | |
| | | Selects the operating mode upon reconnection of the frequency converter to mains voltage after power down in Hand (local) operation mode. |
| [0] | Resume | Restarts the frequency converter, maintaining the same and the same start/stop settings (applied by [Hand On/Off]) as before the frequency converter was powered down. |
| [1] | Forced stop, ref=old | Restarts the frequency converter with a saved local reference, after mains voltage reappears and after pressing [Hand On]. |
| [2] | Forced stop, ref=0 | Resets the local reference to 0 upon restarting the frequency converter. |

| 0-06 GridType | | |
|---------------|-----------|--|
| Option: | Function: | |
| | | Select the grid type of the supply voltage/frequency. NOTE Not all choices are supported in all power sizes. IT grid is al supply mains, where the neutral point of secondary side |

| 0-06 GridType | | |
|---------------|-----------------------|---|
| Option: | Function: | |
| | | of the transformer is not connected to ground.. Delta is a supply mains where the secondary part of the transformer is delta connected and one phase is connected to ground. |
| [10] | 380-440V/50Hz/IT-grid | |
| [11] | 380-440V/50Hz/Delta | |
| [12] | 380-440V/50Hz | |
| [20] | 440-480V/50Hz/IT-grid | |
| [21] | 440-480V/50Hz/Delta | |
| [22] | 440-480V/50Hz | |
| [110] | 380-440V/60Hz/IT-grid | |
| [111] | 380-440V/60Hz/Delta | |
| [112] | 380-440V/60Hz | |
| [120] | 440-480V/60Hz/IT-grid | |
| [121] | 440-480V/60Hz/Delta | |
| [122] | 440-480V/60Hz | |

| 0-07 Auto DC Braking | | |
|----------------------|-----------|--|
| Option: | Function: | |
| | | Protective function against overvoltage at coast. WARNING Can cause PWM when coasted. |
| [0] | Off | Function is not active. |
| [1] | On | Function is active. |

3.1.2 0-1* Set-up Operations

Define and control the individual parameter set-ups. The frequency converter has two parameter set-ups that can be programmed independently of each other. This makes the frequency converter very flexible and able to solve advanced control functionality problems, often saving the cost of external control equipment. For example these can be used to program the frequency converter to operate according to one control scheme in one set-up (e.g. motor 1 for horizontal movement) and another control scheme in another set-up (e.g. motor 2 for vertical movement). Alternatively they can be used by an OEM machine builder to identically program all their factory fitted frequency converters for different machine types within a range to have the same parameters and then during production/commissioning simply select a specific set-up depending on which machine the frequency converter is installed on.

The active set-up (i.e. the set-up in which the frequency converter is currently operating) can be selected in *0-10 Active Set-up* and is displayed in the LCP. Using Multi set-up it is possible to switch between set-ups with the frequency converter running or stopped, via digital input or serial communication commands. If it is necessary to change set-ups while running, ensure *0-12 This Set-up Linked to* is programmed as required. Using *0-11 Edit Set-up* it is possible to edit parameters within any of the set-ups while continuing the frequency converter operation in its active set-up which can be a different set-up to that being edited. Using *0-51 Set-up Copy* it is possible to copy parameter settings between the set-ups to enable quicker commissioning if similar parameter settings are required in different set-ups.

| 0-10 Active Set-up | | |
|--------------------|--------------|---|
| Option: | Function: | |
| | | Select the set-up in which the frequency converter is to operate. Use <i>0-51 Set-up Copy</i> to copy a set-up to one or all set-ups. To avoid conflicting settings of the same parameter within two different set-ups, link the set-ups together using <i>0-12 Link Setups</i> . Stop the frequency converter before switching between set-ups where the parameters marked <i>Not changeable during operation</i> have different values. Parameters which are <i>Not changeable during operation</i> are marked FALSE in the parameter lists in <i>4 Parameter Lists</i> . |
| [1] | Set-up 1 | Set-up 1 is active. |
| [2] | Set-up 2 | Set-up 2 is active. |
| [9] | Multi Set-up | Is used for remote selection of set-ups using digital inputs and the serial communication port., This set-up uses the settings from <i>0-12 Link Setups</i> . |

| 0-11 Programming Set-up | | |
|-------------------------|---------------|--|
| Option: | Function: | |
| | | Select the set-up to be edited (i.e. programmed) during operation; either the active set-up or the inactive set-up. The set-up number being edited is displayed flashing in the LCP. |
| [1] | Set-up 1 | [1] Set-up 1 to [2] Set-up 2 can be edited freely during operation, independently of the active set-up. |
| [2] | Set-up 2 | |
| [9] | Active Set-up | (i.e. the set-up in which the frequency converter is operating) can also be edited during operation. |

| 0-12 Link Setups | | |
|------------------|------------|---|
| Option: | Function: | |
| | | The link ensures synchronising of the <i>Not changeable during operation</i> parameter values enabling shift from one set-up to another during operation. If the set-ups are not linked, a change between them is not possible while the motor is running. Thus the set-up change does not occur until the motor is coasted. |
| [0] | Not linked | Leaves parameters unchanged in both set-ups and cannot be changed while the motor runs. |
| [20] | Linked | Copies <i>Not changeable during operation</i> parameters from one set-up to the other, so they are identical in both set-ups. |

| 0-16 Application Selection | | |
|----------------------------|---------------------------|--|
| Option: | Function: | |
| [0] | None | |
| [1] | Simple Process Close Loop | |
| [2] | Local/Remote | |
| [3] | Speed Open Loop | |
| [4] | Simple Speed Close Loop | |
| [5] | Multi Speed | |

3.1.3 0-3* LCP Custom Readout

It is possible to customise the display elements for various purposes: *Custom Readout. Value proportional to speed (Linear, squared or cubed depending on unit selected in *0-30 Custom Readout Unit*) *Display Text. Text string stored in a parameter.

Custom Readout

The calculated value to be displayed is based on settings in *0-30 Custom Readout Unit*, *0-31 Custom Readout Min Value* (linear only), *0-32 Custom Readout Max Value*, *4-14 Motor Speed High Limit [Hz]* and actual speed.

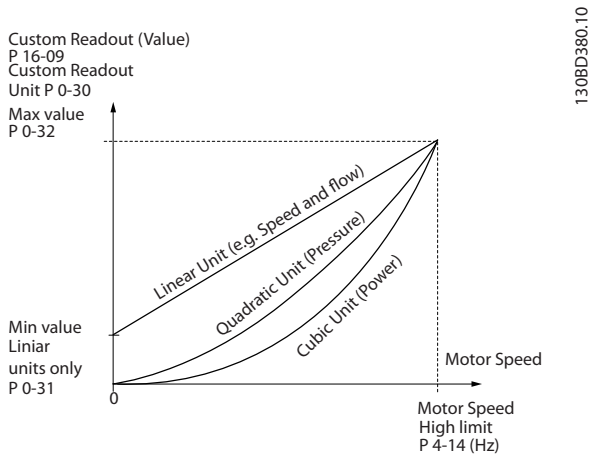

Illustration 3.1 Custom Readout

The relation will depend on the type of unit selected in 0-30 Custom Readout Unit:

| Unit Type | Speed Relation |
|---------------|----------------|
| Dimensionless | Linear |
| Speed | |
| Flow, volume | |
| Flow, mass | |
| Velocity | |
| Length | |
| Temperature | |
| Pressure | Quadratic |
| Power | Cubic |

Table 3.1 Relation between Unit Type and Speed

| 0-30 Custom Readout Unit | | |
|--------------------------|--|--|
| Option: | Function: | |
| | Program a value to be shown in the LCP. The value has a linear, squared or cubed relation to speed. This relation depends on the unit selected, see Table 3.1. The actual calculated valued can be read in 16-09 Custom Readout. | |
| [0] | None | |
| [1] | % | |
| [5] | PPM | |
| [10] | 1/min | |
| [11] | RPM | |
| [12] | Pulse/s | |
| [20] | l/s | |
| [21] | l/min | |
| [22] | l/h | |
| [23] | m ³ /s | |
| [24] | m ³ /min | |
| [25] | m ³ /h | |
| [30] | kg/s | |
| [31] | kg/min | |

| 0-30 Custom Readout Unit | | |
|--------------------------|--------------------|--|
| Option: | Function: | |
| [32] | kg/h | |
| [33] | t/min | |
| [34] | t/h | |
| [40] | m/s | |
| [41] | m/min | |
| [45] | m | |
| [60] | °C | |
| [70] | mbar | |
| [71] | bar | |
| [72] | Pa | |
| [73] | kPa | |
| [74] | m WG | |
| [80] | kW | |
| [120] | GPM | |
| [121] | gal/s | |
| [122] | gal/min | |
| [123] | gal/h | |
| [124] | CFM | |
| [127] | ft ³ /h | |
| [140] | ft/s | |
| [141] | ft/min | |
| [160] | °F | |
| [170] | psi | |
| [171] | lb/in2 | |
| [172] | in WG | |
| [173] | ft WG | |
| [180] | HP | |

| 0-31 Custom Readout Min Value | | |
|-------------------------------|------------------------------------|---|
| Range: | Function: | |
| 0 CustomReadoutUnit* | [0 - 999999.99 CustomReadoutUnit] | This parameter allows the choice of the min. value of the custom readout (occurs at zero speed). It is only possible to select a value different to 0 when selecting a linear unit in 0-30 Custom Readout Unit. For Quadratic and Cubic units the minimum value is 0. |

| 0-32 Custom Readout Max Value | | |
|-------------------------------|--------------------------------------|--|
| Range: | Function: | |
| 100 CustomReadoutUnit* | [0.0 - 999999.99 CustomReadoutUnit] | This parameter set the max. value to be shown when the motor speed has reached the value set for 4-14 Motor Speed High Limit [Hz]. |

3.1.4 0-4* LCP Keypad

Enable, disable and password protect individual keys on the LCP.

| 0-40 [Hand on] Key on LCP | | |
|---------------------------|-----------|---|
| Option: | Function: | |
| [0] | Disabled | Avoid accidental start of the frequency converter in Hand mode. |
| [1] | Enabled | [Hand On] is enabled. |

| 0-42 [Auto on] Key on LCP | | |
|---------------------------|-----------|---|
| Option: | Function: | |
| [0] | Disabled | Avoid accidental start of the frequency converter from LCP. |
| [1] | Enabled | [Hand On] is enabled. |

| 0-44 [Off/Reset] Key on LCP | | |
|-----------------------------|-------------------|--|
| Option: | Function: | |
| [0] | Disabled | |
| [1] | Enabled | |
| [7] | Enable Reset Only | |

3.1.5 0-5* Copy/Save

Copy parameter settings between set-ups and to/from the LCP.

| 0-50 LCP Copy | | |
|---------------|----------------------|---|
| Option: | Function: | |
| [0] | No copy | No function |
| [1] | All to LCP | Copies all parameters in all set-up from the frequency converter memory to the LCP memory. For service purposes it is recommended to copy all parameters to the LCP after commissioning. |
| [2] | All from LCP | Copies all parameters in all set-ups from the LCP memory to the frequency converter memory. |
| [3] | Size indep. from LCP | Copies only the parameters that are independent of the motor size. The latter selection can be used to programme several frequency converters with the same function without disturbing motor data already set. |

| 0-51 Set-up Copy | | |
|------------------|-------------------|---------------------------------|
| Option: | Function: | |
| [0] | No copy | No function |
| [1] | Copy from setup 1 | Copy from set-up 1 to set-up 2. |
| [2] | Copy from setup 2 | Copy from set-up 2 to set-up 1. |

| 0-51 Set-up Copy | | |
|------------------|-------------------------|---|
| Option: | Function: | |
| [9] | Copy from Factory setup | Copy factory setting to programming set-up (chosen in 0-11 Programming Set-up). |

3.1.6 0-6* Password

| 0-60 Main Menu Password | | |
|-------------------------|------------|--|
| Range: | Function: | |
| 0 * | [0 - 999] | Define the password for access to the Main Menu via the [Main Menu] key. Setting values to 0 disables the password function. |

3.2 Parameters: 1-** Load and Motor

3.2.1 1-0* General Settings

| 1-00 Configuration Mode | | |
|-------------------------|-----------------------|---|
| Option: | Function: | |
| | | Select the application control principle to be used when a Remote Reference (i.e. via analog input or fieldbus) is active. |
| [0] | Open Loop | Enables speed control (without feedback signal from motor) with automatic slip compensation for almost constant speed at varying loads. Compensations are active, but can be disabled in parameter group 1-0* Load and Motor. The speed control parameters are set in parameter group 7-0* Speed PID Control. |
| [1] | Speed closed loop | Enables Speed closed loop control with feedback. For increased speed accuracy, provide a feedback signal and set the speed PID control. The speed control parameters are set in parameter group 7-0* Speed PID Control. |
| [3] | Process Closed Loop | Enables the use of process control in the frequency converter. The process control parameters are set in parameter groups 7-2* Process Ctrl. Feedback and 7-3* Process PID Ctrl. |
| [4] | Torque open loop | |
| [7] | Extended PID Speed OL | |

| 1-01 Motor Control Principle | | |
|------------------------------|-----------|--|
| Option: | Function: | |
| [0] | U/f | Is used for parallel connected motors and/or special motor applications. The U/f settings are set in 1-55 U/f Characteristic - U and 1-56 U/f Characteristic - F. NOTE When running U/f control slip and load compensations are not included. |
| [1] | VVC+ | Normal running mode, including slip- and load compensations. NOTE If 1-10 = [1] PM, only VVC+ option is available. |

| 1-03 Torque Characteristics | | |
|-----------------------------|-----------------------|--|
| Option: | Function: | |
| | | Select the torque characteristic required. VT and AEO are both energy saving operations. |
| [0] | Constant torque | |
| [1] | Variable Torque | |
| [2] | Auto Energy Optim. CT | |
| [3] | Auto Energy Optim. VT | |

| 1-06 Clockwise Direction | | |
|--------------------------|-----------|--|
| Option: | Function: | |
| | | NOTE This parameter cannot be changed while the motor is running. This parameter defines the term "Clockwise" corresponding to the LCP direction arrow. Used for easy change of direction of shaft rotation without swapping motor wires. |
| [0] | Normal | Motor shaft will turn in clockwise direction when frequency converter is connected U -> U; V -> V, and W -> W to motor. |
| [1] | Inverse | Motor shaft will turn in counter clockwise direction when frequency converter is connected U -> U; V -> V, and W -> W to motor. |

| 1-10 Motor Construction | | |
|-------------------------------------|---------------------|---|
| Select the motor construction type. | | |
| Option: | Function: | |
| [0] | Asynchron | For asynchronous motors. |
| [1] | PM, non salient SPM | For permanent magnet (PM) motors. Note that PM motors are divided into two groups, with either surface mounted (non salient) or interior (salient) magnets. NOTE Only available up to 22 kW motor power. |

NOTE
Motor construction can either be asynchronous or permanent magnet (PM) motor.

3.2.2 1-2* Motor Data

This parameter group comprises input data from the nameplate on the connected motor.

3

NOTE

Changing the value of these parameters affects the setting of other parameters.

3.2.3 1-20 Motor Power

| 1-20 Motor Power | | Function: |
|------------------|-------------------|-----------|
| Option: | | |
| [2] | 0.12 kW - 0.16 hp | |
| [3] | 0.18 kW - 0.25 hp | |
| [4] | 0.25 kW - 0.33 hp | |
| [5] | 0.37 kW - 0.5 hp | |
| [6] | 0.55 kW - 0.75 hp | |
| [7] | 0.75 kW - 1 hp | |
| [8] | 1.1 kW - 1.5 hp | |
| [9] | 1.5 kW - 2 hp | |
| [10] | 2.2 kW - 3 hp | |
| [11] | 3 kW - 4 hp | |
| [12] | 3.7 kW - 5 hp | |
| [13] | 4 kW - 5.4 hp | |
| [14] | 5.5 kW - 7.5 hp | |
| [15] | 7.5 kW - 10 hp | |
| [16] | 11 kW - 15 hp | |
| [17] | 15 kW - 20 hp | |
| [18] | 18.5 kW - 25 hp | |
| [19] | 22 kW - 30 hp | |
| [20] | 30 kW - 40 hp | |
| [21] | 37 kW - 50 hp | |
| [22] | 45 kW - 60 hp | |
| [23] | 55 kW - 75 hp | |
| [24] | 75 kW - 100 hp | |
| [25] | 90 kW - 120 hp | |
| [26] | 110 kW - 150 hp | |

| 1-22 Motor Voltage | | Function: |
|--------------------|---------------------|---|
| Range: | | |
| Size related* | [50.0 - 1000.0 V] | Enter the nominal motor voltage according to the motor nameplate data. The default value corresponds to the nominal rated output of the unit. |

| 1-23 Motor Frequency | | Function: |
|----------------------|--|---|
| Range: | | |
| | | NOTE This parameter cannot be changed while the motor is running. |

| 1-23 Motor Frequency | | Function: |
|----------------------|-----------------|---|
| Range: | | |
| Size related* | [20 - 500 Hz] | Select the motor frequency value from the motor nameplate. For 87 Hz operation with 230/440 V motors, set the nameplate data for 230 V/50 Hz. Adapt 4-14 <i>Motor Speed High Limit [Hz]</i> and 3-03 <i>Maximum Reference</i> to the 87 Hz application. |

| 1-24 Motor Current | | Function: |
|--------------------|-------------------|--|
| Range: | | |
| Size related* | [0.01 - 26.0 A] | Enter the nominal motor current value from the motor nameplate data. This data is used for calculating motor torque, motor thermal protection etc. |

| 1-25 Motor Nominal Speed | | Function: |
|--------------------------|---------------------|---|
| Range: | | |
| Size related* | [100 - 60000 RPM] | Enter the nominal motor speed value from the motor nameplate data. This data is used for calculating automatic motor compensations. |

| 1-29 Automatic Motor Adaption (AMA) | | Function: |
|-------------------------------------|---------------------|---|
| Option: | | |
| | | NOTE This parameter cannot be adjusted while the motor is running. The AMA function optimizes dynamic motor performance by automatically optimizing the advanced motor 1-30 <i>Stator Resistance (Rs)</i> to 1-35 <i>Main Reactance (Xh)</i> while the motor is stationary. |
| [0] | Off | No function |
| [1] | Enable Complete AMA | Performs AMA of the stator resistance R_s , the stator leakage reactance X_l and the main reactance X_h . NOTE Terminal 27 Digital Input (5-12 Terminal 27 Digital Input) has coast inverse as default setting. This means that AMA can not be performed if there is no 24 V to terminal 27, so please connect terminal 12 to terminal 27. |
| [2] | Enable Reduced AMA | Performs a reduced AMA of the stator resistance R_s in the system only. Select this option if an LC filter is used between the frequency converter and the motor. |

NOTE

When *1-10 Motor Construction* is set to [1] *PM, non-salient SPM*, the only option available is [2] *Enable Reduced AMA*.

Activate the AMA function by pressing [Hand On] after selecting [1] or [2]. After a normal sequence, the display will read: "Press [OK] to finish AMA". After pressing [OK], the frequency converter is ready for operation.

NOTE

- For the best adaptation of the frequency converter, run AMA on a cold motor
- AMA cannot be performed while the motor is running
- AMA can not be performed on a motor with a bigger power rating than the frequency converter, e.g. when a 5.5 kW motor is connected to a 4 kW frequency converter.

NOTE

Avoid generating external torque during AMA.

NOTE

If one of the settings in parameter group *1-2* Motor Data* is changed, the advanced motor parameters, *1-30 Stator Resistance (Rs)* to *1-39 Motor Poles*, will return to default setting.

NOTE

Full AMA should be run without filter only while reduced AMA should be run with filter.

| 1-30 Stator Resistance (Rs) | | |
|----------------------------------|---|--|
| Range: | Function: | |
| Size related* [0.0 - 99.99 Ohm] | Set the stator resistance value. Enter the value from a motor data sheet or perform an AMA on a cold motor. This parameter cannot be adjusted while the motor is running. | |

| 1-33 Stator Leakage Reactance (X1) | | |
|------------------------------------|--|--|
| Range: | Function: | |
| Size related* [0.0 - 999.9 Ohm] | Set stator leakage reactance of motor. | |

| 1-35 Main Reactance (Xh) | | |
|----------------------------------|---|--|
| Range: | Function: | |
| Size related* [0.0 - 999.9 Ohm] | Set the main reactance of the motor using one of these methods: | |

| 1-35 Main Reactance (Xh) | | |
|--------------------------|---|--|
| Range: | Function: | |
| | <ol style="list-style-type: none"> 1. Run an AMA on a cold motor. The frequency converter will measure the value from the motor. 2. Enter the X_h value manually. Obtain the value from the motor supplier. 3. Use the X_h default setting. The frequency converter establishes the setting on the basis of the motor name plate data. | |

| 1-39 Motor Poles | | | |
|------------------|--|-------------------------|-------------------------|
| Range: | Function: | | |
| 4 * [2 - 100] | Enter the number of motor poles. | | |
| | Poles | ~n _n @ 50 Hz | ~n _n @ 60 Hz |
| | 2 | 2700-3000 | 3250-3600 |
| | 4 | 1350-1500 | 1625-1800 |
| | 6 | 700-1000 | 840-1200 |
| | The table shows the number of poles for normal speed ranges of various motor types. Define motors designed for other frequencies separately. The motor pole value is always an even number, because it refers to the total number of poles, not pairs of poles. This parameter cannot be adjusted while the motor is running. | | |

| 1-42 Motor Cable Length | | |
|-------------------------|--------------|--|
| Range: | Function: | |
| 50 m* | [0 - 100 m] | |

| 1-43 Motor Cable Length Feet | | |
|------------------------------|---------------|--|
| Range: | Function: | |
| 164 ft* | [0 - 328 ft] | |

| 1-50 Motor Magnetisation at Zero Speed | | |
|--|--|--|
| Range: | Function: | |
| 100 %* [0 - 300.0 %] | Use this parameter along with <i>1-52 Min Speed Normal Magnetising [Hz]</i> to obtain a different thermal load on the motor when running at low speed. Enter a value which is a percentage of the rated magnetising current. If the setting is too low, the torque on the motor shaft may be reduced. | |

1-50 Motor Magnetisation at Zero Speed

Range: **Function:**

Illustration 3.2

1-52 Min Speed Normal Magnetising [Hz]

Range: **Function:**

| | | |
|-------|------------------|---|
| 1 Hz* | [0.1 - 10.0 Hz] | Set the required frequency for normal magnetising current. Use this parameter along with 1-50 Motor Magnetisation at Zero Speed, also see Illustration 3.2. |
|-------|------------------|---|

1-55 U/f Characteristic - U

Range: **Function:**

| | | |
|---------------|--------------|--|
| Size related* | [0 - 500 V] | Enter voltage at each frequency point to manually form a U/f characteristic matching motor. Frequency points are defined in 1-56 U/f Characteristic - F. |
|---------------|--------------|--|

1-56 U/f Characteristic - F

Range: **Function:**

| | | |
|---------------|-----------------|--|
| Size related* | [0 - 400.0 Hz] | Enter frequency points to manually form a U/f characteristic matching motor. Voltage at each point is defined in 1-55 U/f Characteristic - U. Make a U/f characteristic based on 6 definable voltagesd and frequencies, see Illustration 3.3. |
|---------------|-----------------|--|

Illustration 3.3 Example of U/f Characteristic

1-60 Low Speed Load Compensation

Range: **Function:**

| | | |
|--------|--------------|--|
| 100 %* | [0 - 300 %] | Enter the low speed voltage compensation value in percent. This parameter is used for optimising the low speed load performance. This parameter is only active if 1-10 Motor Construction = [0] Asynchron. |
|--------|--------------|--|

1-61 High Speed Load Compensation

Range: **Function:**

| | | |
|--------|--------------|--|
| 100 %* | [0 - 300 %] | Enter the high speed load voltage compensation value in percent. This parameter is used for optimising the high speed load performance. This parameter is only active if 1-10 Motor Construction = [0] Asynchron |
|--------|--------------|--|

1-62 Slip Compensation

Range: **Function:**

| | | |
|---------------|-------------------|---|
| Size related* | [-400 - 399.0 %] | Enter the % value for slip compensation to compensate for tolerance in the value of n _{M,N} . Slip compensation is calculated automatically, i.e. on the basis of the rated motor speed n _{M,N} . |
|---------------|-------------------|---|

1-63 Slip Compensation Time Constant

Range: **Function:**

| | | |
|--------|------------------|---|
| 0.1 s* | [0.05 - 5.00 s] | Enter the slip compensation reaction speed. A high value results in slow reaction, and a low value results in quick reaction. If low-frequency resonance problems arise, use a longer time setting. |
|--------|------------------|---|

1-64 Resonance Dampening

Range: **Function:**

| | | |
|--------|--------------|--|
| 100 %* | [0 - 500 %] | Enter the resonance dampening value. Set 1-64 Resonance Dampening and 1-65 Resonance Dampening Time Constant to help eliminate high-frequency resonance problems. To reduce resonance oscillation, increase the value of 1-64 Resonance Dampening. |
|--------|--------------|--|

1-65 Resonance Dampening Time Constant

Range: **Function:**

| | | |
|----------|-------------------|--|
| 0.005 s* | [0.001 - 0.05 s] | Set 1-64 Resonance Dampening and 1-65 Resonance Dampening Time Constant to help eliminate high-frequency resonance problems. Enter the time constant that provides the best dampening. |
|----------|-------------------|--|

1-71 Start Delay

Range: **Function:**

| | | |
|------|-------------|---|
| 0 s* | [0 - 10 s] | This parameter enables a delay of the starting time. The frequency converter begins with the start function selected in 1-72 Start Function. Set the start delay time until acceleration is to begin. |
|------|-------------|---|

| 1-72 Start Function | | |
|---------------------|----------------------|---|
| Option: | Function: | |
| | | Select the start function during start delay. This parameter is linked to <i>1-71 Start Delay</i> . |
| [0] | DC Hold/delay time | |
| [2] | Coast/delay time | |
| [3] | Start speed cw | |
| [4] | Horizontal operation | |
| [5] | VVC+ clockwise | The start speed is calculated automatically. This function uses the start speed in the start delay time only. |

| 1-73 Flying Start | | |
|-------------------|------------------------|---|
| Option: | Function: | |
| | | <p>NOTE This parameter cannot be changed while the motor is running.</p> <p>NOTE To obtain the best flying start performance, the advanced motor data, <i>1-30 Stator Resistance (Rs)</i> to <i>1-35 Main Reactance (Xh)</i>, must be correct.</p> <p>Catches a motor which is spinning freely due to a mains drop-out.</p> |
| [0] | Disabled | No function |
| [1] | Enabled | Enables the frequency converter to catch and control a spinning motor. When <i>1-73 Flying Start</i> is enabled, <i>1-71 Start Delay</i> and <i>1-72 Start Function</i> have no function. |
| [2] | Enabled Always | |
| [3] | Enabled Ref. Dir. | |
| [4] | Enab. Always Ref. Dir. | |

| 1-75 Start Speed [Hz] | | |
|-----------------------|-------------|--|
| Range: | Function: | |
| Size related* | [0 - 10 Hz] | This parameter can be used for hoist applications (cone rotor). Set a motor start speed. After the start signal, the output speed leaps to set value. Set the start function in <i>1-72 Start Function</i> to [3] <i>Start speed cw</i> , [4] <i>Horizontal operation</i> or [5] <i>VVC^{plus} clockwise</i> , and set a start delay time in <i>1-71 Start Delay</i> . |

| 1-76 Start Current | | |
|--------------------|---------------|---|
| Range: | Function: | |
| Size related* | [0 - 10000 A] | Some motors, e.g. cone rotor motors, need extra current/starting speed to disengage the rotor. To obtain this boost, set the required current in this parameter. Set <i>1-72 Start Function</i> to [3] <i>Start speed cw</i> or [4] <i>Horizontal operation</i> , and set a start delay time in <i>1-71 Start Delay</i> . |

| 1-78 Compressor Start Max Speed [Hz] | | |
|--------------------------------------|--------------|--|
| Range: | Function: | |
| 0 Hz* | [0 - 650 Hz] | This parameter enables high starting torque. This function ignores current limit and torque limit during start of the motor. The time, from the start signal is given until the speed exceeds the speed set in this parameter, becomes a "start zone" where the current limit and motoric torque limit are set to what is maximum possible for the frequency converter/motor combination. The time without protection from the current limit and torque limit must not exceed the value set in <i>1-79 Compressor Start Max Time to Trip</i> . Otherwise, the frequency converter trips with <i>Alarm 18, Start Failed</i> . |

| 1-79 Compressor Start Max Time to Trip | | |
|--|------------|---|
| Range: | Function: | |
| 5 s* | [0 - 10 s] | The time, from the start signal ia given until the speed exceeds the speed set in <i>1-78 Compressor Start Max Speed [Hz]</i> must not exceed the time set in this parameter. Otherwise, the frequency converter trips with <i>Alarm 18, Start Failed</i> . Any time set in <i>1-71 Start Delay</i> for use of a start function must be executed within the time limit. |

| 1-80 Function at Stop | | |
|-----------------------|-----------|--|
| Option: | Function: | |
| | | Select the frequency converter function after a stop command or after the speed is ramped down to the settings in <i>1-82 Min Speed for Function at Stop [Hz]</i> . Available selections depend on <i>1-10 Motor Construction</i> . |
| | | [0] Asynchron |
| | | [0] Coast |
| | | [1] DC-hold |
| | | [2] Motor check, warning |
| | | [6] Motor check, alarm |
| | | PM non salient |
| | | [0] Coast |
| [0] | Coast | Leaves motor in free mode. |

| 1-80 Function at Stop | | |
|-----------------------------|--|--|
| Option: | Function: | |
| [1] DC hold / Motor Preheat | Energises motor with a DC holding current (see 2-00 DC Hold/Motor Preheat Current. | |
| [3] Pre-magnetizing | <p>Builds up a magnetic field while the motor is stopped. This allows the motor to produce torque quickly at commands (asynchronous motors only). This pre-magnetising function does not help the very first start command. Two different solutions are available to pre-magnetise the machine for the first start command.</p> <ol style="list-style-type: none"> 1. Start the frequency converter with a 0 RPM reference and wait 2 to 4 rotor time constants (see below) before increasing the speed reference. 2. Set 1-71 Start Delay to the desired pre-mag time (2 to 4 rotor time constants). 3. Set 1-72 Start Function to either [0] DC-hold or [1] DC-brake. 4. Set the DC-hold or DC-brake current magnitude (2-00 DC Hold/Motor Preheat Current or 2-01 DC Brake Current) to be equal to $I_{pre-mag} = U_{nom}/(1.73 \times X_h)$ <p>Sample rotor time constants = $(X_h + X_2)/(6.3 \times Freq_{nom} \times R_r)$</p> <p>1 kW = 0.2 s 10 kW = 0.5 s 100 kW = 1.7 s</p> | |

| 1-82 Min Speed for Function at Stop [Hz] | | |
|--|--|--|
| Range: | Function: | |
| 0 Hz* [0 - 20 Hz] | Set the output frequency at which to activate 1-80 Function at Stop. | |

| 1-90 Motor Thermal Protection | | |
|-------------------------------|---|--|
| Option: | Function: | |
| [0] No protection | Continuously overloaded motor, when no warning or trip of the frequency converter is required. | |
| [1] Thermistor warning | Activates a warning when the connected thermistor or KTY-sensor in the motor reacts in the event of motor over-temperature. | |
| [2] Thermistor trip | <p>Stops (trips) the frequency converter when the connected thermistor or KTY-sensor in the motor reacts in the event of motor over-temperature.</p> <p>The thermistor cut-out value must be > 3 kΩ.</p> | |

| 1-90 Motor Thermal Protection | | |
|-------------------------------|---|--|
| Option: | Function: | |
| | | Integrate a thermistor (PTC sensor) in the motor for winding protection. |
| [3] ETR warning 1 | Calculates the load when set-up 1 is active and activates a warning in the display when the motor is overloaded. Programme a warning signal via one of the digital outputs. | |
| [4] ETR trip 1 | Calculates the load when set-up 1 is active and stops (trips) the frequency converter when the motor is overloaded. Programme a warning signal via one of the digital outputs. The signal appears in the event of a warning and if the frequency converter trips (thermal warning). | |

| 1-93 Thermistor Source | | |
|------------------------|---|--|
| Option: | Function: | |
| | <p>NOTE This parameter cannot be changed while the motor is running.</p> <p>NOTE Digital input should be set to [0] PNP - Active at 24 V in 5-00 Digital I/O Mode.</p> <p>Select the input to which the thermistor (PTC sensor) should be connected. An analog input option [1] or [2] cannot be selected if the analog input is already in use as a reference source (selected in 3-15 Reference 1 Source, 3-16 Reference 2 Source or 3-17 Reference 3 Source.</p> | |
| [0] | None | |
| [1] | Analog Input 53 | |
| [2] | Analog Input 54 | |
| [3] | Digital input 18 | |
| [4] | Digital input 19 | |
| [5] | Digital input 32 | |
| [6] | Digital input 33 | |
| [7] | Digital input 31 | |

3.3 Parameters: 2-** Brakes

| 2-00 DC Hold/Motor Preheat Current | | |
|--|-------------|--|
| Range: | | Function: |
| 50 %* | [0 - 160 %] | Set holding current as a percentage of the rated motor current $I_{M,N}$ 1-24 <i>Motor Current</i> . This parameter holds the motor function (holding torque) or pre-heats the motor. This parameter is active if [0] <i>DC hold</i> is selected in 1-72 <i>Start Function</i> , or if [1] <i>DC hold/pre-heat</i> is selected in 1-80 <i>Function at Stop</i> . |
| <p>NOTE The maximum value depends on the rated motor current. Avoid 100% current for too long. It may damage the motor.</p> | | |

| 2-01 DC Brake Current | | |
|-----------------------|-------------|--|
| Range: | | Function: |
| 50 %* | [0 - 150 %] | Set current as % of rated motor current, 1-24 <i>Motor Current</i> . DC brake current is applied on stop command, when speed is below the limit set in 2-04 <i>DC Brake Cut In Speed</i> ; when the DC Brake Inverse function is active; or via the serial port. See 2-02 <i>DC Braking Time</i> for duration. |

NOTE

The maximum value depends on the rated motor current. Avoid 100% current for too long. It may damage the motor.

| 2-02 DC Braking Time | | |
|----------------------|------------|--|
| Range: | | Function: |
| 10 s* | [0 - 60 s] | Set the duration of the DC braking current set in 2-01 <i>DC Brake Current</i> , once activated. |

| 2-04 DC Brake Cut In Speed | | |
|----------------------------|--------------|--|
| Range: | | Function: |
| 0 Hz* | [0 - 400 Hz] | This parameter is for setting the DC brake cut in speed at which the DC braking current 2-01 <i>DC Brake Current</i> is to be active, in connection with a stop command. |

NOTE

2-01, 2-02 and 2-04 will not have effect when 1-10 *Motor Construction* = [1] *PM, non salient SPM*.

3.3.1 2-1* Brake Energy Funct.

Parameter group for selecting dynamic braking parameters. Only valid for frequency converters with brake chopper.

| 2-10 Brake Function | | |
|---------------------|----------------|--|
| Option: | | Function: |
| [0] | Off | No brake resistor is installed. |
| [1] | Resistor brake | A brake resistor is incorporated in the system for dissipation of surplus brake energy as heat. Connecting a brake resistor allows a higher DC link voltage during braking (generating operation). The brake resistor function is only active in frequency converters with an integral dynamic brake. |
| [2] | AC brake | Improves braking without using a brake resistor. This parameter controls an over-magnetisation of the motor when running with a generative load. This function can improve the OVC-function. Increasing the electrical losses in the motor, allows the OVC-function to increase braking torque without exceeding the voltage limit. NOTE The AC brake is not as efficient as dynamic braking with resistor. AC brake is for VVC ^{plus} mode in both open and closed loop. |

| 2-11 Brake Resistor (ohm) | | |
|---------------------------|-----------------|---|
| Range: | | Function: |
| Size related* | [0 - 65535 Ohm] | Set the brake resistor value in Ω. This value is used for monitoring the power to the brake resistor. 2-11 <i>Brake Resistor (ohm)</i> is only active in frequency converters with an integral dynamic brake. Use this parameter for values without decimals. |

| 2-12 Brake Power Limit (kW) | | |
|-----------------------------|-------------------|--|
| Range: | | Function: |
| Size related* | [0.001 - 2000 kW] | 2-12 <i>Brake Power Limit (kW)</i> is the expected average power dissipated in the brake resistor over a period of 120 s. It is used as the monitoring limit for 16-33 <i>Brake Energy /2 min</i> and thereby specifies when a warning/ alarm is to be given. To calculate 2-12 <i>Brake Power Limit (kW)</i> , the following formula can be used. $P_{br,avg}[W] = \frac{U_{br}^2[V] \times t_{br}[s]}{R_{br}[\Omega] \times T_{br}[s]}$ $P_{br,avg}$ is the average power dissipated in the brake resistor, R_{br} is the resistance of the |

| 2-12 Brake Power Limit (kW) | | |
|-----------------------------|-----------|---|
| Range: | Function: | |
| | | brake resistor. t_{br} is the active breaking time within the 120 s period, T_{br} . U_{br} is the DC voltage where the brake resistor is active. This depends on the unit as follows: T4 units: 778 V NOTE If R_{br} is not known or if T_{br} is different from 120 s, the practical approach is to run the brake application, readout 16-33 Brake Energy /2 min and then enter this + 20% in 2-12 Brake Power Limit (kW). |

| 2-16 AC Brake, Max current | | |
|----------------------------|-------------|---|
| Range: | Function: | |
| 100 %* | [0 - 160 %] | Enter the maximum permissible current when using AC brake to avoid overheating of motor windings. NOTE 2-16 AC Brake, Max current will not have effect when 1-10 Motor Construction is set to [1] PM, non salient SPM. |

| 2-17 Over-voltage Control | | |
|---------------------------|-----------------------|---|
| Option: | Function: | |
| | | Over-voltage control (OVC) reduced the risk of the frequency converter tripping due to an over-voltage on the DC link caused by generative power from the load. |
| [0] | Disabled | No OVC required. |
| [1] | Enabled (not at stop) | Activates OVC except when using a stop signal to stop the frequency converter. |
| [2] | Enabled | Activates OVC NOTE OVC must NOT be enabled in hoisting applications. |

| 2-19 Over-voltage Gain | | |
|------------------------|-------------|---------------------------|
| Range: | Function: | |
| 100 %* | [0 - 200 %] | Select over-voltage gain. |

3.3.2 2-2* Mechanical Brake

| 2-20 Release Brake Current | | |
|----------------------------|-------------|--|
| Range: | Function: | |
| 0 A* | [0 - 100 A] | Set the motor current for release of the mechanical brake, when a start condition is present. The default value is the maximum current the inverter can provide for the particular power size. The upper limit is specified in 16-37 Inv. Max. Current. NOTE When Mechanical brake control output is selected but no mechanical brake is connected, the function will not work by default setting due to too low motor current. |

| 2-22 Activate Brake Speed [Hz] | | |
|--------------------------------|--------------|--|
| Range: | Function: | |
| 0 Hz* | [0 - 400 Hz] | Set the motor frequency for activation of the mechanical brake when a stop condition is present. |

3.4 Parameters: 3-** Reference/Ramps

3.4.1 3-0* Reference Limits

Parameters for setting the reference unit, limits and ranges.

| 3-00 Reference Range | | |
|----------------------|-------------|---|
| Option: | Function: | |
| [0] | Min - Max | Select the range of the reference signal and the feedback signal. Signal values can be positive only, or positive and negative. |
| [1] | -Max - +Max | For both positive and negative values (both directions), relative to <i>4-10 Motor Speed Direction</i> . |

| 3-01 Reference/Feedback Unit | | |
|------------------------------|----------------------|--|
| Option: | Function: | |
| [0] | None | |
| [1] | % | |
| [2] | RPM | |
| [3] | Hz | |
| [4] | Nm | |
| [5] | PPM | |
| [10] | 1/min | |
| [12] | Pulse/s | |
| [20] | l/s | |
| [21] | l/min | |
| [22] | l/h | |
| [23] | m ³ /s | |
| [24] | m ³ /min | |
| [25] | m ³ /h | |
| [30] | kg/s | |
| [31] | kg/min | |
| [32] | kg/h | |
| [33] | t/min | |
| [34] | t/h | |
| [40] | m/s | |
| [41] | m/min | |
| [45] | m | |
| [60] | °C | |
| [70] | mbar | |
| [71] | bar | |
| [72] | Pa | |
| [73] | kPa | |
| [74] | m WG | |
| [80] | kW | |
| [120] | GPM | |
| [121] | gal/s | |
| [122] | gal/min | |
| [123] | gal/h | |
| [124] | CFM | |
| [125] | ft ³ /s | |
| [126] | ft ³ /min | |
| [127] | ft ³ /h | |
| [130] | lb/s | |

| 3-01 Reference/Feedback Unit | | |
|------------------------------|-----------|--|
| Option: | Function: | |
| [131] | lb/min | |
| [132] | lb/h | |
| [140] | ft/s | |
| [141] | ft/min | |
| [145] | ft | |
| [150] | lb ft | |
| [160] | °F | |
| [170] | psi | |
| [171] | lb/in2 | |
| [172] | in WG | |
| [173] | ft WG | |
| [180] | HP | |

| 3-02 Minimum Reference | | |
|---------------------------|------------------------------------|---|
| Range: | Function: | |
| 0 Reference-FeedbackUnit* | [0 - 4999 ReferenceFeed-backUnit] | <p>Enter the Minimum Reference. The Minimum Reference is the lowest value obtainable by summing all references. Minimum Reference is active only when <i>3-00 Reference Range</i> is set to <i>[0] Min.- Max</i>. The Minimum Reference unit matches:</p> <ul style="list-style-type: none"> The choice of configuration in <i>1-00 Configuration Mode Configuration Mode</i>: for <i>[1] Speed closed loop</i> The unit selected in <i>3-01 Reference/ Feedback Unit</i> |

| 3-03 Maximum Reference | | |
|------------------------|---|--|
| Range: | Function: | |
| Size related* | [-4999.0 - 4999 ReferenceFeed-backUnit] | <p>Enter the Maximum Reference. The Maximum Reference is the highest value obtainable by summing all references.</p> <p>The Maximum Reference unit matches:</p> <ul style="list-style-type: none"> The choice of configuration in <i>1-00 Configuration Mode</i>: for <i>[1] Speed closed loop</i> The unit selected in <i>3-00 Reference Range</i> |

| 3-04 Reference Function | | |
|-------------------------|-----------------|---|
| Option: | Function: | |
| [0] | Sum | Sums both external and preset reference sources. |
| [1] | External/Preset | Use either the preset or the external reference source. Shift between external and preset via a command or a digital input. |

3.4.2 3-1* References

Select the preset reference(s). Select Preset ref. bit 0/1/2 [16], [17] or [18] for the corresponding digital inputs in parameter group 5-1* Digital Inputs.

| 3-10 Preset Reference | | |
|-----------------------|----------------|---|
| Range: | Function: | |
| 0 %* | [-100 - 100 %] | Enter up to eight different preset references (0-7) in this parameter, using array programming. Select Preset Reference bit 0/1/2 [16], [17] or [18] for the corresponding digital inputs in parameter group 5.1* Digital Inputs. |

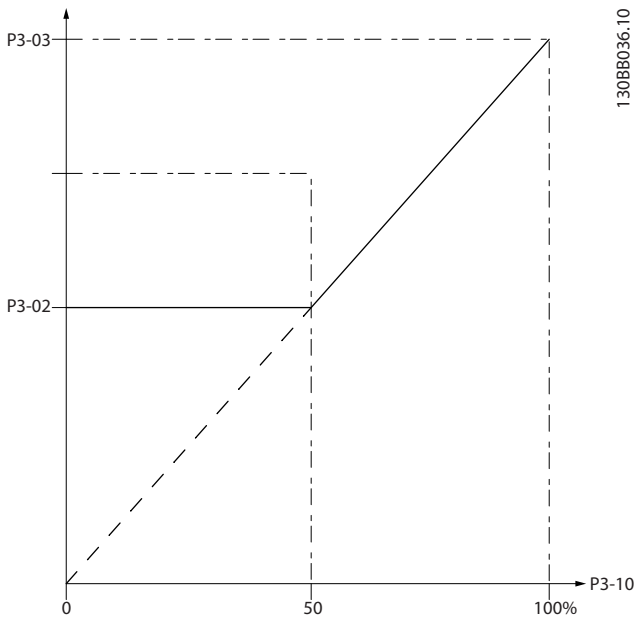

Illustration 3.4 Preset References

| 3-11 Jog Speed [Hz] | | |
|---------------------|----------------|---|
| Range: | Function: | |
| 5 Hz* | [0 - 400.0 Hz] | The jog speed is a fixed output speed which the frequency converter is running when the jog function is activated. See also 3-80 Jog Ramp Time. |

| 3-12 Catch up/slow Down Value | | |
|-------------------------------|-------------|---|
| Range: | Function: | |
| 0 %* | [0 - 100 %] | Enter a percentage (relative) value to be either added to or deducted from the actual reference for Catch up or Slow down respectively. If Catch up is selected via one of the digital inputs (5-10 Terminal 18 Digital Input to 5-15 Terminal 33 Digital Input), the percentage (relative) value is added to the total reference. If Slow down is selected via one of the digital inputs (5-10 Terminal 18 Digital Input to 5-15 Terminal 33 Digital Input), the percentage (relative) value is deducted from the total reference. |

| 3-14 Preset Relative Reference | | |
|--------------------------------|----------------|---|
| Range: | Function: | |
| 0 %* | [-100 - 100 %] | The actual reference, X, is increased or decreased with the percentage Y, set in 3-14 Preset Relative Reference. This results in the actual reference Z. Actual reference (X) is the sum of the inputs selected in 3-15 Reference 1 Source, 3-16 Reference 2 Source, 3-17 Reference 3 Source and 8-02 Control Source. |

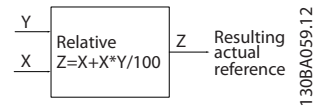

Illustration 3.5 Preset Relative Reference

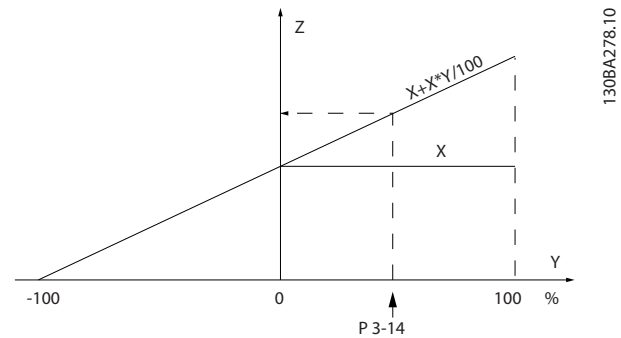

Illustration 3.6 Actual Reference

| 3-15 Reference 1 Source | | |
|-------------------------|-----------------|---|
| Option: | Function: | |
| [0] | No function | Select the reference input to be used for the first reference signal. 3-15 Reference 1 Source, 3-16 Reference 2 Source and 3-17 Reference 3 Source define up to three different reference signals. The sum of these reference signals defines the actual reference. |
| [1] | Analog Input 53 | |

| 3-15 Reference 1 Source | |
|-------------------------|---------------------|
| Option: | Function: |
| [2] | Analog Input 54 |
| [7] | Frequency input 29 |
| [8] | Frequency input 33 |
| [11] | Local bus reference |

| 3-16 Reference 2 Source | |
|-------------------------|---|
| Option: | Function: |
| | Select the reference input to be used for the first reference signal. 3-15 Reference 1 Source, 3-16 Reference 2 Source and 3-17 Reference 3 Source define up to three different reference signals. The sum of these reference signals defines the actual reference. |
| [0] | No function |
| [1] | Analog Input 53 |
| [2] | Analog Input 54 |
| [7] | Frequency input 29 |
| [8] | Frequency input 33 |
| [11] | Local bus reference |

| 3-17 Reference 3 Source | |
|-------------------------|---|
| Option: | Function: |
| | Select the reference input to be used for the first reference signal. 3-15 Reference 1 Source, 3-16 Reference 2 Source and 3-17 Reference 3 Source define up to three different reference signals. The sum of these reference signals defines the actual reference. |
| [0] | No function |
| [1] | Analog Input 53 |
| [2] | Analog Input 54 |
| [7] | Frequency input 29 |
| [8] | Frequency input 33 |
| [11] | Local bus reference |

| 3-18 Relative Scaling Reference Resource | |
|--|--|
| Option: | Function: |
| | NOTE This parameter cannot be adjusted while the motor is running. Select a variable value to be added to the fixed value (defined in 3-14 Preset Relative Reference). The sum of the fixed and variable values (labelled Y in Illustration 3.7) is multiplied with the actual reference (labelled X in Illustration 3.7). This product is then added to the actual reference (X+X*Y/100) to give the resultant actual reference. |

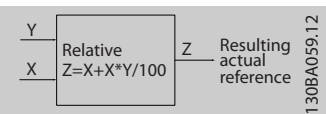
| 3-18 Relative Scaling Reference Resource | |
|--|---|
| Option: | Function: |
| |  <p>Illustration 3.7 Resultant Actual Reference</p> |
| [0] | No function |
| [1] | Analog Input 53 |
| [2] | Analog Input 54 |
| [7] | Frequency input 29 |
| [8] | Frequency input 33 |
| [11] | Local bus reference |

3

3.4.3 3-4* Ramp 1

Configure the ramp parameter, ramping times, for each of the two ramps (parameter group 3-4* Ramp 1 and parameter group 3-5* Ramp 2).

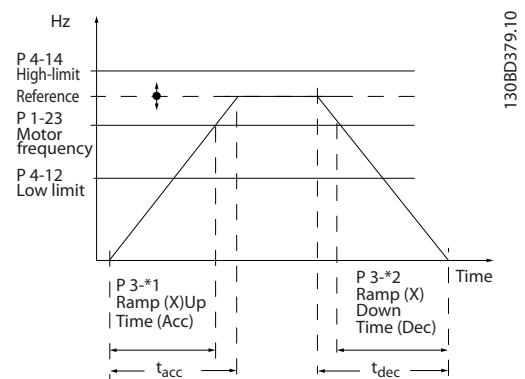

Illustration 3.8 Example of Ramp 1

| 3-40 Ramp 1 Type | |
|------------------|---|
| Option: | Function: |
| | Select the ramp type, depending on requirements for acceleration/deceleration. A linear ramp will give constant acceleration during ramping. An S-ramp will give non-linear acceleration. |
| [0] | Linear |
| [2] | S-ramp Const Time |
| | S-ramp based on the values set in 3-41 Ramp 1 Ramp Up Time and 3-42 Ramp 1 Ramp Down Time. |

| 3-41 Ramp 1 Ramp Up Time | | |
|--|-----------------|--|
| Range: | | Function: |
| Size related* | [0.05 - 3600 s] | Enter the ramp-up time, i.e. the acceleration time from 0 RPM to the synchronous motor speed n_s . Choose a ramp-up time such that the output current does not exceed the current limit in 4-18 <i>Current Limit</i> during ramping. The value 0.00 corresponds to 0.01 s in speed mode. See ramp-down time in 3-42 <i>Ramp 1 Ramp Down Time</i> . |
| $Par. 3 - 41 = \frac{t_{acc}[s] \times n_s [RPM]}{ref[RPM]}$ | | |

| 3-42 Ramp 1 Ramp Down Time | | |
|--|-----------------|---|
| Range: | | Function: |
| Size related* | [0.05 - 3600 s] | Enter the ramp-down time, that is, the deceleration time from the synchronous motor speed n_s to 0 RPM. Choose a ramp-down time such that no over-voltage arises in the inverter due to regenerative operation of the motor, and such that the generated current does not exceed the current limit set in 4-18 <i>Current Limit</i> . The value 0.00 corresponds to 0.01 s in speed mode. See ramp-up time in 3-41 <i>Ramp 1 Ramp Up Time</i> . |
| $Par. 3 - 42 = \frac{t_{dec}[s] \times n_s [RPM]}{ref[RPM]}$ | | |

3.4.4 3-5* Ramp 2

Choosing ramp parameters, see parameter group 3-4* *Ramp 1*.

| 3-50 Ramp 2 Type | | |
|------------------|----------------------|---|
| Option: | | Function: |
| [0] | Linear | Select the ramp type, depending on requirements for acceleration/deceleration. A linear ramp will give constant acceleration during ramping. An S-ramp will give non-linear acceleration. |
| [2] | S-ramp Const Time | S-ramp based on the values set in 3-41 <i>Ramp 1 Ramp Up Time</i> and 3-42 <i>Ramp 1 Ramp Down Time</i> . |

| 3-51 Ramp 2 Ramp Up Time | | |
|--------------------------|-----------------|--|
| Range: | | Function: |
| Size related* | [0.05 - 3600 s] | Enter the ramp-up time, i.e. the acceleration time from 0 RPM to the rated motor speed n_s . Choose a ramp-up time such that the output current does not exceed the current limit in 4-18 <i>Current Limit</i> during ramping. The value 0.00 corresponds to 0.01 s in speed mode. See ramp-down time in 3-52 <i>Ramp 2 Ramp Down Time</i> . |

| 3-51 Ramp 2 Ramp Up Time | | |
|--------------------------|--|--|
| Range: | | Function: |
| | | $Par. 3 - 51 = \frac{t_{acc}[s] \times n_s [RPM]}{ref[RPM]}$ |

| 3-52 Ramp 2 Ramp Down Time | | |
|----------------------------|-----------------|-----------|
| Range: | | Function: |
| Size related* | [0.05 - 3600 s] | |

3.4.5 3-8* Other Ramps

| 3-80 Jog Ramp Time | | |
|--------------------|-----------------|---|
| Range: | | Function: |
| Size related* | [0.05 - 3600 s] | Enter the jog ramp time, i.e. the acceleration/deceleration time between 0 RPM and the rated motor frequency n_s . Ensure that the resulting output current required for the given jog ramp time does not exceed the current limit in 4-18 <i>Current Limit</i> . The jog ramp time starts when activating a jog signal via the LCP, a selected digital output, or the serial communication port. When jog state is disabled, the normal ramping times are valid. |

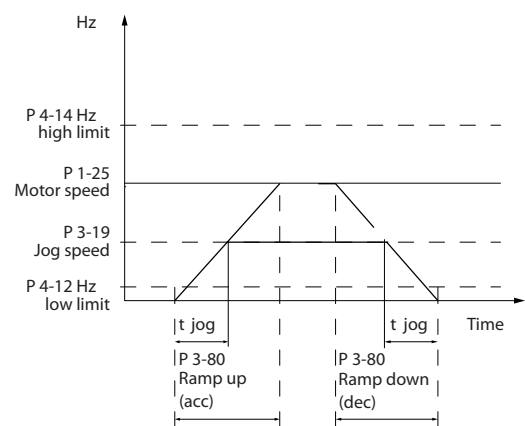

Illustration 3.9 Jog Ramp Time

$$Par. 3 - 80 = \frac{t_{jog}[s] \times n_s [RPM]}{\Delta \text{ jog speed } (par. 3 - 19) [RPM]}$$

| 3-81 Quick Stop Ramp Time | | |
|---------------------------|-----------------|--|
| Range: | | Function: |
| Size related* | [0.05 - 3600 s] | Enter the quick-stop ramp-down time, i.e. the deceleration time from the synchronous motor speed to 0 RPM. Ensure that no resultant over-voltage will arise in the inverter due to regenerative operation of the motor required to achieve the given ramp-down time. Ensure also that the generated current required to achieve the given ramp-down time does not exceed the |

| 3-81 Quick Stop Ramp Time | |
|---------------------------|--|
| Range: | Function: |
| | current limit (set in 4-18 Current Limit). Quick-stop is activated by means of a signal on a selected digital input, or via the serial communication port. |

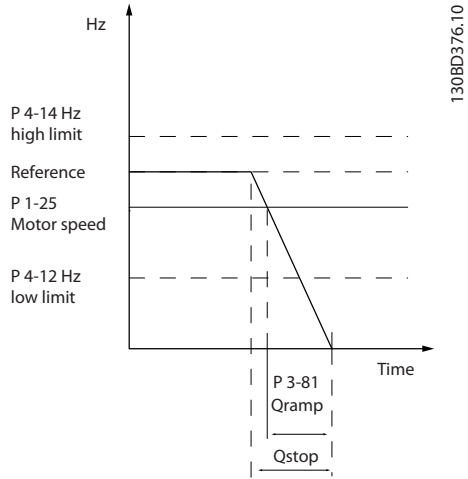

Illustration 3.10 Quick Stop Ramp Time

3.5 Parameters: 4-** Limits/Warnings

3.5.1 4-1* Motor Limits

3

Define torque, current and speed limits for the motor, and the reaction of the frequency converter when the limits are exceeded.

A limit may generate a message on the display. A warning will always generate a message on the display or on the fieldbus. A monitoring function may initiate a warning or a trip, upon which the frequency converter will stop and generate an alarm message.

| 4-10 Motor Speed Direction | | |
|----------------------------|-----------------|---|
| Option: | Function: | |
| [0] | Clockwise | Only operation in clockwise direction will be allowed. |
| [2] | Both directions | Operation in both clockwise and anti-clockwise direction will be allowed. |

NOTE

The setting in *4-10 Motor Speed Direction* has impact on *1-73 Flying Start*.

| 4-12 Motor Speed Low Limit [Hz] | | |
|---------------------------------|-----------------|--|
| Range: | Function: | |
| 0 Hz* | [0 - 400.0 Hz] | Enter the minimum limit for motor speed. The Motor Speed Low Limit can be set to correspond to the minimum output frequency of the motor shaft. The Motor Speed Low Limit must not exceed the setting in <i>4-14 Motor Speed High Limit [Hz]</i> . |

| 4-14 Motor Speed High Limit [Hz] | | |
|----------------------------------|-----------------|--|
| Range: | Function: | |
| 65 Hz* | [0.1 - 500 Hz] | <p>NOTE Max. output frequency cannot exceed 10% of the inverter switching frequency (<i>14-01 Switching Frequency</i>).</p> <p>Enter the maximum limit for motor speed. The Motor Speed High Limit can be set to correspond to the manufacturer's recommended maximum of the motor shaft. The Motor Speed High Limit must exceed the in <i>4-12 Motor Speed Low Limit [Hz]</i>.</p> |

| 4-16 Torque Limit Motor Mode | | |
|------------------------------|---------------|--|
| Range: | Function: | |
| Size related* | [0 - 1000 %] | This function limits the torque on the shaft to protect the mechanical installation. |

| 4-17 Torque Limit Generator Mode | | |
|----------------------------------|---------------|--|
| Range: | Function: | |
| 100 %* | [0 - 1000 %] | This function limits the torque on the shaft to protect the mechanical installation. |

| 4-18 Current Limit | | |
|--------------------|---------------|---|
| Range: | Function: | |
| Size related* | [0 - 1000 %] | <p>NOTE If [20] ATEX ETR is selected in <i>1-90 Motor Thermal Protection</i>, <i>4-18 Current Limit</i> current limit must be set to 150%.</p> <p>This is a true current limit function that continues in the oversynchronous range, however due to field weakening the motor torque at current limit will drop accordingly when the voltage increase stops above the synchronised speed of the motor.</p> |

| 4-19 Max Output Frequency | | |
|---------------------------|---------------|---|
| Range: | Function: | |
| 65 Hz* | [0 - 500 Hz] | <p>NOTE This parameter cannot be adjusted while the motor is running.</p> <p>NOTE Max. output frequency cannot exceed 10% of the inverter switching frequency (<i>14-01 Switching Frequency</i>).</p> <p>Provides a final limit on the output frequency for improved safety in applications where you want to avoid accidental over-speeding. This limit is final in all configurations (independent of the setting in <i>1-00 Configuration Mode</i>).</p> |

| 4-22 Break Away Boost | | |
|-----------------------|-----------|--|
| Option: | Function: | |
| [0] | Off | |
| [1] | On | |

| 4-30 Motor Feedback Loss Function | |
|-----------------------------------|--|
| Option: | Function: |
| | <p>NOTE Warning 90 is active as soon as the value in 4-31 Motor Feedback Speed Error is exceeded, regardless of the setting in 4-32 Motor Feedback Loss Timeout. Warning/Alarm 61 Feedback error is related to the motor feedback loss-function.</p> <p>This function is used to monitor for consistency in feedback signal, i.e. if the feedback signal is available. Select which reaction the frequency converter should take if a feedback fault is detected. The selected action takes place when the feedback signal differs from the output speed by the value set in 4-31 Motor Feedback Speed Error for longer than the value set in 4-32 Motor Feedback Loss Timeout.</p> |
| [0] | Disabled |
| [1] | Warning |
| [2] | Trip |
| [3] | Jog |
| [4] | Freeze Output |
| [5] | Max Speed |
| [6] | Switch to Open Loop |

| 4-31 Motor Feedback Speed Error | |
|---------------------------------|--|
| Range: | Function: |
| 20 Hz* | [0 - 50 Hz] Select the max allowed error in speed (output speed vs. feedback). |

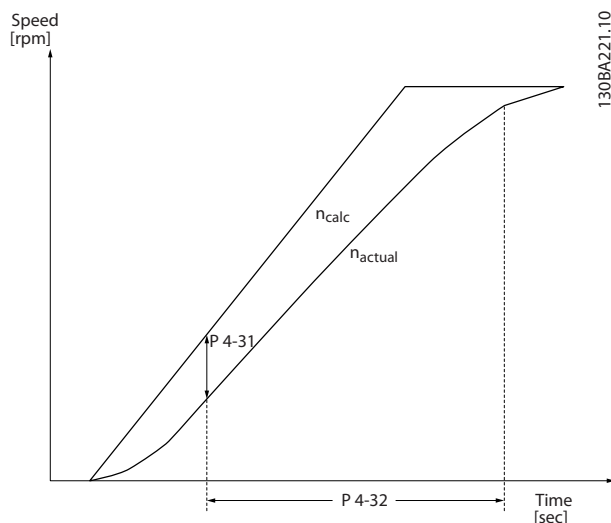

Illustration 3.11 Motor Feedback Speed Error

| 4-32 Motor Feedback Loss Timeout | |
|----------------------------------|---|
| Range: | Function: |
| 0.05 s* | [0 - 60 s] Set the timeout value allowing the speed error set in 4-31 Motor Feedback Speed Error to be exceeded before enabling the function selected in 4-30 Motor Feedback Loss Function. |

3.5.2 4-4* Adjustable Warnings 2

| 4-40 Warning Freq. Low | |
|------------------------|--|
| Range: | Function: |
| Size related* | [0 - 400 Hz] Use this parameter for setting a lower limit for the frequency range. When the motor speed falls below this limit, the display reads <i>Speed low</i> . Warning bit 10 is set in 16-94 Ext. Status Word. Output relay can be configured to indicate this warning. LCP warning light is not lit when the limit set is reached. |

| 4-41 Warning Freq. High | |
|-------------------------|---|
| Range: | Function: |
| Size related* | [0 - 400 Hz] Use this parameter for setting a higher limit for the frequency range. When the motor speed exceeds this limit, the display reads <i>Speed high</i> . Warning bit 9 is set in 16-94 Ext. Status Word. Output relay can be configured to indicate this warning. LCP warning light is not lit when the limit set is reached. |

| 4-42 Adjustable Temperature Warning | |
|-------------------------------------|------------|
| Range: | Function: |
| 0 * | [0 - 255] |

3.5.3 4-5* Adjustable Warnings

Use these parameters to adjust warning limits for current, speed, reference and feedback.

| 4-50 Warning Current Low | |
|--------------------------|---|
| Range: | Function: |
| 0 A* | [0 - 194.0 A] Enter the I _{LOW} value. When the motor current falls below this limit, a bit in the drives statusword will be set. This value can also be programmed to produce a signal on the digital output or the relay output. |

| 4-51 Warning Current High | | |
|---------------------------|-------------------|---|
| Range: | | Function: |
| Size related* | [0.0 - 194.0 A] | Enter the I_{HIGH} value. When the motor current exceeds this limit, a bit in the drives statusword will be set. This value can also be programmed to produce a signal on the digital output or the relay output. |

| 4-54 Warning Reference Low | | |
|----------------------------|-----------------|---|
| Range: | | Function: |
| -4999 * | [-4999 - 4999] | Enter the lower reference limit. When the actual reference falls below this limit, the display reads Ref_{LOW} . The signal outputs can be programmed to produce a status signal on terminal 27 or 29 and on relay output 01 or 02. |

| 4-55 Warning Reference High | | |
|-----------------------------|-----------------|--|
| Range: | | Function: |
| 4999 * | [-4999 - 4999] | Enter the upper reference limit. When the actual reference exceeds this limit, the display reads Ref_{HIGH} . The signal outputs can be programmed to produce a status signal on terminal 27 or 29 and on relay output 01 or 02. |

| 4-56 Warning Feedback Low | | |
|---------------------------|--------------------------------|---|
| Range: | | Function: |
| -4999 ProcessCtrlUnit* | [-4999 - 4999 ProcessCtrlUnit] | Enter the lower feedback limit. When the feedback falls below this limit, the display reads Feedb Low. The signal outputs can be programmed to produce a status signal on terminal 27 or 29 and on relay output 01 or 02. |

| 4-57 Warning Feedback High | | |
|----------------------------|--------------------------------|--|
| Range: | | Function: |
| 4999 ProcessCtrlUnit* | [-4999 - 4999 ProcessCtrlUnit] | Enter the upper feedback limit. When the feedback exceeds this limit, the display reads Feedb High. The signal outputs can be programmed to produce a status signal on terminal 27 or 29 and on relay output 01 or 02. |

| 4-58 Missing Motor Phase Function | | |
|--|-----|--|
| Option: | | Function: |
| NOTE This parameter cannot be adjusted while the motor is running. Missing Motor phase Function is always disabled with PM. Select On, to display an alarm in the event of a missing motor phase. Select Off, for no missing motor phase alarm. However the On setting is strongly recommended to avoid motor damage. | | |
| [0] | Off | No alarm is displayed if a missing motor phase occurs. |
| [1] | On | An alarm is displayed if a missing motor phase occurs. |

| 4-61 Bypass Speed From [Hz] | | |
|-----------------------------|----------------|---|
| Range: | | Function: |
| 0 Hz* | [0 - 500 Hz] | Some systems call for avoiding certain output speeds due to resonance problems in the system. Enter the lower limits of the speeds to be avoided. |

| 4-63 Bypass Speed To [Hz] | | |
|---------------------------|----------------|---|
| Range: | | Function: |
| 0 Hz* | [0 - 500 Hz] | Some systems call for avoiding certain output speeds due to resonance problems in the system. Enter the upper limits of the speeds to be avoided. |

3.6 Parameters: 5-** Digital In/Out

3.6.1 5-0* Digital I/O Mode

Parameters for configuring the input and output using NPN and PNP.

NOTE

These parameters cannot be adjusted while the motor is running.

| 5-00 Digital Input Mode | | |
|-------------------------|-----------|---|
| Option: | Function: | |
| | | Set NPN or PNP mode for digital inputs 18,19 and 27. Digital Input Mode |
| [0] | PNP | Action on positive directional pulses (0). PNP systems are pulled down to GND. |
| [1] | NPN | Action on negative directional pulses (1). NPN systems are pulled up to +24 V, internally in the frequency converter. |

| 5-01 Terminal 27 Mode | | |
|-----------------------|-----------|--|
| Option: | Function: | |
| | | NOTE This parameter cannot be adjusted while the motor is running. |
| [0] | Input | Defines terminal 27 as a digital input. |
| [1] | Output | Defines terminal 27 as a digital output. |

| 5-02 Terminal 29 Mode | | |
|-----------------------|-----------|--|
| Option: | Function: | |
| | | NOTE This parameter cannot be adjusted while the motor is running. |
| [0] | Input | Defines terminal 29 as a digital input. |
| [1] | Output | Defines terminal 29 as a digital output. |

3.6.2 5-1* Digital Inputs

The digital inputs are used for selecting various functions in the frequency converter.

5-10 to 5-16 Digital Inputs

| | | |
|-----|---------------|---|
| [0] | No operation | No reaction to signals transmitted to the terminal. |
| [1] | Reset | Resets frequency converter after a TRIP/ALARM. Not all alarms can be reset. |
| [2] | Coast inverse | (Default Digital input 27): Coasting stop, inverted input (NC). The frequency converter |

| | | |
|------|-------------------------|--|
| | | leaves the motor in free mode. Logic '0' =>coasting stop. |
| [3] | Coast and reset inverse | Reset and coasting stop Inverted input (NC). Leaves motor in free mode and resets frequency converter. Logic '0' => coasting stop and reset. |
| [4] | Quick stop inverse | Inverted input (NC). Generates a stop in accordance with quick-stop ramp time set in 3-81 <i>Quick Stop Ramp Time</i> . When motor stops, the shaft is in free mode. Logic '0' => Quick-stop. |
| [5] | DC-brake inverse | Inverted input for DC braking (NC). Stops motor by energizing it with a DC current for a certain time period. See 2-01 <i>DC Brake Current</i> to 2-03 <i>DC Brake Cut In Speed [RPM]</i> . The function is only active when the value in 2-02 <i>DC Braking Time</i> is different from 0. Logic '0' => DC braking. |
| [6] | Stop inverse | Stop Inverted function. Generates a stop function when the selected terminal goes from logical level '1' to '0'. The stop is performed according to the selected ramp time (3-42 <i>Ramp 1 Ramp Down Time</i> , 3-52 <i>Ramp 2 Ramp Down Time</i>). NOTE When the frequency converter is at the torque limit and has received a stop command, it may not stop by itself. To ensure that the frequency converter stops, configure a digital output to <i>Torque limit & stop [27]</i> and connect this digital output to a digital input that is configured as coast. |
| [8] | Start | (Default Digital input 18): Select start for a start/stop command. Logic '1' = start, logic '0' = stop. |
| [9] | Latched start | The motor starts, if a pulse is applied for min. 2 ms. The motor stops when Stop inverse is activated or a reset command (via DI) is given. |
| [10] | Reversing | (Default Digital input 19). Change the direction of motor shaft rotation. Select Logic '1' to reverse. The reversing signal only changes the direction of rotation. It does not activate the start function. Select both directions in 4-10 <i>Motor Speed Direction</i> . The function is not active in process closed loop. |
| [11] | Start reversing | Used for start/stop and for reversing on the same wire. Signals on start are not allowed at the same time. |
| [12] | Enable start forward | Disengages the counterclockwise movement and allows for the clockwise direction. |
| [13] | Enable start reverse | Disengages the clockwise movement and allows for the counterclockwise direction. |
| [14] | Jog | (Default Digital input 29): Use to activate jog speed. See 3-11 <i>Jog Speed [Hz]</i> . |

| | | |
|------|---------------------|--|
| [15] | Preset reference on | Shifts between external reference and preset reference. It is assumed that [1] <i>External/preset</i> has been selected in 3-04 <i>Reference Function</i> . Logic '0' = external reference active; logic '1' = one of the eight preset references is active. |
| [16] | Preset ref bit 0 | Preset ref. bit 0,1, and 2 enables a choice between one of the eight preset references according to <i>Table 3.3</i> . |
| [17] | Preset ref bit 1 | Same as Preset ref bit 0 [16]. |
| [18] | Preset ref bit 2 | Same as Preset ref bit 0 [16]. |

| Preset ref. bit | 2 | 1 | 0 |
|-----------------|---|---|---|
| Preset ref. 0 | 0 | 0 | 0 |
| Preset ref. 1 | 0 | 0 | 1 |
| Preset ref. 2 | 0 | 1 | 0 |
| Preset ref. 3 | 0 | 1 | 1 |
| Preset ref. 4 | 1 | 0 | 0 |
| Preset ref. 5 | 1 | 0 | 1 |
| Preset ref. 6 | 1 | 1 | 0 |
| Preset ref. 7 | 1 | 1 | 1 |

Table 3.2 Preset Ref. Bit

| | | |
|------|---------------|---|
| [19] | Freeze ref | Freezes the actual reference, which is now the point of enable/condition for Speed up and Speed down to be used. If Speed up/down is used, the speed change always follows ramp 2 (3-51 <i>Ramp 2 Ramp Up Time</i> and 3-52 <i>Ramp 2 Ramp Down Time</i>) in the range 0 - 3-03 <i>Maximum Reference</i> . |
| [20] | Freeze output | Freezes the actual motor frequency (Hz), which is now the point of enable/condition for Speed up and Speed down to be used. If Speed up/down is used, the speed change always follows ramp 2 (3-51 <i>Ramp 2 Ramp Up Time</i> and 3-52 <i>Ramp 2 Ramp Down Time</i>) in the range 0 - 1-23 <i>Motor Frequency</i> . NOTE When Freeze output is active, the frequency converter cannot be stopped via a low 'start [8]' signal. Stop the frequency converter via a terminal programmed for Coasting inverse [2] or Coast and reset, inverse. |
| [21] | Speed up | Select Speed up and Speed down if digital control of the up/down speed is desired (motor potentiometer). Activate this function by selecting either Freeze reference or Freeze output. When Speed up/down is activated for less than 400 ms the resulting reference will be increased/ decreased by 0.1 %. If Speed up/down is activated for more than 400 ms the resulting reference will follow the setting in ramping up/down parameter 3-x1/ 3-x2. |

| | Shut down | Catch up |
|----------------------|-----------|----------|
| Unchanged speed | 0 | 0 |
| Reduced by %-value | 1 | 0 |
| Increased by %-value | 0 | 1 |
| Reduced by %-value | 1 | 1 |

Table 3.3 Shut Down/Catch Up

| | | |
|------|---------------------|---|
| [22] | Speed down | Same as [21] <i>Speed up</i> . |
| [23] | Set-up select bit 0 | Select Set-up select bit 0 or Select Set-up select bit 1 to select one of the 2 set-ups. Set 0-10 <i>Active Set-up</i> to Multi Set-up. |
| [24] | Set-up select bit 1 | (Default Digital input 32): Same as [23] <i>Set-up select bit 0</i> . |
| [26] | Precise stop inv. | Precise stop inverse function is available for terminals 18 or 19. |
| [28] | Catch up | Increases reference value by percentage (relative) set in 3-12 <i>Catch up/slow Down Value</i> . |
| [29] | Slow down | Reduces reference value by percentage (relative) set in 3-12 <i>Catch up/slow Down Value</i> . |
| [34] | Ramp bit 0 | Enables a choice between one of the 4 ramps available, according to <i>Table 3.5</i> . |

| Preset ramp bit | 1 | 0 |
|-----------------|---|---|
| Ramp 1 | 0 | 0 |
| Ramp 2 | 0 | 1 |
| Ramp 3 | 1 | 0 |
| Ramp 4 | 1 | 1 |

Table 3.4 Preset Ramp Bit

| | | |
|------|--------------------|---|
| [51] | External interlock | This function makes it possible to give an external fault to the frequency converter. This fault is treated in the same way as an internally generated alarm. |
| [60] | Counter A | (Terminal 29 or 33 only) Input for increment counting in the SLC counter. |
| [61] | Counter A | (Terminal 29 or 33 only) Input for decrement counting in the SLC counter. |
| [62] | Reset Counter A | Input for reset of counter A. |
| [63] | Counter B | (Terminal 29 or 33 only) Input for increment counting in the SLC counter. |
| [64] | Counter B | (Terminal 29 or 33 only) Input for decrement counting in the SLC counter. |
| [65] | Reset Counter B | Input for reset of counter B. |
| [72] | PID error inverse | When enabled, it inverts the resulting error from the process PID controller. Available only if "Configuration Mode" is set to "Surface Winder" or "Extended PID Speed OL". |
| [73] | PID reset I-part | When enabled, resets the I-part of the Process PID controller. Equivalent to 7-40 <i>Process PID I-part Reset</i> . Available only if |

| | | |
|------|------------|---|
| | | "Configuration Mode" is set to "Surface Winder" or "Extended PID Speed OL". |
| [74] | PID enable | When enabled, enables the extended process PID controller. Equivalent to <i>7-50 Process PID Extended PID</i> . Available only if "Configuration Mode" is set to "Extended PID Speed OL". |

Besides the selections above, default value and some extra selections for specific terminals as below.

5-10 Terminal 18 Digital Input

Option: Function:

| | | |
|-------|-------|---|
| [8] * | Start | Functions are described in parameter group <i>5-1* Digital Inputs</i> . |
|-------|-------|---|

5-11 Terminal 19 Digital Input

Option: Function:

| | | |
|--------|-----------|---|
| [10] * | Reversing | Functions are described in parameter group <i>5-1* Digital Inputs</i> . |
|--------|-----------|---|

5-12 Terminal 27 Digital Input

Option: Function:

| | | |
|-------|---------------|---|
| [2] * | Coast inverse | Functions are described in parameter group <i>5-1* Digital Inputs</i> . |
|-------|---------------|---|

5-13 Terminal 29 Digital Input

Option: Function:

| | | |
|--------|------------------|---|
| [14] * | Jog | Functions are described in parameter group <i>5-1* Digital Inputs</i> . |
| [32] | Pulse time based | |

5-14 Terminal 32 Digital Input

Option: Function:

| | | |
|-------|-----------------|---|
| [0] * | No operation | Functions are described in parameter group <i>5-1* Digital Inputs</i> . |
| [82] | Encoder input B | |

5-15 Terminal 33 Digital Input

Option: Function:

| | | |
|-------|------------------|---|
| [0] * | No operation | Functions are described in parameter group <i>5-1* Digital Inputs</i> . |
| [32] | Pulse time based | |
| [81] | Encoder input A | |

5-16 Terminal 31 Digital Input

Option: Function:

| | | |
|-----|--------------|---|
| [0] | No operation | Functions are described in parameter group <i>5-1* Digital Inputs</i> . |
|-----|--------------|---|

3.6.3 5-3* Digital Outputs

The 2 solid-state digital outputs are common for terminals 27 and 29. Set the I/O function for terminal 27 in *5-01 Terminal 27 Mode*, and set the I/O function for terminal 29 in *5-02 Terminal 29 Mode*.

Terminals 42 and 45 can also be configured as digital outputs.

NOTE

These parameters cannot be adjusted while the motor is running.

5-30 to 5-31 Digital Outputs

| | | |
|------|-------------------------------|---|
| [0] | No operation | Default for all digital outputs and relay outputs. |
| [1] | Control ready | The control card is ready. |
| [2] | Drive ready | The frequency converter is ready for operation and applies a supply signal on the control board. |
| [3] | Drive ready / remote control | The frequency converter is ready for operation and is in [Auto On] mode. |
| [4] | Enable / no warning | Ready for operation. No start or stop command is been given (start/disable). No warnings are active. |
| [5] | Running | Motor is running and shaft torque present. |
| [6] | Running / no warning | Output speed is higher than the speed set in <i>1-81 Min Speed for Function at Stop [RPM]</i> . The motor is running and there are no warnings. |
| [7] | Run in range / no warning | Motor is running within the programmed current and speed ranges set in <i>4-50 Warning Current Low</i> to <i>4-51 Warning Current High</i> . There are no warnings. |
| [8] | Run on reference / no warning | Motor runs at reference speed. No warnings. |
| [9] | Alarm | An alarm activates the output. There are no warnings. |
| [10] | Alarm or warning | An alarm or a warning activates the output. |
| [11] | At torque limit | The torque limit set in <i>4-16 Torque Limit Motor Mode</i> or <i>4-17 Torque Limit Generator Mode</i> has been exceeded. |
| [12] | Out of current range | The motor current is outside the range set in <i>4-18 Current Limit</i> . |
| [13] | Below current, low | Motor current is lower than set in <i>4-50 Warning Current Low</i> . |
| [14] | Above current, high | Motor current is higher than set in <i>4-51 Warning Current High</i> . |
| [15] | Out of frequency range | Output frequency is outside the frequency range. |
| [16] | Below frequency, low | Output speed is lower than the setting in <i>4-40 Warning Freq. Low</i> . |
| [17] | Above frequency, high | Output speed is higher than the setting in <i>4-41 Warning Freq. High</i> . |
| [18] | Out of feedback range | Feedback is outside the range set in <i>4-56 Warning Feedback Low</i> and <i>4-57 Warning Feedback High</i> . |

| | | |
|------|-----------------------------------|---|
| [19] | Below feedback low | Feedback is below the limit set in 4-56 <i>Warning Feedback Low</i> . |
| [20] | Above feedback high | Feedback is above the limit set in 4-57 <i>Warning Feedback High</i> . |
| [21] | Thermal warning | The thermal warning turns on when the temperature exceeds the limit in the motor, the frequency converter, the brake resistor, or the thermistor. |
| [22] | Ready, no thermal warning | Frequency converter is ready for operation and there is no over-temperature warning. |
| [23] | Remote, ready, no thermal warning | Frequency converter is ready for operation and is in [Auto On] mode. There is no over-temperature warning. |
| [24] | Ready, no over-/under voltage | Frequency converter is ready for operation and the mains voltage is within the specified voltage range (see <i>General Specifications</i> section in the Design Guide). |
| [25] | Reverse | The motor runs (or is ready to run) clockwise when logic=0 and counter clockwise when logic=1. The output changes as soon as the reversing signal is applied. |
| [26] | Bus OK | Active communication (no time-out) via the serial communication port. |
| [27] | Torque limit and stop | Use in performing a coasting stop and in torque limit condition. If the frequency converter has received a stop signal and is at the torque limit, the signal is Logic '0'. |
| [28] | Brake, no brake warning | Brake is active and there are no warnings. |
| [29] | Brake ready, no fault | Brake is ready for operation and there are no faults. |
| [30] | Brake fault (IGBT) | Output is Logic '1' when the brake IGBT is short-circuited. Use this function to protect the frequency converter if there is a fault on the brake modules. Use the output/relay to cut out the main voltage from the frequency converter. |
| [31] | Relay 123 | Relay is activated when Control Word [0] is selected in parameter group 8-** <i>Communications and Options</i> . |
| [32] | Mechanical brake control | Enables control of an external mechanical brake, see description in the section <i>Control of Mechanical Brake</i> , and parameter group 2-2* <i>Mechanical Brake</i> |
| [31] | Relay 123 | |
| [32] | Mech brake ctrl | |
| [36] | Control word bit 11 | |
| [37] | Control word bit 12 | |

| | | |
|------|----------------------------------|--|
| [40] | Out of ref range | Active when the actual speed is outside settings in 4-52 <i>Warning Speed Low</i> to 4-55 <i>Warning Reference High</i> . |
| [41] | Below reference low | Active when actual speed is below speed reference setting. |
| [42] | Above reference high | Active when actual speed is above speed reference setting |
| [45] | Bus Ctrl | Controls output via bus. The state of the output is set in 5-90 <i>Digital & Relay Bus Control</i> . The output state is retained in the event of bus time-out. |
| [46] | Bus Ctrl On at timeout | Controls output via bus. The state of the output is set in 5-90 <i>Digital & Relay Bus Control</i> . In the event of bus time-out the output state is set high (On). |
| [55] | Pulse output | |
| [56] | Heat sink cleaning warning, high | |
| [60] | Comparator 0 | See parameter group 13-1* <i>Comparators</i> . If Comparator 0 is evaluated as TRUE, the output will go high. Otherwise, it will be low. |
| [61] | Comparator 1 | See parameter group 13-1* <i>Comparators</i> . If Comparator 1 is evaluated as TRUE, the output will go high. Otherwise, it will be low. |
| [62] | Comparator 2 | See parameter group 13-1* <i>Comparators</i> . If Comparator 2 is evaluated as TRUE, the output will go high. Otherwise, it will be low. |
| [63] | Comparator 3 | See parameter group 13-1* <i>Comparators</i> . If Comparator 3 is evaluated as TRUE, the output will go high. Otherwise, it will be low. |
| [64] | Comparator 4 | See parameter group 13-1* <i>Comparators</i> . If Comparator 4 is evaluated as TRUE, the output will go high. Otherwise, it will be low. |
| [65] | Comparator 5 | See parameter group 13-1* <i>Comparators</i> . If Comparator 5 is evaluated as TRUE, the output will go high. Otherwise, it will be low. |
| [70] | Logic Rule 0 | See parameter group 13-4* <i>Logic Rules</i> . If Logic Rule 0 is evaluated as TRUE, the output will go high. Otherwise, it will be low. |
| [71] | Logic Rule 1 | See parameter group 13-4* <i>Logic Rules</i> . If Logic Rule 1 is evaluated as TRUE, the output will go high. Otherwise, it will be low. |
| [72] | Logic Rule 2 | See parameter group 13-4* <i>Logic Rules</i> . If Logic Rule 2 is evaluated as TRUE, the output will go high. Otherwise, it will be low. |
| [73] | Logic Rule 3 | See parameter group 13-4* <i>Logic Rules</i> . If Logic Rule 3 is evaluated as TRUE, the |

| | | |
|-------|------------------------|---|
| | | output will go high. Otherwise, it will be low. |
| [74] | Logic Rule 4 | See parameter group 13-4* <i>Logic Rules</i> . If Logic Rule 4 is evaluated as TRUE, the output will go high. Otherwise, it will be low. |
| [75] | Logic Rule 5 | See parameter group 13-4* <i>Logic Rules</i> . If Logic Rule 5 is evaluated as TRUE, the output will go high. Otherwise, it will be low. |
| [80] | SL Digital Output A | See 13-52 <i>SL Controller Action</i> . The output will go high whenever the Smart Logic Action [38] <i>Set dig. out. A high</i> is executed. The output will go low whenever the Smart Logic Action [32] <i>Set dig. out. A low</i> is executed. |
| [81] | SL Digital Output B | See 13-52 <i>SL Controller Action</i> . The input will go high whenever the Smart Logic Action [39] <i>Set dig. out. B high</i> is executed. The input will go low whenever the Smart Logic Action [33] <i>Set dig. out. B low</i> is executed. |
| [82] | SL Digital Output C | See 13-52 <i>SL Controller Action</i> . The input will go high whenever the Smart Logic Action [40] <i>Set dig. out. C high</i> is executed. The input will go low whenever the Smart Logic Action [34] <i>Set dig. out. C low</i> is executed. |
| [83] | SL Digital Output D | See 13-52 <i>SL Controller Action</i> . The input will go high whenever the Smart Logic Action [41] <i>Set dig. out. D high</i> is executed. The input will go low whenever the Smart Logic Action [35] <i>Set dig. out. D low</i> is executed. |
| [160] | No alarm | The output is high when no alarm is present. |
| [161] | Running reverse | The output is high when the frequency converter is running counter clockwise (the logical product of the status bits 'running' AND 'reverse'). |
| [165] | Local reference active | |
| [166] | Remote ref active | |
| [167] | Start command activ | The output is high when there is an active start command and no stop command is active. |
| [168] | Drive in hand mode | The output is high when the frequency converter is in Hand on mode. |
| [169] | Drive in auto mode | The output is high when the frequency converter is in Auto mode. |
| [193] | Sleep mode | The frequency converter/system has turned into sleep mode. See parameter group 22-4* <i>Sleep Mode</i> . |
| [194] | Broken belt | A broken belt condition has been detected See parameter group 22-4* <i>Sleep Mode</i> . |

5-31 Terminal 29 Digital Output

| Option: | Function: |
|------------------|--|
| [0] No operation | Functions are described in parameter group 5-3* <i>Digital Outputs</i> . |

5-34 On Delay, Digital Output

| Range: | Function: |
|---------|-------------|
| 0.01 s* | [0 - 600 s] |

5-35 Off Delay, Digital Output

| Range: | Function: |
|---------|-------------|
| 0.01 s* | [0 - 600 s] |

3.6.4 5-4* Relays

Parameters for configuring the timing and the output functions for the relays.

The parameter is an array parameter representing 2 relays.

5-40 Function Relay

| Option: | Function: |
|---------------------------|--|
| [0] No operation | Default setting for all digital and relay outputs. |
| [1] Control Ready | The control card is ready. |
| [2] Drive ready | The frequency converter is ready to operate. Mains and control supplies are OK. |
| [3] Drive rdy/rem ctrl | The frequency converter is ready for operation and is in Auto On mode. |
| [4] Stand-by / no warning | Ready for operation. No start or stop commands have been applied. No warnings are active. |
| [5] Running | The motor is running and a shaft torque is present. |
| [6] Running / no warning | Output speed is higher than the speed set in 1-82 <i>Min Speed for Function at Stop [Hz]</i> . The motor is running and no warnings are present. |
| [7] Run in range/no warn | The motor is running within the programmed current ranges set in 4-50 <i>Warning Current Low</i> . |
| [8] Run on ref/no warn | Motor runs at reference speed. No warnings. |
| [9] Alarm | An alarm activates the output. No warnings. |
| [10] Alarm or warning | An alarm or warning activates the output. |
| [11] At torque limit | The torque limit set in 4-16 <i>Torque Limit Motor Mode</i> or 4-17 <i>Torque</i> |

| 5-40 Function Relay | | |
|---------------------|-------------------------------|---|
| Option: | Function: | |
| | | <i>Limit Generator Mode</i> has been exceeded. |
| [12] | Out of current range | The motor current is outside the range set in <i>4-18 Current Limit</i> . |
| [13] | Below current, low | Motor current is lower than set in <i>4-50 Warning Current Low</i> . |
| [14] | Above current, high | Motor current is higher than set in <i>4-51 Warning Current High</i> . |
| [15] | Out of frequency range | Output speed/frequency is outside set in <i>4-40 Warning Freq. Low</i> and <i>4-41 Warning Freq. High</i> . |
| [16] | Below frequency, low | Output frequency is lower than the setting in <i>4-40 Warning Freq. Low</i> . |
| [17] | Above frequency, high | The frequency is higher than the setting in <i>4-41 Warning Freq. High</i> . |
| [18] | Out of feedb. range | Feedback is outside the range set in <i>4-56 Warning Feedback Low</i> and <i>4-57 Warning Feedback High</i> . |
| [19] | Below feedback, low | Feedback is below the limit set in <i>4-56 Warning Feedback Low</i> . |
| [20] | Above feedback, high | Feedback is above the limit set in <i>4-57 Warning Feedback High</i> . |
| [21] | Thermal warning | Thermal warning turns on when the temperature exceeds the limit wither in motor, frequency converter, brake resistor or connected resistor. |
| [22] | Ready, no thermal warning | The frequency converter is ready for operation and there is no overtemperature warning. |
| [23] | Remote,ready,no TW | The frequency converter is ready for operation and is in Auto On mode. There is no overtemperature warning. |
| [24] | Ready, no over-/under voltage | The frequency converter is ready for operation and the mains voltage is within the specified voltage range. |
| [25] | Reverse | The motor runs (or is ready to run) clockwise when logic=0 and counter clockwise when logic=1. The output changes as soon as the reversing signal is applied. |
| [26] | Bus OK | Active communication (no time-out) via the serial communication port. |
| [27] | Torque limit & stop | Use for performing a coasted stop and frequency converter in torque limit condition. If the frequency converter has received a stop signal |

| 5-40 Function Relay | | |
|---------------------|-------------------------|--|
| Option: | Function: | |
| | | and is in torque limit, the signal is logic=0. |
| [28] | Brake, no brake warning | Brake is active and there are no warnings. |
| [29] | Brake ready, no fault | Brake is ready for operation and there are no faults. |
| [30] | Brake fault (IGBT) | Output is logic=1 when the brake IGBT is short-circuited. Use this function to protect the frequency converter if there is a fault on the brake module. Use the digital output/relay to cut out the mains voltage from the frequency converter. |
| [31] | Relay 123 | Digital output/relay is activated when [0] <i>Control word</i> is selected in parameter group 8-*** <i>Communications</i> . |
| [32] | Mech brake ctrl | Selection of mechanical brake control. When selected parameters in parameter group 2-2* <i>Mechanical brake</i> are active. The output must be reinforced to carry the current for the coil in the brake. Usually solved by connecting an external relay to the selected digital output. |
| [36] | Control word bit 11 | Activate relay 1 by control word from fieldbus. No other functional impact in the frequency converter. Typical application: Controlling auxillary device from fieldbus. The function is valid when [0] <i>FC Profile</i> is selected in 8-10 <i>Control Word Profile</i> . |
| [37] | Control word bit 12 | Activate relay 2 by control word from fieldbus. No other functional impact in the frequency converter. Typical application: Controlling auxillary device from fieldbus. The function is valid when [0] <i>FC Profile</i> is selected in 8-10 <i>Control Word Profile</i> . |
| [40] | Out of ref range | Active when the actual speed is outside the settings in <i>4-55 Warning Reference High</i> and <i>4-56 Warning Feedback Low</i> . |
| [41] | Below reference, low | Active when the actual speed is below speed reference setting. |
| [42] | Above ref, high | Active when actual speed is above speed reference setting. |

| 5-40 Function Relay | | |
|---------------------|----------------------------------|---|
| Option: | Function: | |
| [45] | Bus ctrl. | Controls digital output/relay via bus. The state of the output is set in <i>5-90 Digital & Relay Bus Control</i> . The output state is retained in the event of bus time-out. |
| [46] | Bus control, timeout: On | Controls output via bus. The state of the output is set in <i>5-90 Digital & Relay Bus Control</i> . In the event of bus time-out, the output state is set high (on). |
| [47] | Bus control, timeout: Off | Controls output via bus. The state of the output is set in <i>5-90 Digital & Relay Bus Control</i> . In the event of bus time-out, the output state is set low (off). |
| [56] | Heat sink cleaning warning, high | |
| [60] | Comparator 0 | See parameter group <i>13-1* Smart Logic Control</i> . If Comparator 0 in SLC is TRUE, the output goes high. Otherwise, it goes low. |
| [61] | Comparator 1 | See parameter group <i>13-1* Smart Logic Control</i> . If Comparator 1 in SLC is TRUE, the output goes high. Otherwise, it goes low. |
| [62] | Comparator 2 | See parameter group <i>13-1* Smart Logic Control</i> . If Comparator 2 in SLC is TRUE, the output goes high. Otherwise, it goes low. |
| [63] | Comparator 3 | See parameter group <i>13-1* Smart Logic Control</i> . If Comparator 3 in SLC is TRUE, the output goes high. Otherwise, it goes low. |
| [64] | Comparator 4 | See parameter group <i>13-1* Smart Logic Control</i> . If Comparator 4 in SLC is TRUE, the output goes high. Otherwise, it goes low. |
| [65] | Comparator 5 | See parameter group <i>13-1* Smart Logic Control</i> . If Comparator 5 in SLC is TRUE, the output goes high. Otherwise, it goes low. |
| [70] | Logic rule 0 | See parameter group <i>13-4* Logic Rules</i> . If Logic Rule 0 in SLC is TRUE, the output goes high. Otherwise, it goes low. |
| [71] | Logic rule 1 | See parameter group <i>13-4* Logic Rules</i> . If Logic Rule 1 in SLC is TRUE, the output goes high. Otherwise, it goes low. |

| 5-40 Function Relay | | |
|---------------------|----------------------|--|
| Option: | Function: | |
| [72] | Logic rule 2 | See parameter group <i>13-4* Logic Rules</i> . If Logic Rule 2 in SLC is TRUE, the output goes high. Otherwise, it goes low. |
| [73] | Logic rule 3 | See parameter group <i>13-4* Logic Rules</i> . If Logic Rule 3 in SLC is TRUE, the output goes high. Otherwise, it goes low. |
| [74] | Logic rule 4 | See parameter group <i>13-4* Logic Rules</i> . If Logic Rule 4 in SLC is TRUE, the output goes high. Otherwise, it goes low. |
| [75] | Logic rule 5 | See parameter group <i>13-4* Logic Rules</i> . If Logic Rule 5 in SLC is TRUE, the output goes high. Otherwise, it goes low. |
| [80] | SL digital output A | See <i>13-52 SL Controller Action</i> . Output A is low on <i>[32] Smart Logic Action</i> . Output A is high on <i>[38] Smart Logic Action</i> . |
| [81] | SL digital output B | See <i>13-52 SL Controller Action</i> . Output B is low on <i>[32] Smart Logic Action</i> . Output B is high on <i>[38] Smart Logic Action</i> . |
| [82] | SL digital output C | See <i>13-52 SL Controller Action</i> . Output C is low on <i>[32] Smart Logic Action</i> . Output C is high on <i>[38] Smart Logic Action</i> . |
| [83] | SL digital output D | See <i>13-52 SL Controller Action</i> . Output D is low on <i>[32] Smart Logic Action</i> . Output D is high on <i>[38] Smart Logic Action</i> . |
| [160] | No alarm | |
| [161] | Running reverse | |
| [165] | Local ref active | |
| [166] | Remote ref active | |
| [167] | Start command activ | |
| [168] | Drive in hand mode | |
| [169] | Drive in auto mode | |
| [193] | Sleep Mode | |
| [194] | Broken Belt Function | |

| 5-41 On Delay, Relay | | |
|----------------------|-------------|--|
| Range: | Function: | |
| 0.01 s* | [0 - 600 s] | |

| 5-42 Off Delay, Relay | | |
|-----------------------|-------------|--|
| Range: | Function: | |
| 0.01 s* | [0 - 600 s] | |

3.6.5 5-5* Pulse Input

The pulse input parameters are used to define an appropriate window for the impulse reference area by configuring the scaling and filter settings for the pulse inputs. Input terminals 29 or 33 act as frequency reference inputs. Set terminal 29 (5-13 Terminal 29 Digital Input) or terminal 33 (5-15 Terminal 33 Digital Input) to [32] Pulse input. If terminal 29 is used as an input, then set 5-01 Terminal 27 Mode to [0] Input.

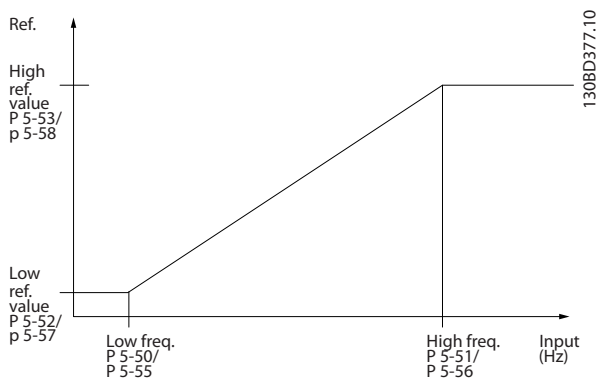

Illustration 3.12 Pulse Input

| 5-50 Term. 29 Low Frequency | | |
|-----------------------------|---|--|
| Range: | Function: | |
| 4 Hz* [4 - 31999 Hz] | Enter the low frequency limit corresponding to the low motor shaft speed (i.e. low reference value) in 5-52 Term. 29 Low Ref./Feedb. Value. Refer to the diagram in this section. | |

| 5-51 Term. 29 High Frequency | | |
|------------------------------|---|--|
| Range: | Function: | |
| 32000 Hz* [5 - 32000 Hz] | Enter the high frequency limit corresponding to the high motor shaft speed (i.e. high reference value) in 5-53 Term. 29 High Ref./Feedb. Value. | |

| 5-52 Term. 29 Low Ref./Feedb. Value | | |
|-------------------------------------|--|--|
| Range: | Function: | |
| 0 * [-4999 - 4999] | Enter the low reference value limit for the motor shaft speed [RPM]. This is also the lowest feedback value, see also 5-57 Term. 33 Low Ref./Feedb. Value. Set terminal 29 to digital input (5-02 Terminal 29 Mode = [0] input and 5-13 Terminal 29 Digital Input=applicable value). | |

| 5-53 Term. 29 High Ref./Feedb. Value | | |
|--------------------------------------|---|--|
| Range: | Function: | |
| Size related* [-4999 - 4999] | Enter the high reference value [RPM] for the motor shaft speed and the high feedback value, see also 5-58 Term. 33 High Ref./Feedb. Value. Select terminal 29 as a digital input (5-02 Terminal 29 Mode = [0] input (default) and 5-13 Terminal 29 Digital Input = applicable value). | |

| 5-55 Term. 33 Low Frequency | | |
|-----------------------------|---|--|
| Range: | Function: | |
| 4 Hz* [4 - 31999 Hz] | Enter the low frequency corresponding to the low motor shaft speed (i.e. low reference value) in 5-57 Term. 33 Low Ref./Feedb. Value. | |

| 5-56 Term. 33 High Frequency | | |
|------------------------------|---|--|
| Range: | Function: | |
| 32000 Hz* [5 - 32000 Hz] | Enter the high frequency corresponding to the high motor shaft speed (i.e. high reference value) in 5-58 Term. 33 High Ref./Feedb. Value. | |

| 5-57 Term. 33 Low Ref./Feedb. Value | | |
|-------------------------------------|---|--|
| Range: | Function: | |
| 0 * [-4999 - 4999] | Enter the low reference value [RPM] for the motor shaft speed. This is also the low feedback value, see also 5-52 Term. 29 Low Ref./Feedb. Value. | |

| 5-58 Term. 33 High Ref./Feedb. Value | | |
|--------------------------------------|--|--|
| Range: | Function: | |
| Size related* [-4999 - 4999] | Enter the high reference value [RPM] for the motor shaft speed. See also 5-53 Term. 29 High Ref./Feedb. Value. | |

3.6.6 5-6* Pulse Outputs

NOTE

These parameters cannot be adjusted while the motor is running.

These parameters are to configure pulse outputs with their functions and scaling. Terminal 27 and 29 are allocated to pulse output via 5-01 Terminal 27 Mode and 5-02 Terminal 29 Mode, respectively.

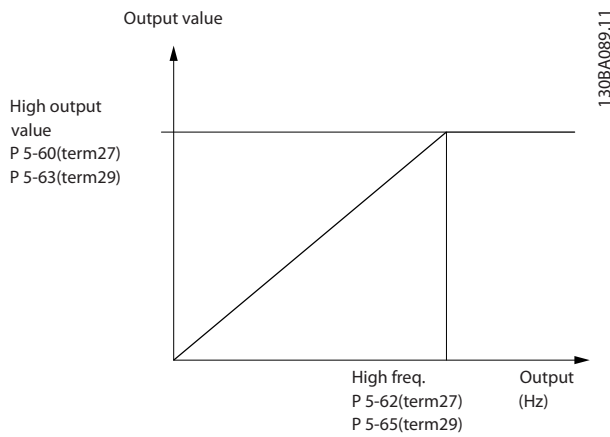

Illustration 3.13 Configuration of Pulse Outputs

| 5-60 Terminal 27 Pulse Output Variable | | |
|--|----------------------|--|
| Option: | Function: | |
| [0] | No operation | |
| [45] | Bus ctrl. | |
| [48] | Bus ctrl., timeout | |
| [100] | Output frequency | |
| [101] | Reference | |
| [102] | Process Feedback | |
| [103] | Motor Current | |
| [104] | Torque rel to limit | |
| [105] | Torq relate to rated | |
| [106] | Power | |
| [107] | Speed | |
| [109] | Max Out Freq | |

| 5-62 Pulse Output Max Freq 27 | | |
|-------------------------------|----------------|---|
| Range: | Function: | |
| 5000 Hz* | [4 - 32000 Hz] | Set the maximum frequency for terminal 27, corresponding to the output variable selected in 5-60 Terminal 27 Pulse Output Variable. |

| 5-63 Terminal 29 Pulse Output Variable | | |
|--|----------------------|--|
| Option: | Function: | |
| [0] | No operation | |
| [45] | Bus ctrl. | |
| [48] | Bus ctrl., timeout | |
| [100] | Output frequency | |
| [101] | Reference | |
| [102] | Process Feedback | |
| [103] | Motor Current | |
| [104] | Torque rel to limit | |
| [105] | Torq relate to rated | |
| [106] | Power | |
| [107] | Speed | |
| [109] | Max Out Freq | |

| 5-65 Pulse Output Max Freq 29 | | |
|-------------------------------|----------------|---|
| Range: | Function: | |
| 5000 Hz* | [4 - 32000 Hz] | Set the maximum frequency for terminal 29 corresponding to the output variable set in 5-63 Terminal 29 Pulse Output Variable. |

3

3.6.7 5-7* 24 V Encoder Input

Connect the 24 V encoder to terminal 12 (24 V DC supply), terminal 32 (Channel A), terminal 33 (Channel B), and terminal 20 (GND). The digital inputs 32/33 are active for encoder inputs when [1] 24 V encoder is selected in 7-00 Speed PID Feedback Source. The encoder used is a dual channel (A and B) 24 V type. Max input frequency: 32 kHz.

Encoder Connection to the frequency converter

24 V incremental encoder. Max. cable length 5 m.

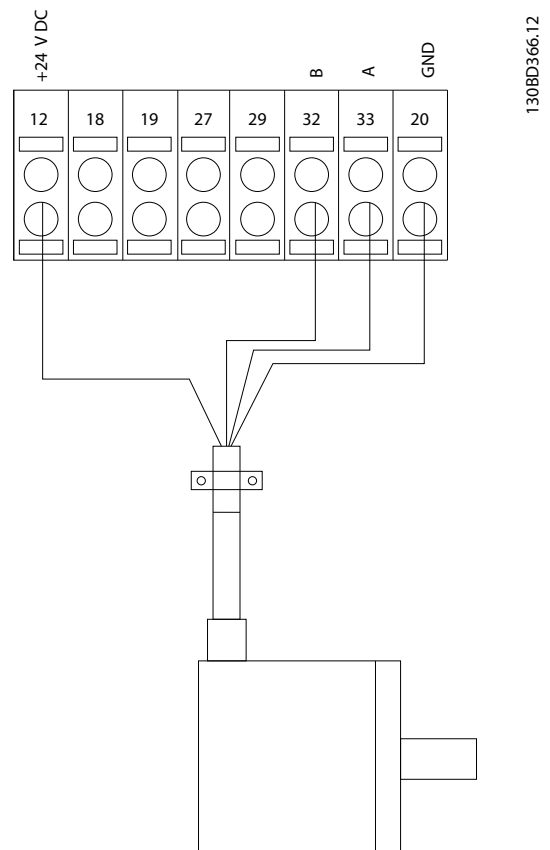

Illustration 3.14 24 V or 10-30 V Encoder Connection

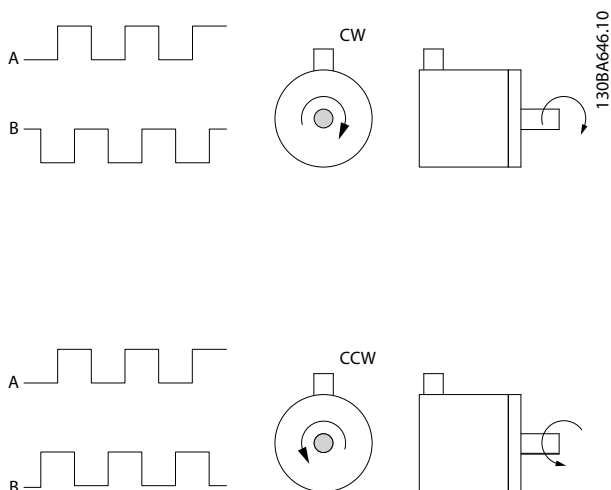

Illustration 3.15 Encoder Rotation Direction

| 5-70 Term 32/33 Pulses Per Revolution | | |
|---------------------------------------|-------------|--|
| Range: | Function: | |
| 1024 * | [1 - 4096] | Set the encoder pulses per revolution on the motor shaft. Read the correct value from the encoder. |

| 5-71 Term 32/33 Encoder Direction | | |
|-----------------------------------|-------------------|---|
| Option: | Function: | |
| | | <p>NOTE This parameter cannot be changed while the motor is running.</p> <p>Change the detected encoder rotation direction without changing the wiring to the encoder.</p> |
| [0] | Clockwise | Sets channel A 90° (electrical degrees) behind channel B upon clockwise rotation of the encoder shaft. |
| [1] | Counter clockwise | Sets channel A 90° (electrical degrees) ahead of channel B upon clockwise rotation of the encoder shaft. |

3.6.8 5-9* Bus Controlled

This parameter group selects digital and relay outputs via a fieldbus setting.

| 5-90 Digital & Relay Bus Control | | |
|----------------------------------|-------------------|---|
| Range: | Function: | |
| 0 * | [0 - 0xFFFFFFFF] | <p>This parameter holds the state of the digital outputs and relays that is controlled by bus.</p> <p>A logical '1' indicates that the output is high or active.</p> <p>A logical '0' indicates that the output is low or inactive.</p> |

| | |
|-------------|----------------------------|
| Bit 0 - 3 | Reserved |
| Bit 4 | Relay 1 output terminal |
| Bit 5 | Relay 2 output terminal |
| Bit 6 - 23 | Reserved |
| Bit 24 | Terminal 42 Digital Output |
| Bit 25 | Terminal 45 Digital Output |
| Bit 26 - 31 | Reserved |

Table 3.5 Bit Functions

| 5-93 Pulse Out 27 Bus Control | | |
|-------------------------------|-------------|--|
| Range: | Function: | |
| 0 %* | [0 - 100 %] | Set the output frequency transferred to the output terminal 27 when the terminal is configured as [45] Bus Controlled in 5-60 Terminal 27 Pulse Output Variable. |

| 5-94 Pulse Out 27 Timeout Preset | | |
|----------------------------------|-------------|---|
| Range: | Function: | |
| 0 %* | [0 - 100 %] | Set the output frequency transferred to the output terminal 27 when the terminal is configured as [48] Bus Ctrl Timeout in 5-60 Terminal 27 Pulse Output Variable and a time-out is detected. |

| 5-95 Pulse Out 29 Bus Control | | |
|-------------------------------|-------------|--|
| Range: | Function: | |
| 0 %* | [0 - 100 %] | Set the output frequency transferred to the output terminal 29 when the terminal is configured as [45] Bus Controlled in 5-63 Terminal 29 Pulse Output Variable. |

| 5-96 Pulse Out 29 Timeout Preset | | |
|----------------------------------|-------------|--|
| Range: | Function: | |
| 0 %* | [0 - 100 %] | Set the output frequency transferred to the output terminal 29 when the terminal is configured as [48] Bus Ctrl Timeout in 5-63 Terminal 29 Pulse Output Variable. And a time-out is detected. |

3.7 Parameters: 6-** Analog In/Out

Parameter group for setting up the analog I/O configuration and the digital output. The frequency converter is equipped with 2 analog inputs: Terminal 53 and 54. The analog inputs can freely be allocated to either voltage (0-10 V) or current input (0/4-20 mA)

3.7.1 6-0* Analog I/O Mode

| 6-00 Live Zero Timeout Time | | |
|-----------------------------|------------|--------------------------|
| Range: | Function: | |
| 10 s* | [1 - 99 s] | Enter the time-out time. |

| 6-01 Live Zero Timeout Function | | |
|---------------------------------|--|--|
| Option: | Function: | |
| | Select the time-out function. The function set in 6-01 Live Zero Timeout Function will be activated if the input signal on terminal 53 or 54 is below 50% of the value in 6-10 Terminal 53 Low Voltage, 6-12 Terminal 53 Low Current, 6-20 Terminal 54 Low Voltage or 6-22 Terminal 54 Low Current for a time period defined in 6-00 Live Zero Timeout Time. | |
| [0] | Off | |
| [1] | Freeze output | |
| [2] | Stop | |
| [3] | Jogging | |
| [4] | Max. speed | |
| [5] | Stop and trip | |

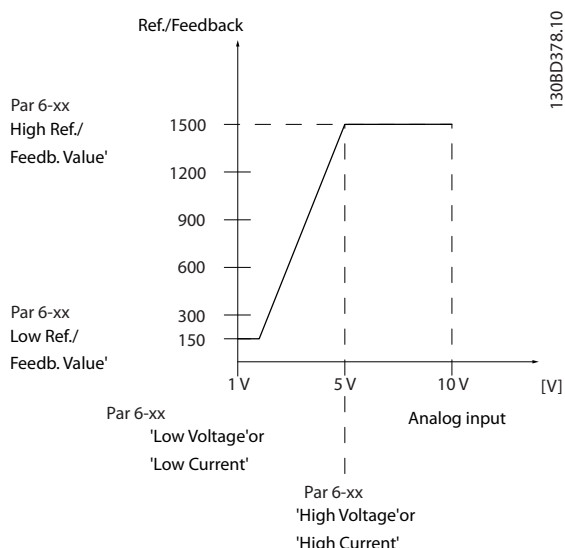

Illustration 3.16 Time-out Function

3.7.2 6-1* Analog Input 53

Parameters for configuring the scaling and limits for analog input 53 (terminal 53).

| 6-10 Terminal 53 Low Voltage | | |
|------------------------------|------------|---|
| Range: | Function: | |
| 0.07 V* | [0 - 10 V] | Enter the voltage (V) that corresponds to 6-14 Terminal 53 Low Ref./Feedb. Value. The value must be set at >1 V in order to activate 6-01 Live Zero Timeout Function. |

| 6-11 Terminal 53 High Voltage | | |
|-------------------------------|------------|--|
| Range: | Function: | |
| 10 V* | [0 - 10 V] | Enter the voltage (V) that corresponds to the high reference value (set in 6-15 Terminal 53 High Ref./Feedb. Value). |

| 6-12 Terminal 53 Low Current | | |
|------------------------------|-------------|--|
| Range: | Function: | |
| 4 mA* | [0 - 20 mA] | Enter the low current value. This reference signal should correspond to the low reference/feedback value, set in 6-14 Terminal 53 Low Ref./Feedb. Value. The value must be set at >2 mA in order to activate the Live Zero Time-out Function in 6-01 Live Zero Timeout Function. |

| 6-13 Terminal 53 High Current | | |
|-------------------------------|-------------|---|
| Range: | Function: | |
| 20 mA* | [0 - 20 mA] | Enter the high current value corresponding to the high reference/feedback set in 6-15 Terminal 53 High Ref./Feedb. Value. |

| 6-14 Terminal 53 Low Ref./Feedb. Value | | |
|--|----------------|--|
| Range: | Function: | |
| 0 * | [-4999 - 4999] | Enter the reference or feedback value that corresponds to the voltage or current set in parameters 6-10 to 6-12. |

| 6-15 Terminal 53 High Ref./Feedb. Value | | |
|---|----------------|--|
| Range: | Function: | |
| Size related* | [-4999 - 4999] | Enter the reference or feedback value that corresponds to the voltage or current set in parameters 6-11 to 6-13. |

| 6-16 Terminal 53 Filter Time Constant | | |
|---------------------------------------|---------------|---|
| Range: | Function: | |
| 0.01 s* | [0.01 - 10 s] | Enter the time constant. This is a first-order digital low pass filter time constant for suppressing electrical noise in terminal 53. A high time constant value improves |

| 6-16 Terminal 53 Filter Time Constant | | |
|---------------------------------------|---|--|
| Range: | Function: | |
| | dampening but also increases the time delay through the filter. | |

| 6-19 Terminal 53 mode | | |
|-----------------------|--|--|
| Option: | Function: | |
| | Select if terminal 54 is used for current- or voltage input. | |
| [0] | Current mode | |
| [1] | Voltage mode | |

3.7.3 6-2* Analog Input 54

Parameters for configuring the scaling and limits for analog input 54 (terminal 54).

| 6-20 Terminal 54 Low Voltage | | |
|------------------------------|------------|--|
| Range: | Function: | |
| 0.07 V* | [0 - 10 V] | Enter the voltage (V) that corresponds to the low reference value (set in <i>6-24 Terminal 54 Low Ref./Feedb. Value</i>). The value must be set at >1 V in order to activate <i>6-01 Live Zero Timeout Function</i> . |

| 6-21 Terminal 54 High Voltage | | |
|-------------------------------|------------|--|
| Range: | Function: | |
| 10 V* | [0 - 10 V] | Enter the voltage (V) that corresponds to the high reference value (set in <i>6-25 Terminal 54 High Ref./Feedb. Value</i>). |

| 6-22 Terminal 54 Low Current | | |
|------------------------------|-------------|---|
| Range: | Function: | |
| 4 mA* | [0 - 20 mA] | Enter the low current value. This reference signal should correspond to the low reference/feedback value, set in <i>6-24 Terminal 54 Low Ref./Feedb. Value</i> . The value must be set at >2 mA in order to activate the Live Zero Timeout Function in <i>6-01 Live Zero Timeout Function</i> . |

| 6-23 Terminal 54 High Current | | |
|-------------------------------|----------------------|---|
| Range: | Function: | |
| 20 mA* | [0 - 20 mA] | Enter the high current value corresponding to the high reference/feedback value set in <i>6-25 Terminal 54 High Ref./Feedb. Value</i> . |
| 20.00 mA* | [par. 6-22-20.00 mA] | |

| 6-24 Terminal 54 Low Ref./Feedb. Value | | |
|--|-----------------|---|
| Range: | Function: | |
| 0 * | [-4999 - 4999] | Enter the reference or feedback value that corresponds to the voltage or current set in |

| 6-24 Terminal 54 Low Ref./Feedb. Value | | |
|--|---|--|
| Range: | Function: | |
| | <i>6-21 Terminal 54 High Voltage/6-22 Terminal 54 Low Current</i> . | |

| 6-25 Terminal 54 High Ref./Feedb. Value | | |
|---|-----------------|--|
| Range: | Function: | |
| Size related* | [-4999 - 4999] | Enter the reference or feedback value that corresponds to the voltage or current set in <i>6-21 Terminal 54 High Voltage/6-23 Terminal 54 High Current</i> . |

| 6-26 Terminal 54 Filter Time Constant | | |
|---------------------------------------|---------------|---|
| Range: | Function: | |
| 0.01 s* | [0.01 - 10 s] | Enter the time constant. This is a first-order digital low pass filter time constant for suppressing electrical noise in terminal 54. A high time constant value improves dampening but also increases the time delay through the filter. |

| 6-29 Terminal 54 mode | | |
|-----------------------|--|--|
| Option: | Function: | |
| | Select if terminal 54 is used for current- or voltage input. | |
| [0] | Current mode | |
| [1] | Voltage mode | |

3.7.4 6-7* Analog/Digital Output 45

Parameters for configuring the scaling and limits for analog/digital output Terminal 45. Analog outputs are current outputs: 0/4-20 mA. Resolution on analog output is 12 bit. Analog output terminals can also be setup as digital output.

| 6-70 Terminal 45 Mode | | |
|-----------------------|---|--|
| Option: | Function: | |
| | Set terminal 45 to act as analog output or as digital output. | |
| [0] | 0-20 mA | |
| [1] | 4-20 mA | |
| [2] | Digital Output | |

| 6-71 Terminal 45 Analog Output | | |
|--------------------------------|---------------------|--|
| Option: | Function: | |
| [0] | No operation | |
| [100] | Output frequency | 0-100 Hz |
| [101] | Reference | Min _{Ref} -Max _{Ref} |
| [102] | Process Feedback | Min _{FB} -Max _{FB} |
| [103] | Motor Current | 0-I _{max} |
| [104] | Torque rel to limit | |

| 6-71 Terminal 45 Analog Output | | |
|--------------------------------|----------------------|--------------------|
| Option: | Function: | |
| [105] | Torq relate to rated | |
| [106] | Power | 0-P _{nom} |
| [107] | Speed | |
| [111] | Speed Feedback | |
| [139] | Bus Control | 0-100% |

| 6-72 Terminal 45 Digital Output | | |
|---------------------------------|--------------------------------|---|
| Option: | Function: | |
| | | Select the function of terminal 45 as a digital current output. See also <i>6-70 Terminal 45 Mode</i> . See <i>5-40 Function Relay</i> for descriptions of the choices. |
| [0] | No operation | |
| [1] | Control Ready | |
| [2] | Drive ready | |
| [3] | Drive rdy/rem ctrl | |
| [4] | Stand-by / no warning | |
| [5] | Running | |
| [6] | Running / no warning | |
| [7] | Run in range/no warn | |
| [8] | Run on ref/no warn | |
| [9] | Alarm | |
| [10] | Alarm or warning | |
| [11] | At torque limit | |
| [12] | Out of current range | |
| [13] | Below current, low | |
| [14] | Above current, high | |
| [15] | Out of frequency range | |
| [16] | Below frequency, low | |
| [17] | Above frequency, high | |
| [18] | Out of feedb. range | |
| [19] | Below feedback, low | |
| [20] | Above feedback, high | |
| [21] | Thermal warning | |
| [22] | Ready, no thermal warning | |
| [23] | Remote,ready,no TW | |
| [24] | Ready, no over-/ under voltage | |
| [25] | Reverse | |
| [26] | Bus OK | |
| [27] | Torque limit & stop | |
| [28] | Brake, no brake warning | |
| [29] | Brake ready, no fault | |
| [30] | Brake fault (IGBT) | |
| [31] | Relay 123 | |
| [32] | Mech brake ctrl | |
| [36] | Control word bit 11 | |
| [37] | Control word bit 12 | |
| [40] | Out of ref range | |
| [41] | Below reference, low | |

| 6-72 Terminal 45 Digital Output | | |
|---------------------------------|----------------------------------|--|
| Option: | Function: | |
| [42] | Above ref, high | |
| [45] | Bus ctrl. | |
| [46] | Bus control, timeout: On | |
| [47] | Bus control, timeout: Off | |
| [56] | Heat sink cleaning warning, high | |
| [60] | Comparator 0 | |
| [61] | Comparator 1 | |
| [62] | Comparator 2 | |
| [63] | Comparator 3 | |
| [64] | Comparator 4 | |
| [65] | Comparator 5 | |
| [70] | Logic rule 0 | |
| [71] | Logic rule 1 | |
| [72] | Logic rule 2 | |
| [73] | Logic rule 3 | |
| [74] | Logic rule 4 | |
| [75] | Logic rule 5 | |
| [80] | SL digital output A | |
| [81] | SL digital output B | |
| [82] | SL digital output C | |
| [83] | SL digital output D | |
| [160] | No alarm | |
| [161] | Running reverse | |
| [165] | Local ref active | |
| [166] | Remote ref active | |
| [167] | Start command activ | |
| [168] | Drive in hand mode | |
| [169] | Drive in auto mode | |
| [193] | Sleep Mode | |
| [194] | Broken Belt Function | |

| 6-73 Terminal 45 Output Min Scale | | |
|-----------------------------------|-------------|---|
| Range: | Function: | |
| 0 %* | [0 - 200 %] | Scale for the minimum output (0 or 4 mA) of the analogu signal at terminal 45. Set the value to be the percentage of the full range of the variable selected in <i>6-71 Terminal 45 Analog Output</i> . |

| 6-74 Terminal 45 Output Max Scale | | |
|-----------------------------------|-------------|--|
| Range: | Function: | |
| 100 %* | [0 - 200 %] | Scale for the maximum output (20 mA) of the analog signal at terminal 45. Set the value to be the percentage of the full range of the variable selected in <i>6-71 Terminal 45 Analog Output</i> . |

| 6-76 Terminal 45 Output Bus Control | | |
|-------------------------------------|--------------|--|
| Range: | Function: | |
| 0 * | [0 - 16384] | |

3.7.5 6-9* Analog/Digital Output 42

Parameters for configuring the limits for analog/digital output Terminal 42. Analog outputs are current outputs: 0/4-20 mA. Resolution on analog outputs is 12 bit. Analog output terminals can also be setup as digital output.

| 6-90 Terminal 42 Mode | | |
|-----------------------|----------------|---|
| Option: | Function: | |
| | | Set Terminal 42 to act as analog output or as digital output. |
| [0] | 0-20 mA | |
| [1] | 4-20 mA | |
| [2] | Digital Output | |

| 6-91 Terminal 42 Analog Output | | |
|--------------------------------|----------------------|--|
| Option: | Function: | |
| [0] | No operation | |
| [100] | Output frequency | |
| [101] | Reference | |
| [102] | Process Feedback | |
| [103] | Motor Current | |
| [104] | Torque rel to limit | |
| [105] | Torq relate to rated | |
| [106] | Power | |
| [107] | Speed | |
| [111] | Speed Feedback | |
| [139] | Bus Control | |

| 6-92 Terminal 42 Digital Output | | |
|---------------------------------|---------------------------|--|
| Option: | Function: | |
| [0] | No operation | |
| [1] | Control Ready | |
| [2] | Drive ready | |
| [3] | Drive rdy/rem ctrl | |
| [4] | Stand-by / no warning | |
| [5] | Running | |
| [6] | Running / no warning | |
| [7] | Run in range/no warn | |
| [8] | Run on ref/no warn | |
| [9] | Alarm | |
| [10] | Alarm or warning | |
| [11] | At torque limit | |
| [12] | Out of current range | |
| [13] | Below current, low | |
| [14] | Above current, high | |
| [15] | Out of frequency range | |
| [16] | Below frequency, low | |
| [17] | Above frequency, high | |
| [18] | Out of feedb. range | |
| [19] | Below feedback, low | |
| [20] | Above feedback, high | |
| [21] | Thermal warning | |
| [22] | Ready, no thermal warning | |
| [23] | Remote,ready,no TW | |

| 6-92 Terminal 42 Digital Output | | |
|---------------------------------|----------------------------------|--|
| Option: | Function: | |
| [24] | Ready, no over-/ under voltage | |
| [25] | Reverse | |
| [26] | Bus OK | |
| [27] | Torque limit & stop | |
| [28] | Brake, no brake warning | |
| [29] | Brake ready, no fault | |
| [30] | Brake fault (IGBT) | |
| [31] | Relay 123 | |
| [32] | Mech brake ctrl | |
| [36] | Control word bit 11 | |
| [37] | Control word bit 12 | |
| [40] | Out of ref range | |
| [41] | Below reference, low | |
| [42] | Above ref, high | |
| [45] | Bus ctrl. | |
| [46] | Bus control, timeout: On | |
| [47] | Bus control, timeout: Off | |
| [56] | Heat sink cleaning warning, high | |
| [60] | Comparator 0 | |
| [61] | Comparator 1 | |
| [62] | Comparator 2 | |
| [63] | Comparator 3 | |
| [64] | Comparator 4 | |
| [65] | Comparator 5 | |
| [70] | Logic rule 0 | |
| [71] | Logic rule 1 | |
| [72] | Logic rule 2 | |
| [73] | Logic rule 3 | |
| [74] | Logic rule 4 | |
| [75] | Logic rule 5 | |
| [80] | SL digital output A | |
| [81] | SL digital output B | |
| [82] | SL digital output C | |
| [83] | SL digital output D | |
| [160] | No alarm | |
| [161] | Running reverse | |
| [165] | Local ref active | |
| [166] | Remote ref active | |
| [167] | Start command activ | |
| [168] | Drive in hand mode | |
| [169] | Drive in auto mode | |
| [193] | Sleep Mode | |
| [194] | Broken Belt Function | |

| 6-93 Terminal 42 Output Min Scale | | |
|-----------------------------------|----------------|--|
| Range: | Function: | |
| 0 %* % | [0 - 200 %] | Scale for the minimum output (0 or 4 mA) of the analog signal at terminal 42. Set the value to be the percentage of the full range of the variable selected in 6-91 Terminal 42 Analog Output. |

| 6-94 Terminal 42 Output Max Scale | | |
|-----------------------------------|-------------|--|
| Range: | Function: | |
| 100 %* | [0 - 200 %] | Scale for maximum output (20 mA) of the scaling at terminal 42. Set the value to be the percentage of the full range of the variable selected in 6-91 Terminal 42 Analog Output. |
| | | |
| <p>Illustration 3.17</p> | | |

| 6-96 Terminal 42 Output Bus Control | | |
|-------------------------------------|--------------|--|
| Range: | Function: | |
| 0 * | [0 - 16384] | |

| 6-98 Drive Type | | |
|-----------------|-----------|--|
| Range: | Function: | |
| 0 * | [0 - 0] | |

3.8 Parameters: 7-** Controllers

3.8.1 7-0* Speed PID Ctrl.

3

| 7-00 Speed PID Feedback Source | | |
|--------------------------------|--------------------|---|
| Option: | Function: | |
| | | NOTE This parameter cannot be changed while the motor is running. Select feedback source for Speed CL Control. |
| [1] | 24V encoder | |
| [2] | MCB 102 | |
| [3] | MCB 103 | |
| [6] | Analog Input 53 | |
| [7] | Analog Input 54 | |
| [8] | Frequency input 29 | |
| [9] | Frequency input 33 | |
| [20] | None | |

| 7-02 Speed PID Proportional Gain | | |
|----------------------------------|---|--|
| Range: | Function: | |
| 0.015 * [0 - 1] | Enter the speed controller proportional gain. The proportional gain amplifies the error (i.e. the deviation between the feedback signal and the set-point). This parameter is used with <i>1-00 Configuration Mode [0] Speed open loop</i> and <i>[1] Speed closed loop</i> control. Quick control is obtained at high amplification. However if the amplification is too great, the process may become unstable. | |

| 7-03 Speed PID Integral Time | | |
|------------------------------|--|--|
| Range: | Function: | |
| 8 ms* [2 - 20000 ms] | Enter the speed controller integral time, which determines the time the internal PID control takes to correct errors. The greater the error, the more quickly the gain increases. The integral time causes a delay of the signal and therefore a dampening effect, and can be used to eliminate steady state speed error. Obtain quick control through a short integral time, though if the integral time is too short, the process becomes unstable. An excessively long integral time disables the integral action, leading to major deviations from the required reference, since the process regulator takes too long to regulate errors. This parameter is used with <i>[0] Speed open loop</i> and <i>[1] Speed closed loop</i> control, set in <i>1-00 Configuration Mode</i> . | |

| 7-04 Speed PID Differentiation Time | | |
|-------------------------------------|--|--|
| Range: | Function: | |
| 30 ms* [0 - 200 ms] | Enter the speed controller differentiation time. The differentiator does not react to constant error. It provides gain proportional to the rate of change of the speed feedback. The quicker the error changes, the stronger the gain from the differentiator. The gain is proportional with the speed at which errors change. Setting this parameter to zero disables the differentiator. This parameter is used with <i>1-00 Configuration Mode [1] Speed closed loop</i> control. | |

| 7-05 Speed PID Diff. Gain Limit | | |
|---------------------------------|--|--|
| Range: | Function: | |
| 5 * [1 - 20] | Set a limit for the gain provided by the differentiator. Since the differential gain increases at higher frequencies, limiting the gain may be useful. For example, set up a pure D-link at low frequencies and a constant D-link at higher frequencies. This parameter is used with <i>1-00 Configuration Mode [1] Speed closed loop</i> control. | |

| 7-06 Speed PID Lowpass Filter Time | | |
|------------------------------------|--|------------------------------------|
| Range: | Function: | |
| 10 ms* [1 - 100 ms] | NOTE Severe filtering can be detrimental to dynamic performance. This parameter is used with <i>1-00 Configuration Mode [1] Speed closed loop</i> . Set a time constant for the speed control low-pass filter. The low-pass filter improves steady-state performance and dampens oscillations on the feedback signal. This is an advantage if there is a great amount on noise in the system, see <i>Illustration 3.18</i> . For example, if a time constant (τ) of 100 ms is programmed, the cut-off frequency for the low-pass filter will be $1/0.1 = 10 \text{ RAD/s}$., corresponding to $(10/2 \times \pi) = 1.6 \text{ Hz}$. The PID regulator only regulates a feedback signal that varies by a frequency of less than 1.6 Hz. If the feedback signal varies by a higher frequency than 1.6 Hz, the PID regulator does not react. Practical settings of <i>7-06 Speed PID Lowpass Filter Time</i> taken from the number of pulses per revolutions from encoder: | |
| | Encoder PPR | 7-06 Speed PID Lowpass Filter Time |
| | 512 | 10 ms |
| | 1024 | 5 ms |
| | 2048 | 2 ms |
| | 4096 | 1 ms |

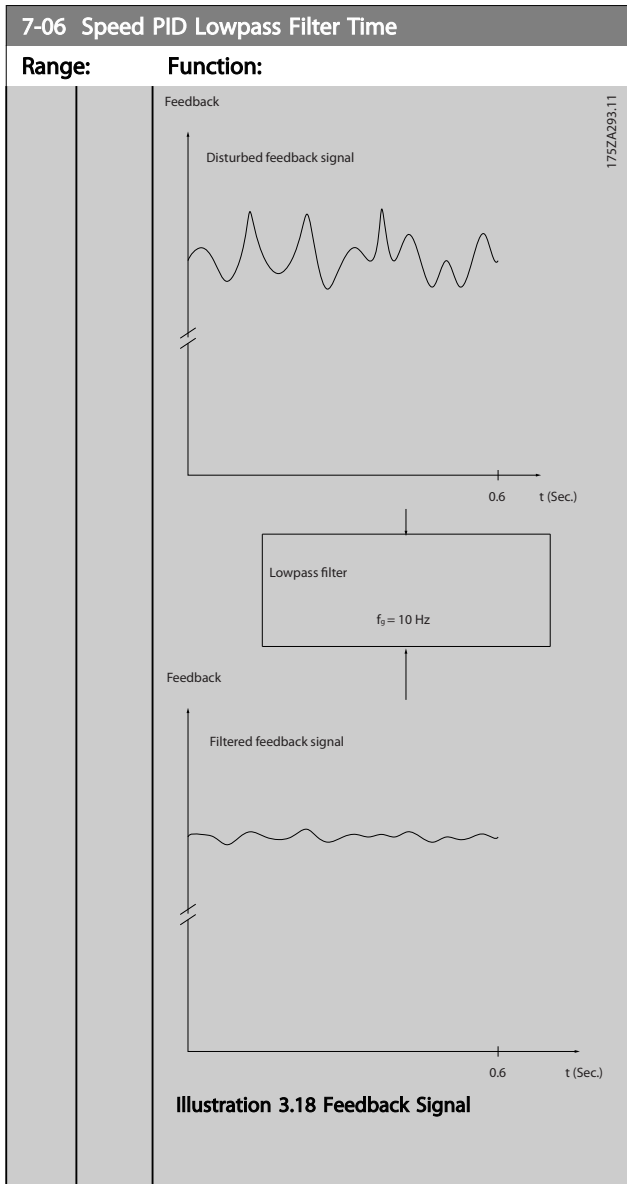

7-07 Speed PID Feedback Gear Ratio

| Range: | Function: |
|--------|----------------|
| 1 * | [0.0001 - 32] |

7-08 Speed PID Feed Forward Factor

| Range: | Function: |
|--------|---|
| 0 %* | [0 - 500 %] The reference signal bypasses the speed controller by the amount specified. This feature increases the dynamic performance of the speed control loop. |

3.8.2 7-1* Torque PI Control

Parameters for configuring the torque PI control in torque open loop (1-00 Configuration Mode).

7-12 Torque PID Proportional Gain

| Range: | Function: |
|--------|---|
| 100 %* | [0 - 500 %] Enter the proportional gain value for the torque controller. Selection of a high value makes the controller react faster. Too high a setting leads to controller instability. |

7-13 Torque PID Integration Time

| Range: | Function: |
|----------|---|
| 0.020 s* | [0.002 - 2 s] Enter the integration time for the torque controller. Selection as a low value make the controller react faster. Too low a setting leads to controller instability. |

3.8.3 7-2* Process Ctrl. Feedb.

Select the feedback sources for the Process PID Control, and how this feedback should be handled.

7-20 Process CL Feedback 1 Resource

| Option: | Function: |
|---------|--|
| | The effective feedback signal is made up of the sum of up to two different input signals. Select which input should be treated as the source of the first of these signals. The second input signal is defined in 7-22 Process CL Feedback 2 Resource. |
| [0] | No function |
| [1] | Analog Input 53 |
| [2] | Analog Input 54 |
| [3] | Frequency input 29 |
| [4] | Frequency input 33 |

7-22 Process CL Feedback 2 Resource

| Option: | Function: |
|---------|--|
| | The effective feedback signal is made up of the sum of up to two different input signals. Select which input should be treated as the source of the second of these signals. The first input signal is defined in 7-20 Process CL Feedback 1 Resource. |
| [0] | No function |
| [1] | Analog Input 53 |
| [2] | Analog Input 54 |
| [3] | Frequency input 29 |
| [4] | Frequency input 33 |

3

3.8.4 7-3* Process PID Ctrl.

| 7-30 Process PID Normal/ Inverse Control | | |
|--|-----------|--|
| Option: | Function: | |
| | | Normal and inverse control are implemented by introducing a difference between the reference signal and the feedback signal. |
| [0] | Normal | Sets process control to increase the output frequency. |
| [1] | Inverse | Sets process control to reduce the output frequency. |

| 7-31 Process PID Anti Windup | | |
|------------------------------|-----------|---|
| Option: | Function: | |
| [0] | Off | Continues regulation of an error even when the output frequency cannot be increased or decreased. |
| [1] | On | Ceases regulation of an error when the output frequency can no longer be adjusted. |

| 7-32 Process PID Start Speed | | |
|------------------------------|----------------|--|
| Range: | Function: | |
| 0 RPM* | [0 - 6000 RPM] | Enter the motor speed to be attained as a start signal for commencement of PID control. When the power is switched on, the frequency converter will commence ramping and then operate under speed open loop control. Thereafter, when the Process PID start speed is reached, the frequency converter will change over to Process PID control. |

| 7-33 Process PID Proportional Gain | | |
|------------------------------------|-----------|--|
| Range: | Function: | |
| 0.01 * | [0 - 10] | Enter the PID proportional gain. The proportional gain multiplies the error between the set point and the feedback signal. |

| 7-34 Process PID Integral Time | | |
|--------------------------------|-----------------|--|
| Range: | Function: | |
| 9999 s* | [0.10 - 9999 s] | Enter the PID integral time. The integrator provides an increasing gain at a constant error between the set point and the feedback signal. The integral time is the time needed by the integrator to reach the same gain as the proportional gain. |

| 7-35 Process PID Differentiation Time | | |
|---------------------------------------|------------|--|
| Range: | Function: | |
| 0 s* | [0 - 20 s] | Enter the PID differentiation time. The differentiator does not react to a constant error, but provides a gain only when the error changes. The shorter the PID differentiation time, the stronger the gain from the differentiator. |

| 7-36 Process PID Diff. Gain Limit | | |
|-----------------------------------|-----------|--|
| Range: | Function: | |
| 5 * | [1 - 50] | Enter a limit for the differentiator gain (DG). If there is no limit, the DG will increase when there are fast changes. Limit the DG to obtain a pure differentiator gain at slow changes and a constant differentiator gain where fast changes occur. |

| 7-38 Process PID Feed Forward Factor | | |
|--------------------------------------|-------------|---|
| Range: | Function: | |
| 0 %* | [0 - 200 %] | Enter the PID feed forward (FF) factor. The FF factor sends a constant fraction of the reference signal to bypass the PID control, so the PID control only affects the remaining fraction of the control signal. Any change to this parameter will thus affect the motor speed. When the FF factor is activated it provides less overshoot, and high dynamics when changing the set point. <i>7-38 Process PID Feed Forward Factor is active when 1-00 Configuration Mode is set to [3] Process.</i> |

| 7-39 On Reference Bandwidth | | |
|-----------------------------|-------------|---|
| Range: | Function: | |
| 5 %* | [0 - 200 %] | Enter the On Reference bandwidth. When the PID Control Error (the difference between the reference and the feedback) is less than the set value of this parameter the On Reference status bit is high, i.e. =1. |

3.8.5 7-4* Advanced Process PID Ctrl.

This parameter group is only used if *1-00 Configuration Mode* is set to *[7] Extended PID speed CL*.

| 7-40 Process PID I-part Reset | | |
|-------------------------------|-----------|---|
| Option: | Function: | |
| [0] | No | |
| [1] | Yes | Select <i>[1] Yes</i> to reset the I-part of the process PID controller. The selection will automatically revert to <i>[0] No</i> . Resetting the I-part makes it possible to start from a welldefined point after changing something in the process, e.g. changing a textile roll. |

| 7-41 Process PID Output Neg. Clamp | | |
|------------------------------------|----------------|---|
| Range: | Function: | |
| -100 %* | [-100 - 100 %] | Enter a negative limit for the process PID controller output. |

| 7-42 Process PID Output Pos. Clamp | | |
|------------------------------------|----------------|---|
| Range: | Function: | |
| 100 %* | [-100 - 100 %] | Enter a positive limit for the process PID controller output. |

| 7-43 Process PID Gain Scale at Min. Ref. | | |
|--|-------------|--|
| Range: | | Function: |
| 100 %* | [0 - 100 %] | Enter a scaling percentage to apply to the process PID output when operating at the minimum reference. The scaling percentage will be adjusted linearly between the scale at min. ref. (7-43 Process PID Gain Scale at Min. Ref.) and the scale at max. ref. (7-44 Process PID Gain Scale at Max. Ref.). |

| 7-44 Process PID Gain Scale at Max. Ref. | | |
|--|-------------|--|
| Range: | | Function: |
| 100 %* | [0 - 100 %] | Enter a scaling percentage to apply to the process PID output when operating at the maximum reference. The scaling percentage will be adjusted linearly between the scale at min. ref. (7-43 Process PID Gain Scale at Min. Ref.) and the scale at max. ref. (7-44 Process PID Gain Scale at Max. Ref.). |

| 7-45 Process PID Feed Fwd Resource | | |
|------------------------------------|---------------------|--|
| Option: | | Function: |
| | | Select which frequency converter input should be used as the feed forward factor. The FF factor is added directly to the output of the PID controller. This increases dynamic performance. |
| [0] | No function | |
| [1] | Analog Input 53 | |
| [2] | Analog Input 54 | |
| [7] | Frequency input 29 | |
| [8] | Frequency input 33 | |
| [11] | Local bus reference | |

| 7-46 Process PID Feed Fwd Normal/ Inv. Ctrl. | | |
|--|---------|--|
| Option: | | Function: |
| [0] | Normal | Select [0] Normal to set the feed forward factor to treat the FF resource as a positive value. |
| [1] | Inverse | Select [1] Inverse to treat the FF resource as a negative value. |

| 7-49 Process PID Output Normal/ Inv. Ctrl. | | |
|--|---------|--|
| Option: | | Function: |
| [0] | Normal | Select [0] Normal to use the resulting output from the process PID controller as is. |
| [1] | Inverse | Select [1] Inverse to invert the resulting output from the process PID controller. This operation is performed after the feed forward factor is applied. |

3.8.6 7-5* Ext. Process PID Ctrl.

This parameter group is only used if 1-00 Configuration Mode is set to [7] Extended PID speed CL.

| 7-50 Process PID Extended PID | | |
|-------------------------------|----------|--|
| Option: | | Function: |
| [0] | Disabled | Disables the extended parts of the process PID controller. |
| [1] | Enabled | Enables the extended parts of the PID controller. |

| 7-51 Process PID Feed Fwd Gain | | |
|--------------------------------|------------|---|
| Range: | | Function: |
| 1 * | [0 - 100] | The feed forward is used to obtain the desired level, based on a well-known signal available. The PID controller then only takes care of the smaller part of the control, necessary because of unknown characters. The standard feed fwd factor in 7-38 Process PID Feed Forward Factor is always related to the reference whereas 7-51 Process PID Feed Fwd Gain has more choices. In winder applications, the feed fwd factor will typically be the line speed of the system. |

| 7-52 Process PID Feed Fwd Ramp up | | |
|-----------------------------------|----------------|---|
| Range: | | Function: |
| 0.01 s* | [0.01 - 100 s] | Controls dynamics of the feed forward signal when ramping up. |

| 7-53 Process PID Feed Fwd Ramp down | | |
|-------------------------------------|----------------|---|
| Range: | | Function: |
| 0.01 s* | [0.01 - 100 s] | Controls the dynamics of the feed forward signal when ramping down. |

| 7-56 Process PID Ref. Filter Time | | |
|-----------------------------------|---------------|---|
| Range: | | Function: |
| 0.001 s* | [0.001 - 1 s] | Set a time constant for the reference first order low-pass filter. The low-pass filter improves steady-state performance and dampens oscillations on the reference/ feedback signals. However severe filtering can be detrimental to dynamic performance. |

| 7-57 Process PID Fb. Filter Time | | |
|----------------------------------|---------------|--|
| Range: | | Function: |
| 0.001 s* | [0.001 - 1 s] | Set a time constant for the feedback first order low-pass filter. The low-pass filter improves steady-state performance and dampens oscillations on the reference/ feedback signals. However severe filtering can be detrimental to dynamic performance. |

3

| 7-60 Feedback 1 Conversion | | |
|----------------------------|-------------|--|
| Option: | Function: | |
| [0] | Linear | |
| [1] | Square root | |

| 7-62 Feedback 2 Conversion | | |
|----------------------------|-------------|--|
| Option: | Function: | |
| [0] | Linear | |
| [1] | Square root | |

3.9 Parameters: 8-** Communications and Options

3.9.1 8-0* General Settings

| 8-01 Control Site | | |
|-------------------|-----------------------|--|
| Option: | Function: | |
| | | The setting in this parameter overrides the settings in 8-50 <i>Coasting Select</i> to 8-56 <i>Preset Reference Select</i> . |
| [0] | Digital and ctrl.word | Control by using both digital input and control word. |
| [1] | Digital only | Control by using digital inputs only. |
| [2] | Controlword only | Control by using control word only. |

| 8-02 Control Source | | |
|---------------------|-----------|--|
| Option: | Function: | |
| | | NOTE This parameter cannot be adjusted while the motor is running. |
| [0] | None | |
| [1] | FC Port | |

| 8-03 Control Timeout Time | | |
|---------------------------|----------------|--|
| Range: | Function: | |
| 1 s* | [0.1 - 6000 s] | Enter the maximum time expected to pass between the reception of two consecutive telegrams. If this time is exceeded, it indicates that the serial communication has stopped. The function is selected in 8-04 <i>Control Timeout Function</i> will then be carried out. |

| 8-04 Control Timeout Function | | |
|-------------------------------|-----------|---|
| Option: | Function: | |
| [0] | Off | Select the time-out function. The time-out function is activated when the control word fails to be updated within the time period specified in 8-03 <i>Control Timeout Time</i> . |

3.9.2 8-1* Ctrl. Word Settings

| 8-10 Control Word Profile | | |
|---------------------------|--------------------|---|
| Option: | Function: | |
| | | Select the interpretation of the control and status words corresponding to the installed fieldbus. Only the selections valid for the fieldbus installed in slot A will be visible in the LCP display. For guidelines in selection of [0] <i>FC profile</i> and [1] <i>PROFIdrive profile</i> , refer to the <i>Serial communication via RS-485 Interface</i> section in the Design Guide. For additional guidelines in the selection of [1] <i>PROFIdrive profile</i> , refer to the Operating Instructions for the installed fieldbus. |
| | | Option: Function: |
| [0] | FC profile | |
| [1] | PROFIdrive profile | |

3.9.3 8-3* FC Port Settings

| 8-30 Protocol | | |
|---------------|------------|---|
| Option: | Function: | |
| | | Select the protocol for the integrated RS-485 port. |
| [0] | FC | Communication according to the FC Protocol. |
| [2] | Modbus RTU | Communication according to the Modbus RTU protocol. |

| 8-31 Address | | |
|--------------|--------------|---|
| Range: | Function: | |
| 1 * | [0.0 - 247] | Enter the address for the RS-485 port. Valid range: 1-126 for FC-bus or 1-247 for Modbus. |

| 8-32 Baud Rate | | |
|----------------|-------------|---|
| Option: | Function: | |
| | | Select the baud rate for the RS-485 port. |
| [0] | 2400 Baud | |
| [1] | 4800 Baud | |
| [2] | 9600 Baud | |
| [3] | 19200 Baud | |
| [4] | 38400 Baud | |
| [5] | 57600 Baud | |
| [6] | 76800 Baud | |
| [7] | 115200 Baud | |

| 8-33 Parity / Stop Bits | | |
|-------------------------|-------------------------|--|
| Option: | Function: | |
| [0] | Even Parity, 1 Stop Bit | |
| [1] | Odd Parity, 1 Stop Bit | |
| [2] | No Parity, 1 Stop Bit | |
| [3] | No Parity, 2 Stop Bits | |

| 8-35 Minimum Response Delay | | |
|-----------------------------|-------------------|---|
| Range: | | Function: |
| 0.01 s* | [0.0010 - 0.5 s] | Specify the minimum delay time between receiving a request and transmitting a response. This is used for overcoming modem turn-around delays. |

| 8-36 Maximum Response Delay | | |
|-----------------------------|-----------------|---|
| Range: | | Function: |
| Size related* | [0.1 - 10.0 s] | Specify the maximum permissible delay time between receiving a request and transmitting the response. If this time is exceeded, no response will be returned. |

| 8-37 Maximum Inter-char delay | | |
|-------------------------------|-------------------|---|
| Range: | | Function: |
| 0.025 s* | [0.025 - 0.025 s] | Specify the maximum delay time between 2 characters in a message. Exceeding this delay time will cause the message to be discarded. |

3.9.4 8-4* FC MC Protocol Set

| 8-43 PCD Read Configuration | | |
|-----------------------------|-----------------------------------|--|
| Option: | Function: | |
| [0] | None | |
| [1] | [1500] Operation Hours | |
| [2] | [1501] Running Hours | |
| [3] | [1502] kWh Counter | |
| [4] | [1600] Control Word | |
| [5] | [1601] Reference [Unit] | |
| [6] | [1602] Reference % | |
| [7] | [1603] Status Word | |
| [8] | [1605] Main Actual Value [%] | |
| [9] | [1609] Custom Readout | |
| [10] | [1610] Power [kW] | |
| [11] | [1611] Power [hp] | |
| [12] | [1612] Motor Voltage | |
| [13] | [1613] Frequency | |
| [14] | [1614] Motor Current | |
| [15] | [1615] Frequency [%] | |
| [16] | [1618] Motor Thermal | |
| [17] | [1630] DC Link Voltage | |
| [18] | [1634] Heatsink Temp. | |
| [19] | [1635] Inverter Thermal | |
| [20] | [1638] SL Controller State | |
| [21] | [1650] External Reference | |
| [22] | [1652] Feedback [Unit] | |
| [23] | [1660] Digital Input 18,19,27,33 | |
| [24] | [1661] Terminal 53 Switch Setting | |
| [25] | [1662] Analog Input 53(V) | |

| 8-43 PCD Read Configuration | | |
|-----------------------------|-----------------------------------|--|
| Option: | Function: | |
| [26] | [1663] Terminal 54 Switch Setting | |
| [27] | [1664] Analog Input 54 | |
| [28] | [1665] Analog Output 42 [mA] | |
| [29] | [1671] Relay Output [bin] | |
| [30] | [1672] Counter A | |
| [31] | [1673] Counter B | |
| [32] | [1690] Alarm Word | |
| [33] | [1692] Warning Word | |
| [34] | [1694] Ext. Status Word | |

3.9.5 8-5* Digital/Bus

Parameters for configuring the control word Digital/Bus merging.

NOTE

These parameters are active only when 8-01 Control Site is set to [0] Digital and control word.

| 8-50 Coasting Select | | |
|----------------------|---------------|---|
| Option: | Function: | |
| | | Select control of the coasting function via the terminals (digital input) and/or via the bus. |
| [0] | Digital input | Activates Start command via a digital input. |
| [1] | Bus | Activates Start command via the serial communication port or fieldbus option. |
| [2] | Logic AND | Activates Start command via the fieldbus/serial communication port, AND additionally via one of the digital inputs. |
| [3] | Logic OR | Activates Start command via the fieldbus/serial communication port OR via one of the digital inputs. |

| 8-51 Quick Stop Select | | |
|---|---------------|--|
| Select control of the Quick Stop function via the terminals (digital input) and/or via the bus. | | |
| Option: | Function: | |
| [0] | Digital input | |
| [1] | Bus | |
| [2] | Logic AND | |
| [3] | Logic OR | |

| 8-52 DC Brake Select | | |
|----------------------|---------------|--|
| Option: | Function: | |
| | | Select control of the DC brake via the terminals (digital input) and/or via the fieldbus. NOTE Only selection [0] Digital input is available when 1-10 Motor Construction is set to [1] PM non-salient SPM. |
| [0] | Digital input | Activates Start command via a digital input. |

| 8-53 Start Select | | |
|-------------------|---------------|---|
| Option: | Function: | |
| | | Select control of the frequency converter start function via the terminals (digital input) and/or via the fieldbus. |
| [0] | Digital input | Activates Start command via a digital input. |
| [1] | Bus | Activates Start command via the serial communication port or fieldbus option. |
| [2] | Logic AND | Activates Start command via the fieldbus/serial communication port, AND additionally via one of the digital inputs. |
| [3] | Logic OR | Activates Start command via the fieldbus/serial communication port OR via one of the digital inputs. |

| 8-54 Reversing Select | | |
|-----------------------|---------------|---|
| Option: | Function: | |
| [0] | Digital input | Select control of the frequency converter reverse function via the terminals (digital input) and/or via the fieldbus. |
| [1] | Bus | Activates the Reverse command via the serial communication port or fieldbus option. |
| [2] | Logic AND | Activates the Reverse command via the fieldbus/serial communication port, AND additionally via one of the digital inputs. |
| [3] | Logic OR | Activates the Reverse command via the fieldbus/serial communication port OR via one of the digital inputs. |

| 8-55 Set-up Select | | |
|--------------------|---------------|---|
| Option: | Function: | |
| | | Select control of the frequency converter set-up selection via the terminals (digital input) and/or via the fieldbus. |
| [0] | Digital input | Activates the set-up selection via a digital input. |
| [1] | Bus | Activates the set-up selection via the serial communication port or fieldbus option. |

| 8-55 Set-up Select | | |
|--------------------|-----------|--|
| Option: | Function: | |
| [2] | Logic AND | Activates the set-up selection via the fieldbus/serial communication port, AND additionally via one of the digital inputs. |
| [3] | Logic OR | Activate the set-up selection via the fieldbus/serial communication port OR via one of the digital inputs. |

| 8-56 Preset Reference Select | | |
|------------------------------|---------------|--|
| Option: | Function: | |
| | | Select control of the frequency converter Preset Reference selection via the terminals (digital input) and/or via the fieldbus. |
| [0] | Digital input | Activates Preset Reference selection via a digital input. |
| [1] | Bus | Activates Preset Reference selection via the serial communication port or fieldbus option. |
| [2] | Logic AND | Activates Preset Reference selection via the fieldbus/serial communication port, AND additionally via one of the digital inputs. |
| [3] | Logic OR | Activates the Preset Reference selection via the fieldbus/serial communication port OR via one of the digital inputs. |

| 8-57 Profidrive OFF2 Select | | |
|---|---------------|--|
| Select control of the frequency converter OFF2 selection via the terminals (digital input) and/or via the fieldbus. This parameter is active only when 8-01 Control Site is set to [0] Digital and ctrl. word and 8-10 Control Word Profile is set to [1] Profidrive profile. | | |
| Option: | Function: | |
| [0] | Digital input | |
| [1] | Bus | |
| [2] | Logic AND | |
| [3] | Logic OR | |

| 8-58 Profidrive OFF3 Select | | |
|---|---------------|--|
| Select control of the frequency converter OFF3 selection via the terminals (digital input) and/or via the fieldbus. This parameter is active only when 8-01 Control Site is set to [0] Digital and ctrl. word and 8-10 Control Word Profile is set to [1] Profidrive profile. | | |
| Option: | Function: | |
| [0] | Digital input | |
| [1] | Bus | |
| [2] | Logic AND | |
| [3] | Logic OR | |

| 8-79 Protocol Firmware version | | |
|--------------------------------|--------------|--|
| Range: | Function: | |
| Size related* | [0 - 65535] | |

3.9.6 8-8* FC Port Diagnostics

These parameters are used for monitoring the Bus communication via the FC Port.

3

| 8-80 Bus Message Count | | |
|------------------------|--------------|---|
| Range: | Function: | |
| 0 * | [0 - 65536] | This parameter shows the number of valid telegrams detected on the bus. |

| 8-81 Bus Error Count | | |
|----------------------|--------------|--|
| Range: | Function: | |
| 0 * | [0 - 65536] | This parameter shows the number of telegrams with faults (e.g. CRC faults), detected on the bus. |

| 8-82 Slave Messages Rcvd | | |
|--------------------------|--------------|---|
| Range: | Function: | |
| 0 * | [0 - 65536] | This parameter shows the number of valid telegrams addressed to the slave, sent by the frequency converter. |

| 8-83 Slave Error Count | | |
|------------------------|--------------|---|
| Range: | Function: | |
| 0 * | [0 - 65536] | This parameter shows the number of error telegrams, which could not be executed by the frequency converter. |

| 8-84 Slave Messages Sent | | |
|--------------------------|--------------|--|
| Range: | Function: | |
| 0 * | [0 - 65536] | This parameter shows the number of messages sent from the slave. |

| 8-85 Slave Timeout Errors | | |
|---------------------------|--------------|---|
| Range: | Function: | |
| 0 * | [0 - 65536] | This parameter shows the number of slave time-out errors. |

| 8-88 Reset FC port Diagnostics | | |
|--------------------------------|---------------|--|
| Option: | Function: | |
| [0] | Do not reset | |
| [1] | Reset counter | |

3.10 Parameters: 13-** Smart Logic Control

3.10.1 Prog. Features

Smart Logic Control (SLC) is essentially a sequence of user defined actions (see 13-52 *SL Controller Action [x]*) executed by the SLC when the associated user defined event (see 13-51 *SL Controller Event [x]*) is evaluated as TRUE by the SLC.

The condition for an event can be a particular status or that the output from a Logic Rule or a Comparator Operand becomes TRUE. That will lead to an associated Action as illustrated:

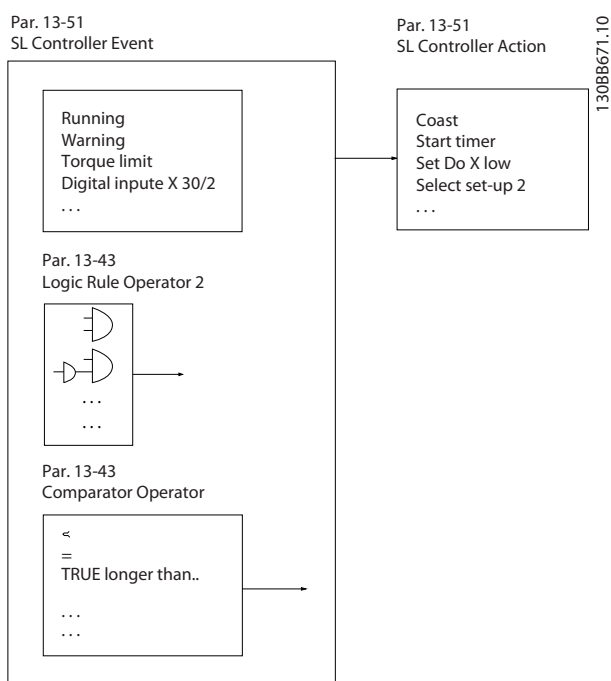

Illustration 3.19 Smart Logic Control (SLC)

Events and actions are each numbered and linked together in pairs (states). This means that when event [0] is fulfilled (attains the value TRUE), action [0] is executed. After this, the conditions of event [1] will be evaluated and if evaluated TRUE, action [1] will be executed and so on. Only one event will be evaluated at any time. If an event is evaluated as FALSE, nothing happens (in the SLC) during the current scan interval and no other events will be evaluated. This means that when the SLC starts, it evaluates event [0] (and only event [0]) each scan interval. Only when event [0] is evaluated TRUE, will the SLC execute action [0] and start evaluating event [1]. It is possible to programme from 1 to 20 events and actions. When the last event/action has been executed, the sequence starts over again from event [0]/action [0]. The illustration shows an example with three event/actions:

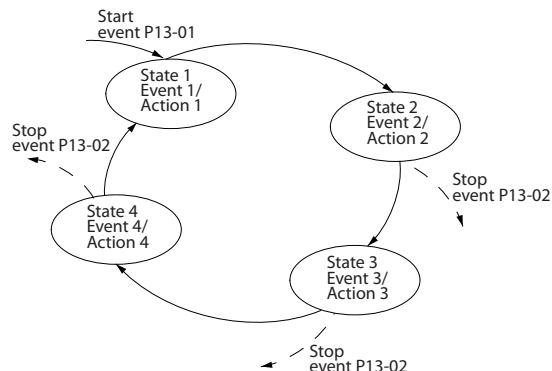

Illustration 3.20 Events and Actions

Starting and stopping the SLC:

Starting and stopping the SLC can be done by selecting .On [1]. or .Off [0]. in 13-00 *SL Controller Mode*. The SLC always starts in state 0 (where it evaluates event [0]). The SLC starts when the Start Event (defined in 13-01 *Start Event*) is evaluated as TRUE (provided that On [1] is selected in 13-00 *SL Controller Mode*). The SLC stops when the Stop Event (13-02 *Stop Event*) is TRUE. 13-03 *Reset SLC* resets all SLC parameters and start programming from scratch.

NOTE

SLC is only active in AUTO mode, not Hand On mode

3.10.2 13-0* SLC Settings

Use the SLC settings to activate, deactivate and reset the Smart Logic Control sequence. The logic functions and comtors are always running in the background, which opens for sete control of digital inputs and outputs.

| 13-00 SL Controller Mode | | |
|--------------------------|-----------|--------------------------------------|
| Option: | Function: | |
| [0] | Off | Disables the Smart Logic Controller. |
| [1] | On | Enables the Smart Logic Controller. |

| 13-01 Start Event | | |
|-------------------|----------------------|--|
| Option: | Function: | |
| [0] | False | |
| [1] | True | |
| [2] | Running | |
| [3] | In range | |
| [4] | On reference | |
| [7] | Out of current range | |
| [8] | Below I low | |
| [9] | Above I high | |
| [16] | Thermal warning | |
| [17] | Mains out of range | |

| 13-01 Start Event | |
|-------------------|--------------------|
| Option: | Function: |
| [18] | Reversing |
| [19] | Warning |
| [20] | Alarm (trip) |
| [21] | Alarm (trip lock) |
| [22] | Comparator 0 |
| [23] | Comparator 1 |
| [24] | Comparator 2 |
| [25] | Comparator 3 |
| [26] | Logic rule 0 |
| [27] | Logic rule 1 |
| [28] | Logic rule 2 |
| [29] | Logic rule 3 |
| [33] | Digital input DI18 |
| [34] | Digital input DI19 |
| [35] | Digital input DI27 |
| [36] | Digital input DI29 |
| [39] | Start command |
| [40] | Drive stopped |
| [42] | Auto Reset Trip |
| [50] | Comparator 4 |
| [51] | Comparator 5 |
| [60] | Logic rule 4 |
| [61] | Logic rule 5 |
| [83] | Broken Belt |

| 13-02 Stop Event | |
|------------------|----------------------|
| Option: | Function: |
| [0] | False |
| [1] | True |
| [2] | Running |
| [3] | In range |
| [4] | On reference |
| [7] | Out of current range |
| [8] | Below I low |
| [9] | Above I high |
| [16] | Thermal warning |
| [17] | Mains out of range |
| [18] | Reversing |
| [19] | Warning |
| [20] | Alarm (trip) |
| [21] | Alarm (trip lock) |
| [22] | Comparator 0 |
| [23] | Comparator 1 |
| [24] | Comparator 2 |
| [25] | Comparator 3 |
| [26] | Logic rule 0 |
| [27] | Logic rule 1 |
| [28] | Logic rule 2 |
| [29] | Logic rule 3 |
| [30] | SL Time-out 0 |
| [31] | SL Time-out 1 |
| [32] | SL Time-out 2 |

| 13-02 Stop Event | |
|------------------|--------------------|
| Option: | Function: |
| [33] | Digital input DI18 |
| [34] | Digital input DI19 |
| [35] | Digital input DI27 |
| [36] | Digital input DI29 |
| [39] | Start command |
| [40] | Drive stopped |
| [42] | Auto Reset Trip |
| [50] | Comparator 4 |
| [51] | Comparator 5 |
| [60] | Logic rule 4 |
| [61] | Logic rule 5 |
| [70] | SL Time-out 3 |
| [71] | SL Time-out 4 |
| [72] | SL Time-out 5 |
| [73] | SL Time-out 6 |
| [74] | SL Time-out 7 |
| [83] | Broken Belt |

| 13-03 Reset SLC | |
|-----------------|---|
| Option: | Function: |
| [0] | Do not reset SLC Retains programmed settings in all parameter group 13-** <i>Smart Logic Control</i> . |
| [1] | Reset SLC Resets all parameters in parameter group 13-** <i>Smart Logic Control</i> to default settings. |

3.10.3 13-1* Comparators

Comparators are used for comparing continuous variables (i.e. output frequency, output current, analog input etc.) to fixed preset values.

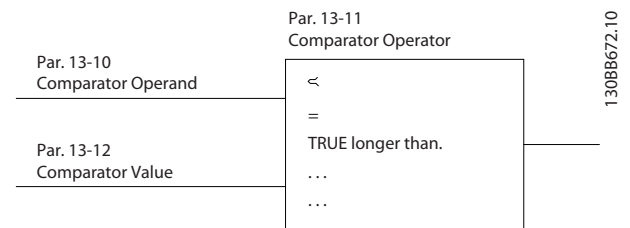

Illustration 3.21 Comparators

In addition, there are digital values that will be compared to fixed time values. See explanation in *13-10 Comparator Operand*. Comparators are evaluated once in each scan interval. Use the result (TRUE or FALSE) directly. All parameters in this parameter group are array parameters with index 0 to 5. Select index 0 to programme Comparator 0, select index 1 to programme Comparator 1, and so on.

| 13-10 Comparator Operand | | |
|--------------------------|-------------------|--|
| Option: | Function: | |
| [0] | Disabled | |
| [1] | Reference | |
| [2] | Feedback | |
| [3] | Motor speed | |
| [4] | Motor Current | |
| [6] | Motor power | |
| [7] | Motor voltage | |
| [12] | Analog input AI53 | |
| [13] | Analog input AI54 | |
| [18] | Pulse input FI29 | |
| [19] | Pulse input FI33 | |
| [20] | Alarm number | |
| [30] | Counter A | |
| [31] | Counter B | |

| 13-11 Comparator Operator | | |
|---------------------------|------------------|--|
| Option: | Function: | |
| | | Select the operator to be used in the comparison. This is an array parameter containing comparator operators 0 to 5. |
| [0] | Less Than (<) | The result of the evaluation is TRUE, when the variable selected in <i>13-10 Comparator Operand</i> is smaller than the fixed value in <i>13-12 Comparator Value</i> . The result is FALSE, if the variable selected in <i>13-10 Comparator Operand</i> is greater than the fixed value in <i>13-12 Comparator Value</i> . |
| [1] | Approx.Equal (~) | The result of the evaluation is TRUE, when the variable speed selected in <i>13-10 Comparator Operand</i> is approximately equal to the fixed value in <i>13-12 Comparator Value</i> . |
| [2] | Greater Than (>) | Inverse logic of [0] <i>Less Than (<)</i> . |

| 13-12 Comparator Value | | |
|------------------------|--|--|
| Range: | Function: | |
| 0 * [-9999 - 9999] | Enter the "trigger level" for the variable that is monitored by this comparator. This is an array parameter containing comparator values 0 to 5. | |

3.10.4 13-2* Timers

Use the result (TRUE or FALSE) from *timers* directly to define an *event* (see *13-51 SL Controller Event*), or as boolean input in a *logic rule* (see *13-40 Logic Rule Boolean 1*, *13-42 Logic Rule Boolean 2* or *13-44 Logic Rule Boolean 3*). A timer is only FALSE when started by an action (i.e. [29] *Start timer 1*) until the timer value entered in this parameter is elapsed. Then it becomes TRUE again.

All parameters in this parameter group are array parameters with index 0 to 2. Select index 0 to program Timer 0, select index 1 to program Timer 1, and so on.

| 13-20 SL Controller Timer | | |
|---------------------------|--|--|
| Range: | Function: | |
| 0 s* [0 - 3600 s] | Enter the value to define the duration of the FALSE output from the programmed timer. A timer is only FALSE if it is started by an action (i.e. [29] <i>Start timer 1</i>) and until the given timer value has elapsed. | |



3.10.5 13-4* Logic Rules

Combine up to three boolean inputs (TRUE/FALSE inputs) from timers, comtors, digital inputs, status bits and events using the logical operators AND, OR, and NOT. Select boolean inputs for the calculation in *13-40 Logic Rule Boolean 1*, *13-42 Logic Rule Boolean 2* and *13-44 Logic Rule Boolean 3*. Define the operators used to logically combine the selected inputs in *13-41 Logic Rule Operator 1* and *13-43 Logic Rule Operator 2*.

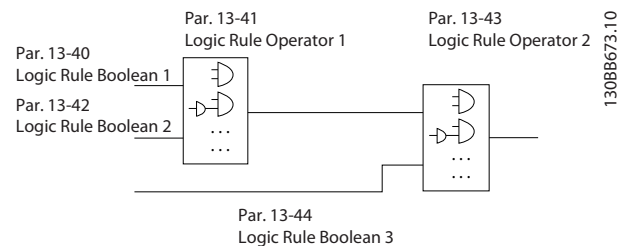

Illustration 3.22 Logic Rules

Priority of calculation

The results of *13-40 Logic Rule Boolean 1*, *13-41 Logic Rule Operator 1* and *13-42 Logic Rule Boolean 2* are calculated first. The outcome (TRUE/FALSE) of this calculation is combined with the settings of *13-43 Logic Rule Operator 2* and *13-44 Logic Rule Boolean 3*, yielding the final result (TRUE/FALSE) of the logic rule.

| 13-40 Logic Rule Boolean 1 | | |
|----------------------------|----------------------|--|
| Option: | Function: | |
| | | Select the first boolean (TRUE or FALSE) input for the selected logic rule. See <i>13-01 Start Event ([0]-[61])</i> and <i>13-02 Stop Event ([70]-[74])</i> for further description. |
| [0] | False | |
| [1] | True | |
| [2] | Running | |
| [3] | In range | |
| [4] | On reference | |
| [7] | Out of current range | |

| 13-40 Logic Rule Boolean 1 | | |
|----------------------------|--------------------|--|
| Option: | Function: | |
| [8] | Below I low | |
| [9] | Above I high | |
| [16] | Thermal warning | |
| [17] | Mains out of range | |
| [18] | Reversing | |
| [19] | Warning | |
| [20] | Alarm (trip) | |
| [21] | Alarm (trip lock) | |
| [22] | Comparator 0 | |
| [23] | Comparator 1 | |
| [24] | Comparator 2 | |
| [25] | Comparator 3 | |
| [26] | Logic rule 0 | |
| [27] | Logic rule 1 | |
| [28] | Logic rule 2 | |
| [29] | Logic rule 3 | |
| [30] | SL Time-out 0 | |
| [31] | SL Time-out 1 | |
| [32] | SL Time-out 2 | |
| [33] | Digital input DI18 | |
| [34] | Digital input DI19 | |
| [35] | Digital input DI27 | |
| [36] | Digital input DI29 | |
| [39] | Start command | |
| [40] | Drive stopped | |
| [42] | Auto Reset Trip | |
| [50] | Comparator 4 | |
| [51] | Comparator 5 | |
| [60] | Logic rule 4 | |
| [61] | Logic rule 5 | |
| [70] | SL Time-out 3 | |
| [71] | SL Time-out 4 | |
| [72] | SL Time-out 5 | |
| [73] | SL Time-out 6 | |
| [74] | SL Time-out 7 | |
| [83] | Broken Belt | |

| 13-41 Logic Rule Operator 1 | | |
|-----------------------------|-----------|--|
| Option: | Function: | |
| | | Select the first logical operator to use on the boolean inputs from 13-40 Logic Rule Boolean 1 and 13-42 Logic Rule Boolean 2. |
| [0] | Disabled | Ignores 13-42 Logic Rule Boolean 2, 13-43 Logic Rule Operator 2 and 13-44 Logic Rule Boolean 3. |
| [1] | AND | Evaluates the expression [13-40] AND [13-42]. |
| [2] | OR | Evaluates the expression [13-40] OR [13-42]. |
| [3] | AND NOT | Evaluates the expression [13-40] AND NOT [13-42]. |
| [4] | OR NOT | Evaluates the expression [13-40] OR NOT [13-42]. |

| 13-41 Logic Rule Operator 1 | | |
|-----------------------------|-------------|---|
| Option: | Function: | |
| [5] | NOT AND | Evaluates the expression NOT [13-40] AND [13-42]. |
| [6] | NOT OR | Evaluates the expression NOT [13-40] OR [13-42]. |
| [7] | NOT AND NOT | Evaluates the expression NOT [13-40] AND NOT [13-42]. |
| [8] | NOT OR NOT | Evaluates the expression NOT [13-40] OR NOT [13-42]. |

| 13-42 Logic Rule Boolean 2 | | |
|----------------------------|----------------------|---|
| Option: | Function: | |
| | | Select the second boolean (TRUE or FALSE) input for the selected logic rule. See 13-01 Start Event ([0]-[61]) and 13-02 Stop Event ([70]-[74]) for further description. |
| [0] | False | |
| [1] | True | |
| [2] | Running | |
| [3] | In range | |
| [4] | On reference | |
| [7] | Out of current range | |
| [8] | Below I low | |
| [9] | Above I high | |
| [16] | Thermal warning | |
| [17] | Mains out of range | |
| [18] | Reversing | |
| [19] | Warning | |
| [20] | Alarm (trip) | |
| [21] | Alarm (trip lock) | |
| [22] | Comparator 0 | |
| [23] | Comparator 1 | |
| [24] | Comparator 2 | |
| [25] | Comparator 3 | |
| [26] | Logic rule 0 | |
| [27] | Logic rule 1 | |
| [28] | Logic rule 2 | |
| [29] | Logic rule 3 | |
| [30] | SL Time-out 0 | |
| [31] | SL Time-out 1 | |
| [32] | SL Time-out 2 | |
| [33] | Digital input DI18 | |
| [34] | Digital input DI19 | |
| [35] | Digital input DI27 | |
| [36] | Digital input DI29 | |
| [39] | Start command | |
| [40] | Drive stopped | |
| [42] | Auto Reset Trip | |
| [50] | Comparator 4 | |
| [51] | Comparator 5 | |
| [60] | Logic rule 4 | |

| 13-42 Logic Rule Boolean 2 | | |
|----------------------------|---------------|--|
| Option: | Function: | |
| [61] | Logic rule 5 | |
| [70] | SL Time-out 3 | |
| [71] | SL Time-out 4 | |
| [72] | SL Time-out 5 | |
| [73] | SL Time-out 6 | |
| [74] | SL Time-out 7 | |
| [83] | Broken Belt | |

| 13-43 Logic Rule Operator 2 | | |
|-----------------------------|-------------|---|
| Option: | Function: | |
| | | Select the second logical operator to be used on the boolean input calculated in 13-40 Logic Rule Boolean 1, 13-41 Logic Rule Operator 1 and 13-42 Logic Rule Boolean 2, and the boolean input coming from 13-42 Logic Rule Boolean 2. [13-42] signifies the boolean input of 13-44 Logic Rule Boolean 3. [13-40/13-42] signify the boolean input calculated in 13-40 Logic Rule Boolean 1, 13-41 Logic Rule Operator 1 and 13-42 Logic Rule Boolean 2. |
| [0] | Disabled | Ignores 13-44 Logic Rule Boolean 3. |
| [1] | AND | |
| [2] | OR | |
| [3] | AND NOT | |
| [4] | OR NOT | |
| [5] | NOT AND | |
| [6] | NOT OR | |
| [7] | NOT AND NOT | |
| [8] | NOT OR NOT | |

| 13-44 Logic Rule Boolean 3 | | |
|----------------------------|----------------------|---|
| Option: | Function: | |
| | | Select the third boolean (TRUE or FALSE) input for the selected logic rule. See 13-40 Logic Rule Boolean 1, 13-41 Logic Rule Operator 1 and 13-42 Logic Rule Boolean 2, and the boolean input. See 13-01 Start Event ([0]-[61]) and 13-02 Stop Event ([70]-[74]) for further description. |
| [0] | False | |
| [1] | True | |
| [2] | Running | |
| [3] | In range | |
| [4] | On reference | |
| [7] | Out of current range | |
| [8] | Below I low | |
| [9] | Above I high | |
| [16] | Thermal warning | |
| [17] | Mains out of range | |
| [18] | Reversing | |
| [19] | Warning | |

| 13-44 Logic Rule Boolean 3 | | |
|----------------------------|--------------------|--|
| Option: | Function: | |
| [20] | Alarm (trip) | |
| [21] | Alarm (trip lock) | |
| [22] | Comparator 0 | |
| [23] | Comparator 1 | |
| [24] | Comparator 2 | |
| [25] | Comparator 3 | |
| [26] | Logic rule 0 | |
| [27] | Logic rule 1 | |
| [28] | Logic rule 2 | |
| [29] | Logic rule 3 | |
| [30] | SL Time-out 0 | |
| [31] | SL Time-out 1 | |
| [32] | SL Time-out 2 | |
| [33] | Digital input DI18 | |
| [34] | Digital input DI19 | |
| [35] | Digital input DI27 | |
| [36] | Digital input DI29 | |
| [39] | Start command | |
| [40] | Drive stopped | |
| [42] | Auto Reset Trip | |
| [50] | Comparator 4 | |
| [51] | Comparator 5 | |
| [60] | Logic rule 4 | |
| [61] | Logic rule 5 | |
| [70] | SL Time-out 3 | |
| [71] | SL Time-out 4 | |
| [72] | SL Time-out 5 | |
| [73] | SL Time-out 6 | |
| [74] | SL Time-out 7 | |
| [83] | Broken Belt | |

3.10.6 13-5* States

| 13-51 SL Controller Event | | |
|---------------------------|----------------------|---|
| Option: | Function: | |
| | | Select the third boolean (TRUE or FALSE) input for the selected logic rule. See 13-40 Logic Rule Boolean 1, 13-41 Logic Rule Operator 1 and 13-42 Logic Rule Boolean 2, and the boolean input. See 13-01 Start Event ([0]-[61]) and 13-02 Stop Event ([70]-[74]) for further description. |
| [0] | False | |
| [1] | True | |
| [2] | Running | |
| [3] | In range | |
| [4] | On reference | |
| [7] | Out of current range | |
| [8] | Below I low | |
| [9] | Above I high | |

| 13-51 SL Controller Event | |
|---------------------------|--------------------|
| Option: | Function: |
| [16] | Thermal warning |
| [17] | Mains out of range |
| [18] | Reversing |
| [19] | Warning |
| [20] | Alarm (trip) |
| [21] | Alarm (trip lock) |
| [22] | Comparator 0 |
| [23] | Comparator 1 |
| [24] | Comparator 2 |
| [25] | Comparator 3 |
| [26] | Logic rule 0 |
| [27] | Logic rule 1 |
| [28] | Logic rule 2 |
| [29] | Logic rule 3 |
| [30] | SL Time-out 0 |
| [31] | SL Time-out 1 |
| [32] | SL Time-out 2 |
| [33] | Digital input DI18 |
| [34] | Digital input DI19 |
| [35] | Digital input DI27 |
| [36] | Digital input DI29 |
| [39] | Start command |
| [40] | Drive stopped |
| [42] | Auto Reset Trip |
| [50] | Comparator 4 |
| [51] | Comparator 5 |
| [60] | Logic rule 4 |
| [61] | Logic rule 5 |
| [70] | SL Time-out 3 |
| [71] | SL Time-out 4 |
| [72] | SL Time-out 5 |
| [73] | SL Time-out 6 |
| [74] | SL Time-out 7 |
| [83] | Broken Belt |

| 13-52 SL Controller Action | |
|----------------------------|---|
| Option: | Function: |
| [0] | Disabled Select the action corresponding to the SLC event. Actions are executed when the corresponding event (defined in 13-51 SL Controller Event) is evaluated as true. |
| [1] | No action |
| [2] | Select set-up 1 Changes the active set-up (0-10 Active Set-up) to '1'. If the set-up is changed, it will merge with other set-up commands coming from either the digital inputs or via a fieldbus. |
| [3] | Select set-up 2 Changes the active set-up (0-10 Active Set-up) to '2'. If the set-up is changed, it will merge with other set-up commands coming from either the digital inputs or via a fieldbus. |

| 13-52 SL Controller Action | |
|----------------------------|---|
| Option: | Function: |
| [10] | Select preset ref 0 Select preset reference 0. If the active preset reference is changed, it will merge with other preset reference commands coming from either the digital inputs or via a fieldbus. |
| [11] | Select preset ref 1 Selects preset reference 1. If the active preset reference is changed, it will merge with other preset reference commands coming from either the digital inputs or via a fieldbus. |
| [12] | Select preset ref 2 Selects preset reference 2. If the active preset reference is changed, it will merge with other preset reference commands coming from either the digital inputs or via a fieldbus. |
| [13] | Select preset ref 3 Selects preset reference 3. If the active preset reference is changed, it will merge with other preset reference commands coming from either the digital inputs or via a fieldbus. |
| [14] | Select preset ref 4 Selects preset reference 4. If the active preset reference is changed, it will merge with other preset reference commands coming from either the digital inputs or via a fieldbus. |
| [15] | Select preset ref 5 Selects preset reference 5. If the active preset reference is changed, it will merge with other preset reference commands coming from either the digital inputs or via a fieldbus. |
| [16] | Select preset ref 6 Selects preset reference 6. If the active preset reference is changed, it will merge with other preset reference commands coming from either the digital inputs or via a fieldbus. |
| [17] | Select preset ref 7 Selects preset reference 7. If the active preset reference is changed, it will merge with other preset reference commands coming from either the digital inputs or via a fieldbus. |
| [18] | Select ramp 1 Selects ramp 1. |
| [19] | Select ramp 2 Selects ramp 2. |
| [22] | Run Issues a start command to the frequency converter. |
| [23] | Run reverse Issues a start reverse command to the frequency converter. |
| [24] | Stop Issues a stop command to the frequency converter. |
| [25] | Qstop Issues a quick stop command to the frequency converter. |

| 13-52 SL Controller Action | | |
|----------------------------|------------------------|---|
| Option: | Function: | |
| [26] | DC Brake | Issues a DC brake command to the frequency converter. |
| [27] | Coast | The frequency converter coasts immediately. All stop commands including the coast command stop the SLC. |
| [28] | Freeze output | Freezes the output of the frequency converter. |
| [29] | Start timer 0 | See 13-20 <i>SL Controller Timer</i> for further description. |
| [30] | Start timer 1 | See 13-20 <i>SL Controller Timer</i> for further description. |
| [31] | Start timer 2 | See 13-20 <i>SL Controller Timer</i> for further description. |
| [32] | Set digital out A low | Any output with SL output A will be low. |
| [33] | Set digital out B low | Any output with SL output B will be low. |
| [34] | Set digital out C low | Any output with SL output C will be low. |
| [35] | Set digital out D low | Any output with SL output D will be low. |
| [38] | Set digital out A high | Any output with SL output A will be high. |
| [39] | Set digital out B high | Any output with SL output B will be high. |
| [40] | Set digital out C high | Any output with SL output C will be high. |
| [41] | Set digital out D high | Any output with SL output D will be high. |
| [60] | Reset Counter A | Resets Counter A to zero. |
| [61] | Reset Counter B | Resets Counter B to zero. |
| [70] | Start Timer 3 | See 13-20 <i>SL Controller Timer</i> for further description. |
| [71] | Start Timer 4 | See 13-20 <i>SL Controller Timer</i> for further description. |
| [72] | Start Timer 5 | See 13-20 <i>SL Controller Timer</i> for further description. |
| [73] | Start Timer 6 | See 13-20 <i>SL Controller Timer</i> for further description. |
| [74] | Start Timer 7 | See 13-20 <i>SL Controller Timer</i> for further description. |

3.11 Parameters: 14-** Special Functions

3.11.1 14-0* Inverter Switching

| 14-01 Switching Frequency | | |
|---------------------------|-----------|---|
| Option: | Function: | |
| | | Select the inverter switching frequency. Changing the switching frequency can help to reduce acoustic noise from the motor. |
| [0] | Ran3 | 3 kHz true random PWM (white noise modulation). |
| [1] | Ran5 | 5 kHz true random PWM (white noise modulation). |
| [2] | 2.0 kHz | |
| [3] | 3.0 kHz | |
| [4] | 4.0 kHz | |
| [5] | 5.0 kHz | |
| [6] | 6.0 kHz | |
| [7] | 8.0 kHz | |
| [8] | 10.0 kHz | |
| [9] | 12.0kHz | |
| [10] | 16.0kHz | |

| 14-03 Overmodulation | | |
|----------------------|-----------|---|
| Option: | Function: | |
| [0] | Off | Select [0] Off for no overmodulation of the output voltage, in order to avoid torque ripple on the motor shaft. This feature may be useful for applications such as grinding machines. |
| [1] | On | Select [1] On to enable the overmodulation function for the output voltage. This is the right choice when it is required that the output voltage is higher than 95% of the input voltage (typical when running over-synchronously). The output voltage is increased according to the degree of overmodulation. NOTE Overmodulation leads to increased torque ripple as harmonics are increased. |

| 14-08 Damping Gain Factor | | |
|---------------------------|-------------|--|
| Range: | Function: | |
| 96 %* | [0 - 100 %] | Damping factor for DC link voltage compensation. |

3.11.2 14-1* Mains On/Off

Parameters for configuring mains failure monitoring and handling. If a mains failure appears, the frequency converter will try to continue in a controlled way until the power in the DC link has been exhausted.

| 14-10 Mains Failure | | |
|---------------------|-----------------------|---|
| Option: | Function: | |
| | | NOTE 14-10 Mains Failure cannot be changed while motor is running. <i>14-10 Mains Failure</i> is typically used where very short mains interruptions (voltage dips) are present. At 100% load and a short voltage interruption, the DC voltage on the main capacitors drops quickly. For larger frequency converters it only takes a few milliseconds before the DC level is down to about 373 V DC and the IGBTs cut off and loses the control over the motor. When the mains is restored, and the IGBTs start again, the output frequency and voltage vector does not correspond to the speed/frequency of the motor, and the result is normally an overvoltage or overcurrent, mostly resulting in a trip lock. <i>14-10 Mains Failure</i> can be programmed to avoid this situation. Select the function to which the frequency converter must act when the threshold in <i>14-11 Mains Voltage at Mains Fault</i> has been reached. |
| [0] | No function | The frequency converter will not compensate for a mains interruption. The voltage on the DC-link will drop quickly and motor control will be lost within milliseconds to seconds. Trip lock will be the result. |
| [1] | Ctrl. ramp-down | The frequency converter will remain control of the motor and do a controlled ramp down from <i>14-11 Mains Voltage at Mains Fault</i> level. If <i>2-10 Brake Function</i> is [0] Off or [2] AC brake, the ramp will follow the Over Voltage Ramping. If <i>2-10 Brake Function</i> is [1] Resistor Brake the ramp will follow the setting in <i>3-81 Quick Stop Ramp Time</i> . This selection is particularly useful in pump applications, where the inertia is low and the friction is high. When the mains is restored, the output frequency will ramp the motor up to the reference speed (if the mains interruption is prolonged, the controlled ramp down might take the output frequency all the way down to 0 RPM, and when the mains is restored, the application is ramped up from 0rpm to the previous reference speed via the normal ramp up). If the energy in the DC-link disappears before the motor is ramped to zero the motor will be coasted. |
| [2] | Ctrl. ramp-down, trip | This selection is similar to selection [1] except that in [2] a reset is necessary for starting up after power-up. |

| 14-10 Mains Failure | | | | | | | | | | | | |
|---------------------|---------------------------|--|---|------------------|---|---------------|---|-----------------|---|--------------|---|---------------------------|
| Option: | Function: | | | | | | | | | | | |
| [3] | Coasting | Centrifuges can run for an hour without power supply. In those situations it is possible to select a coast function at mains interruption, together with a flying start which occurs when the mains is restored. | | | | | | | | | | |
| [4] | Kinetic back-up | <p>Kinetic back-up ensures that the frequency converter keeps running as long as there is energy in the system due to the inertia from motor and load. This is done by converting the mechanical energy to the DC-link and thereby maintaining control of the drive and motor. This can extend the controlled operation, depending on the inertia in the system. For fans it is typically several seconds, for pumps up to 2 seconds and for compressors only for a fraction of a second. Many industry applications can extend controlled operation for many seconds, which is often enough time for the mains to return.</p> <p>Illustration 3.23 Kinetic Back-up</p> <table border="1"> <tr><td>A</td><td>Normal operation</td></tr> <tr><td>B</td><td>Mains failure</td></tr> <tr><td>C</td><td>Kinetic back-up</td></tr> <tr><td>D</td><td>Mains return</td></tr> <tr><td>E</td><td>Normal Operation: ramping</td></tr> </table> <p>Table 3.6 Legend to Illustration 3.23</p> <p>The DC-level during [4] Kinetic back-up is 14-11 Mains Voltage at Mains Fault * 1.35. If the mains do not return U_{DC} is maintained as long as possible by ramping the speed down towards 0 RPM. Finally the frequency converter coasts.</p> <p>If the mains return while in kinetic back-up U_{DC} will increase above 14-11 Mains Voltage at Mains Fault*1.35. This is detected in one of the following ways.</p> <ol style="list-style-type: none"> 1. If U_{DC} > 14-11 Mains Voltage at Mains Fault*1.35*1.05 2. If the speed is above the reference. This is relevant if the mains come back at a lower level than before, e.g. 14-11 Mains | A | Normal operation | B | Mains failure | C | Kinetic back-up | D | Mains return | E | Normal Operation: ramping |
| A | Normal operation | | | | | | | | | | | |
| B | Mains failure | | | | | | | | | | | |
| C | Kinetic back-up | | | | | | | | | | | |
| D | Mains return | | | | | | | | | | | |
| E | Normal Operation: ramping | | | | | | | | | | | |

| 14-10 Mains Failure | | | | | | | | | | |
|---------------------|-----------------------|--|---|------------------|---|---------------|---|-----------------|---|------|
| Option: | Function: | | | | | | | | | |
| | | <p>Voltage at Mains Fault*1.35*1.02. This does not fulfil the criterion in point one and the frequency converter will try to reduce U_{DC} to 14-11 Mains Voltage at Mains Fault*1.35 by increasing the speed. This will not succeed as the mains cannot be lowered.</p> <ol style="list-style-type: none"> 3. If running motoric. The same mechanism as in point two, but where the inertia will prevent that the speed goes above the reference speed. This will lead to the motor running motoric until the speed is above the reference speed and the situation in point two occurs. Instead of waiting for that criterion three is introduced. | | | | | | | | |
| [5] | Kinetic back-up, trip | <p>The difference between kinetic back-up with and without trip is that the latter will always ramp down to 0 RPM and trip, regardless of whether mains return or not.</p> <p>The function is made so that it will not even detect if mains return, this is the reason for the relatively high level on the DC-link during ramp down.</p> <p>Illustration 3.24 Kinetic Back-up Trip</p> <table border="1"> <tr><td>A</td><td>Normal Operation</td></tr> <tr><td>B</td><td>Mains failure</td></tr> <tr><td>C</td><td>Kinetic back-up</td></tr> <tr><td>D</td><td>Trip</td></tr> </table> <p>Table 3.7 Legend to Illustration 3.24</p> | A | Normal Operation | B | Mains failure | C | Kinetic back-up | D | Trip |
| A | Normal Operation | | | | | | | | | |
| B | Mains failure | | | | | | | | | |
| C | Kinetic back-up | | | | | | | | | |
| D | Trip | | | | | | | | | |
| [6] | Alarm | | | | | | | | | |

| 14-11 Mains Voltage at Mains Fault | | |
|------------------------------------|--|--|
| Range: | Function: | |
| 342 V* [100 - 800 V] | This parameter defines the threshold voltage at which the selected function in 14-10 Mains Failure should be activated. The detection level is at a factor sqrt ² of the value in this parameter. | |

| 14-12 Function at Mains Imbalance | | |
|-----------------------------------|-----------|---|
| Option: | Function: | |
| | | Operation under severe mains imbalance conditions reduces the lifetime of the motor. Conditions are considered severe if the motor is operated continuously near nominal load (e.g. a pump or fan running near full speed). |
| [0] | Trip | Trips the frequency converter. |
| [1] | Warning | Issues a warning. |
| [2] | Disabled | No action is taken. |
| [3] | Derate | Derates the frequency converter. |

| 14-15 Kin. Backup Trip Recovery Level | | |
|---------------------------------------|--|---|
| Range: | Function: | |
| 60000.000 Reference-FeedbackUnit* | [0 - 60000.000 ReferenceFeed-backUnit] | This parameter specifies the kinetic back-up trip recovery level. |

3.11.3 14-2* Trip Reset

Parameters for configuring auto reset handling, special trip handling and control card self test or initialisation.

| 14-20 Reset Mode | | |
|------------------|---------------------|--|
| Option: | Function: | |
| | | <p>NOTE</p> <p>The motor may start without warning. If the specified number of AUTOMATIC RESETs is reached within 10 minutes, the frequency converter enters [0] Manual reset mode. After the Manual reset is performed, the setting of 14-20 Reset Mode reverts to the original selection. If the number of automatic resets is not reached within 10 minutes, or when a Manual reset is performed, the internal AUTOMATIC RESET counter returns to zero.</p> <p>Select the reset function after tripping. Once reset, the frequency converter can be restarted.</p> |
| [0] | Manual reset | Select [0] Manual reset, to perform a reset via [Reset] or via the digital inputs. |
| [1] | Automatic reset x 1 | Select [1]-[12] Automatic reset x 1...x20 to perform between one and twenty automatic resets after tripping. |
| [2] | Automatic reset x 2 | |

| 14-20 Reset Mode | | |
|------------------|----------------------|---|
| Option: | Function: | |
| [3] | Automatic reset x 3 | |
| [4] | Automatic reset x 4 | |
| [5] | Automatic reset x 5 | |
| [6] | Automatic reset x 6 | |
| [7] | Automatic reset x 7 | |
| [8] | Automatic reset x 8 | |
| [9] | Automatic reset x 9 | |
| [10] | Automatic reset x 10 | |
| [11] | Automatic reset x 15 | |
| [12] | Automatic reset x 20 | |
| [13] | Infinite auto reset | Select [13] Infinite Automatic Reset for continuous resetting after tripping. |
| [14] | Reset at power-up | |

| 14-21 Automatic Restart Time | | |
|------------------------------|-------------|--|
| Range: | Function: | |
| 10 s* | [0 - 600 s] | Enter the time interval from trip to start of the automatic reset function. This parameter is active when 14-20 Reset Mode is set to [1] - [13] Automatic reset. |

| 14-22 Operation Mode | | |
|----------------------|------------------|---|
| Option: | Function: | |
| | | Specify normal operation, perform tests or initialise all parameters except for 15-03 Power Up's, 15-04 Over Temp's, and 15-05 Over Volt's. This function is only active when the power is cycled to the frequency converter. |
| [0] | Normal operation | Normal operation with motor selected. |
| [2] | Initialisation | Reset all parameter values to default settings, except for 15-03 Power Up's, 15-04 Over Temp's, and 15-05 Over Volt's. The frequency converter will reset during the next power-up. |

| 14-23 Typecode Setting | | |
|------------------------|------------|--|
| Range: | Function: | |
| 0 * | [0 - 255] | Use this parameter for setting the typecode matching the specific frequency converter. |

| 14-24 Trip Delay at Current Limit | | |
|-----------------------------------|------------|--|
| Range: | Function: | |
| 60 s* | [0 - 60 s] | Enter the current limit trip delay in seconds. When the output current reaches the current limit (4-18 Current Limit), a warning is triggered. When the current limit warning has been continuously present for the period specified in this parameter, the frequency converter trips. To run continuously in current limit without tripping, set the parameter to 60 s = Off. Thermal monitoring of the frequency converter will still remain active. |

| 14-25 Trip Delay at Torque Limit | | |
|----------------------------------|--|--|
| Range: | Function: | |
| 60 s* [0 - 60 s] | Enter the torque limit trip delay in seconds. When the output torque reaches the torque limits (4-16 <i>Torque Limit Motor Mode</i> and 4-17 <i>Torque Limit Generator Mode</i>), a warning is triggered. When the torque limit warning has been continuously present for the period specified in this parameter, the frequency converter trips. Disable the trip delay by setting the parameter to 60 s = Off. Thermal monitoring of the frequency converter will still remain active. | |

| 14-27 Action At Inverter Fault | | |
|--------------------------------|--|---|
| Option: | Function: | |
| | Select how the frequency converter should react at inverter fault. | |
| [0] | Trip | The frequency converter trips. |
| [1] | Warning | The frequency converter issues a warning. |

| 14-28 Production Settings | | |
|---------------------------|----------------|--|
| Option: | Function: | |
| [0] | No action | |
| [1] | Service reset | |
| [3] | Software Reset | |

| 14-29 Service Code | | |
|--------------------|-------------------|------------------------|
| Range: | Function: | |
| 0 * | [0 - 0x7FFFFFFF] | For internal use only. |

3.11.4 14-3* Current Limit Control

The frequency converter features an integral Current Limit Controller which is activated when the motor current, and thus the torque, is higher than the torque limits set in 4-16 *Torque Limit Motor Mode* and 4-17 *Torque Limit Generator Mode*.

When the current limit is reached during motor operation or regenerative operation, the frequency converter will try to reduce torque below the preset torque limits as quickly as possible without losing control of the motor.

While the current control is active, the frequency converter can only be stopped by setting a digital input to [2] *Coast inverse* or [3] *Coast and reset inv.* Any signal on terminals 18 to 33 will not be active until the frequency converter is no longer near the current limit.

By using a digital input set to [2] *Coast inverse* or [3] *Coast and reset inv.*, the motor does not use the ramp-down time, since the frequency converter is coasted. If a quick stop is necessary, use the mechanical brake control function along with an external electro-mechanical brake attached to the application.

| 14-30 Current Lim Ctrl, Proportional Gain | | |
|---|-------------|--|
| Range: | Function: | |
| 100 %* | [0 - 500 %] | Enter the proportional gain value for the current limit controller. Selection of a high value makes the controller react faster. Too high a setting leads to controller instability. |

| 14-31 Current Lim Ctrl, Integration Time | | |
|--|-----------|---|
| Range: | Function: | |
| 0.020 s* | [0 - 2 s] | Controls the current limit control integration time. Setting it to a lower value makes it react faster. A setting too low leads to control instability. |

| 14-32 Current Lim Ctrl, Filter Time | | |
|-------------------------------------|--------------|--|
| Range: | Function: | |
| 10 ms* | [2 - 100 ms] | Sets a time constant for the current limit controller low-pass filter. |

3.11.5 14-4* Energy Optimising

Parameters for adjusting the energy optimisation level in both Variable Torque (VT) and Automatic Energy Optimization (AEO) mode in 1-03 *Torque Characteristics*.

| 14-40 VT Level | | |
|----------------|-------------|---|
| Range: | Function: | |
| 66 %* | [40 - 90 %] | <p>NOTE This parameter cannot be adjusted while the motor is running.</p> <p>Enter the level of motor magnetisation at low speed. Selection of a low value reduces energy loss in the motor, but also reduces load capability.</p> |

NOTE

This parameter is not active when 1-10 *Motor Construction* is set to [1] *PM non salient SPM*.

| 14-41 AEO Minimum Magnetisation | | |
|---------------------------------|-------------|--|
| Range: | Function: | |
| 66 %* | [40 - 75 %] | Enter the minimum allowable magnetisation for AEO. Selection of a low value reduces energy loss in the motor, but can also reduce resistance to sudden load changes. |

3.11.6 14-5* Environment

These parameters help the frequency converter to operate under special environmental conditions.

3

| 14-50 RFI Filter | | |
|------------------|-----------|--|
| Option: | Function: | |
| [0] | Off | |
| [1] | On | |
| [2] | Grid type | |

| 14-51 DC-Link Voltage Compensation | | |
|------------------------------------|-----------|--------------------------------|
| Option: | Function: | |
| [0] | Off | Disables DC link compensation. |
| [1] | On | Enables DC link compensation. |

| 14-52 Fan Control | | |
|-------------------|--------------------------------------|--|
| Option: | Function: | |
| [5] | Constant-on mode | |
| [6] | Constant-off mode | |
| [7] | On-when-Inverter-is-on-else-off Mode | |
| [8] | Variable-speed mode | |

| 14-55 Output Filter | | |
|---------------------|------------------|--|
| Option: | Function: | |
| | | NOTE This parameter cannot be changed while the motor is running. Select the type of output filter connected. |
| [0] | No Filter | Use this selection with dU/dt filters or high-frequency common-mode filters. |
| [1] | Sine-Wave Filter | |

| 14-63 Min Switch Frequency | | |
|----------------------------|-----------|--|
| Option: | Function: | |
| | | Set the minimum switch frequency allowed by the output filter. |
| [2] | 2.0 kHz | |
| [3] | 3.0 kHz | |
| [4] | 4.0 kHz | |
| [5] | 5.0 kHz | |
| [6] | 6.0 kHz | |
| [7] | 8.0 kHz | |
| [8] | 10.0 kHz | |
| [9] | 12.0kHz | |
| [10] | 16.0kHz | |

3.12 Parameters: 15-** Drive Information

3.12.1 15-0* Operating Data

| 15-00 Operating hours | | |
|-----------------------|--------------------|--|
| Range: | Function: | |
| 0 h* | [0 - 0x7ffffff. h] | View how many hours the frequency converter has run. The value is saved, when the frequency converter is turned off. |

| 15-01 Running Hours | | |
|---------------------|--------------------|--|
| Range: | Function: | |
| 0 h* | [0 - 0x7ffffff. h] | View how many hours the frequency converter has run. Reset the counter in <i>15-07 Reset Running Hours Counter</i> . The value is saved, when the frequency converter is turned off. |

| 15-02 kWh Counter | | |
|-------------------|----------------------|---|
| Range: | Function: | |
| 0 kWh* | [0 - 2147483647 kWh] | Registering the power consumption of the motor as a mean value over one hour. Reset the counter in <i>15-06 Reset kWh Counter</i> . |

| 15-03 Power Up's | | |
|------------------|-------------------|---|
| Range: | Function: | |
| 0 * | [0 - 2147483647] | View the number of times the frequency converter has been powered up. |

| 15-04 Over Temp's | | |
|-------------------|--------------|--|
| Range: | Function: | |
| 0 * | [0 - 65535] | View the number of frequency converter temperature faults which have occurred. |

| 15-05 Over Volt's | | |
|-------------------|--------------|--|
| Range: | Function: | |
| 0 * | [0 - 65535] | View the number of frequency converter overvoltages which have occurred. |

| 15-06 Reset kWh Counter | | |
|-------------------------|---------------|--|
| Option: | Function: | |
| [0] | Do not reset | Nno reset of the kWh counter is desired. |
| [1] | Reset counter | Press [OK] to reset the kWh counter to zero (see <i>15-02 kWh Counter</i>). |

NOTE

The reset is carried out by pressing [OK].

| 15-07 Reset Running Hours Counter | | |
|-----------------------------------|---------------|--|
| Option: | Function: | |
| [0] | Do not reset | |
| [1] | Reset counter | Press [OK] to reset the running hours counter to zero (see <i>15-01 Running Hours</i>). |

3.12.2 15-3* Alarm Log

Parameters in this group are array parameters, where up to 10 fault logs can be viewed. [0] is the most recent logged data, and [9] the oldest. Error codes, values, and time stamp can be viewed for all logged data.

| 15-30 Alarm Log: Error Code | | |
|-----------------------------|------------|---|
| Range: | Function: | |
| 0 * | [0 - 255] | View the error code and look up its meaning in <i>5 Troubleshooting</i> . |

| 15-31 InternalFaultReason | | |
|---------------------------|-------------------|--|
| Range: | Function: | |
| 0 * | [-32767 - 32767] | View an extra description of the error. This parameter is mostly used in combination with Alarm 38 Internal Fault. |

3.12.3 15-4* Drive Identification

Parameters containing read only information about the hardware and software configuration of the frequency converter.

| 15-40 FC Type | | |
|---------------|-----------|---|
| Range: | Function: | |
| 0 * | [0 - 0] | View the frequency converter type. The read-out is identical to the power field of the typecode definition, characters 1-6. |

| 15-41 Power Section | | |
|---------------------|-----------|---|
| Range: | Function: | |
| 0 * | [0 - 0] | View the FC type. The read-out is identical to the power field of the typecode definition, characters 7-10. |

| 15-42 Voltage | | |
|---------------|-----------|---|
| Range: | Function: | |
| 0 * | [0 - 0] | View the FC type. The read-out is identical to the power field type of the typecode definition, characters 11-12. |

| 15-43 Software Version | | |
|------------------------|-----------|--|
| Range: | Function: | |
| 0 * | [0 - 0] | View the combined SW version (or 'package version') consisting of power SW and control SW. |

| 15-44 Ordered Typecode String | | |
|-------------------------------|-----------|---|
| Range: | Function: | |
| 0 * | [0 - 0] | View the type code string used for re-ordering the frequency converter in its original configuration. |

| 15-46 Drive Ordering No | | |
|-------------------------|-----------|--|
| Range: | Function: | |
| 0 * | [0 - 0] | View the 8-digit ordering number used for re-ordering the frequency converter in its original configuration. |

| 15-47 Power Card Ordering No | | |
|------------------------------|-----------|--------------------------------------|
| Range: | Function: | |
| 0 * | [0 - 0] | View the power card ordering number. |

| 15-48 LCP Id No | | |
|-----------------|-----------|-------------------------|
| Range: | Function: | |
| 0 * | [0 - 0] | View the LCP ID number. |

| 15-49 SW ID Control Card | | |
|--------------------------|-----------|--|
| Range: | Function: | |
| 0 * | [0 - 0] | View the control card software version number. |

| 15-50 SW ID Power Card | | |
|------------------------|-----------|--|
| Range: | Function: | |
| 0 * | [0 - 0] | View the power card software version number. |

| 15-51 Frequency Converter Serial Number | | |
|---|-----------|---|
| Range: | Function: | |
| 0 * | [0 - 0] | View the frequency converter serial number. |

| 15-53 Power Card Serial Number | | |
|--------------------------------|-----------|------------------------------------|
| Range: | Function: | |
| 0 * | [0 - 0] | View the power card serial number. |

| 15-92 Defined Parameters | | |
|--------------------------|-------------|---|
| Range: | Function: | |
| 0 * | [0 - 2000] | View a list of all defined parameters in the frequency converter. The list ends with 0. |

| 15-97 Application Type | | |
|------------------------|-------------------|--|
| Range: | Function: | |
| 0 * | [0 - 0xFFFFFFFF] | |

| 15-98 Drive Identification | | |
|----------------------------|-----------|--|
| Range: | Function: | |
| 0 * | [0 - 0] | |

3.13 Parameters: 16-** Data Read-outs

3.13.1 16-1* Motor Status

| 16-00 Control Word | | |
|--------------------|--|--|
| Range: | Function: | |
| 0 * [0 - 65535] | View the Control word sent from the frequency converter via the serial communication port in hex code. | |

| 16-01 Reference [Unit] | | |
|---------------------------|---------------------------------------|---|
| Range: | Function: | |
| 0 ReferenceFeed-backUnit* | [-4999 - 4999 ReferenceFeed-backUnit] | View the present reference value applied on impulse or analog basis in the unit resulting from the configuration selected in <i>1-00 Configuration Mode</i> . |

| 16-02 Reference [%] | | |
|---------------------|---|--|
| Range: | Function: | |
| 0 %* [-200 - 200 %] | View the total reference. The total reference is the sum of digital, analog, preset, bus, and freeze references, plus catch-up and slow-down. | |

| 16-03 Status Word | | |
|-------------------|---|--|
| Range: | Function: | |
| 0 * [0 - 65535] | View the Status word sent from the frequency converter via the serial communication port in hex code. | |

| 16-05 Main Actual Value [%] | | |
|-----------------------------|---|--|
| Range: | Function: | |
| 0 %* [-200 - 200 %] | View the 2-byte word sent with the status word to the bus master reporting the main actual value. | |

| 16-09 Custom Readout | | |
|----------------------|------------------------------|--|
| Range: | Function: | |
| 0 CustomReadoutUnit* | [0 - 9999 CustomReadoutUnit] | View the custom readout from <i>0-30 Custom Readout Unit</i> to <i>0-32 Custom Readout Max Value</i> . |

| 16-10 Power [kW] | | |
|---------------------|--|--|
| Range: | Function: | |
| 0 kW* [0 - 1000 kW] | Displays motor power in kW. The value shown is calculated on the basis of the actual motor voltage and motor current. The value is filtered, and therefore approx. 30 ms may pass from when an input value changes to when the data read-out values change. The resolution of read-out value on fieldbus is in 10 W steps. | |

| 16-11 Power [hp] | | |
|---------------------|---|--|
| Range: | Function: | |
| 0 hp* [0 - 1000 hp] | View the motor power in HP. The value shown is calculated on the basis of the actual motor voltage and motor current. The value is filtered, and therefore approximately 30 ms may pass from when an input value changes to when the data read-out values change. | |

| 16-12 Motor Voltage | | |
|---------------------|---|--|
| Range: | Function: | |
| 0 V* [0 - 65535 V] | View the motor voltage, a calculated value is used for controlling the motor. | |

| 16-13 Frequency | | |
|-----------------------|--|--|
| Range: | Function: | |
| 0 Hz* [0 - 6553.5 Hz] | View the motor frequency, without resonance dampening. | |

| 16-14 Motor current | | |
|---------------------|---|--|
| Range: | Function: | |
| 0 A* [0 - 655.35 A] | View the motor current measured as a mean value, I_{RMS} . The value is filtered, and thus approximately 30 ms may pass from when an input value changes to when the data read-out values change. | |

| 16-15 Frequency [%] | | |
|---------------------|---|--|
| Range: | Function: | |
| 0 %* [0 - 6553.5 %] | View a two-byte word reporting the actual motor frequency (without resonance dampening) as a percentage (scale 0000-4000 Hex) of <i>4-19 Max Output Frequency</i> . | |

| 16-18 Motor Thermal | | |
|---------------------|---|--|
| Range: | Function: | |
| 0 %* [0 - 100 %] | View the calculated thermal load on the motor. The cut-out limit is 100%. The basis | |

| 16-18 Motor Thermal | | |
|---------------------|--|--|
| Range: | Function: | |
| | for calculation is the ETR function selected in 1-90 Motor Thermal Protection. | |

3.13.2 16-3* Drive Status

| 16-30 DC Link Voltage | | |
|-----------------------|---------------|--|
| Range: | Function: | |
| 0 V* | [0 - 65535 V] | View a measured value. The value is filtered with a 30 ms time constant. |

| 16-33 Brake Energy /2 min | | |
|---------------------------|----------------|---|
| Range: | Function: | |
| 0 kW* | [0 - 10000 kW] | View the brake power transmitted to an external brake resistor. The mean power is calculated on an average basis for the most recent 120 s. |

| 16-34 Heatsink Temp. | | |
|----------------------|-----------------|--|
| Range: | Function: | |
| 0 °C* | [-128 - 127 °C] | View the frequency converter heat-sink temperature. The cut-out limit is 90 ±5 °C, and the motor cuts back in at 60 ±5 °C. |

| 16-35 Inverter Thermal | | |
|------------------------|-------------|---|
| Range: | Function: | |
| 0 %* | [0 - 255 %] | View the percentage load on the inverter. |

| 16-36 Inv. Nom. Current | | |
|-------------------------|----------------|--|
| Range: | Function: | |
| 0 A* | [0 - 655.35 A] | View the inverter nominal current, which should match the nameplate data on the connected motor. The data are used for calculation of torque, motor protection, etc. |

| 16-37 Inv. Max. Current | | |
|-------------------------|----------------|--|
| Range: | Function: | |
| 0 A* | [0 - 655.35 A] | View the inverter maximum current, which should match the nameplate data on the connected motor. The data are used for calculation of torque, motor protection, etc. |

| 16-38 SL Controller State | | |
|---------------------------|-----------|---|
| Range: | Function: | |
| 0 * | [0 - 20] | View the state of the event under execution by the SL controller. |

| 16-39 Control Card Temp. | | |
|--------------------------|----------------|---|
| Range: | Function: | |
| 0 °C* | [0 - 65535 °C] | View the temperature on the control card, stated in °C. |

3.13.3 16-5* Ref. & Feedb.

| 16-50 External Reference | | |
|--------------------------|----------------|---|
| Range: | Function: | |
| 0 %* | [-200 - 200 %] | View the total reference, the sum of digital, analog, preset, bus and freeze references, plus catch-up and slow-down. |

| 16-52 Feedback[Unit] | | |
|----------------------|--------------------------------|---|
| Range: | Function: | |
| 0 ProcessCtrlUnit* | [-4999 - 4999 ProcessCtrlUnit] | View the feedback unit resulting from the selection of unit and scaling in 3-00 Reference Range, 3-01 Reference/Feedback Unit, 3-02 Minimum Reference and 3-03 Maximum Reference. |

| 16-57 Feedback [RPM] | | |
|----------------------|----------------------|--|
| Range: | Function: | |
| 0 RPM* | [-30000 - 30000 RPM] | Read-out parameter where the actual motor RPM from the feed-back source can be read in both closed loop and open loop. The feed-back source is selected by 7-00 Speed PID Feedback Source. |

3.13.4 16-6* Inputs and Outputs

| 16-60 Digital Input | | |
|---------------------|--------------|--|
| Range: | Function: | |
| 0 * | [0 - 65535] | View the actual state of the digital inputs 18, 19, 27 and 29. |

| 16-60 Digital Input | | |
|----------------------------------|-----------|------------------------|
| Range: | Function: | |
| | Bit 0 | Unused |
| | Bit 1 | Unused |
| | Bit 2 | Digital input term. 29 |
| | Bit 3 | Digital input term. 27 |
| | Bit 4 | Digital input term. 19 |
| | Bit 5 | Digital input term. 18 |
| | Bit 6-15 | Unused |
| Table 3.8 Bits Definition | | |

| 16-61 Terminal 53 Setting | | |
|---------------------------|--|--|
| Option: | Function: | |
| | View the setting of input terminal 53. | |
| [0] | Current mode | |
| [1] | Voltage mode | |

| 16-62 Analog Input 53 | | |
|-----------------------|-----------|------------------------------------|
| Range: | Function: | |
| 1 * | [0 - 20] | View the actual value at input 53. |

| 16-63 Terminal 54 Setting | | |
|---------------------------|--|--|
| Option: | Function: | |
| | View the setting of input terminal 54. | |
| [0] | Current mode | |
| [1] | Voltage mode | |

| 16-64 Analog Input AI54 | | |
|-------------------------|-----------|------------------------------------|
| Range: | Function: | |
| 1 * | [0 - 20] | View the actual value at input 54. |

| 16-65 Analog Output 42 [mA] | | |
|-----------------------------|-------------|--|
| Range: | Function: | |
| 0 mA* | [0 - 20 mA] | View the actual value at output 42. The value shown reflects the selections in 6-90 Terminal 42 Mode and 6-91 Terminal 42 Analog Output. |

| 16-66 Digital Output | | |
|----------------------|-----------|---|
| Range: | Function: | |
| 0 * | [0 - 15] | View the binary value of all digital outputs. |

| 16-67 Pulse Input #29 [Hz] | | |
|----------------------------|---------------|--|
| Range: | Function: | |
| 0 * | [0 - 130000] | View the actual frequency rate on terminal 29. |

| 16-68 Pulse Input 33 [Hz] | | |
|---------------------------|---------------|--|
| Range: | Function: | |
| 0 * | [0 - 130000] | View the actual value of the frequency applied at terminal 33 as an impulse input. |

| 16-69 Pulse Output 27 [Hz] | | |
|----------------------------|--------------|--|
| Range: | Function: | |
| 0 * | [0 - 40000] | View the actual value of impulses applied to terminal 27 in digital output mode. |

| 16-70 Pulse Output 29 [Hz] | | |
|----------------------------|--------------|--|
| Range: | Function: | |
| 0 * | [0 - 40000] | View the actual value of pulses to terminal 29 in digital output mode. |

| 16-71 Relay Output | | |
|--------------------|--------------|----------------------------------|
| Range: | Function: | |
| 0 * | [0 - 65535] | View the settings of all relays. |

| 16-72 Counter A | | |
|-----------------|-------------------|--|
| Range: | Function: | |
| 0 * | [-32768 - 32767] | View the present value of Counter A. Counters are useful as comparator operands, see 13-10 Comparator Operand. The value can be reset or changed either via digital inputs (parameter group 5-1* Digital Inputs) or by using an SLC action (13-52 SL Controller Action). |

| 16-73 Counter B | | |
|-----------------|-------------------|---|
| Range: | Function: | |
| 0 * | [-32768 - 32767] | View the present value of Counter B. Counters are useful as comparator operands (13-10 Comparator Operand). The value can be reset or changed either via digital inputs (parameter group 5-1* Digital Inputs) or by using an SLC action (13-52 SL Controller Action). |

| 16-79 Analog Output AO45 | | |
|--------------------------|-------------|--|
| Range: | Function: | |
| 0 mA* | [0 - 20 mA] | |

3.13.5 16-8* Fieldbus & FC Port

Parameters for reporting the BUS references and control words.

| 16-86 FC Port REF 1 | | |
|---------------------|-------------------|--|
| Range: | Function: | |
| 0 * | [-32768 - 32767] | View the last received reference from the FC port. |

| 16-90 Alarm Word | | |
|------------------|----------------------|---|
| Range: | Function: | |
| 0 * | [0 - 0xFFFFFFFFFUL] | View the alarm word sent via the serial communication port in hex code. |

| 16-91 Alarm Word 2 | | |
|--------------------|----------------------|---|
| Range: | Function: | |
| 0 * | [0 - 0xFFFFFFFFFUL] | View the alarm word 2 sent via the serial communication port in hex code. |

| 16-92 Warning Word | | |
|--------------------|----------------------|---|
| Range: | Function: | |
| 0 * | [0 - 0xFFFFFFFFFUL] | View the warning word sent via the serial communication port in hex code. |

| 16-93 Warning Word 2 | | |
|----------------------|----------------------|---|
| Range: | Function: | |
| 0 * | [0 - 0xFFFFFFFFFUL] | View the warning word 2 sent via the serial communication port in hex code. |

| 16-94 Ext. Status Word | | |
|------------------------|----------------------|--|
| Range: | Function: | |
| 0 * | [0 - 0xFFFFFFFFFUL] | Returns the extended status word sent via the serial communication port in hex code. |

| 16-95 Ext. Status Word 2 | | |
|--------------------------|----------------------|--|
| Range: | Function: | |
| 0 * | [0 - 0xFFFFFFFFFUL] | Returns the extended status word 2 sent via the serial communication port in hex code. |

3.14 Parameters: 18-** Data Readouts 2

| 18-90 Process PID Error | | |
|-------------------------|----------------|--|
| Range: | Function: | |
| 0 %* | [-200 - 200 %] | |

| 18-91 Process PID Output | | |
|--------------------------|----------------|--|
| Range: | Function: | |
| 0 %* | [-200 - 200 %] | |

| 18-92 Process PID Clamped Output | | |
|----------------------------------|----------------|--|
| Range: | Function: | |
| 0 %* | [-200 - 200 %] | |

| 18-93 Process PID Gain Scaled Output | | |
|--------------------------------------|----------------|--|
| Range: | Function: | |
| 0 %* | [-200 - 200 %] | |

3.15 Parameters: 22-** Application Functions

3.15.1 22-4* Sleep Mode

The sequence when running sleep mode in Open Loop:

1. The motor speed is less than *22-47 Sleep Speed [Hz]* and the motor has been running longer than *22-40 Minimum Run Time*.
2. FC 360 ramps the motor speed down to *1-82 Min Speed for Function at Stop [Hz]*.
3. FC 360 activates *1-80 Function at Stop*. The frequency converter is now in sleep mode.
4. FC 360 compares the speed setpoint with *22-43 Wake-Up Speed [Hz]* to detect wake up situation.
5. The speed setpoint is greater than *22-43 Wake-Up Speed [Hz]* and the sleep condition has last for more than *22-41 Minimum Sleep Time*. The frequency converter is now out of sleep mode.
6. Go back to speed open loop control (ramp motor speed up to the speed setpoint).

The sequence when running sleep mode in Closed Loop:

1. If *20-81 PI Normal/ Inverse Control = [0] Normal*. When error between Reference and Feedback is greater than *22-44 Wake-Up Ref./FB Diff*, the frequency converter will go to Boost status. If *22-45 Setpoint Boost* is not set, the frequency converter will go into sleep mode.
2. After *22-46 Maximum Boost Time*, drive ramps the motor speed down to *1-82 Min Speed for Function at Stop [Hz]*.
3. The frequency converter activates *1-80 Function at Stop*. The frequency converter is now in Sleep mode.
4. When error between Reference and Feedback is greater than *22-44 Wake-Up Ref./FB Diff*, and the condition last more than *22-41 Minimum Sleep Time*, the frequency converter is out of sleep mode.
5. The frequency converter goes back to Close Loop control.

NOTE

Sleep Mode will not be active when Local Reference is active (set speed manually by means of navigation keys on the LCP).

Does not work in Hand-mode. Auto set-up in open loop must be carried out before setting input/output in closed loop.

| 22-40 Minimum Run Time | | |
|------------------------|-------------|---|
| Range: | | Function: |
| 10 s* | [0 - 600 s] | Set the desired minimum running time for the motor after a start command (digital input or Bus) before entering Sleep Mode. |

| 22-41 Minimum Sleep Time | | |
|--------------------------|-------------|--|
| Range: | | Function: |
| 10 s* | [0 - 600 s] | Set the desired Minimum Time for staying in Sleep Mode. This will override any wake up conditions. |

| 22-43 Wake-Up Speed [Hz] | | |
|--------------------------|--------------|-----------|
| Range: | | Function: |
| 10 * | [0 - 400.0] | |

| 22-44 Wake-Up Ref./FB Diff | | |
|----------------------------|-------------|---|
| Range: | | Function: |
| 10 %* | [0 - 100 %] | Only to be used if <i>1-00 Configuration Mode</i> is set for Closed Loop and the integrated PI controller is used for controlling the pressure. Set the pressure drop allowed in percentage of set point for the pressure (P_{set}) before cancelling the Sleep Mode. |

| 22-45 Setpoint Boost | | |
|----------------------|----------------|---|
| Range: | | Function: |
| 0 %* | [-100 - 100 %] | Only to be used if <i>1-00 Configuration Mode</i> , is set for Closed Loop and the integrated PI controller is used. In systems with e.g. constant pressure control, it is advantageous to increase the system pressure before the motor is stopped. This will extend the time in which the motor is stopped and help to avoid frequent start/stop. Set the desired over pressure/temperature in percentage of set point for the pressure (P_{set})/ temperature before entering the Sleep Mode. If setting for 5%, the boost pressure will be $P_{set} * 1.05$. The negative values can be used for e.g. cooling tower control where a negative change is needed. |

| 22-46 Maximum Boost Time | | |
|--------------------------|-------------|---|
| Range: | | Function: |
| 60 s* | [0 - 600 s] | Only to be used if <i>1-00 Configuration Mode</i> is set for Closed Loop and the integrated PI controller is used for controlling the pressure. Set the maximum time for which boost mode will be allowed. If the set time is exceeded, Sleep Mode will be entered, not waiting for the set boost pressure to be reached. |

| 22-47 Sleep Speed [Hz] | | |
|------------------------|---------------|--|
| Range: | | Function: |
| 0 * | [0 - 400.0] | Set the speed below which the frequency converter will go into Sleep Mode. |

3.15.2 22-6* Broken Belt Detection

The Broken Belt Detection can be used in both closed and open loop systems for pumps and fans. If the estimated motor torque (current) is below the broken belt torque (current) value (22-61 Broken Belt Torque) and the frequency converter output frequency is above or equal to 15 Hz, 22-60 Broken Belt Function is performed

| 22-60 Broken Belt Function | | |
|----------------------------|---------|---|
| Option: | | Function: |
| | | Select the actions to be performed if the broken belt condition is detected. |
| [0] | Off | |
| [1] | Warning | The frequency converter will continue to run, but activates a broken belt warning [W95]. A frequency converter digital output or a serial communication bus can communicate a warning to other equipment. |
| [2] | Trip | The frequency converter will stop running and activate a broken belt alarm [A95]. A frequency converter digital output or a serial communication bus can communicate an alarm to other equipment. |

| 22-61 Broken Belt Torque | | |
|--------------------------|---------------|--|
| Range: | | Function: |
| 10 %* | [5 - 100 %] | Sets the broken belt torque as a percentage of the rated motor torque. |

| 22-62 Broken Belt Delay | | |
|-------------------------|---------------|--|
| Range: | | Function: |
| 10 s* | [0 - 600 s] | Sets the time for which the broken belt conditions must be active before carrying out the action selected in 22-60 Broken Belt Function. |

3.16 Parameters: 30-** Special Features

| 30-83 Speed PID Proportional Gain | | |
|-----------------------------------|-----------|---|
| Range: | | Function: |
| Size related* | [0 - 1] | Enter the speed controller proportional gain. Quick control is obtained at high amplification. However, if amplification is too great, the process may become unstable. |

4 Parameter Lists

Frequency converter series

All = valid for FC 301 and FC 302 series

01 = valid for FC 301 only

02 = valid for FC 302 only

Changes during operation

"TRUE" means that the parameter can be changed while the frequency converter is in operation and "FALSE" means that the frequency converter must be stopped before a change can be made.

2-Set-up

'All set-ups': the parameter can be set individually in each of the 2 set-ups, i. e. one single parameter can have 2 different data values.

'1 set-up': data value will be the same in all set-ups.

| Data type | Description | Type |
|-----------|--------------------------------------|--------|
| 2 | Integer 8 | Int8 |
| 3 | Integer 16 | Int16 |
| 4 | Integer 32 | Int32 |
| 5 | Unsigned 8 | UInt8 |
| 6 | Unsigned 16 | UInt16 |
| 7 | Unsigned 32 | UInt32 |
| 9 | Visible String | VisStr |
| 33 | Normalized value 2 bytes | N2 |
| 35 | Bit sequence of 16 boolean variables | V2 |
| 54 | Time difference w/o date | TimD |

Table 4.1 Data Type

4.1.1 Conversion

The various attributes of each parameter are displayed in Factory Setting. Parameter values are transferred as whole numbers only. Conversion factors are therefore used to transfer decimals.

4-12 Motor Speed Low Limit [Hz] has a conversion factor of 0.1. To preset the minimum frequency to 10 Hz, transfer the value 100. A conversion factor of 0.1 means that the value transferred is multiplied by 0.1. The value 100 is therefore read as 10.0.

Examples:

- 0s ⇒ conversion index 0
- 0.00s ⇒ conversion index -2
- 0ms ⇒ conversion index -3
- 0.00ms ⇒ conversion index -5

| Conversion index | Conversion factor |
|------------------|-------------------|
| 100 | |
| 75 | |
| 74 | |
| 67 | |
| 6 | 1000000 |
| 5 | 100000 |
| 4 | 10000 |
| 3 | 1000 |
| 2 | 100 |
| 1 | 10 |
| 0 | 1 |
| -1 | 0.1 |
| -2 | 0.01 |
| -3 | 0.001 |
| -4 | 0.0001 |
| -5 | 0.00001 |
| -6 | 0.000001 |
| -7 | 0.0000001 |

Table 4.2 Conversion Table

4.1.2 Active/Inactive Parameters in Different Drive Control Modes

- + = active
- = not active

| 1-10 Motor Construction | AC motor | |
|---|----------|----------------|
| | U/f mode | VVC+ |
| 1-01 Motor Control Principle | | |
| 1-00 Configuration Mode | | |
| [0] Speed Open Loop | + | + |
| [1] Speed Closed Loop | - | + |
| [3] Process | + | + |
| [4] Torque Open Loop | - | + |
| [6] Surface Winder | + | + |
| [7] Ext. PID Open Loop | + | + |
| 1-03 Torque Characteristics | - | + see 1, 2, 3) |
| 1-06 Clockwise Direction | + | + |
| 1-20 Motor Power [kW] (Par. 023 = International) | + | + |
| 1-22 Motor Voltage | + | + |
| 1-23 Motor Frequency | + | + |
| 1-24 Motor Current | + | + |
| 1-25 Motor Nominal Speed | + | + |
| 1-29 Automatic Motor Adaptation (AMA) | + | + |
| 1-30 Stator Resistance (Rs) | + | + |
| 1-33 Stator Leakage Reactance (X1) | + | + |
| 1-34 Rotor Leakage Reactance (X2) | - | + see 5) |
| 1-35 Main Reactance (Xh) | + | + |
| 1-39 Motor Poles | + | + |

Table 4.3 Active/inactive Parameters

- 1) Constant torque
- 2) Variable torque
- 3) AEO
- 5) Used in flystart

| 1-10 Motor Construction | AC motor | |
|---|-------------|-------------|
| | U/f mode | VVC+ |
| 1-50 Motor Magnetisation at Zero Speed | - | + |
| 1-52 Min Speed Normal Magnetising [Hz](Par. 002 = Hz) | - | + |
| 1-55 U/f Characteristic - U | + | - |
| 1-56 U/f Characteristic - F | + | - |
| 1-58 Flystart Test Pulses Current | - | + |
| 1-59 Flystart Test Pulses Frequency | - | + |
| 1-60 Low Speed Load Compensation | - | + |
| 1-61 High Speed Load Compensation | - | + |
| 1-62 Slip Compensation | - | + see 7) |
| 1-63 Slip Compensation Time Constant | + see 8) | + |
| 1-64 Resonance Damping | + | + |
| 1-65 Resonance Damping Time Constant | + | + |
| 1-71 Start Delay | + | + |
| 1-72 Start Function | + | + |
| 1-73 Flying Start | - | + |
| 1-75 Start Speed [Hz](Par. 002 = Hz) | - | + |
| 1-76 Start Current | - | + |

Table 4.4 Active/inactive Parameters

6) Used when 1-03 Torque Characteristics is constant power

7) Not used when 1-03 Torque Characteristics = VT

8) Part of resonance damping

| 1-10 Motor Construction | AC motor | |
|---|----------|-----|
| | U/f mode | WC+ |
| 1-01 Motor Control Principle | | |
| 1-80 Function at Stop | + | + |
| 1-82 Min Speed for Function at Stop [Hz] (Par. 002 = Hz) | + | + |
| 1-90 Motor Thermal Protection | + | + |
| 1-93 Thermistor Resource | + | + |
| 2-00 DC Hold Current | + | + |
| 2-01 DC Brake Current | + | + |
| 2-02 DC Braking Time | + | + |
| 2-04 DC Brake Cut In Speed [Hz] | + | + |
| 2-10 Brake Function | + | + |
| | see 9) | |
| 2-11 Brake Resistor (ohm) | + | + |
| 2-12 Brake Power Limit (kW) | + | + |
| 2-15 Brake Check | + | + |
| | see 9) | |
| 2-16 AC brake Max. Current | - | + |
| 2-17 Over-voltage Control | + | + |
| 2-19 Over-voltage Gain | + | + |
| 2-20 Release Brake Current | + | + |
| 2-22 Activate Brake Speed [Hz] | + | + |

Table 4.5 Active/inactive Parameters

9) Not AC brake

4.1.3 0-** Operation and Display

| Par. No. # | Parameter description | Default value | 2-set-up | Change during operation | Conversion index | Type |
|--------------------------------|-----------------------------|-----------------------|-------------|-------------------------|------------------|--------|
| 0-0* Basic Settings | | | | | | |
| 0-01 | Language | [0] English | 1 set-up | TRUE | - | Uint8 |
| 0-03 | Regional Settings | [0] International | 1 set-up | FALSE | - | Uint8 |
| 0-04 | Operating State at Power-up | [0] Resume | All set-ups | TRUE | - | Uint8 |
| 0-06 | GridType | ExpressionLimit | 1 set-up | FALSE | - | Uint8 |
| 0-07 | Auto DC Braking | [1] On | 1 set-up | FALSE | - | Uint8 |
| 0-1* Set-up Operations | | | | | | |
| 0-10 | Active Set-up | [1] Set-up 1 | 1 set-up | TRUE | - | Uint8 |
| 0-11 | Programming Set-up | [9] Active Set-up | 1 set-up | TRUE | - | Uint8 |
| 0-12 | Link Setups | [20] Linked | All set-ups | FALSE | - | Uint8 |
| 0-16 | Application Selection | [0] None | 1 set-up | FALSE | - | Uint8 |
| 0-3* LCP Custom Readout | | | | | | |
| 0-30 | Custom Readout Unit | [1] % | 1 set-up | TRUE | - | Uint8 |
| 0-31 | Custom Readout Min Value | 0 CustomReadoutUnit | 1 set-up | TRUE | -2 | Int32 |
| 0-32 | Custom Readout Max Value | 100 CustomReadoutUnit | 1 set-up | TRUE | -2 | Int32 |
| 0-4* LCP Keypad | | | | | | |
| 0-40 | [Hand on] Key on LCP | [1] Enabled | All set-ups | TRUE | - | Uint8 |
| 0-42 | [Auto on] Key on LCP | [1] Enabled | All set-ups | TRUE | - | Uint8 |
| 0-44 | [Off/Reset] Key on LCP | [1] Enabled | All set-ups | TRUE | - | Uint8 |
| 0-5* Copy/Save | | | | | | |
| 0-50 | LCP Copy | [0] No copy | 1 set-up | FALSE | - | Uint8 |
| 0-51 | Set-up Copy | [0] No copy | 1 set-up | FALSE | - | Uint8 |
| 0-6* Password | | | | | | |
| 0-60 | Main Menu Password | 0 N/A | 1 set-up | TRUE | 0 | Uint16 |

4.1.4 1-** Load and Motor

4

| Par. No. # | Parameter description | Default value | 2-set-up | Change during operation | Conversion index | Type |
|---------------------------------|-------------------------------------|----------------------|-------------|-------------------------|------------------|--------|
| 1-0* General Settings | | | | | | |
| 1-00 | Configuration Mode | [0] Open Loop | All set-ups | TRUE | - | Uint8 |
| 1-01 | Motor Control Principle | [1] VVC+ | All set-ups | FALSE | - | Uint8 |
| 1-03 | Torque Characteristics | [0] Constant torque | All set-ups | FALSE | - | Uint8 |
| 1-06 | Clockwise Direction | [0] Normal | 1 set-up | FALSE | - | Uint8 |
| 1-1* Motor Selection | | | | | | |
| 1-10 | Motor Construction | [0] Asynchron | 1 set-up | FALSE | - | Uint8 |
| 1-2* Motor Data | | | | | | |
| 1-20 | Motor Power | ExpressionLimit | All set-ups | FALSE | - | Uint8 |
| 1-22 | Motor Voltage | ExpressionLimit | All set-ups | FALSE | 0 | Uint16 |
| 1-23 | Motor Frequency | ExpressionLimit | All set-ups | FALSE | 0 | Uint16 |
| 1-24 | Motor Current | ExpressionLimit | All set-ups | FALSE | -2 | Uint32 |
| 1-25 | Motor Nominal Speed | ExpressionLimit | All set-ups | FALSE | 67 | Uint16 |
| 1-29 | Automatic Motor Adaption (AMA) | [0] Off | 1 set-up | FALSE | - | Uint8 |
| 1-3* Adv. Motor Data I | | | | | | |
| 1-30 | Stator Resistance (Rs) | ExpressionLimit | All set-ups | FALSE | -3 | Uint32 |
| 1-33 | Stator Leakage Reactance (X1) | ExpressionLimit | All set-ups | FALSE | -3 | Uint32 |
| 1-35 | Main Reactance (Xh) | ExpressionLimit | All set-ups | FALSE | -2 | Uint32 |
| 1-39 | Motor Poles | 4 N/A | All set-ups | FALSE | 0 | Uint8 |
| 1-4* Adv. Motor Data II | | | | | | |
| 1-42 | Motor Cable Length | 50 m | All set-ups | FALSE | 0 | Uint8 |
| 1-43 | Motor Cable Length Feet | 164 ft | All set-ups | FALSE | 0 | Uint16 |
| 1-5* Load Indep. Setting | | | | | | |
| 1-50 | Motor Magnetisation at Zero Speed | 100 % | All set-ups | TRUE | 0 | Uint16 |
| 1-52 | Min Speed Normal Magnetising [Hz] | 1 Hz | All set-ups | TRUE | -1 | Uint16 |
| 1-55 | U/f Characteristic - U | ExpressionLimit | All set-ups | FALSE | -1 | Uint16 |
| 1-56 | U/f Characteristic - F | ExpressionLimit | All set-ups | FALSE | -1 | Uint16 |
| 1-6* Load Depen. Setting | | | | | | |
| 1-60 | Low Speed Load Compensation | 100 % | All set-ups | TRUE | 0 | Int16 |
| 1-61 | High Speed Load Compensation | 100 % | All set-ups | TRUE | 0 | Int16 |
| 1-62 | Slip Compensation | ExpressionLimit | All set-ups | TRUE | 0 | Int16 |
| 1-63 | Slip Compensation Time Constant | 0.1 s | All set-ups | TRUE | -2 | Uint16 |
| 1-64 | Resonance Dampening | 100 % | All set-ups | TRUE | 0 | Uint16 |
| 1-65 | Resonance Dampening Time Constant | 0.005 s | All set-ups | TRUE | -3 | Uint16 |
| 1-7* Start Adjustments | | | | | | |
| 1-71 | Start Delay | 0 s | All set-ups | TRUE | -1 | Uint8 |
| 1-72 | Start Function | [2] Coast/delay time | All set-ups | TRUE | - | Uint8 |
| 1-73 | Flying Start | [0] Disabled | All set-ups | TRUE | - | Uint8 |
| 1-75 | Start Speed [Hz] | ExpressionLimit | All set-ups | TRUE | -1 | Uint16 |
| 1-76 | Start Current | ExpressionLimit | All set-ups | TRUE | -2 | Uint32 |
| 1-78 | Compressor Start Max Speed [Hz] | 0 Hz | All set-ups | TRUE | -1 | Uint16 |
| 1-79 | Compressor Start Max Time to Trip | 5 s | All set-ups | TRUE | -1 | Uint8 |
| 1-8* Stop Adjustments | | | | | | |
| 1-80 | Function at Stop | [0] Coast | All set-ups | TRUE | - | Uint8 |
| 1-82 | Min Speed for Function at Stop [Hz] | 0 Hz | All set-ups | TRUE | -1 | Uint16 |
| 1-9* Motor Temperature | | | | | | |
| 1-90 | Motor Thermal Protection | [0] No protection | All set-ups | TRUE | - | Uint8 |
| 1-93 | Thermistor Source | [0] None | All set-ups | FALSE | - | Uint8 |

4.1.5 2-** Brakes

| Par. No. # | Parameter description | Default value | 2-set-up | Change during operation | Conversion index | Type |
|---------------------------------|-------------------------------|-----------------|-------------|-------------------------|------------------|--------|
| 2-0* DC-Brake | | | | | | |
| 2-00 | DC Hold/Motor Preheat Current | 50 % | All set-ups | TRUE | 0 | Uint16 |
| 2-01 | DC Brake Current | 50 % | All set-ups | TRUE | 0 | Uint16 |
| 2-02 | DC Braking Time | 10 s | All set-ups | TRUE | -1 | Uint16 |
| 2-04 | DC Brake Cut In Speed | 0 Hz | All set-ups | TRUE | -1 | Uint16 |
| 2-1* Brake Energy Funct. | | | | | | |
| 2-10 | Brake Function | [0] Off | All set-ups | FALSE | - | Uint8 |
| 2-11 | Brake Resistor (ohm) | ExpressionLimit | All set-ups | FALSE | -1 | Uint16 |
| 2-12 | Brake Power Limit (kW) | ExpressionLimit | All set-ups | TRUE | 0 | Uint32 |
| 2-16 | AC Brake, Max current | 100 % | All set-ups | TRUE | -1 | Uint16 |
| 2-17 | Over-voltage Control | [0] Disabled | All set-ups | TRUE | - | Uint8 |
| 2-19 | Over-voltage Gain | 100 % | All set-ups | TRUE | 0 | Uint16 |
| 2-2* Mechanical Brake | | | | | | |
| 2-20 | Release Brake Current | 0 A | All set-ups | TRUE | -2 | Uint32 |
| 2-22 | Activate Brake Speed [Hz] | 0 Hz | All set-ups | TRUE | -1 | Uint16 |

4.1.6 3-** Reference/Ramps

| Par. No. # | Parameter description | Default value | 2-set-up | Change during operation | Conversion index | Type |
|------------------------------|-------------------------------------|--------------------------|-------------|-------------------------|------------------|--------|
| 3-0* Reference Limits | | | | | | |
| 3-00 | Reference Range | [0] Min - Max | All set-ups | TRUE | - | Uint8 |
| 3-01 | Reference/Feedback Unit | ExpressionLimit | All set-ups | TRUE | - | Uint8 |
| 3-02 | Minimum Reference | 0 ReferenceFeedbackUnit | All set-ups | TRUE | -3 | Int32 |
| 3-03 | Maximum Reference | ExpressionLimit | All set-ups | TRUE | -3 | Int32 |
| 3-04 | Reference Function | [0] Sum | All set-ups | TRUE | - | Uint8 |
| 3-1* References | | | | | | |
| 3-10 | Preset Reference | 0 % | All set-ups | TRUE | -2 | Int16 |
| 3-11 | Jog Speed [Hz] | 5 Hz | All set-ups | TRUE | -1 | Uint16 |
| 3-12 | Catch up/slow Down Value | 0 % | All set-ups | TRUE | -2 | Int16 |
| 3-14 | Preset Relative Reference | 0 % | All set-ups | TRUE | -2 | Int16 |
| 3-15 | Reference 1 Source | [1] Analog Input 53 | All set-ups | TRUE | - | Uint8 |
| 3-16 | Reference 2 Source | [2] Analog Input 54 | All set-ups | TRUE | - | Uint8 |
| 3-17 | Reference 3 Source | [11] Local bus reference | All set-ups | TRUE | - | Uint8 |
| 3-18 | Relative Scaling Reference Resource | [0] No function | All set-ups | TRUE | - | Uint8 |
| 3-4* Ramp 1 | | | | | | |
| 3-40 | Ramp 1 Type | [0] Linear | All set-ups | TRUE | - | Uint8 |
| 3-41 | Ramp 1 Ramp Up Time | ExpressionLimit | All set-ups | TRUE | -2 | Uint32 |
| 3-42 | Ramp 1 Ramp Down Time | ExpressionLimit | All set-ups | TRUE | -2 | Uint32 |
| 3-5* Ramp 2 | | | | | | |
| 3-50 | Ramp 2 Type | [0] Linear | All set-ups | TRUE | - | Uint8 |
| 3-51 | Ramp 2 Ramp Up Time | ExpressionLimit | All set-ups | TRUE | -2 | Uint32 |
| 3-52 | Ramp 2 Ramp Down Time | ExpressionLimit | All set-ups | TRUE | -2 | Uint32 |
| 3-8* Other Ramps | | | | | | |
| 3-80 | Jog Ramp Time | ExpressionLimit | All set-ups | TRUE | -2 | Uint32 |
| 3-81 | Quick Stop Ramp Time | ExpressionLimit | 1 set-up | TRUE | -2 | Uint32 |

4.1.7 4-** Limits/Warnings

| Par. No. # | Parameter description | Default value | 2-set-up | Change during operation | Conversion index | Type |
|------------------------------|--------------------------------|-----------------------|-------------|-------------------------|------------------|--------|
| 4-1* Motor Limits | | | | | | |
| 4-10 | Motor Speed Direction | [2] Both directions | All set-ups | FALSE | - | Uint8 |
| 4-12 | Motor Speed Low Limit [Hz] | 0 Hz | All set-ups | FALSE | -1 | Uint16 |
| 4-14 | Motor Speed High Limit [Hz] | 65 Hz | All set-ups | FALSE | -1 | Uint16 |
| 4-16 | Torque Limit Motor Mode | ExpressionLimit | All set-ups | TRUE | 0 | Uint16 |
| 4-17 | Torque Limit Generator Mode | 100 % | All set-ups | TRUE | 0 | Uint16 |
| 4-18 | Current Limit | ExpressionLimit | All set-ups | TRUE | 0 | Uint16 |
| 4-19 | Max Output Frequency | 65 Hz | All set-ups | FALSE | -1 | Uint16 |
| 4-2* Limit Factors | | | | | | |
| 4-22 | Break Away Boost | [0] Off | All set-ups | FALSE | - | Uint8 |
| 4-3* Motor Fb Monitor | | | | | | |
| 4-30 | Motor Feedback Loss Function | [2] Trip | All set-ups | TRUE | - | Uint8 |
| 4-31 | Motor Feedback Speed Error | 20 Hz | All set-ups | TRUE | 0 | Uint16 |
| 4-32 | Motor Feedback Loss Timeout | 0.05 s | All set-ups | TRUE | -2 | Uint16 |
| 4-4* Adj. Warnings 2 | | | | | | |
| 4-40 | Warning Freq. Low | ExpressionLimit | All set-ups | TRUE | -1 | uint16 |
| 4-41 | Warning Freq. High | ExpressionLimit | All set-ups | TRUE | -1 | uint16 |
| 4-42 | Adjustable Temperature Warning | 0 N/A | All set-ups | TRUE | 0 | Uint8 |
| 4-5* Adj. Warnings | | | | | | |
| 4-50 | Warning Current Low | 0 A | All set-ups | TRUE | -2 | Uint32 |
| 4-51 | Warning Current High | ExpressionLimit | All set-ups | TRUE | -2 | Uint32 |
| 4-54 | Warning Reference Low | -4999 N/A | All set-ups | TRUE | -3 | Int32 |
| 4-55 | Warning Reference High | 4999 N/A | All set-ups | TRUE | -3 | Int32 |
| 4-56 | Warning Feedback Low | -4999 ProcessCtrlUnit | All set-ups | TRUE | -3 | Int32 |
| 4-57 | Warning Feedback High | 4999 ProcessCtrlUnit | All set-ups | TRUE | -3 | Int32 |
| 4-58 | Missing Motor Phase Function | [1] On | All set-ups | FALSE | - | Uint8 |
| 4-6* Speed Bypass | | | | | | |
| 4-61 | Bypass Speed From [Hz] | 0 Hz | All set-ups | TRUE | -1 | Uint16 |
| 4-63 | Bypass Speed To [Hz] | 0 Hz | All set-ups | TRUE | -1 | Uint16 |

4.1.8 5-** Digital In/Out

| Par. No. # | Parameter description | Default value | 2-set-up | Change during operation | Conversion index | Type |
|-------------------------------|-----------------------------------|-----------------------|-------------|-------------------------|------------------|--------|
| 5-0* Digital I/O mode | | | | | | |
| 5-00 | Digital I/O Mode | [0] PNP | 1 set-up | FALSE | - | Uint8 |
| 5-01 | Terminal 27 Mode | [0] Input | All set-ups | TRUE | - | Uint8 |
| 5-02 | Terminal 29 Mode | [0] Input | All set-ups | TRUE | - | Uint8 |
| 5-1* Digital Inputs | | | | | | |
| 5-10 | Terminal 18 Digital Input | [8] Start | All set-ups | TRUE | - | Uint8 |
| 5-11 | Terminal 19 Digital Input | [10] Reversing | All set-ups | TRUE | - | Uint8 |
| 5-12 | Terminal 27 Digital Input | ExpressionLimit | All set-ups | TRUE | - | Uint8 |
| 5-13 | Terminal 29 Digital Input | [14] Jog | All set-ups | TRUE | - | Uint8 |
| 5-14 | Terminal 32 Digital Input | [0] No operation | All set-ups | TRUE | - | Uint8 |
| 5-15 | Terminal 33 Digital Input | [16] Preset ref bit 0 | All set-ups | TRUE | - | Uint8 |
| 5-16 | Terminal 31 Digital Input | [0] No operation | All set-ups | TRUE | - | Uint8 |
| 5-3* Digital Outputs | | | | | | |
| 5-30 | Terminal 27 Digital Output | [0] No operation | All set-ups | TRUE | - | Uint8 |
| 5-31 | Terminal 29 Digital Output | [0] No operation | All set-ups | TRUE | - | Uint8 |
| 5-34 | On Delay, Digital Output | 0.01 s | All set-ups | TRUE | -2 | uint16 |
| 5-35 | Off Delay, Digital Output | 0.01 s | All set-ups | TRUE | -2 | uint16 |
| 5-4* Relays | | | | | | |
| 5-40 | Function Relay | ExpressionLimit | All set-ups | TRUE | - | Uint8 |
| 5-41 | On Delay, Relay | 0.01 s | All set-ups | TRUE | -2 | Uint16 |
| 5-42 | Off Delay, Relay | 0.01 s | All set-ups | TRUE | -2 | Uint16 |
| 5-5* Pulse Input | | | | | | |
| 5-50 | Term. 29 Low Frequency | 4 Hz | All set-ups | TRUE | 0 | Uint32 |
| 5-51 | Term. 29 High Frequency | 32000 Hz | All set-ups | TRUE | 0 | Uint32 |
| 5-52 | Term. 29 Low Ref./Feedb. Value | 0 N/A | All set-ups | TRUE | -3 | Int32 |
| 5-53 | Term. 29 High Ref./Feedb. Value | ExpressionLimit | All set-ups | TRUE | -3 | Int32 |
| 5-55 | Term. 33 Low Frequency | 4 Hz | All set-ups | TRUE | 0 | Uint32 |
| 5-56 | Term. 33 High Frequency | 32000 Hz | All set-ups | TRUE | 0 | Uint32 |
| 5-57 | Term. 33 Low Ref./Feedb. Value | 0 N/A | All set-ups | TRUE | -3 | Int32 |
| 5-58 | Term. 33 High Ref./Feedb. Value | ExpressionLimit | All set-ups | TRUE | -3 | Int32 |
| 5-6* Pulse Output | | | | | | |
| 5-60 | Terminal 27 Pulse Output Variable | [0] No operation | All set-ups | TRUE | - | Uint8 |
| 5-62 | Pulse Output Max Freq 27 | 5000 Hz | All set-ups | TRUE | 0 | Uint32 |
| 5-63 | Terminal 29 Pulse Output Variable | [0] No operation | All set-ups | TRUE | - | Uint8 |
| 5-65 | Pulse Output Max Freq 29 | 5000 Hz | All set-ups | TRUE | 0 | Uint32 |
| 5-7* 24V Encoder Input | | | | | | |
| 5-70 | Term 32/33 Pulses Per Revolution | 1024 N/A | All set-ups | FALSE | 0 | Uint16 |
| 5-71 | Term 32/33 Encoder Direction | [0] Clockwise | All set-ups | FALSE | - | Uint8 |
| 5-9* Bus Controlled | | | | | | |
| 5-90 | Digital & Relay Bus Control | 0 N/A | All set-ups | TRUE | 0 | Uint32 |
| 5-93 | Pulse Out 27 Bus Control | 0 % | All set-ups | TRUE | -2 | Uint16 |
| 5-94 | Pulse Out 27 Timeout Preset | 0 % | 1 set-up | TRUE | -2 | Uint16 |
| 5-95 | Pulse Out 29 Bus Control | 0 % | All set-ups | TRUE | -2 | Uint16 |
| 5-96 | Pulse Out 29 Timeout Preset | 0 % | 1 set-up | TRUE | -2 | Uint16 |

4.1.9 6-** Analog In/Out

4

| Par. No. # | Parameter description | Default value | 2-set-up | Change during operation | Conversion index | Type |
|--------------------------------------|------------------------------------|------------------|-------------|-------------------------|------------------|--------|
| 6-0* Analog I/O Mode | | | | | | |
| 6-00 | Live Zero Timeout Time | 10 s | All set-ups | TRUE | 0 | Uint8 |
| 6-01 | Live Zero Timeout Function | [0] Off | All set-ups | TRUE | - | Uint8 |
| 6-1* Analog Input 53 | | | | | | |
| 6-10 | Terminal 53 Low Voltage | 0.07 V | All set-ups | TRUE | -2 | Uint16 |
| 6-11 | Terminal 53 High Voltage | 10 V | All set-ups | TRUE | -2 | Uint16 |
| 6-12 | Terminal 53 Low Current | 4 mA | All set-ups | TRUE | -5 | Uint16 |
| 6-13 | Terminal 53 High Current | 20 mA | All set-ups | TRUE | -5 | Uint16 |
| 6-14 | Terminal 53 Low Ref./Feedb. Value | 0 N/A | All set-ups | TRUE | -3 | Int32 |
| 6-15 | Terminal 53 High Ref./Feedb. Value | ExpressionLimit | All set-ups | TRUE | -3 | Int32 |
| 6-16 | Terminal 53 Filter Time Constant | 0.01 s | All set-ups | TRUE | -2 | Uint16 |
| 6-19 | Terminal 53 mode | [1] Voltage mode | 1 set-up | TRUE | - | Uint8 |
| 6-2* Analog Input 54 | | | | | | |
| 6-20 | Terminal 54 Low Voltage | 0.07 V | All set-ups | TRUE | -2 | Uint16 |
| 6-21 | Terminal 54 High Voltage | 10 V | All set-ups | TRUE | -2 | Uint16 |
| 6-22 | Terminal 54 Low Current | 4 mA | All set-ups | TRUE | -5 | Uint16 |
| 6-23 | Terminal 54 High Current | 20 mA | All set-ups | TRUE | -5 | Uint16 |
| 6-24 | Terminal 54 Low Ref./Feedb. Value | 0 N/A | All set-ups | TRUE | -3 | Int32 |
| 6-25 | Terminal 54 High Ref./Feedb. Value | ExpressionLimit | All set-ups | TRUE | -3 | Int32 |
| 6-26 | Terminal 54 Filter Time Constant | 0.01 s | All set-ups | TRUE | -2 | Uint16 |
| 6-29 | Terminal 54 mode | [1] Voltage mode | 1 set-up | TRUE | - | Uint8 |
| 6-7* Analog/Digital Output 45 | | | | | | |
| 6-70 | Terminal 45 Mode | [0] 0-20 mA | All set-ups | TRUE | - | Uint8 |
| 6-71 | Terminal 45 Analog Output | [0] No operation | All set-ups | TRUE | - | Uint8 |
| 6-72 | Terminal 45 Digital Output | [0] No operation | All set-ups | TRUE | - | Uint8 |
| 6-73 | Terminal 45 Output Min Scale | 0 % | All set-ups | TRUE | -2 | Uint16 |
| 6-74 | Terminal 45 Output Max Scale | 100 % | All set-ups | TRUE | -2 | Uint16 |
| 6-76 | Terminal 45 Output Bus Control | 0 N/A | All set-ups | TRUE | 0 | Uint16 |
| 6-9* Analog/Digital Output 42 | | | | | | |
| 6-90 | Terminal 42 Mode | [0] 0-20 mA | All set-ups | TRUE | - | Uint8 |
| 6-91 | Terminal 42 Analog Output | [0] No operation | All set-ups | TRUE | - | Uint8 |
| 6-92 | Terminal 42 Digital Output | [0] No operation | All set-ups | TRUE | - | Uint8 |
| 6-93 | Terminal 42 Output Min Scale | 0 % | All set-ups | TRUE | -2 | Uint16 |
| 6-94 | Terminal 42 Output Max Scale | 100 % | All set-ups | TRUE | -2 | Uint16 |
| 6-96 | Terminal 42 Output Bus Control | 0 N/A | All set-ups | TRUE | 0 | Uint16 |
| 6-98 | Drive Type | 0 N/A | 1 set-up | FALSE | 0 | Uint8 |

4.1.10 7-** Controllers

| Par. No. # | Parameter description | Default value | 2-set-up | Change during operation | Conversion index | Type |
|---------------------------------|---|-----------------|-------------|-------------------------|------------------|--------|
| 7-0* Speed PID Ctrl. | | | | | | |
| 7-00 | Speed PID Feedback Source | [20] None | All set-ups | FALSE | - | Uint8 |
| 7-02 | Speed PID Proportional Gain | 0.015 N/A | All set-ups | TRUE | -3 | Uint16 |
| 7-03 | Speed PID Integral Time | 8 ms | All set-ups | TRUE | -4 | Uint32 |
| 7-04 | Speed PID Differentiation Time | 30 ms | All set-ups | TRUE | -4 | Uint16 |
| 7-05 | Speed PID Diff. Gain Limit | 5 N/A | All set-ups | TRUE | -1 | Uint16 |
| 7-06 | Speed PID Lowpass Filter Time | 10 ms | All set-ups | TRUE | -4 | Uint16 |
| 7-07 | Speed PID Feedback Gear Ratio | 1 N/A | All set-ups | FALSE | -4 | Uint32 |
| 7-08 | Speed PID Feed Forward Factor | 0 % | All set-ups | FALSE | 0 | Uint16 |
| 7-1* Torque PID Ctrl. | | | | | | |
| 7-12 | Torque PID Proportional Gain | 100 % | All set-ups | TRUE | 0 | Uint16 |
| 7-13 | Torque PID Integration Time | 0.020 s | All set-ups | TRUE | -3 | Uint16 |
| 7-2* Process Ctrl. Feedb | | | | | | |
| 7-20 | Process CL Feedback 1 Resource | [0] No function | All set-ups | TRUE | - | Uint8 |
| 7-22 | Process CL Feedback 2 Resource | [0] No function | All set-ups | TRUE | - | Uint8 |
| 7-3* Process PID Ctrl. | | | | | | |
| 7-30 | Process PID Normal/ Inverse Control | [0] Normal | All set-ups | TRUE | - | Uint8 |
| 7-31 | Process PID Anti Windup | [1] On | All set-ups | TRUE | - | Uint8 |
| 7-32 | Process PID Start Speed | 0 RPM | All set-ups | TRUE | 67 | Uint16 |
| 7-33 | Process PID Proportional Gain | 0.01 N/A | All set-ups | TRUE | -2 | Uint16 |
| 7-34 | Process PID Integral Time | 9999 s | All set-ups | TRUE | -2 | Uint32 |
| 7-35 | Process PID Differentiation Time | 0 s | All set-ups | TRUE | -2 | Uint16 |
| 7-36 | Process PID Diff. Gain Limit | 5 N/A | All set-ups | TRUE | -1 | Uint16 |
| 7-38 | Process PID Feed Forward Factor | 0 % | All set-ups | TRUE | 0 | Uint16 |
| 7-39 | On Reference Bandwidth | 5 % | All set-ups | TRUE | 0 | Uint8 |
| 7-4* Adv. Process PID I | | | | | | |
| 7-40 | Process PID I-part Reset | [0] No | All set-ups | TRUE | - | Uint8 |
| 7-41 | Process PID Output Neg. Clamp | -100 % | All set-ups | TRUE | 0 | Int16 |
| 7-42 | Process PID Output Pos. Clamp | 100 % | All set-ups | TRUE | 0 | Int16 |
| 7-43 | Process PID Gain Scale at Min. Ref. | 100 % | All set-ups | TRUE | 0 | Int16 |
| 7-44 | Process PID Gain Scale at Max. Ref. | 100 % | All set-ups | TRUE | 0 | Int16 |
| 7-45 | Process PID Feed Fwd Resource | [0] No function | All set-ups | TRUE | - | Uint8 |
| 7-46 | Process PID Feed Fwd Normal/ Inv. Ctrl. | [0] Normal | All set-ups | TRUE | - | Uint8 |
| 7-49 | Process PID Output Normal/ Inv. Ctrl. | [0] Normal | All set-ups | TRUE | - | Uint8 |
| 7-5* Adv. Process PID II | | | | | | |
| 7-50 | Process PID Extended PID | [1] Enabled | All set-ups | TRUE | - | Uint8 |
| 7-51 | Process PID Feed Fwd Gain | 1 N/A | All set-ups | TRUE | -2 | Uint16 |
| 7-52 | Process PID Feed Fwd Ramp up | 0.01 s | All set-ups | TRUE | -2 | Uint32 |
| 7-53 | Process PID Feed Fwd Ramp down | 0.01 s | All set-ups | TRUE | -2 | Uint32 |
| 7-56 | Process PID Ref. Filter Time | 0.001 s | All set-ups | TRUE | -3 | Uint16 |
| 7-57 | Process PID Fb. Filter Time | 0.001 s | All set-ups | TRUE | -3 | Uint16 |
| 7-6* Feedback Conversion | | | | | | |
| 7-60 | Feedback 1 Conversion | [0] Linear | All set-ups | TRUE | - | Uint8 |
| 7-62 | Feedback 2 Conversion | [0] Linear | All set-ups | TRUE | - | Uint8 |

4.1.11 8-** Communications and Options

4

| Par. No. # | Parameter description | Default value | 2-set-up | Change during operation | Conversion index | Type |
|---------------------------------|---------------------------|---------------------------|-------------|-------------------------|------------------|--------|
| 8-0* General Settings | | | | | | |
| 8-01 | Control Site | [0] Digital and ctrl.word | All set-ups | TRUE | - | Uint8 |
| 8-02 | Control Source | [1] FC Port | All set-ups | TRUE | - | Uint8 |
| 8-03 | Control Timeout Time | 1 s | 1 set-up | TRUE | -1 | Uint16 |
| 8-04 | Control Timeout Function | [0] Off | 1 set-up | TRUE | - | Uint8 |
| 8-1* Ctrl. Word Settings | | | | | | |
| 8-10 | Control Word Profile | [0] FC profile | All set-ups | TRUE | - | Uint8 |
| 8-3* FC Port Settings | | | | | | |
| 8-30 | Protocol | [0] FC | 1 set-up | TRUE | - | Uint8 |
| 8-31 | Address | 1 N/A | 1 set-up | TRUE | 0 | Uint8 |
| 8-32 | Baud Rate | ExpressionLimit | 1 set-up | TRUE | - | Uint8 |
| 8-33 | Parity / Stop Bits | ExpressionLimit | 1 set-up | TRUE | - | Uint8 |
| 8-35 | Minimum Response Delay | 0.01 s | 1 set-up | TRUE | -3 | Uint16 |
| 8-36 | Maximum Response Delay | ExpressionLimit | 1 set-up | TRUE | -3 | Uint16 |
| 8-37 | Maximum Inter-char delay | 0.025 s | 1 set-up | TRUE | -3 | Uint16 |
| 8-4* FC MC protocol set | | | | | | |
| 8-43 | PCD Read Configuration | ExpressionLimit | 1 set-up | TRUE | - | Uint8 |
| 8-5* Digital/Bus | | | | | | |
| 8-50 | Coasting Select | [3] Logic OR | All set-ups | TRUE | - | Uint8 |
| 8-51 | Quick Stop Select | [3] Logic OR | All set-ups | TRUE | - | Uint8 |
| 8-52 | DC Brake Select | [3] Logic OR | All set-ups | TRUE | - | Uint8 |
| 8-53 | Start Select | [3] Logic OR | All set-ups | TRUE | - | Uint8 |
| 8-54 | Reversing Select | [3] Logic OR | All set-ups | TRUE | - | Uint8 |
| 8-55 | Set-up Select | [3] Logic OR | All set-ups | TRUE | - | Uint8 |
| 8-56 | Preset Reference Select | [3] Logic OR | All set-ups | TRUE | - | Uint8 |
| 8-57 | Profidrive OFF2 Select | [3] Logic OR | All set-ups | TRUE | - | Uint8 |
| 8-58 | Profidrive OFF3 Select | [3] Logic OR | All set-ups | TRUE | - | Uint8 |
| 8-7* BACnet | | | | | | |
| 8-79 | Protocol Firmware version | ExpressionLimit | 1 set-up | FALSE | -2 | Uint16 |
| 8-8* FC Port Diagnostics | | | | | | |
| 8-80 | Bus Message Count | 0 N/A | 1 set-up | TRUE | 0 | Uint32 |
| 8-81 | Bus Error Count | 0 N/A | 1 set-up | TRUE | 0 | Uint32 |
| 8-82 | Slave Messages Rcvd | 0 N/A | 1 set-up | TRUE | 0 | Uint32 |
| 8-83 | Slave Error Count | 0 N/A | 1 set-up | TRUE | 0 | Uint32 |
| 8-84 | Slave Messages Sent | 0 N/A | 1 set-up | TRUE | 0 | Uint32 |
| 8-85 | Slave Timeout Errors | 0 N/A | 1 set-up | TRUE | 0 | Uint32 |
| 8-88 | Reset FC port Diagnostics | [0] Do not reset | 1 set-up | TRUE | - | Uint8 |

4.1.12 13-** Smart Logic Control

| Par. No. # | Parameter description | Default value | 2-set-up | Change during operation | Conversion index | Type |
|---------------------------|-----------------------|----------------------|----------|-------------------------|------------------|--------|
| 13-0* SLC Settings | | | | | | |
| 13-00 | SL Controller Mode | [0] Off | 1 set-up | TRUE | - | Uint8 |
| 13-01 | Start Event | [39] Start command | 1 set-up | TRUE | - | Uint8 |
| 13-02 | Stop Event | [40] Drive stopped | 1 set-up | TRUE | - | Uint8 |
| 13-03 | Reset SLC | [0] Do not reset SLC | 1 set-up | TRUE | - | Uint8 |
| 13-1* Comparators | | | | | | |
| 13-10 | Comparator Operand | [0] Disabled | 1 set-up | TRUE | - | Uint8 |
| 13-11 | Comparator Operator | [1] Approx.Equal (~) | 1 set-up | TRUE | - | Uint8 |
| 13-12 | Comparator Value | 0 N/A | 1 set-up | TRUE | -3 | Int32 |
| 13-2* Timers | | | | | | |
| 13-20 | SL Controller Timer | 0 s | 1 set-up | TRUE | -2 | Uint32 |
| 13-4* Logic Rules | | | | | | |
| 13-40 | Logic Rule Boolean 1 | [0] False | 1 set-up | TRUE | - | Uint8 |
| 13-41 | Logic Rule Operator 1 | [0] Disabled | 1 set-up | TRUE | - | Uint8 |
| 13-42 | Logic Rule Boolean 2 | [0] False | 1 set-up | TRUE | - | Uint8 |
| 13-43 | Logic Rule Operator 2 | [0] Disabled | 1 set-up | TRUE | - | Uint8 |
| 13-44 | Logic Rule Boolean 3 | [0] False | 1 set-up | TRUE | - | Uint8 |
| 13-5* States | | | | | | |
| 13-51 | SL Controller Event | [0] False | 1 set-up | TRUE | - | Uint8 |
| 13-52 | SL Controller Action | [0] Disabled | 1 set-up | TRUE | - | Uint8 |

4.1.13 14-** Special Functions

4

| Par. No. # | Parameter description | Default value | 2-set-up | Change during operation | Conversion index | Type |
|----------------------------------|-------------------------------------|----------------------------------|-------------|-------------------------|------------------|--------|
| 14-0* Inverter Switching | | | | | | |
| 14-01 | Switching Frequency | ExpressionLimit | All set-ups | TRUE | - | Uint8 |
| 14-03 | Overmodulation | [1] On | All set-ups | FALSE | - | Uint8 |
| 14-08 | Damping Gain Factor | 96 % | All set-ups | TRUE | 0 | Uint8 |
| 14-1* Mains On/Off | | | | | | |
| 14-10 | Mains Failure | [0] No function | All set-ups | FALSE | - | Uint8 |
| 14-11 | Mains Voltage at Mains Fault | 342 V | All set-ups | TRUE | 0 | Uint16 |
| 14-12 | Function at Mains Imbalance | [0] Trip | 1 set-up | TRUE | - | Uint8 |
| 14-15 | Kin. Backup Trip Recovery Level | 60000.000 ReferenceFeed-backUnit | All set-ups | TRUE | -3 | Uint32 |
| 14-2* Reset Functions | | | | | | |
| 14-20 | Reset Mode | [0] Manual reset | All set-ups | TRUE | - | Uint8 |
| 14-21 | Automatic Restart Time | 10 s | All set-ups | TRUE | 0 | Uint16 |
| 14-22 | Operation Mode | [0] Normal operation | 1 set-up | TRUE | - | Uint8 |
| 14-23 | Typecode Setting | 0 N/A | 1 set-up | FALSE | 0 | uint8 |
| 14-24 | Trip Delay at Current Limit | 60 s | All set-ups | TRUE | 0 | Uint8 |
| 14-25 | Trip Delay at Torque Limit | 60 s | All set-ups | TRUE | 0 | Uint8 |
| 14-27 | Action At Inverter Fault | [1] Warning | All set-ups | TRUE | - | Uint8 |
| 14-28 | Production Settings | [0] No action | 1 set-up | FALSE | - | Uint8 |
| 14-29 | Service Code | 0 N/A | 1 set-up | TRUE | 0 | Uint32 |
| 14-3* Current Limit Ctrl. | | | | | | |
| 14-30 | Current Lim Ctrl, Proportional Gain | 100 % | All set-ups | TRUE | 0 | Uint16 |
| 14-31 | Current Lim Ctrl, Integration Time | 0.020 s | All set-ups | TRUE | -3 | Uint16 |
| 14-32 | Current Lim Ctrl, Filter Time | 10 ms | All set-ups | TRUE | -4 | Uint16 |
| 14-4* Energy Optimising | | | | | | |
| 14-40 | VT Level | 66 % | All set-ups | FALSE | 0 | Uint8 |
| 14-41 | AEO Minimum Magnetisation | 66 % | All set-ups | FALSE | 0 | Uint8 |
| 14-5* Environment | | | | | | |
| 14-50 | RFI Filter | [2] Grid type | 1 set-up | FALSE | - | Uint8 |
| 14-51 | DC-Link Voltage Compensation | [1] On | All set-ups | FALSE | - | Uint8 |
| 14-52 | Fan Control | [5] Constant-on mode | 1 set-up | TRUE | - | Uint8 |
| 14-55 | Output Filter | [0] No Filter | 1 set-up | FALSE | - | Uint8 |
| 14-6* Auto Derate | | | | | | |
| 14-63 | Min Switch Frequency | [2] 2.0 kHz | 1 set-up | FALSE | - | Uint8 |

4.1.14 15-** Drive Information

| Par. No. # | Parameter description | Default value | 2-set-up | Change during operation | Conversion index | Type |
|-----------------------------------|-----------------------------|------------------|----------|-------------------------|------------------|------------|
| 15-0* Operating Data | | | | | | |
| 15-00 | Operating hours | 0 h | 1 set-up | TRUE | 74 | Uint32 |
| 15-01 | Running Hours | 0 h | 1 set-up | TRUE | 74 | Uint32 |
| 15-02 | kWh Counter | 0 kWh | 1 set-up | TRUE | 75 | Uint32 |
| 15-03 | Power Up's | 0 N/A | 1 set-up | TRUE | 0 | Uint32 |
| 15-04 | Over Temp's | 0 N/A | 1 set-up | TRUE | 0 | Uint16 |
| 15-05 | Over Volt's | 0 N/A | 1 set-up | TRUE | 0 | Uint16 |
| 15-06 | Reset kWh Counter | [0] Do not reset | 1 set-up | TRUE | - | Uint8 |
| 15-07 | Reset Running Hours Counter | [0] Do not reset | 1 set-up | TRUE | - | Uint8 |
| 15-3* Alarm Log | | | | | | |
| 15-30 | Alarm Log: Error Code | 0 N/A | 1 set-up | TRUE | 0 | Uint8 |
| 15-31 | InternalFaultReason | 0 N/A | 1 set-up | TRUE | 0 | Int16 |
| 15-4* Drive Identification | | | | | | |
| 15-40 | FC Type | 0 N/A | 1 set-up | FALSE | 0 | VisStr[7] |
| 15-41 | Power Section | 0 N/A | 1 set-up | FALSE | 0 | VisStr[20] |
| 15-42 | Voltage | 0 N/A | 1 set-up | FALSE | 0 | VisStr[20] |
| 15-43 | Software Version | 0 N/A | 1 set-up | FALSE | 0 | VisStr[20] |
| 15-44 | Ordered TypeCode | 0 N/A | 1 set-up | FALSE | 0 | VisStr[41] |
| 15-46 | Drive Ordering No | 0 N/A | 1 set-up | FALSE | 0 | VisStr[9] |
| 15-47 | Power Card Ordering No | 0 N/A | 1 set-up | FALSE | 0 | VisStr[9] |
| 15-48 | LCP Id No | 0 N/A | 1 set-up | FALSE | 0 | VisStr[21] |
| 15-49 | SW ID Control Card | 0 N/A | 1 set-up | FALSE | 0 | VisStr[21] |
| 15-50 | SW ID Power Card | 0 N/A | 1 set-up | FALSE | 0 | VisStr[21] |
| 15-51 | Drive Serial Number | 0 N/A | 1 set-up | FALSE | 0 | VisStr[13] |
| 15-53 | Power Card Serial Number | 0 N/A | 1 set-up | FALSE | 0 | VisStr[21] |
| 15-9* Parameter Info | | | | | | |
| 15-92 | Defined Parameters | 0 N/A | 1 set-up | TRUE | 0 | Uint16 |
| 15-97 | Application Type | 0 N/A | 1 set-up | TRUE | 0 | Uint32 |
| 15-98 | Drive Identification | 0 N/A | 1 set-up | FALSE | 0 | VisStr[56] |

4.1.15 16-** Data Read-outs

4

| Par. No. # | Parameter description | Default value | 2-set-up | Change during operation | Conversion index | Type |
|-------------------------------------|-----------------------|-------------------------|-------------|-------------------------|------------------|------------|
| 16-0* General Status | | | | | | |
| 16-00 | Control Word | 0 N/A | 1 set-up | TRUE | 0 | Uint16 |
| 16-01 | Reference [Unit] | 0 ReferenceFeedbackUnit | 1 set-up | TRUE | -3 | Int32 |
| 16-02 | Reference [%] | 0 % | 1 set-up | TRUE | -1 | Int16 |
| 16-03 | Status Word | 0 N/A | 1 set-up | TRUE | 0 | Uint16 |
| 16-05 | Main Actual Value [%] | 0 % | 1 set-up | TRUE | -2 | Int16 |
| 16-09 | Custom Readout | 0 CustomReadoutUnit | 1 set-up | TRUE | -2 | Int32 |
| 16-1* Motor Status | | | | | | |
| 16-10 | Power [kW] | 0 kW | 1 set-up | TRUE | -3 | Uint32 |
| 16-11 | Power [hp] | 0 hp | 1 set-up | TRUE | -3 | Uint32 |
| 16-12 | Motor Voltage | 0 V | 1 set-up | TRUE | -1 | Uint32 |
| 16-13 | Frequency | 0 Hz | 1 set-up | TRUE | -1 | Uint32 |
| 16-14 | Motor current | 0 A | 1 set-up | TRUE | -2 | Uint16 |
| 16-15 | Frequency [%] | 0 % | 1 set-up | TRUE | -1 | Uint16 |
| 16-18 | Motor Thermal | 0 % | 1 set-up | TRUE | 0 | Uint8 |
| 16-3* Drive Status | | | | | | |
| 16-30 | DC Link Voltage | 0 V | 1 set-up | TRUE | 0 | Uint32 |
| 16-33 | Brake Energy /2 min | 0 kW | All set-ups | FALSE | 0 | Uint32 |
| 16-34 | Heatsink Temp. | 0 °C | 1 set-up | TRUE | 100 | Int8 |
| 16-35 | Inverter Thermal | 0 % | 1 set-up | TRUE | 0 | Uint8 |
| 16-36 | Inv. Nom. Current | 0 A | 1 set-up | TRUE | -2 | Uint16 |
| 16-37 | Inv. Max. Current | 0 A | 1 set-up | TRUE | -2 | Uint16 |
| 16-38 | SL Controller State | 0 N/A | 1 set-up | TRUE | 0 | Uint8 |
| 16-39 | Control Card Temp. | 0 °C | All set-ups | FALSE | 100 | Uint16 |
| 16-5* Ref. & Feedb. | | | | | | |
| 16-50 | External Reference | 0 % | 1 set-up | TRUE | -1 | Int16 |
| 16-52 | Feedback[Unit] | 0 ProcessCtrlUnit | 1 set-up | TRUE | -3 | Int32 |
| 16-57 | Feedback [RPM] | 0 RPM | All set-ups | FALSE | 67 | Int32 |
| 16-6* Inputs & Outputs | | | | | | |
| 16-60 | Digital Input | 0 N/A | 1 set-up | TRUE | 0 | Uint16 |
| 16-61 | Terminal 53 Setting | [0] Current mode | 1 set-up | TRUE | - | Uint8 |
| 16-62 | Analog Input 53 | 1 N/A | 1 set-up | TRUE | -2 | Uint16 |
| 16-63 | Terminal 54 Setting | [0] Current mode | 1 set-up | TRUE | - | Uint8 |
| 16-64 | Analog Input AI54 | 1 N/A | 1 set-up | TRUE | -2 | Uint16 |
| 16-65 | Analog Output 42 [mA] | 0 mA | 1 set-up | TRUE | -2 | Uint16 |
| 16-66 | Digital Output | 0 N/A | 1 set-up | TRUE | 0 | VisStr[5] |
| 16-67 | Pulse Input 29[Hz] | 0 N/A | All set-ups | FALSE | 0 | Int32 |
| 16-68 | Pulse Input 33 [Hz] | 0 N/A | All set-ups | FALSE | 0 | Int32 |
| 16-69 | Pulse Output 27 [Hz] | 0 N/A | All set-ups | FALSE | 0 | Int32 |
| 16-70 | Pulse Output 29 [Hz] | 0 N/A | All set-ups | FALSE | 0 | Int32 |
| 16-71 | Relay Output | 0 N/A | 1 set-up | TRUE | 0 | Uint16 |
| 16-72 | Counter A | 0 N/A | 1 set-up | TRUE | 0 | Int16 |
| 16-73 | Counter B | 0 N/A | 1 set-up | TRUE | 0 | Int16 |
| 16-79 | Analog Output AO45 | 0 mA | 1 set-up | TRUE | -2 | Uint16 |
| 16-8* Fieldbus & FC Port | | | | | | |
| 16-86 | FC Port REF 1 | 0 N/A | 1 set-up | TRUE | 0 | Int16 |
| 16-9* Diagnosis Readouts | | | | | | |
| 16-90 | Alarm Word | 0 N/A | 1 set-up | TRUE | 0 | Uint32 |

| | | | | | | |
|-------|--------------------|-------|----------|------|---|--------|
| 16-91 | Alarm Word 2 | 0 N/A | 1 set-up | TRUE | 0 | Uint32 |
| 16-92 | Warning Word | 0 N/A | 1 set-up | TRUE | 0 | Uint32 |
| 16-93 | Warning Word 2 | 0 N/A | 1 set-up | TRUE | 0 | Uint32 |
| 16-94 | Ext. Status Word | 0 N/A | 1 set-up | TRUE | 0 | Uint32 |
| 16-95 | Ext. Status Word 2 | 0 N/A | 1 set-up | TRUE | 0 | Uint32 |

4.1.16 18-** Data Readouts 2

| Par. No. # | Parameter description | Default value | 2-set-up | Change during operation | Conversion index | Type |
|---------------------------|--------------------------------|---------------|-------------|-------------------------|------------------|-------|
| 18-9* PID Readouts | | | | | | |
| 18-90 | Process PID Error | 0 % | All set-ups | FALSE | -1 | Int16 |
| 18-91 | Process PID Output | 0 % | All set-ups | FALSE | -1 | Int16 |
| 18-92 | Process PID Clamped Output | 0 % | All set-ups | FALSE | -1 | Int16 |
| 18-93 | Process PID Gain Scaled Output | 0 % | All set-ups | FALSE | -1 | Int16 |

4.1.17 22-** Application Functions

| Par. No. # | Parameter description | Default value | 2-set-up | Change during operation | Conversion index | Type |
|------------------------------------|-----------------------|---------------|-------------|-------------------------|------------------|--------|
| 22-4* Sleep Mode | | | | | | |
| 22-40 | Minimum Run Time | 10 s | All set-ups | TRUE | 0 | Uint16 |
| 22-41 | Minimum Sleep Time | 10 s | All set-ups | TRUE | 0 | Uint16 |
| 22-43 | Wake-Up Speed [Hz] | 10 N/A | All set-ups | TRUE | -1 | Uint16 |
| 22-44 | Wake-Up Ref./FB Diff | 10 % | All set-ups | TRUE | 0 | Uint8 |
| 22-45 | Setpoint Boost | 0 % | All set-ups | TRUE | 0 | Int8 |
| 22-46 | Maximum Boost Time | 60 s | All set-ups | TRUE | 0 | Uint16 |
| 22-47 | Sleep Speed [Hz] | 0 N/A | All set-ups | TRUE | -1 | Uint16 |
| 22-6* Broken Belt Detection | | | | | | |
| 22-60 | Broken Belt Function | [0] Off | All set-ups | TRUE | - | Uint8 |
| 22-61 | Broken Belt Torque | 10 % | All set-ups | TRUE | 0 | Uint8 |
| 22-62 | Broken Belt Delay | 10 s | All set-ups | TRUE | 0 | Uint16 |

5 Troubleshooting

5.1 Warnings and Alarms

When the frequency converter fault circuitry detects a fault condition or a pending fault, a warning, or alarm is issued. A flashing display on the LCP indicates an alarm or warning condition and the associated number code on line 2. Sometimes a warning precedes an alarm.

5.1.1 Alarms

An alarm causes the frequency converter to trip (suspend operation). The frequency converter has three trip conditions which are displayed on line 1:

TRIP (AUTO RESTART): The frequency converter is programmed to restart automatically after the fault is removed. The number of automatic reset attempts can be continuous or limited to a programmed number of attempts. If the selected number of automatic reset attempts is exceeded, the trip condition changes to TRIP (RESET).

TRIP (RESET): Requires resetting of the frequency converter before operation after a fault is cleared. Press [Reset] to reset the frequency converter manually, or use a digital input, or a serial bus command. For FC 360 frequency converters, the stop and reset are the same key. If [Stop/Reset] is used to reset the frequency converter, [Start] must be pressed to initiate a run command in either local or remote.

TRIPLOCK (DISC> MAINS): Requires that the main AC input power to the frequency converter must be disconnected long enough for the display to go blank. The fault condition must be removed and power reapplied. Following power up, the fault indication changes to TRIP (RESET) and allow for manual, digital, or serial bus reset.

5.1.2 Warnings

During a warning, the frequency converter remains operational, although the warning flashes for as long as the condition exists. The frequency converter may, however, reduce the warning condition. For example, if the warning displayed were Torque Limit (Warning 12), the frequency converter would be reducing speed to compensate for the over-current condition. In some cases, if the condition is not corrected or worsens, an alarm condition is activated and the frequency converter output to the motor terminated. Line 1 identifies the warning in plain language and line 2 identifies the warning number.

5.1.3 Warning/Alarm Messages

The LEDs on the front of the frequency converter and a code in the display signal a warning or an alarm.

A **warning** indicates a condition that may require attention or a trend that may eventually require attention. A warning remains active until the cause is no longer present. Under some circumstances, motor operation may continue.

A **trip** is the action when an alarm has appeared. The trip removes power to the motor. It can be reset after the condition has been cleared by pressing [Reset], or through a digital input (parameter group 5–1* *Digital Inputs*). The event that caused an alarm cannot damage the frequency converter or cause a dangerous condition. Alarms must be reset to restart operation once their cause has been rectified.

The reset can be done in three ways:

- Press [Reset]
- A digital reset input
- Serial communication/optional fieldbus reset signal

NOTE

After a manual reset pressing [Reset], [Auto On] must be pressed to restart the motor.

An (X) marked in means that action occurs. A warning precedes an alarm.

A trip lock is an action when an alarm occurs which can damage the frequency converter or connected equipment. Power is removed from the motor. A trip lock can only be reset after a cycling power has cleared the condition. Once the problem has been rectified, only the alarm continues flashing until the frequency converter is reset.

| No. | Description | Warning | Alarm | Trip Lock | Cause of Problem |
|-----|-----------------------------------|---------|-------|-----------|---|
| 2 | Live zero error | X | X | | Signal on terminal 53 or 54 is less than 50% of value set in 6-10 Terminal 53 Low Voltage, 6-12 Terminal 53 Low Current, 6-20 Terminal 54 Low Voltage and 6-22 Terminal 54 Low Current. |
| 3 | No motor | X | | | No motor has been connected to the output of the frequency converter. |
| 4 | Mains phase loss ¹⁾ | X | X | X | Missing phase on supply side, or too high voltage imbalance. Check supply voltage. |
| 7 | DC over voltage ¹⁾ | X | X | | Intermediate circuit voltage exceeds limit. |
| 8 | DC under voltage ¹⁾ | X | X | | Intermediate circuit voltage drops below "under voltage" limit. |
| 9 | Inverter overloaded | X | X | | More than 100% load for too long. |
| 10 | Motor ETR over temperature | X | X | | Motor is too hot due to more than 100% load for too long. |
| 11 | Motor thermistor over temperature | X | X | | Thermistor or thermistor connection is disconnected. |
| 12 | Torque limit | X | X | | Torque exceeds value set in either 4-16 Torque Limit Motor Mode or 4-17 Torque Limit Generator Mode. |
| 13 | Over Current | X | X | X | Inverter peak current limit is exceeded. |
| 14 | Earth fault | X | X | X | Discharge from output phases to earth. |
| 16 | Short Circuit | | X | X | Short-circuit in motor or on motor terminals. |
| 17 | Control word time-out | X | X | | No communication to frequency converter. |
| 25 | Brake resistor short-circuited | X | X | X | Brake resistor is short-circuited, thus brake function is disconnected. |

| No. | Description | Warning | Alarm | Trip Lock | Cause of Problem |
|--------|--|---------|-------|-----------|--|
| 26 | Brake overload | X | X | | The power transmitted to the brake resistor over the last 120 s. exceeds the limit. Possible corrections: decrease brake energy (lower speed or longer ramp time). |
| 27 | Brake IGBT/Brake chopper short-circuited | X | X | X | Brake transistor is short-circuited, thus brake function is disconnected. |
| 28 | Brake check | X | X | | Brake resistor is not connected/working |
| 30 | U phase loss | | X | X | Motor phase U is missing. Check the phase. |
| 31 | V phase loss | | X | X | Motor phase V is missing. Check the phase. |
| 32 | W phase loss | | X | X | Motor phase W is missing. Check the phase. |
| 36 | Mains failure | X | X | | This warning/alarm is only active if the supply voltage to the frequency converter is lost and <i>14-10 Mains Failure</i> is NOT set to [0] No Function. |
| 38 | Internal fault | | X | X | Contact local Danfoss supplier. |
| 40 | Overload T27 | X | | | Check the load connected to terminal 27 or remove short-circuit connection. |
| 41 | Overload T29 | x | | | Check the load connected to terminal 29 or remove short-circuit connection. |
| 46 | Gate drive voltage fault | | X | X | |
| 47 | 24 V supply low | X | X | X | 24 V DC may be overloaded. |
| 51 | AMA check U_{nom} and I_{nom} | | X | | Wrong setting for motor voltage and/or motor current. |
| 52 | AMA low I_{nom} | | X | | Motor current is too low. Check settings. |
| 53 | AMA big motor | | X | | The motor is too large for the AMA to operate. |
| 54 | AMA small motor | | X | | The motor is too small for the AMA to operate. |
| 55 | AMA parameter range | | X | | The parameter values of the motor are outside of the acceptable range. AMA will not run. |
| 56 | AMA interrupt | | X | | The user has interrupted the AMA. |
| 57 | AMA time-out | | X | | |
| 58 | AMA internal | | X | | Contact your Danfoss supplier. |
| 59 | Current limit | X | X | | Frequency converter overload. |
| 61 | Encoder loss | X | X | | |
| 63 | Mechanical brake low | | X | | Actual motor current has not exceeded "release brake" current within "start delay" time window. |
| 65 | Control card temp | X | X | X | The cutout temperature of the control card is 80 °C. |
| 79 | Undefined | X | X | | |
| 80 | Drive initialised to default value | | X | | All parameter settings are initialised to default settings. |
| 87 | Auto DC braking | X | | | Occurs in IT mains when the frequency converter coasts and V DC is higher than 830 V. Energy on DC link is consumed by the motor. This function can be enabled/disabled in <i>0-07 Auto DC Braking</i> . |
| 95 | Broken belt | X | X | | |
| 101 | Flow/pressure info missing | | X | X | |
| nw run | Not While RUNning | | | | Parameter can only be changed when the motor is stopped. |
| Err. | A wrong password was entered | | | | Occurs when using a wrong password for changing a password-protected parameter. |

Table 5.1 Warnings and Alarms Code List

¹⁾ Mains distortions can cause these faults. Installing Danfoss Line Filter may rectify this problem.

(X) Dependent on parameter. A trip is the action when an alarm has appeared. The trip coasts the motor and can be reset by pressing [Reset] or make a reset by a digital input

(parameter group 5-1* *Digital Inputs* [1]). The original event that caused an alarm cannot damage the frequency converter or cause dangerous conditions. A trip lock is an action when an alarm occurs, which can damage the frequency converter or connected parts. A trip lock situation can only be reset by a power cycling.

| LED indication | |
|----------------|--------------|
| Warning | Yellow |
| Alarm | Flashing red |

Table 5.2 Control Terminals and Associated Parameter

The alarm words, warning words and extended status words can be read out via serial bus or optional fieldbus for diagnosis.

WARNING/ALARM 2, Live zero error

This warning or alarm only appears if programmed in 6-01 *Live Zero Timeout Function*. The signal on one of the analog inputs is less than 50% of the minimum value programmed for that input. Broken wiring or faulty device sending the signal can cause this condition.

Troubleshooting

- Check connections on all the analog input terminals. Control card terminals 53 and 54 for signals, terminal 55 common.
- Check that the frequency converter programming and switch settings match the analog signal type.
- Perform Input Terminal Signal Test.

WARNING/ALARM 4, Mains phase loss

A phase is missing on the supply side, or the mains voltage imbalance is too high. This message also appears for a fault in the input rectifier on the frequency converter. Options are programmed at 14-12 *Function at Mains Imbalance*.

Troubleshooting

Check the supply voltage and supply currents to the frequency converter.

WARNING/ALARM 7, DC overvoltage

If the intermediate circuit voltage exceeds the limit, the frequency converter trips after a time.

Troubleshooting

- Extend the ramp time
- Change the ramp type

WARNING/ALARM 8, DC under voltage

If the intermediate circuit voltage (DC link) drops below the under voltage limit, the frequency converter trips after a fixed time delay. The time delay varies with unit size.

Troubleshooting

- Check that the supply voltage matches the frequency converter voltage.
- Perform input voltage test.

Perform soft charge circuit test.

WARNING/ALARM 9, Inverter overload

The frequency converter is about to cut out because of an overload (too high current for too long). The counter for electronic, thermal inverter protection issues a warning at 90% and trips at 100%, while giving an alarm. The frequency converter *cannot* be reset until the counter is below 0%.

The fault is that the frequency converter has run with more than 100% overload for too long.

Troubleshooting

- Compare the output current shown on the LCP with the frequency converter rated current.
- Compare the output current shown on the LCP with measured motor current.
- Display the Thermal Drive Load on the LCP and monitor the value. When running above the frequency converter continuous current rating, the counter increases. When running below the frequency converter continuous current rating, the counter decreases.

WARNING/ALARM 10, Motor overload temperature

According to the electronic thermal protection (ETR), the motor is too hot. Select whether the frequency converter issues a warning or an alarm when the counter reaches 100% in 1-90 *Motor Thermal Protection*. The fault occurs when the motor runs with more than 100% overload for too long.

Troubleshooting

- Check for motor overheating.
- Check if the motor is mechanically overloaded
- Check that the motor current set in 1-24 *Motor Current* is correct.
- Ensure that Motor data in parameters 1-20 to 1-25 are set correctly.
- Running AMA in 1-29 *Automatic Motor Adaptation (AMA)* tunes the frequency converter to the motor more accurately and reduces thermal loading.

WARNING/ALARM 11, Motor thermistor over temp

Check whether the thermistor is disconnected. Select whether the frequency converter issues a warning or an alarm in 1-90 *Motor Thermal Protection*.

Troubleshooting

- Check for motor overheating.
- Check if the motor is mechanically overloaded.
- When using terminal 53 or 54, check that the thermistor is connected correctly between either terminal 53 or 54 (analog voltage input) and terminal 50 (+10 V supply). Also check that the terminal switch for 53 or 54 is set for voltage.

Check *1-93 Thermistor Source* selects terminal 53 or 54.

When using digital inputs 18 or 19, check that the thermistor is connected correctly between either terminal 18 or 19 (digital input PNP only) and terminal 50. Check *1-93 Thermistor Source* selects terminal 18 or 19.

WARNING/ALARM 13, Over current

The inverter peak current limit (approximately 200% of the rated current) is exceeded. The warning lasts about 5 s, then the frequency converter trips and issues an alarm. Shock loading or fast acceleration with high inertia loads can cause this fault.

Troubleshooting:

- Remove power and check if the motor shaft can be turned.
- Check that the motor size matches the frequency converter.
- Check parameters 1-20 to 1-25 for correct motor data.

ALARM 14, Earth (ground) fault

There is current from the output phases to earth, either in the cable between the frequency converter and the motor or in the motor itself.

Troubleshooting:

- Remove power to the frequency converter and repair the earth fault.
- Check for earth faults in the motor by measuring the resistance to ground of the motor leads and the motor with a megohmmeter.

ALARM 16, Short circuit

There is short-circuiting in the motor or motor wiring.

Remove power to the frequency converter and repair the short circuit.

WARNING/ALARM 17, Control word timeout

There is no communication to the frequency converter. The warning is only active when *8-04 Control Word Timeout Function* is NOT set to OFF.

If *8-04 Control Word Timeout Function* is set to *Stop* and *Trip*, a warning appears and the frequency converter ramps down until it trips, while giving an alarm. *8-03 Control Timeout Time* could possibly be increased.

Troubleshooting:

- Check connections on the serial communication cable.
- Increase *8-03 Control Word Timeout Time*
- Check the operation of the communication equipment.
- Verify a proper installation based on EMC requirements.

ALARM 30, Motor phase U missing

Motor phase U between the frequency converter and the motor is missing.

Remove power from the frequency converter and check motor phase U.

ALARM 31, Motor phase V missing

Motor phase V between the frequency converter and the motor is missing.

Remove power from the frequency converter and check motor phase V.

ALARM 32, Motor phase W missing

Motor phase W between the frequency converter and the motor is missing.

Remove power from the frequency converter and check motor phase W.

ALARM 38, Internal fault

When an internal fault occurs, a code number defined in *Table 5.3* is displayed.

Troubleshooting

- Cycle power
- Check that the option is properly installed
- Check for loose or missing wiring

It may be necessary to contact your Danfoss supplier or service department. Note the code number for further troubleshooting directions.

| No. | Text |
|-----------|---|
| 0 | Serial port cannot be initialised. Contact your Danfoss supplier or Danfoss Service Department. |
| 256-258 | Power EEPROM data is defective or too old. Replace power card. |
| 512-519 | Internal fault. Contact your Danfoss supplier or Danfoss Service Department. |
| 783 | Parameter value outside of min/max limits |
| 1024-1284 | Internal fault. Contact your Danfoss supplier or the Danfoss Service Department. |
| 1300 | Option SW in slot B is too old |
| 1316 | Option SW in slot B is not supported (not allowed) |
| 1379-2819 | Internal fault. Contact your Danfoss supplier or Danfoss Service Department. |
| 2561 | Replace control card |
| 2820 | LCP stack overflow |
| 2821 | Serial port overflow |
| 3072-5122 | Parameter value is outside its limits |
| 5124 | Option in slot B: Hardware incompatible with control board hardware |
| 5376-6231 | Internal fault. Contact your Danfoss supplier or Danfoss Service Department. |

Table 5.3 Internal Fault Codes

WARNING 47, 24 V supply low

The 24 V DC is measured on the control card.

ALARM 51, AMA check U_{nom} and I_{nom}

The settings for motor voltage, motor current and motor power are wrong. Check the settings in parameters 1-20 to 1-25.

ALARM 52, AMA low I_{nom}

The motor current is too low. Check the setting in *4-18 Current Limit*.

ALARM 53, AMA motor too big

The motor is too big for the AMA to operate.

ALARM 54, AMA motor too small

The motor is too small for the AMA to operate.

ALARM 55, AMA parameter out of range

The parameter values of the motor are outside of the acceptable range. AMA does not run.

56 ALARM, AMA interrupted by user

The user has interrupted the AMA.

ALARM 57, AMA internal fault

Try to restart AMA again. Repeated restarts can over heat the motor.

ALARM 58, Internal fault

Contact your Danfoss supplier.

WARNING 59, Current limit

The current is higher than the value in *4-18 Current Limit*. Ensure that Motor data in parameters 1-20 to 1-25 are set correctly. Possibly increase the current limit. Be sure that the system can operate safely at a higher limit.

WARNING 60, External interlock

A digital input signal is indicating a fault condition external to the frequency converter. An external interlock has commanded the frequency converter to trip. Clear the external fault condition. To resume normal operation, apply 24 V DC to the terminal programmed for external interlock. Reset the frequency converter.

ALARM 79, Illegal power section configuration

The scaling card is the incorrect part number or not installed. Also MK102 connector on the power card could not be installed.

ALARM 80, Drive initialised to default value

Parameter settings are initialised to default settings after a manual reset. Reset the unit to clear the alarm.

ALARM 95, Broken belt

Torque is below the torque level set for no load, indicating a broken belt. *22-60 Broken Belt Function* is set for alarm. Troubleshoot the system and reset the frequency converter after the fault has been cleared.

Index

A

- Abbreviations..... 3
- Adjustable Warnings, 4-5*..... 35
- Advanced Process PID Ctrl., 7-4*..... 54
- Alarm Log, 15-3*..... 73
- AMA..... 101, 102
- Analog
 - Inputs..... 4, 101
 - Signal..... 101
- Automatic Motor Adaption (AMA)..... 22

B

- Brake**
 - Energy Funct..... 27
 - Power..... 5
- Break-away Torque..... 4
- Broken**
 - Belt Detection..... 80
 - Belt Torque..... 80
- Bus Controlled..... 46

C

- Catch Up..... 38
- Circuitry..... 98
- Coasting..... 4
- Comparators, 13-1*..... 62
- Control**
 - Cables..... 9
 - Card..... 101
 - Terminal..... 101
- Copy/Save, 0-5*..... 20
- Ctrl. Word Settings, 8-1*..... 57
- Current**
 - Limit Control, 14-3*..... 71
 - Rating..... 101

D

- Data Readouts, 16-**..... 75

DC

- Brake Current..... 27
- Brake Cut In Speed..... 27
- Braking Time..... 27

- Default Settings..... 81
- Definitions..... 4
- Digital**
 - Input..... 102
 - Input Mode..... 37
 - Inputs..... 37
- Digital/Bus, 8-5*..... 58

- Drive**
 - Identification..... 73
 - Status, 16-3*..... 76

E

- EMC**..... 102
- Energy Optimising, 14-4*..... 71
- Environment, 14-5*..... 72
- ETR..... 76
- Ext. Process PID Ctrl., 7-5*..... 55

F

- FC**
 - MC Protocol Set, 8-4*..... 58
 - Port Diagnostics, 8-8*..... 60
 - Port Settings, 8-3*..... 57
- Fieldbus & FC Port, 16-8*..... 78
- Freeze Output..... 4

G

- General**
 - Settings, 8-0*..... 57
 - Status, 16-0*..... 75

I

- Input**
 - Signal..... 103
 - Terminals..... 101
- Inputs And Outputs..... 76
- Inverter Switching, 14-0*..... 68

J

- Jog..... 4

L

- LCP**
 - LCP..... 4, 5, 98
 - Custom Readout, 0-3*..... 18
 - Keypad, 0-4*..... 20
- LED..... 99, 101
- Live Zero..... 47
- Load Compensations..... 21
- Local Reference..... 17
- Logic Rules, 13-4*..... 63

M

- Main**
 - Menu..... 15
 - Reactance..... 22, 23

| | | |
|--|----------|--|
| Mains | | |
| On/Off, 14-1* | 68 | |
| Supply | 6 | |
| Mechanical Brake | 28 | |
| Menu Key | 11 | |
| Minimum Sleep Time | 79 | |
| Missing Motor Phase Function | 36 | |
| Motor | | |
| Control Principle | 21 | |
| Current | 22, 103 | |
| Data | 101, 103 | |
| Limits, 4-1* | 34 | |
| Magnetisation At Zero Speed | 23 | |
| Poles | 23 | |
| Power | 103 | |
| Speed Direction | 34 | |
| Status | 75 | |
| Voltage | 22 | |
| N | | |
| Navigation Keys And Indicator Lights (LEDs) | 11 | |
| Nominal Motor Speed | 22 | |
| NPN | 37 | |
| Numeric Display | 11 | |
| O | | |
| Operating | | |
| Data, 15-0* | 73 | |
| Mode | 17 | |
| Operation Keys And Indicator Lights (LEDs) | 11 | |
| Operation/Display, 0-** | 17 | |
| Output | | |
| Output | 98 | |
| Current | 101 | |
| Over-current | 98 | |
| P | | |
| Password, 0-6* | 20 | |
| Phase Loss | 101 | |
| PNP | 37 | |
| Potentiometer Reference | 10 | |
| Preset Reference | 30 | |
| Process | | |
| Ctrl. Feedb., 7-2* | 53 | |
| PID Ctrl., 7-3* | 54 | |
| Programming | 101 | |
| Protection Mode | 7 | |
| Pulse | | |
| Input, 5-5* | 44 | |
| Outputs, 5-6* | 44 | |
| Start/Stop | 10 | |
| Q | | |
| Quick Menu | 13 | |
| R | | |
| Rated Motor Speed | 4 | |
| RCD | 5 | |
| Ref. & Feedb. | 76 | |
| References, 3-1* | 30 | |
| Relay Outputs | 39 | |
| Relays | 41 | |
| Reset | 101, 103 | |
| S | | |
| Safety Precautions | 6 | |
| Screened/armoured | 9 | |
| Serial | | |
| Bus | 98, 101 | |
| Communication | 4 | |
| Set-up Operations, 0-1* | 17 | |
| Short Circuit | 102 | |
| Sleep | | |
| Mode | 79 | |
| Speed [Hz] | 80 | |
| Speed | | |
| PID Ctrl. | 52 | |
| Up/Down | 10 | |
| Start Delay | 24 | |
| Start/Stop | 9 | |
| States, 13-5* | 65 | |
| Stator | | |
| Leakage Reactance | 22, 23 | |
| Resistance | 23 | |
| Status Menu | 15 | |
| Symbols | 3 | |
| Synchronous Motor Speed | 4 | |

T

Terminal

- 42 Mode..... 50
- 45 Mode..... 48
- 53 Filter Time Constant..... 48
- 53 High Current..... 47
- 53 High Ref./Feedb. Value..... 47
- 53 High Voltage..... 47
- 53 Low Current..... 47
- 53 Low Ref./Feedb. Value..... 47
- 53 Low Voltage..... 47
- 53 Mode..... 48
- 54 Filter Time Constant..... 48
- 54 High Current..... 48
- 54 High Ref./Feedb. Value..... 48
- 54 High Voltage..... 48
- 54 Low Current..... 48
- 54 Low Ref./Feedb. Value..... 48
- 54 Low Voltage..... 48
- 54 Mode..... 48

- Thermal Load**..... 23, 76

- Thermistor**..... 6

- Timers, 13-2***..... 63

- Torque PI Control, 7-1***..... 53

Trip

- Condition..... 98
- Lock..... 99, 101
- Reset..... 70

V

Voltage

- Imbalance..... 101
- Reference Via A Potentiometer..... 10

- VCplus**..... 6

W

Warning

- Current High..... 36
- Current Low..... 35

- Warnings And Alarms**..... 100



www.danfoss.com/drives

Danfoss can accept no responsibility for possible errors in catalogues, brochures and other printed material. Danfoss reserves the right to alter its products without notice. This also applies to products already on order provided that such alterations can be made without subsequential changes being necessary in specifications already agreed. All trademarks in this material are property of the respective companies. Danfoss and the Danfoss logotype are trademarks of Danfoss A/S. All rights reserved.

