



VLT®  
HVAC Basic Drive



## Quick Guide

VLT® HVAC Basic Drive  
Cascade Controller

## Contents

<b>1 Quick Guide</b>	<b>2</b>
1.1 Safety	2
1.1.1 Warnings	2
1.1.2 Safety Instructions	2
1.2 Introduction	2
1.2.1 Available Literature	2
1.2.2 IT Mains	2
1.2.3 Avoid Unintended Start	3
1.2.4 Disposal Instruction	3
1.3 Installation	3
1.3.1 Before Starting Repair Work	3
1.3.2 Side-by-Side Installation	3
1.3.3 Mechanical Dimensions	4
1.3.4 Electrical Installation in General	4
1.3.5 Connecting to Mains and Motor	6
1.3.6 Fuses	7
1.3.7 EMC-Correct Electrical Installation	8
1.3.8 Control Terminals	10
1.3.9 Electrical Overview	11
1.4 Programming	12
1.4.1 Programming with the Local Control Panel (LCP)	12
1.4.2 The Start-up Wizard for Open Loop Applications	13
1.5 Cascade Controller	20
1.5.1 System Status and Operation	20
1.5.2 Start/Stop Conditions	21
1.6 Parameter Overview	22
1.7 Warnings and Alarms	27
1.8.1 Mains Supply 3x380-480 V AC	30
1.8.2 EMC Test Results	32
1.9 Special Conditions	35
1.9.1 Derating for Ambient Temperature and Switching Frequency	35
1.9.2 Derating for Low Air Pressure	35

# 1 Quick Guide

## 1.1 Safety

### 1.1.1 Warnings

#### **⚠ WARNING**

##### High Voltage Warning

The voltage of the frequency converter is dangerous whenever it is connected to mains. Incorrect installation of the motor or frequency converter may cause damage to the equipment, serious injury or death. Consequently, it is essential to comply with the instructions in this manual as well as local and national rules and safety regulations.

#### **⚠ WARNING**

##### Electrical Hazard

Touching the electrical parts may be fatal - even after the equipment has been disconnected from mains. Also make sure that other voltage inputs have been disconnected (linkage of DC intermediate circuit). Be aware that there may be high voltage on the DC link even when the LEDs are turned off. Before touching any potentially live parts of the frequency converter, wait at least as stated in the table below:

Voltage [V]	Power range [kW]	Minimum waiting time [min]
3x400	0.37-7.5	4
3x400	11-90	15

## CAUTION

##### Leakage Current:

The earth leakage current from the frequency converter exceeds 3.5 mA. According to IEC 61800-5-1 a reinforced Protective Earth connection must be ensured by means of a min. 10 mm<sup>2</sup> Cu or an additional PE wire - with the same cable cross section as the Mains wiring - must be terminated separately.

##### Residual Current Device:

This product can cause a DC current in the protective conductor. Where a residual current device (RCD) is used for extra protection, only an RCD of Type B (time delayed) shall be used on the supply side of this product. See also Danfoss Application Note on RCD, MN90GXYY.

Protective earthing of the frequency converter and the use of RCDs must always follow national and local regulations.

##### Motor Thermal Protection:

Motor overload protection is possible by setting *1-90 Motor Thermal Protection* to the value *Electronic Thermal Relay (ETR)* trip.

#### **⚠ WARNING**

##### Installation at high altitudes

For altitudes above 2 km, please contact Danfoss regarding PELV.

### 1.1.2 Safety Instructions

- Make sure the frequency converter is properly connected to earth.
- Do not remove mains connections, motor connections or other power connections while the frequency converter is connected to power.
- Protect users against supply voltage.
- Protect the motor against overloading according to national and local regulations.
- The earth leakage current exceeds 3.5 mA.
- The [Off reset] key is not a safety switch. It does not disconnect the frequency converter from mains.

## 1.2 Introduction

### 1.2.1 Available Literature

This Quick Guide contains the basic information necessary for installing and running the frequency converter. If more information is needed, literature can be found on the enclosed cd or downloaded from:

<http://www.danfoss.com/Products/Literature/Technical+Documentation.htm>

### 1.2.2 IT Mains

#### **⚠ CAUTION**

##### IT Mains

Installation on isolated mains source, i.e. IT mains.

Max. supply voltage allowed when connected to mains: 440 V (3x380-480 V units).

On 380-480 V IP20 0,37-22 kW, open the RFI switch by removing the screw on the side of the frequency converter when at IT grid.

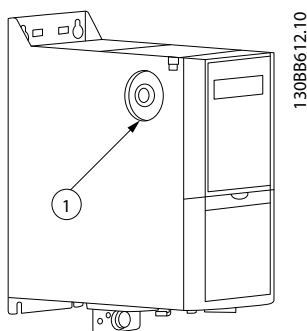

Illustration 1.1 IP20 0,37-22 kW 380-480 V.  
1: EMC screw

On all units, set 14-50 RFI filter to Off when operating in IT mains.

**CAUTION**

If reinserted, only use M3x12 screw.

1.2.3 Avoid Unintended Start

While the frequency converter is connected to mains, the motor can be started/stopped using digital commands, bus commands, references or via the LCP.

- Disconnect the frequency converter from mains whenever personal safety considerations make it necessary to avoid unintended start of any motors.
- To avoid unintended start, always press [Off reset] before changing parameters.

1.2.4 Disposal Instruction



Equipment containing electrical components must not be disposed of together with domestic waste. It must be separately collected with electrical and electronic waste according to local and currently valid legislation.

1.3 Installation

1.3.1 Before Starting Repair Work

1. Disconnect FC 111 from mains (and external DC supply, if present.)
2. Wait as stated in the table below for discharge of the DC-link:

Voltage [V]	Power range [kW]	Minimum waiting time [min]
3x400	0.37-7.5	4
3x400	11-90	15

3. Remove motor cable

1.3.2 Side-by-Side Installation

The frequency converter can be mounted side-by-side and requires the clearance above and below for cooling.

Frame	IP class	Power 3x380-480 V	Clearance above/below [mm/inch]
H1	IP20	0.37-1.5 kW/ 0.5-2 Hp	100/4
H2	IP20	2.2-4 kW/ 3-5.4 Hp	100/4
H3	IP20	5.5-7.5 kW/ 7.5-10 Hp	100/4
H4	IP20	11-15 kW/ 15-20 Hp	100/4
H5	IP20	18.5-22 kW/ 25-30 Hp	100/4
H6	IP20	30-45 kW/ 40-60 Hp	200/7.9
H7	IP20	55-75 kW/ 100-120 Hp	200/7.9
H8	IP20	90 kW/ 125 Hp	225/8.9

**NOTE**

With IP21/Nema Type1 option kit mounted, a distance of 50 mm between the units is required.

### 1.3.3 Mechanical Dimensions

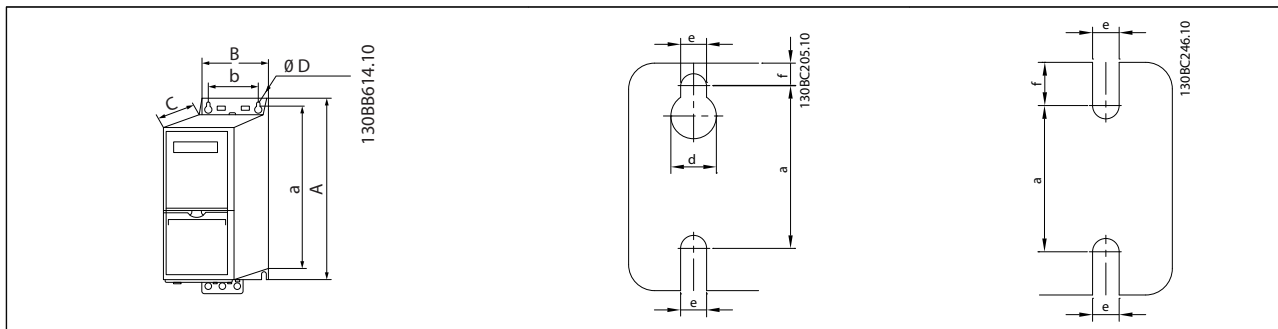

Frame	IP class	Power	Height [mm/inch]			Width [mm/inch]		Depth [mm/inch]	Hole [mm]
			A	A incl. Decoupling plate	A	B	b		
		<b>3x380-480 V</b>							
H1	IP20	0.37-1.5 kW/ 0.5-2 Hp	195/7.7	273/10.7	183/7.2	75/3	56/2.2	168/6.6	4.5
H2	IP20	2.2-4 kW/ 3-5.4 Hp	227/8.4	303/11.9	212/8.3	90/3.5	65/2.6	190/7.5	5.5
H3	IP20	5.5-7.5 kW/ 7.5-10 Hp	255/10	329/13	240/9.4	100/3.9	74/2.9	206/8.1	5.5
H4	IP20	11-15 kW/ 15-20 Hp	296/11.7	359/14.1	275/10.8	135/5.3	105/4.1	241/9.5	7
H5	IP20	18.5-22 kW/ 25-30 Hp	334/13.1	402/15.8	314/12.4	150/5.9	120/4.7	255/10	7
H6	IP20	30-45 kW/ 40-60 Hp	518/20.4	595/23.4 635/25	495/19.5	239/31.5	200/7.9	242/9.5	8.5
H7	IP20	55-75 kW/ 100-120 Hp	550/21.7	630/24.8 690/27.2	521/20.5	313/12.3	270/10.6	335/13.2	8.5
H8	IP20	90 kW/ 120 Hp	660/26	800/31.5	631/24.8	375/14.8	330/13	335/13.2	8.5

Table 1.1 Mechanical Dimensions

### 1.3.4 Electrical Installation in General

All cabling must comply with national and local regulations on cable cross-sections and ambient temperature. Copper conductors required, (75°C) recommended.

Power [kW]			Torque [Nm]					
Frame	IP class	3x380-480	Line	Motor	DC connection	Control terminals	Earth	Relay
H1	IP20	0.37-1.5	1.4	0.8	0.8	0.5	0.8	0.5
H2	IP20	2.2-4	1.4	0.8	0.8	0.5	0.8	0.5
H3	IP20	5.5-7.5	1.4	0.8	0.8	0.5	0.8	0.5
H4	IP20	11-15	1.2	1.2	1.2	0.5	0.8	0.5
H5	IP20	18.5-22	1.2	1.2	1.2	0.5	0.8	0.5
H6	IP20	30-45	4.5	4.5	-	0.5	3	0.5
H7	IP20	55	10	10	-	0.5	3	0.5
H7	IP20	75	14	14	-	0.5	3	0.5
H8	IP20	90	14 <sup>1</sup>	14 <sup>1</sup>	-	0.5	3	0.5
H8	IP20	90	24 <sup>2</sup>	24 <sup>2</sup>	-	0.5	3	0.5

<sup>1</sup> Cable dimensions  $\leq 95 \text{ mm}^2$

<sup>2</sup> Cable dimensions  $> 95 \text{ mm}^2$

### 1.3.5 Connecting to Mains and Motor

The frequency converter is designed to operate all standard three-phased asynchronous motors. For maximum cross-section on wires please see *1.8.1 Mains Supply 3x380-480 V AC*.

- Use a shielded/armored motor cable to comply with EMC emission specifications, and connect this cable to both the decoupling plate and the motor metal.
  - Keep motor cable as short as possible to reduce the noise level and leakage currents.
  - For further details on mounting of the decoupling plate, please see instruction MI02QXYY
  - Also see *EMC-Correct Installation* in the Design Guide, MG18CXYY.
1. Mount the earth wires to earth terminal.
  2. Connect motor to terminals U, V and W.
  3. Mount mains supply to terminals L1, L2 and L3 and tighten.

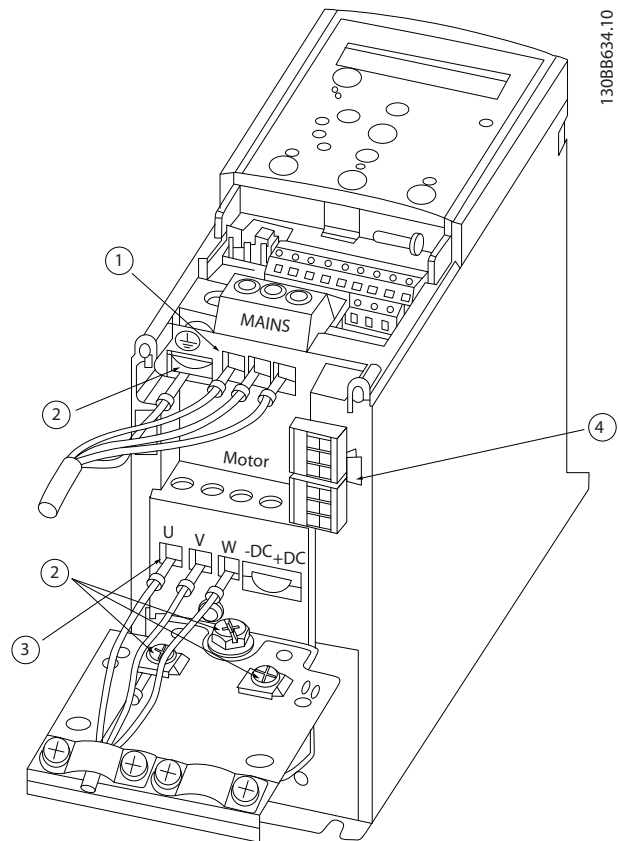
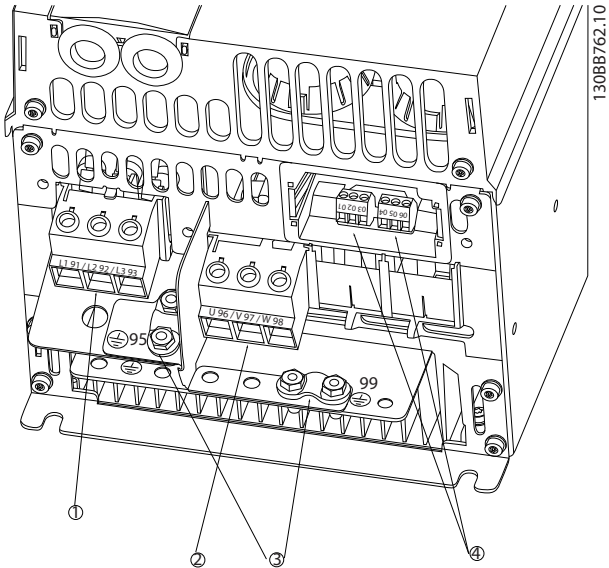

Illustration 1.2 IP20 380-480 V 0.37-22 kW.

1	Line
2	Earth
3	Motor
4	Relays



IP20 380-480 V 30-45 kW



1	Line
2	Motor
3	Earth
4	Relays

IP20 380-480 V 90 kW

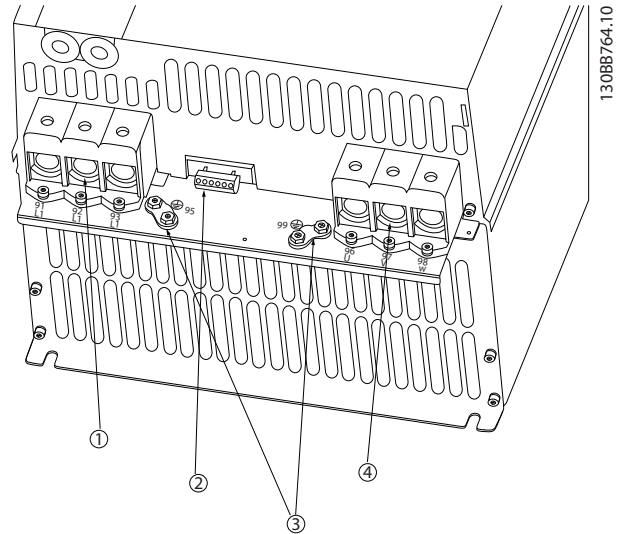

1	Line
2	Relays
3	Earth
4	Motor

IP20 380-480 V 55-75 kW

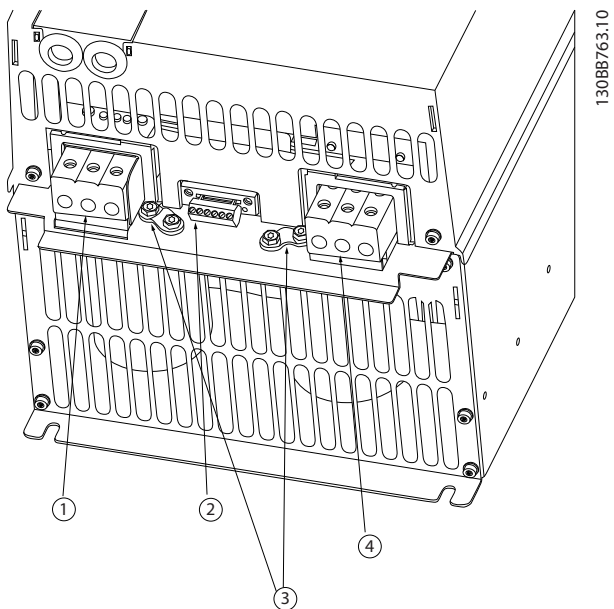

1	Line
2	Relays
3	Earth
4	Motor

### 1.3.6 Fuses

#### Branch circuit protection

In order to protect the installation against electrical and fire hazard, all branch circuits in an installation, switch gear, machines etc., must be short-circuit and overcurrent protected according to national/international regulations.

#### Short circuit protection

Danfoss recommends using the fuses mentioned in the following tables to protect service personnel or other equipment in case of an internal failure in the unit or short-circuit on DC-link. The frequency converter provides full short circuit protection in case of a short-circuit on the motor.

#### Overcurrent protection

Provide overload protection to avoid overheating of the cables in the installation. Overcurrent protection must always be carried out according to national regulations. Fuses must be designed for protection in a circuit capable of supplying a maximum of 100,000  $A_{rms}$  (symmetrical), 480 V maximum.



**Non UL compliance**

If UL/cUL is not to be complied with, use the fuses mentioned in *Table 1.2*, which will ensure compliance with IEC 61800-5-1:

In case of malfunction, not following the fuse recommendation may result in damage to the frequency converter.

UL					Non UL
	Bussmann	Bussmann	Bussmann	Bussmann	Max. Fuse
Power [kW]	Type RK5	Type RK1	Type J	Type T	Type gG
<b>3x380-480 V</b>					
0.37	FRS-R-10	KTS-R10	JKS-10	JJS-10	10
0.75	FRS-R-10	KTS-R10	JKS-10	JJS-10	10
1.5	FRS-R-10	KTS-R10	JKS-10	JJS-10	10
2.2	FRS-R-15	KTS-R15	JKS-15	JJS-15	16
3	FRS-R-15	KTS-R15	JKS-15	JJS-15	16
4	FRS-R-15	KTS-R15	JKS-15	JJS-15	16
5.5	FRS-R-25	KTS-R25	JKS-25	JJS-25	25
7.5	FRS-R-25	KTS-R25	JKS-25	JJS-25	25
11	FRS-R-50	KTS-R50	JKS-50	JJS-50	50
15	FRS-R-50	KTS-R50	JKS-50	JJS-50	50
18.5	FRS-R-80	KTS-R80	JKS-80	JJS-80	65
22	FRS-R-80	KTS-R80	JKS-80	JJS-80	65
30	FRS-R-80	KTS-R80	JKS-R80	JJS-R80	80
37	FRS-R-100	KTS-R100	JKS-R100	JJS-R100	100
45	FRS-R-125	KTS-R125	JKS-R125	JJS-R125	125
55	FRS-R-150	KTS-R150	JKS-R150	JJS-R150	150
75	FRS-R-200	KTS-R200	JKS-R200	JJS-R200	200
90	FRS-R-250	KTS-R250	JKS-R250	JJS-R250	250

**Table 1.2 Recommended fuses**

**1.3.7 EMC-Correct Electrical Installation**

General points to be observed to ensure EMC-correct electrical installation.

- Use only screened/armoured motor cables and screened/armoured control cables.
- Connect the screen to earth at both ends.
- Avoid installation with twisted screen ends (pigtailed), since this ruins the screening effect at high frequencies. Use the cable clamps provided instead.
- It is important to ensure good electrical contact from the installation plate through the installation screws to the metal cabinet of the frequency converter.
- Use starwashers and galvanically conductive installation plates.
- Do not use unscreened/unarmoured motor cables in the installation cabinets.

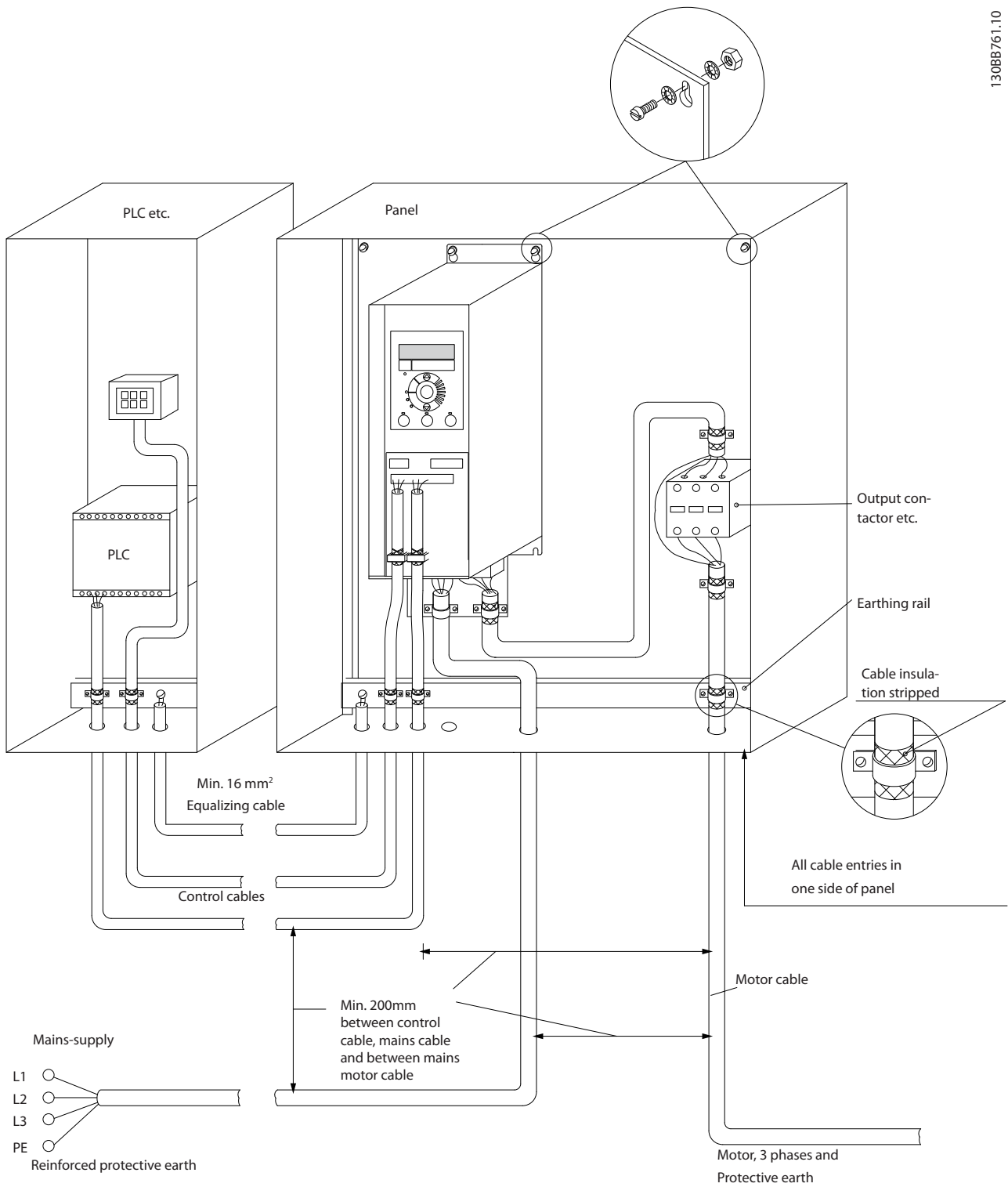

Illustration 1.3 EMC-correct Electrical Installation

For North America use metal conduits instead of shielded cables.

### 1.3.8 Control Terminals

IP20 380-480 V 0.37-22 kW:

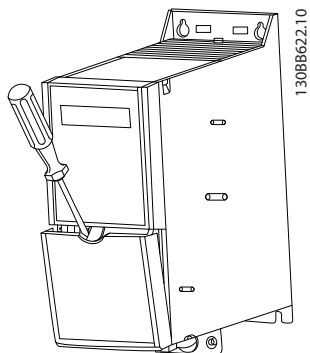
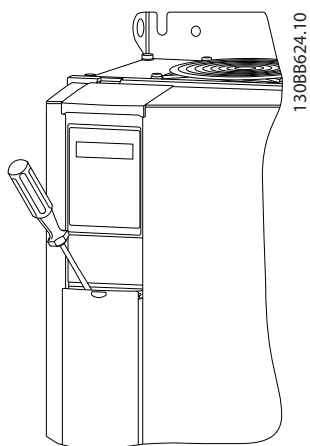

Illustration 1.4 Location of Control Terminals

1. Place a screwdriver behind the terminal cover to activate snap.
2. Tilt the screwdriver outwards to open the cover.

IP20 380-480 V 30-90 kW:



1. Place a screwdriver behind the terminal cover to activate snap.
2. Tilt the screwdriver outwards to open the cover.

Digital input 18, 19 and 27 mode is set in 5-00 Digital Input Mode (PNP is default value) and digital input 29 mode is set in 5-03 Digital Input 29 Mode (PNP is default value).

#### Control terminals:

Illustration 1.5 shows all control terminals of the frequency converter. Applying Start (term. 18), connection between terminal 12-27 and an analog reference (term. 53 or 54 and 55) make the frequency converter run.

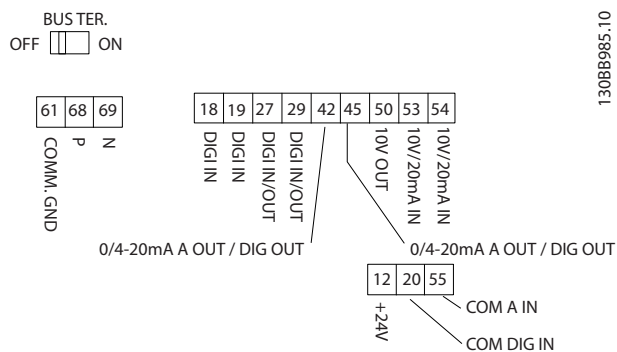
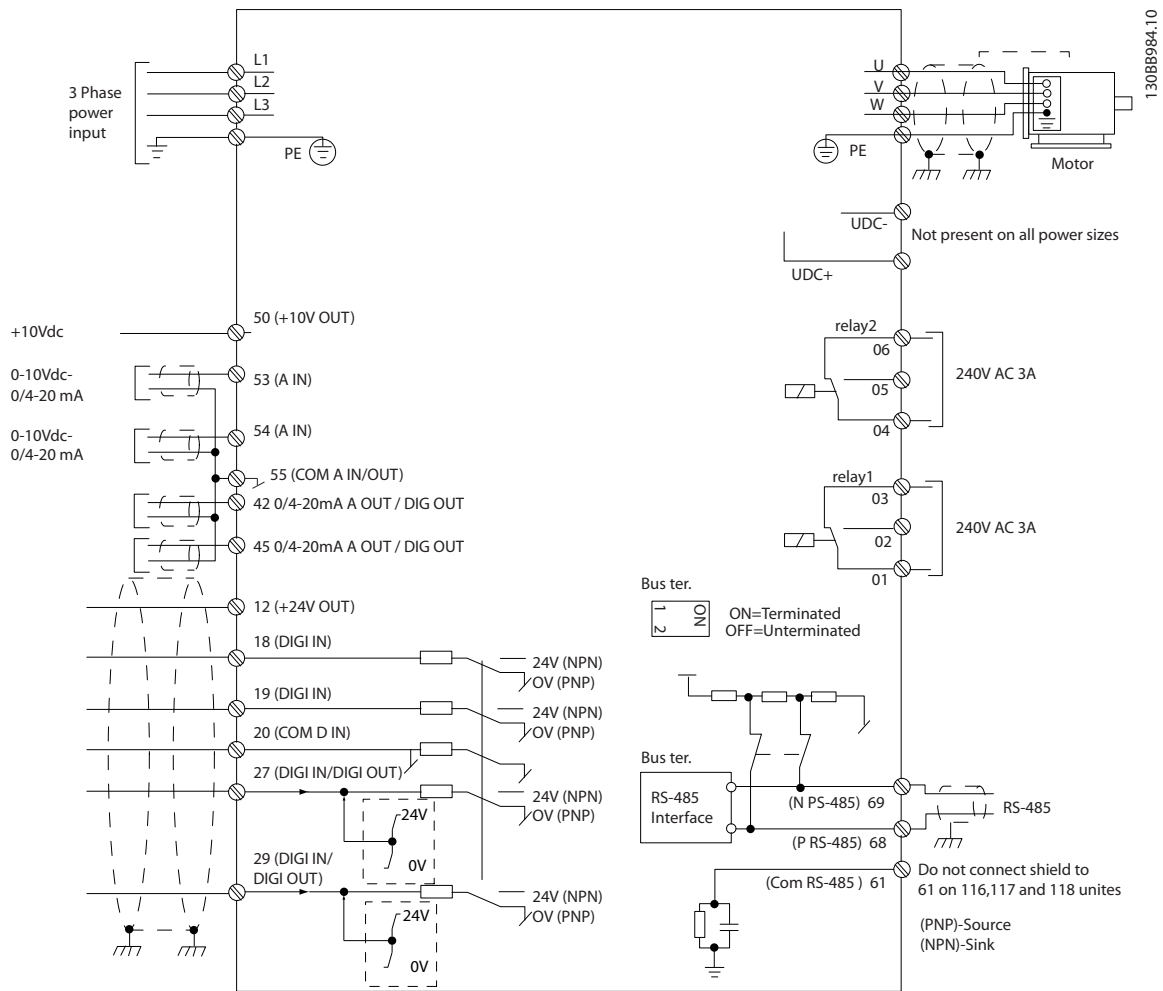

Illustration 1.5 Control Terminals

1.3.9 Electrical Overview



**NOTE**

There is no access to UDC- and UDC+ on the following units:  
 IP20 380-480 V 30-90 kW

## 1.4 Programming

### 1.4.1 Programming with the Local Control Panel (LCP)

#### NOTE

The frequency converter can also be programmed from a PC via RS-485 com-port by installing the MCT 10 Set-up Software. This software can either be ordered using code number 130B1000 or downloaded from the Danfoss Web site: [www.danfoss.com/BusinessAreas/DrivesSolutions/softwaredownload](http://www.danfoss.com/BusinessAreas/DrivesSolutions/softwaredownload)

The following instructions are valid for the FC 101 LCP. The LCP is divided into four functional sections.

- A. Alphanumeric display
- B. Menu key
- C. Navigation keys and indicator lights (LEDs)
- D. Operation keys and indicator lights (LEDs)

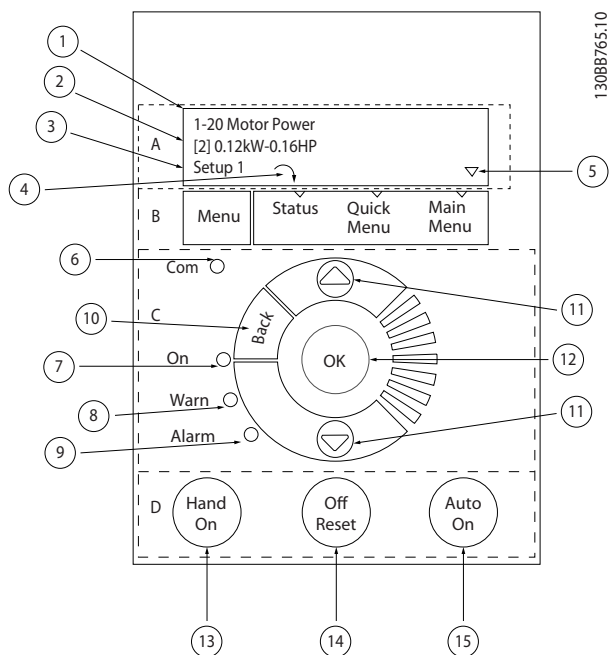

#### A. Alpha Numeric Display

The LCD-display is back-lit with 2 alpha-numeric lines. All data is displayed on the LCP.

Information can be read from the display.

1	Parameter number and name.
2	Parameter value.
3	Set-up number shows the active set-up and the edit set-up. If the same set-up acts as both active and edit set-up, only that set-up number is shown (factory setting). When active and edit set-up differ, both numbers are shown in the display (Setup 12). The number flashing, indicates the edit set-up.
4	Motor direction is shown to the bottom left of the display – indicated by a small arrow pointing either clockwise or counterclockwise.
5	The triangle indicates if the LCP is in status, quick menu or main menu.

#### B. Menu Key

Use the menu key to select between status, quick menu or main menu.

#### C. Navigation keys and indicator lights (LEDs)

6	Com led: Flashes when bus communication is communicating.
7	Green LED/On: Control section is working.
8	Yellow LED/Warn.: Indicates a warning.
9	Flashing Red LED/Alarm: Indicates an alarm.
10	[Back]: For moving to the previous step or layer in the navigation structure
11	Arrows [▲] [▼]: For maneuvering between parameter groups, parameters and within parameters. Can also be used for setting local reference.
12	[OK]: For selecting a parameter and for accepting changes to parameter settings

#### D. Operation keys and indicator lights (LEDs)

13	[Hand On]: Starts the motor and enables control of the frequency converter via the LCP. <b>NOTE</b> Terminal 27 Digital Input (5-12 Terminal 27 Digital Input) has coast inverse as default setting. This means that [Hand On] will not start the motor if there is no 24 V to terminal 27. Connect terminal 12 to terminal 27.
14	[Off/Reset]: Stops the motor (off). If in alarm mode the alarm will be reset.
15	[Auto On]: frequency converter is controlled either via control terminals or serial communication.

**At power-up**

At the first power-up the user is asked to choose preferred language. Once selected this screen will never be shown again in the following powerups, but language can still be changed in *0-01 Language*.

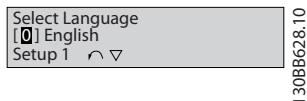

**1.4.2 The Start-up Wizard for Open Loop Applications**

The built-in “wizard” menu guides the installer through the setup of the frequency converter in a clear and structured manner to setup an open loop application. An open loop application is here an application with a start signal, analog reference (voltage or current) and optionally also relay signals (but no feed back signal from the process applied).

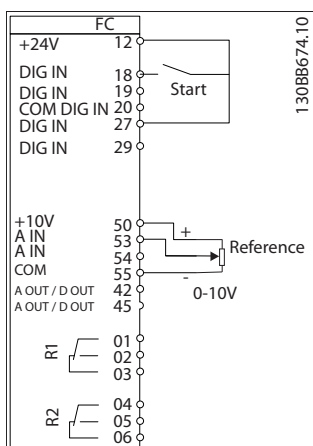

The wizard will initially be shown after power up until any parameter has been changed. The wizard can always be accessed again through the quick menu. Press [OK] to start the wizard. If [Back] is pressed, the FC 111 will return to the status screen.

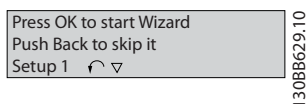

At power up the user is asked to choose the preferred language.

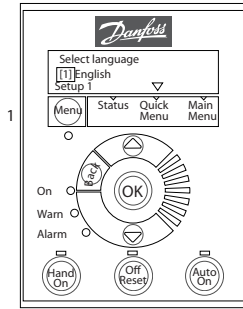

Power Up Screen



The next screen will be the Wizard screen.

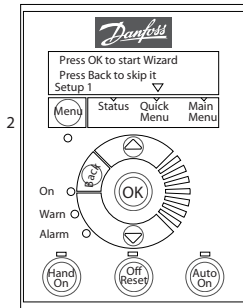

Wizard Screen

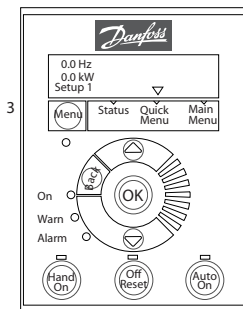

Status Screen

The Wizard can always be reentered via the Quick Menu!

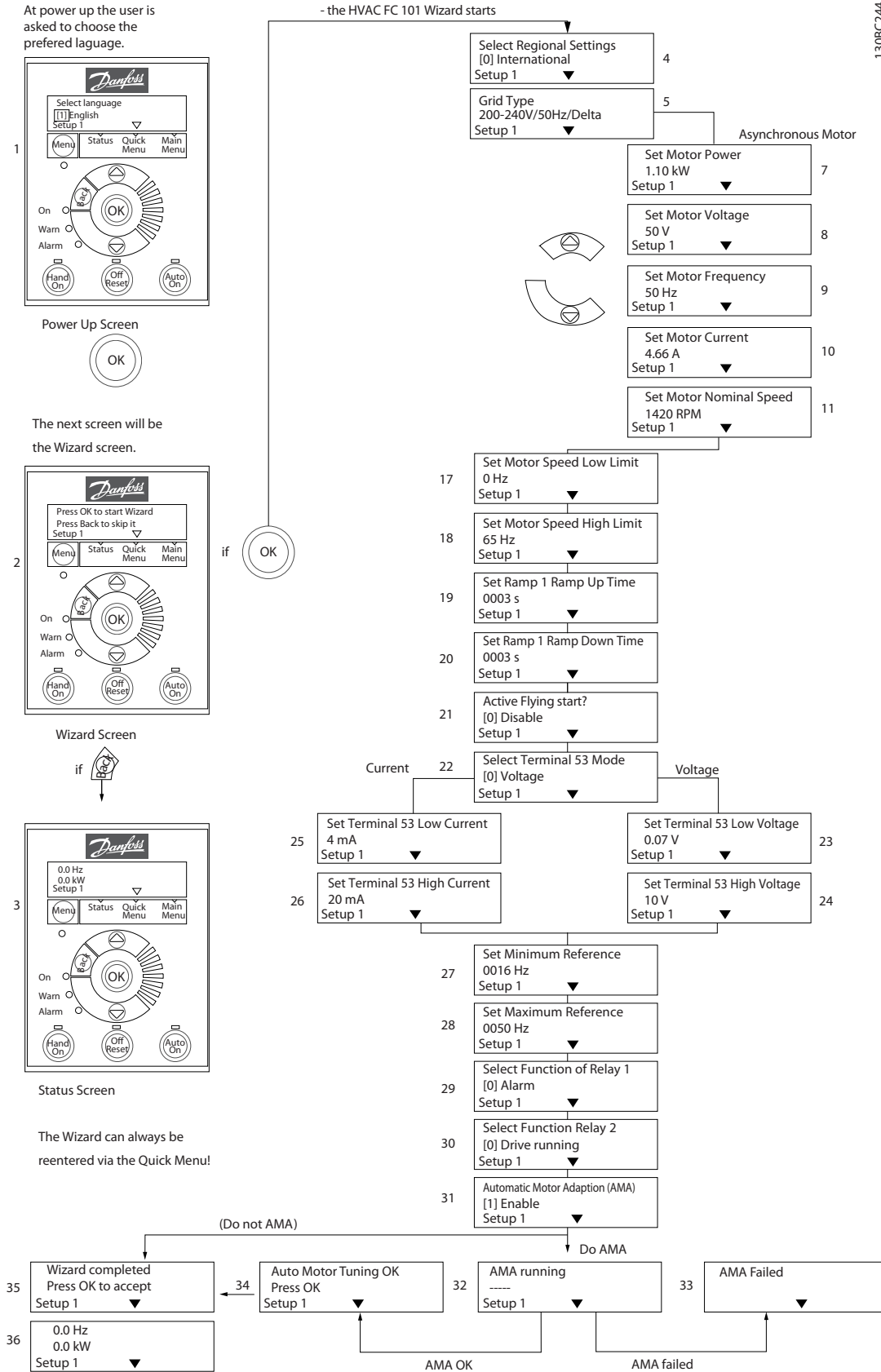

130BC244.10



The FC 111 Start-up Wizard for Open Loop Applications

No & Name	Range	Default	Function
0-03 Regional Settings	[0] International [1] US	0	
0-06 GridType	[0] 200-240 V/50 Hz/IT-grid [1] 200-240 V/50 Hz/Delta [2] 200-240 V/50 Hz [10] 380-440 V/50 Hz/IT-grid [11] 380-440 V/50 Hz/Delta [12] 380-440 V/50 Hz [20] 440-480 V/50 Hz/IT-grid [21] 440-480 V/50 Hz/Delta [22] 440-480 V/50 Hz [30] 525-600 V/50 Hz/IT-grid [31] 525-600 V/50 Hz/Delta [32] 525-600 V/50 Hz [100] 200-240 V/60 Hz/IT-grid [101] 200-240 V/60 Hz/Delta [102] 200-240 V/60 Hz [110] 380-440 V/60 Hz/IT-grid [111] 380-440 V/60 Hz/Delta [112] 380-440 V/60 Hz [120] 440-480 V/60 Hz/IT-grid [121] 440-480 V/60 Hz/Delta [122] 440-480 V/60 Hz [130] 525-600 V/60 Hz/IT-grid [131] 525-600 V/60 Hz/Delta [132] 525-600 V/60 Hz	Size related	Select operating mode for restart upon reconnection of the frequency converter to mains voltage after power down
1-20 Motor Power	0.12-110 kW/0.16-150 hp	Size related	Enter motor power from nameplate data
1-22 Motor Voltage	50.0-1000.0 V	Size related	Enter motor voltage from nameplate data
1-23 Motor Frequency	20.0-400.0 Hz	Size related	Enter motor frequency from nameplate data
1-24 Motor Current	0.01-10000.00 A	Size related	Enter motor current from nameplate data
1-25 Motor Nominal Speed	100.0-9999.0 RPM	Size related	Enter motor nominal speed from nameplate data
4-12 Motor Speed Low Limit [Hz]	0.0-400 Hz	0 Hz	Enter the minimum limit for low speed
4-14 Motor Speed High Limit [Hz]	0.0-400 Hz	65 Hz	Enter the maximum limit for high speed
3-41 Ramp 1 Ramp Up Time	0.05-3600.0 s	Size related	Ramp up time from 0 to rated <i>1-23 Motor Frequency</i>
3-42 Ramp 1 Ramp Down Time	0.05-3600.0 s	Size related	Ramp down time from rated <i>1-23 Motor Frequency</i> to 0
1-73 Flying Start	[0] Disabled [1] Enabled	0	Select Enable to enable the frequency converter to catch a spinning motor i.e. fan applications
6-19 Terminal 53 mode	[0] Current [1] Voltage	1	Select if terminal 53 is used for current- or voltage input
6-10 Terminal 53 Low Voltage	0-10 V	0.07 V	Enter the voltage that corresponds to the low reference value
6-11 Terminal 53 High Voltage	0-10 V	10 V	Enter the voltage that corresponds to the high reference value
6-12 Terminal 53 Low Current	0-20 mA	4	Enter the current that corresponds to the low reference value
6-13 Terminal 53 High Current	0-20 mA	20	Enter the current that corresponds to the high reference value
3-02 Minimum Reference	-4999-4999	0	The minimum reference is the lowest value obtainable by summing all references

1

No & Name	Range	Default	Function
3-03 Maximum Reference	-4999-4999	50	The maximum reference is the lowest obtainable by summing all references
5-40 Function Relay [0] Function relay	See 5-40 Function Relay	Alarm	Select the function to control output relay 1
5-40 Function Relay [1] Function relay	See 5-40 Function Relay	Drive running	Select the function to control output relay 2
1-29 Automatic Motor Adaption (AMA)	See 1-29 Automatic Motor Adaption (AMA)	Off	Performing an optimizes motor performance

Closed Loop Set-up Wizard

130BC245.10

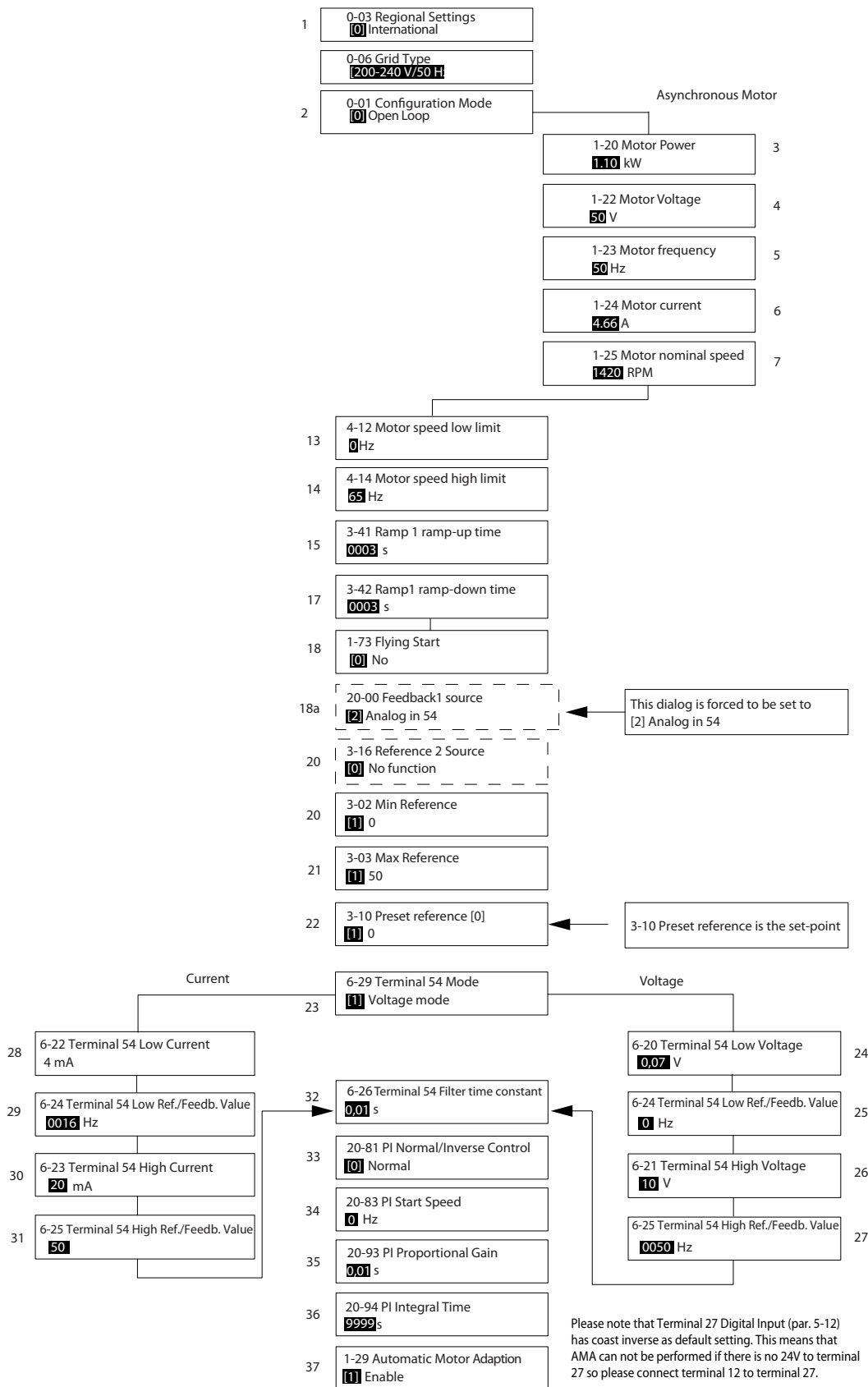

## Closed Loop Set-up Wizard

No & Name	Range	Default	Function
0-03 Regional Settings	[0] International [1] US	0	
0-06 GridType	[0]-[[132] please see start-up wizard for open loop application	Size selected	Select operating mode for restart upon reconnection of the frequency converter to mains voltage after power down
1-20 Motor Power	0.09-110 kW	Size related	Enter motor power from nameplate data
1-22 Motor Voltage	50.0-1000.0 V	Size related	Enter motor voltage from nameplate data
1-23 Motor Frequency	20.0-400.0 Hz	Size related	Enter motor frequency from nameplate data
1-24 Motor Current	0.01-10000.00 A	Size related	Enter motor current from nameplate data
1-25 Motor Nominal Speed	100.0-9999.0 RPM	Size related	Enter motor nominal speed from nameplate data
4-12 Motor Speed Low Limit [Hz]	0.0-400 Hz	0.0 Hz	Enter the minimum limit for low speed
4-14 Motor Speed High Limit [Hz]	0.1-400 Hz	65 Hz	Enter the maximum limit for high speed
3-41 Ramp 1 Ramp Up Time	0.05-3600.0 s	Size related	Ramp up time from 0 to rated motor frequency, 1-23 Motor Frequency
3-42 Ramp 1 Ramp Down Time	0.05-3600.0 s	Size related	Ramp down time from rated motor frequency, 1-23 Motor Frequency to 0
1-73 Flying Start	[0] Disabled [1] Enabled	0	Select Enable to enable the frequency converter to catch a spinning motor
3-02 Minimum Reference	-4999-4999	0	The minimum reference is the lowest value obtainable by summing all references
3-03 Maximum Reference	-4999-4999	50	The maximum reference is the highest value obtainable by summing all references
3-10 Preset Reference	-100-100%	0	Enter the set point
6-29 Terminal 54 mode	[0] Current [1] Voltage	1	Select if terminal 54 is used for current- or voltage input
6-20 Terminal 54 Low Voltage	0-10 V	0.07 V	Enter the voltage that corresponds to the low reference value
6-21 Terminal 54 High Voltage	0-10 V	10 V	Enter the voltage that corresponds to the low high reference value
6-22 Terminal 54 Low Current	0-20 mA	4	Enter the current that corresponds to the high reference value
6-23 Terminal 54 High Current	0-20 mA	20	Enter the current that corresponds to the high reference value
6-24 Terminal 54 Low Ref./Feedb. Value	-4999-4999	0	Enter the feedback value that corresponds to the voltage or current set in 6-20 Terminal 54 Low Voltage/6-22 Terminal 54 Low Current
6-25 Terminal 54 High Ref./Feedb. Value	-4999-4999	50	Enter the feedback value that corresponds to the voltage or current set in 6-21 Terminal 54 High Voltage/6-23 Terminal 54 High Current
6-26 Terminal 54 Filter Time Constant	0-10 s	0.01	Enter the filter time constant
1-23 Motor Frequency	[0] Normal [1] Inverse	0	Select <i>Normal</i> [0] to set the process control to increase the output speed when the process error is positive. Select <i>Inverse</i> [1] to reduce the output speed.
20-83 PI Start Speed [Hz]	0-200 Hz	0	Enter the motor speed to be attained as a start signal for commencement of PI control
20-93 PI Proportional Gain	0-10	0.01	Enter the process controller proportional gain. Quick control is obtained at high amplification. However if amplification is too great, the process may become unstable

No & Name	Range	Default	Function
20-94 PI Integral Time	0.1-999.0 s	999.0 s	Enter the process controller integral time. Obtain quick control through a short integral time, though if the integral time is too short, the process becomes unstable. An excessively long integral time disables the integral action.
1-29 Automatic Motor Adaption (AMA)		Off	Performing an optimizes motor performance

**Motor Set-up**

The Quick Menu Motor Set-up guides through the needed motor parameters.

No & Name	Range	Default	Function
0-03 Regional Settings	[0] International [1] US	0	
0-06 GridType	[0]-[132] please see start-up wizard for open loop application	Size selected	Select operating mode for restart upon reconnection of the frequency converter to mains voltage after power down
1-20 Motor Power	0.12-110 kW/ 0.16-150 Hp	Size related	Enter motor power from nameplate data
1-22 Motor Voltage	50.0-1000.0 V	Size related	Enter motor voltage from nameplate data
1-23 Motor Frequency	20.0-400.0 Hz	Size related	Enter motor frequency from nameplate data
1-24 Motor Current	0.01-10000.00 A	Size related	Enter motor current from nameplate data
1-25 Motor Nominal Speed	100.0-9999.0 RPM	Size related	Enter motor nominal speed from nameplate data
4-12 Motor Speed Low Limit [Hz]	0.0-400 Hz	0.0 Hz	Enter the minimum limit for low speed
4-14 Motor Speed High Limit [Hz]	0-400 Hz	65	Enter the maximum limit for high speed
3-41 Ramp 1 Ramp Up Time	0.05-3600.0 s	Size related	Ramp up time from 0 to rated motor frequency <i>1-23 Motor Frequency</i>

No & Name	Range	Default	Function
3-42 Ramp 1 Ramp Down Time	0.05-3600.0 s	Size related	Ramp down time from rated motor frequency <i>1-23 Motor Frequency to 0</i>
1-73 Flying Start	[0] Disabled [1] Enabled	0	Select [1] Enable to enable the frequency converter to catch a spinning motor

**Changes Made**

Changes Made lists all parameters changed since factory setting. Only the changed parameters in current edit-setup are listed in changes made.

If the parameters value is changed back to factory setting's value from another different value, the parameter will NOT be listed in Changes Made.

1. Press [Menu] key to enter the Quick Menu until indicator in display is placed above Quick Menu.
2. Press [▲] [▼] to select either FC 111 wizard, closed loop setup, motor setup or changes made, then press [OK].
3. Press [▲] [▼] to browse through the parameters in the Quick Menu.
4. Press [OK] to select a parameter.
5. Press [▲] [▼] to change the value of a parameter setting.
6. Press [OK] to accept the change.
7. Press either [Back] twice to enter "Status", or press [Menu] once to enter "Main Menu".

The Main Menu accesses all parameters.

1. Press [Menu] key until indicator in display is placed above "Main Menu".
2. Press [▲] [▼] to browse through the parameter groups.
3. Press [OK] to select a parameter group.
4. Press [▲] [▼] to browse through the parameters in the specific group.

5. Press [OK] to select the parameter.
6. Press [▲] [▼] to set/change the parameter value.

## 1.5 Cascade Controller

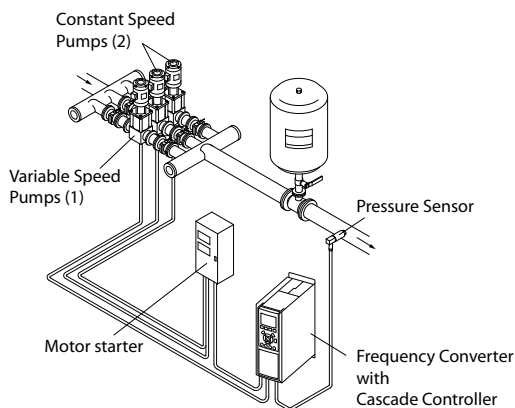

130BA362.10

The Cascade Controller is used for pump applications where a certain pressure (“head”) or level needs to be maintained over a wide dynamic range. Running a large pump at variable speed over a wide for range is not an ideal solution because of low pump efficiency and because there is a practical limit of about 25% rated full load speed for running a pump.

In the Cascade Controller the frequency converter controls a variable speed motor as the variable speed pump (lead) and can stage up to two additional constant speed pumps on and off. By varying the speed of the initial pump, variable speed control of the entire system is provided. This maintains constant pressure while eliminating pressure surges, resulting in reduced system stress and quieter operation in pumping systems.

### Fixed Lead Pump

The motors must be of equal size. The Cascade Controller allows the frequency converter to control up to 5 equal size pumps using the drives two built-in relays and terminal 27, 29 (DI/DO). When the variable pump (lead) is connected directly to the frequency converter, the other 4 pumps are controlled by the two built-in relays and terminal 27, 29 (DI/DO). Lead pump alternation can not be chosen when lead pump is fixed.

### Lead Pump Alternation

The motors must be of equal size. This function makes it possible to cycle the frequency converter between the pumps in the system (when 25-57 *Relays per Pump* =1, maximum pump is 4. When 25-57 *Relays per Pump* =2, maximum pump is 3). In this operation the run time between pumps is equalized reducing the required pump maintenance and increasing reliability and lifetime of the system. The alternation of the lead pump can take place at a command signal or at staging (adding lag pump).

The command can be a manual alternation or an alternation event signal. If the alternation event is selected, the lead pump alternation takes place every time the event occurs. Selections include whenever an alternation timer expires, when the lead pump goes into sleep mode. Staging is determined by the actual system load.

25-55 *Alternate if Load <= 50%* = 1, if load >50% Alternation will not happen. If load <=50% Alternation will happen. When 25-55 *Alternate if Load <= 50%* = 0, Alternation will happen no matter with Load. Total pump capacity is determined as lead pump plus lag speed pumps capacities.

### Bandwidth Management

In cascade control systems, to avoid frequent switching of fixed speed pumps, the desired system pressure is kept within a bandwidth rather than at a constant level. The Staging Bandwidth provides the required bandwidth for operation. When a large and quick change in system pressure occurs, the Override Bandwidth overrides the Staging Bandwidth to prevent immediate response to a short duration pressure change. An Override Bandwidth Timer can be programmed to prevent staging until the system pressure has stabilized and normal control established.

When the Cascade Controller is enabled and running normally and the frequency converter issues a trip alarm, the system head is maintained by staging and destaging fixed speed pumps. To prevent frequent staging and destaging and minimize pressure fluxuations, a wider Fixed Speed Bandwidth is used instead of the Staging bandwidth.

### 1.5.1 System Status and Operation

Only when lead pump is working, the frequency converter can go into sleep mode. When the Cascade Controller is enabled, the operation status for each pump and the Cascade Controller is displayed by 25-81, *Pump Status* and 25-80, *Cascade Status* on the LCP. Cascade Controller information displayed includes:

- Pumps Status, is a read out of the status for the relays assigned to each pump. The display shows pumps that are disabled, off, running on the frequency converter or running on the mains/ motor starter.
- Cascade Status, is a read out of the status for the Cascade Controller. The display shows the Cascade Controller is disabled, all pumps are running off, fixed speed pumps are being staged/de-staged and lead pump alternation is occurring.

### 1.5.2 Start/Stop Conditions

Commands assigned to digital inputs. See *Digital Inputs*, parameter group 5-1\*.

	Variable speed pump (lead)	Fixed speed pumps (lag)
Start (SYSTEM START/STOP)	Ramps up (if stopped and there is a demand)	Staging (if stopped and there is a demand)
Lead Pump Start	Ramps up if SYSTEM START is active	Not affected
Coast (EMERGENCY STOP)	Coast to stop	Cut out (correspond relays, terminal 27/29 and 42/45)
External Interlock	Coast to stop	Cut out (built-in relays are de-energized)

Function of buttons on LCP:

	Variable speed pump (lead)	Fixed speed pumps (lag)
[Hand On]	Ramps up (if stopped by a normal stop command) or stays in operation if already running	Destaging (if running)
[Off]	Ramps down	Destaging
[Auto On]	Starts and stops according to commands via terminals or serial bus cascade controller only can work when drive in "Auto ON" mode	Staging/Destaging



## 1.6 Parameter Overview

Parameter Overview			
<b>0-** Operation / Display</b> <b>0-0* Basic Settings</b> <b>0-01 Language</b> *[0] English [1] Deutsch [2] Francais [3] Dansk [4] Espanol [5] Italiano [28] Portuguese [255] No Text <b>0-03 Regional Settings</b> *[0] International [1] US <b>0-04 Operating State at Power-up</b> *[0] Resume [1] Forced stop, ref=old <b>0-06 GridType</b> 0] 200-240 V/50 Hz/IT-grid [1] 200-240 V/50 Hz/Delta [2] 200-240 V/50 Hz [10] 380-440 V/50 Hz/IT-grid [11] 380-440 V/50 Hz/Delta [12] 380-440 V/50 Hz [20] 440-480 V/50 Hz/IT-grid [21] 440-480 V/50 Hz/Delta [22] 440-480 V/50 Hz [30] 525-600 V/50 Hz/IT-grid [31] 525-600 V/50 Hz/Delta [32] 525-600 V/50 Hz [100] 200-240 V/60 Hz/IT-grid [101] 200-240 V/60 Hz/Delta [102] 200-240 V/60 Hz [110] 380-440 V/60 Hz/IT-grid [111] 380-440 V/60 Hz/Delta [112] 380-440 V/60 Hz [120] 440-480 V/60 Hz/IT-grid [121] 440-480 V/60 Hz/Delta [122] 440-480 V/60 Hz [130] 525-600 V/60 Hz/IT-grid [131] 525-600 V/60 Hz/Delta [132] 525-600 V/60 Hz <b>0-07 Auto DC Braking IT</b> [0] Off *[1] On <b>0-1* Set-up Operations</b> <b>0-10 Active Set-up</b> *[1] Set-up 1 [2] Set-up 2 [9] Multi Set-up	<b>0-11 Programming Set-up</b> [1] Set-up 1 [2] Set-up 2 *[9] Active Set-up <b>0-12 Link Setups</b> [0] Not linked *[20] Linked <b>0-3* LCP Readout</b> <b>0-30 Custom Readout Unit</b> [0] None *[1] % [5] PPM [10] 1/Min [11] RPM [12] Pulse/s [20] l/s [21] l/min [22] l/h [23] m3/s [24] m3/min [25] m3/h [30] kg/s [31] kg/min [32] kg/h [33] t/min [34] t/h [40] m/s [41] m/min [45] m [60] Degree Celsius [70] mbar [71] bar [72] Pa [73] kPa [74] m Wg [80] kW [120] GPM [121] gal/s [122] gal/min [123] gal/h [124] CFM [127] ft3/h [140] ft/s [141] ft/min [160] Degree Fahr [170] psi [171] lb/in2 [172] in WG [173] ft WG [180] HP	<b>0-31 Custom Readout Min Value</b> 0.00 - 1,000,000.0, * 0.00 <b>0-32 Custom Readout Max Value</b> 0.00 - 1,000,000.0, * 100.00 <b>0-37 Display Text 1</b> <b>0-38 Display Text 2</b> <b>0-39 Display Text 3</b> <b>0-4* LCP Keypad</b> <b>0-40 [Hand on] Key on LCP</b> [0] Disabled *[1] Enabled <b>0-42 [Auto on] Key on LCP</b> [0] Disabled *[1] Enabled <b>0-44 [Off / Reset] Key on LCP</b> [0] Disable All *[1] Enable All [7] Enable Reset Only <b>0-5* Copy/Save</b> <b>0-50 LCP Copy</b> *[0] No copy [1] All to LCP [2] All from LCP [3] Size indep. from LCP <b>0-51 Set-up Copy</b> *[0] No copy [1] Copy from setup 1 [2] Copy from setup 2 [9] Copy from Factory setup <b>0-6* Password</b> <b>0-60 Main Menu Password</b> 0 - 999, * 0 <b>1-** Load and Motor</b> <b>1-0* General Settings</b> <b>1-00 Configuration Mode</b> *[0] Open loop [3] Closed loop <b>1-01 Motor Control Principle</b> [0] U/f *[1] VVC+ <b>1-03 Torque Characteristics</b> *[1] Variable torque [3] Auto Energy Optim. <b>1-06 Clockwise Direction</b> *[0] Normal [1] Inverse <b>1-20 Motor Power</b> [2] 0.12 kW - 0.16 Hp [3] 0.18 kW - 0.25 Hp [4] 0.25 kW - 0.33 Hp [5] 0.37 kW - 0.50 Hp	[6] 0.55 kW - 0.75 Hp [7] 0.75 kW - 1.00 Hp [8] 1.10 kW - 1.50 Hp [9] 1.50 kW - 2.00 Hp [10] 2.20 kW - 3.00 Hp [11] 3.00 kW - 4.00 Hp [12] 3.70 kW - 5.00 Hp [13] 4.00 kW - 5.40 Hp [14] 5.50 kW - 7.50 Hp [15] 7.50 kW - 10.0 Hp [16] 11.00 kW - 15.00 Hp [17] 15.00 kW - 20 Hp [18] 18.5 kW - 25 Hp [19] 22 kW - 30 Hp [20] 30 kW - 40 Hp [21] 37 kW-50 Hp [22] 45 kW-60 Hp [23] 55 kW-75 Hp [24] 75 kW-100 Hp [25] 90 kW-120 Hp [26] 110 kW-150 Hp <b>1-22 Motor Voltage</b> 50 - 1000 V <b>1-23 Motor Frequency</b> 20 - 400, *(50) Hz <b>1-24 Motor Current</b> 0.01 - (26.00), [A] <b>1-25 Motor Nominal Speed</b> 100 rpm - 6000 rpm, <b>1-29 Automatic Motor Adaption</b> 0 *[0] Off [1] Enable Complete [2] Enable Reduced <b>1-3* Adv. Motor Data I</b> <b>1-30 Stator Resistance (Rs)</b> 0.000 ohm - 99.990 ohm <b>1-33 Stator Leakage Reactance (X1)</b> 0.000 ohm - 999.900 ohm <b>1-35 Main Reactance (Xh)</b> 0.00 - 999.90 ohm <b>1-39 Motor Poles</b> 2 - 100, * 4 <b>1-4* Adv. Motor Data II</b> <b>1-42 Motor Cable Length</b> 0 - 150, * 50m <b>1-43 Motor Cable Length Feet</b> 0 - 431, * 144 <b>1-5* Load Indep. Setting</b>

Parameter Overview			
<p><b>1-50 Motor Magnetisation at Zero Speed</b> 0 - 300, * 100%</p> <p><b>1-52 Min Speed Normal Magnetising [Hz]</b> 0.0 - 10.0, * 0.0</p> <p><b>1-55 U/f Characteristic - U</b> 0 - 999 V, *0V</p> <p><b>1-56 U/f Characteristic - F</b> 0 - 400 Hz, *(0)</p> <p><b>1-6* Load Depend. Setting</b></p> <p><b>1-62 Slip Compensation</b> -400 - 399%, * 0%</p> <p><b>1-63 Slip Compensation Time Constant</b> 0.05 - 5.00 s, * 0.10</p> <p><b>1-64 Resonance Dampening</b> 0 - 500%, * 100</p> <p><b>1-65 Resonance Dampening Time Constant</b> 0.001 - 0.050 s, * 0.005</p> <p><b>1-7* Start Adjustments</b></p> <p><b>1-71 Start Delay</b> 0.0 - 10.0 s, * 0.0</p> <p><b>1-72 Start Function</b> [0] DC Hold/delay time *[2] Coast/delay time</p> <p><b>1-73 Flying Start</b> *[0] Disabled [1] Enabled</p> <p><b>1-8* Stop Adjustments</b></p> <p><b>1-80 Function at Stop</b> *[0] Coast [1] DC hold/MotorPreheat</p> <p><b>1-82 Min Speed for Function at Stop [Hz]</b> 0.0 - 20.0 Hz, * 0.0</p> <p><b>1-9* Motor Temperature</b></p> <p><b>1-90 Motor Thermal Protection</b> *[0] No protection [1] Thermistor warning [2] Thermistor trip [3] ETR warning 1 [4] ETR trip 1</p> <p><b>1-93 Thermistor Resource</b> *[0] None [1] Analog input 53 [6] Digital input 29</p> <p><b>2-** Brakes</b></p> <p><b>2-0* DC-Brake</b></p> <p><b>2-00 DC Hold/Motor Preheat Current</b> 0 - 160%, * 50</p> <p><b>2-01 DC Brake Current</b> 0 - 150%, * 50</p> <p><b>2-02 DC Braking Time</b> 0.0 - 60.0 s, * 10.0</p>	<p><b>2-04 DC Brake Cut In Speed</b> 0.0 - 400.0 Hz, * 0.0</p> <p><b>2-1* Brake Energy Funct.</b></p> <p><b>2-17 Over-voltage Control</b> [0] Disabled *[2] Enabled</p> <p><b>3-** Reference / Ramps</b></p> <p><b>3-0* Reference Limits</b></p> <p><b>3-02 Minimum Reference</b> (-4999.000) - 4999.000, * 0.000</p> <p><b>3-03 Maximum Reference</b> (-4999.000) - 4999.000, * 50.000</p> <p><b>3-1* References</b></p> <p><b>3-10 Preset Reference</b> -100.00 - 100.00 %, * 0.00</p> <p><b>3-11 Jog Speed [Hz]</b> 0.0 - 400.0 Hz, * 5.0</p> <p><b>3-14 Preset Relative Reference</b> -100.00 - 100.00, * 0.00</p> <p><b>3-15 Reference Resource 1</b> [0] No function *[1] Analog in 53 [2] Analog in 54 [11] Local bus reference</p> <p><b>3-16 Reference 2 Resource</b> [0] No function [1] Analog in 53 *[2] Analog in 54 [11] Local bus reference</p> <p><b>3-17 Reference 3 Resource</b> [0] No function [1] Analog in 53 [2] Analog in 54 *[11] Local bus reference</p> <p><b>3-4* Ramp 1</b></p> <p><b>3-41 Ramp 1 Ramp up Time</b> 0.05 - 3600.00 s, *Size related</p> <p><b>3-42 Ramp 1 Ramp Down Time</b> 0.05 - 3600.00 s, *Size related</p> <p><b>3-5* Ramp 2</b></p> <p><b>3-51 Ramp 2 Ramp up Time</b> 0.05 - 3600.00 s, *Size related</p> <p><b>3-52 Ramp 2 Ramp down Time</b> 0.05 - 3600.00 s, *Size related</p> <p><b>3-8* Other Ramps</b></p> <p><b>3-80 Jog Ramp Time</b> 0.05 - 3600.00 s, *Size related</p> <p><b>3-81 Quick Stop Ramp Time</b> 0.05 - 3600.00 s, *Size related</p> <p><b>4-** Limits / Warnings</b></p> <p><b>4-1* Motor Limits</b></p> <p><b>4-10 Motor Speed Direction</b> [0] Clockwise *[2] Both directions</p> <p><b>4-12 Motor Speed Low Limit [Hz]</b> 0.0 - 400 Hz, * 0.0 Hz</p>	<p><b>4-14 Motor Speed High Limit [Hz]</b> 0.1 - 400 Hz, * 65.0 Hz</p> <p><b>4-18 Current Limit</b> 0 - 300%, * 110</p> <p><b>4-19 Max Output Frequency</b> 0.0 - 400.0 Hz, * 65.0</p> <p><b>4-4* Adj. Warnings 2</b> 4-40 Warning Freq. Low 0.0-400.0 Hz, *400.0 4-41 Warning Freq. High 0.0-400.0 Hz, *400.0</p> <p><b>4-5* Adj. Warnings</b></p> <p><b>4-50 Warning Current Low</b> 0.00 - 194.00 A, * 0.00</p> <p><b>4-51 Warning Current High</b> 0.00 - 194.00 A, * 194.00</p> <p><b>4-54 Warning Reference Low</b> -4999.000 - 4999.000, *-4999.000</p> <p><b>4-55 Warning Reference High</b> -4999.000 - 4999.000, *4999.000</p> <p><b>4-56 Warning Feedback Low</b> -4999.000 - 4999.000, *-4999.000</p> <p><b>4-57 Warning Feedback High</b> -4999.000 - 4999.000, *4999.000</p> <p><b>4-58 Missing Motor Phase Function</b> [0] Off *[1] On</p> <p><b>4-6* Speed Bypass</b></p> <p><b>4-61 Bypass Speed From [Hz]</b> 0.0 - 400.0, * 0.0</p> <p><b>4-63 Bypass Speed To [Hz]</b> 0.0 - 400.0, * 0.0</p> <p><b>4-64 Semi-Auto Bypass Set-up</b> *[0] Off [1] Enable</p> <p><b>5-** Digital In/Out</b></p> <p><b>5-0* Digital I/O mode</b></p> <p><b>5-00 Digital Input Mode</b> *[0] PNP [1] NPN</p> <p><b>5-03 Digital Input 29 Mode</b> *[0] PNP [1] NPN</p> <p><b>5-1* Digital Inputs</b></p> <p><b>5-10 Terminal 18 Digital Input</b> [0] No operation [1] Reset [2] Coast inverse [3] Coast and reset inverse [4] Quick stop inverse [5] DC-brake inverse [6] Stop inverse [7] External Interlock *[8] Start</p>	<p>[9] Latched start</p> <p>[10] Reversing</p> <p>[11] Start reversing</p> <p>[14] Jog</p> <p>[16] Preset ref bit 0</p> <p>[17] Preset ref bit 1</p> <p>[18] Preset ref bit 2</p> <p>[19] Freeze reference</p> <p>[20] Freeze output</p> <p>[21] Speed up</p> <p>[22] Speed down</p> <p>[23] Set-up select bit 0</p> <p>[34] Ramp bit 0</p> <p>[37] Fire mode</p> <p>[52] Run permissive</p> <p>[53] Hand Start</p> <p>[54] Auto start</p> <p>[60] Counter A (up)</p> <p>[61] Counter A (down)</p> <p>[62] Reset Counter A</p> <p>[63] Counter B (up)</p> <p>[64] Counter B (down)</p> <p>[65] Reset Counter B</p> <p>[120] Lead Pump Start</p> <p>[121] Lead Pump Alternation</p> <p>[130] Pump 1 Interlock</p> <p>[131] Pump 2 Interlock</p> <p>[132] Pump 3 Interlock</p> <p>[133] Pump 4 Interlock</p> <p>[134] Pump 5 Interlock</p> <p><b>5-11 Terminal 19 Digital Input</b> See par. 5-10, *[0] No operation</p> <p><b>5-12 Terminal 27 Digital Input</b> See par. 5-10, *[2] Coast inverse</p> <p><b>5-13 Terminal 29 Digital Input</b> See par. 5-10, *[14 Jog]</p> <p><b>5-3* Digital Outputs</b></p> <p><b>5-34 On Delay, Digital Output</b> 0.00 - 600.00 s, *0.01 s</p> <p><b>5-35 Off Delay, Digital Output</b> 0.00 - 600.00 s, *0.01 s</p> <p><b>5-4* Relays</b></p> <p><b>5-40 Function Relay</b> *[0] No operation [1] Control ready [2] Drive ready [3] Drive ready/remote control [4] Enable / no warning [5] VLT running [6] Running / no warning [7] Run in range/no warning [8] Run on ref/no warning [9] Alarm [10] Alarm or warning [12] Out of current range [13] Below current, low</p>

Parameter Overview			
[14] Above current, high	0 - 0xFFFFFFFF, * 0	<b>6-7* Analog Output 45</b>	[167] Start command activ
[16] Below frequency, low	<b>6-** Analog In/Out</b>	<b>6-70 Terminal 45 Mode</b>	[168] Drive in hand mode
[17] Above frequency, high	<b>6-0* Analog I/O Mode</b>	*[0] 0-20 mA	[169] Drive in auto mode
[19] Below feedback, low	<b>6-00 Live Zero Timeout Time</b>	[1] 4-20 mA	[193] Sleep Mode
[20] Above feedback, high	1 - 99s, * 10	[2] Digital Output	[194] Broken Belt Function
[21] Thermal warning	<b>6-01 Live Zero Timeout Function</b>	<b>6-71 Terminal 45 Analog Output</b>	[196] Fire Mode
[22] Ready, no thermal warning	*[0] Off	*[0] No operation	[198] Bypass Mode
[23] Remote, ready, no thermal warning	[1] Freeze output	[100] Output frequency	[200] Full capacity
[24] Ready, Voltage OK	[2] Stop	[101] Reference	[201] Pump 1 running
[25] Reverse	[3] Jogging	[102] Feedback	[202] Pump 2 running
[26] Bus OK	[4] Max. speed	[103] Motor current	[203] Pump 3 running
[35] External Interlock	[5] Stop and trip	[106] Power	[204] Pump 4 running
[36] Control word bit 11	<b>6-1* Analog Input 53</b>	[139] Bus Control	[205] Pump 5 running
[37] Control word bit 12	<b>6-10 Terminal 53 Low Voltage</b>	<b>6-72 Terminal 45 Digital Output</b>	[211] Cascade Pump 1
[45] Bus Control	0.00 - 10.00 V, * 0.07	*[0] No operation	[212] Cascade Pump 2
[60] Comparator 0	<b>6-11 Terminal 53 High Voltage</b>	[1] Control ready	[213] Cascade Pump 3
[61] Comparator 1	0.00 - 10.00 V, * 10.00	[2] Drive ready	[214] Cascade Pump 4
[62] Comparator 2	<b>6-12 Terminal 53 Low Current</b>	[3] Drive ready/remote control	[215] Cascade Pump 5
[63] Comparator 3	0.00 - 20.00, * 4.00 mA	[4] Standby / no warning	<b>6-73 Terminal 45 Output Min Scale</b>
[64] Comparator 4	<b>6-13 Terminal 53 High Current</b>	[5] Drive running	0.00 - 200.00%, * 0.00
[65] Comparator 5	0.00 - 20.00, * 20.00 mA	[6] Running / no warning	<b>6-74 Terminal 45 Output Max Scale</b>
[70] Logic rule 0	<b>6-14 Terminal 53 Low Ref./Feedb. Value</b>	[7] Run in range/no warning	0.00 - 200.00%, * 100.00
[71] Logic rule 1	-4999.000 - 4999.000, * 0.000	[8] Run on ref/no warning	<b>6-76 Terminal 45 Output Bus Control</b>
[72] Logic rule 2	<b>6-15 Terminal 53 High Ref./Feedb. Value</b>	[9] Alarm	0.00 - 100.00%, * 0.00
[73] Logic rule 3	-4999.000 - 4999.000, * 50.000	[10] Alarm or warning	<b>6-9* Analog Output 42</b>
[74] Logic rule 4	<b>6-16 Terminal 53 Filter Time Constant</b>	[12] Out of current range	<b>6-90 Terminal 42 Mode</b>
[75] Logic rule 5	0.01 - 10.00 s, * 0.01	[13] Below current, low	*[0] 0-20 mA
[80] SL digital output A	<b>6-19 Terminal 53 mode</b>	[14] Above current, high	[1] 4-20 mA
[81] SL digital output B	[0] Current mode	[21] Thermal warning	[2] Digital Output
[82] SL digital output C	*[1] Voltage mode	[22] Ready, no thermal warning	<b>6-91 Terminal 42 Analog Output</b>
[83] SL digital output D	<b>6-2* Analog Input 54</b>	[23] Remote, ready, no thermal warning	*[0] No operation
[160] No alarm	<b>6-20 Terminal 54 Low Voltage</b>	[24] Ready, Voltage OK	[100] Output frequency
[161] Running reverse	0.00 - 10.00V, * 0.07	[25] Reverse	[101] Reference
[165] Local ref. active	<b>6-21 Terminal 54 High Voltage</b>	[26] Bus OK	[102] Feedback
[166] Remote ref. active	0.00 - 10.00V, * 10.00	[35] External Interlock	[103] Motor current
[167] Start command activ	<b>6-22 Terminal 54 Low Current</b>	[45] Bus Control	[105] TorquereltoRated
[168] Drive in hand mode	0.00 - 20.00, * 4.00mA	[60] Comparator 0	[106] Power
[169] Drive in auto mode	<b>6-23 Terminal 54 High Current</b>	[61] Comparator 1	[139] Bus Control
[193] Sleep Mode	0.00 - 20.00, * 20.00mA	[62] Comparator 2	<b>6-92 Terminal 42 Digital Output</b>
[194] Broken Belt Function	<b>6-24 Terminal 54 Low Ref./Feedb. Value</b>	[63] Comparator 3	*[0] No operation
[196] Fire Mode	-4999.000 - 4999.000, * 0.000	[64] Comparator 4	[1] Control ready
[198] Drive Bypass	<b>6-25 Terminal 54 High Ref./Feedb. Value</b>	[65] Comparator 5	[2] Drive ready
[211] Cascade Pump 1	-4999.000 - 4999.000, * 50.000	[70] Logic rule 0	[3] Drive ready/remote control
[212] Cascade Pump 2	<b>6-26 Terminal 54 Filter Time Constant</b>	[71] Logic rule 1	[4] Enable / no warning
[213] Cascade Pump 3	0.01 - 10.00, * 0.01	[72] Logic rule 2	[5] Drive running
[214] Cascade Pump 4	<b>6-29 Terminal 54 mode [0]</b>	[73] Logic rule 3	[6] Running / no warning
[215] Cascade Pump 55-41 On Delay, Relay	<b>6-29 Terminal 54 mode [0]</b>	[74] Logic rule 4	[7] Run in range/no warning
0.00 - 600.00 s, *0.01 s	<b>Current mode</b>	[75] Logic rule 5	[8] Run on ref/no warning
<b>5-42 Off Delay, Relay</b>	[0] Current mode	[80] SL digital output A	[9] Alarm
0.00 - 600.00 s, *0.01 s	*[1] Voltage mode	[81] SL digital output B	[10] Alarm or warning
<b>5-5* Pulse Input</b>		[82] SL digital output C	[12] Out of current range
<b>5-9* Bus Controlled</b>		[83] SL digital output D	[13] Below current, low
<b>5-90 Digital and Relay Bus Control</b>		[160] No alarm	[14] Above current, high
		[161] Running reverse	[21] Thermal warning
		[165] Local ref. active	
		[166] Remote ref. active	

Parameter Overview			
[22] Ready, no thermal warning	*[0] Digital and ctrl.word	[1] Bus	<b>8-9* Bus Feedback</b>
[23] Remote, ready, no thermal warning	[1] Digital only	[2] Logic AND	<b>8-94 Bus feedback 1</b>
[24] Ready, Voltage OK	[2] Controlword only	*[3] Logic OR	-32768 - 32767, * 0
[25] Reverse	<b>8-02 Control Source</b>	<b>8-52 DC Brake Select</b>	<b>13-** Smart Logic</b>
[26] Bus OK	[0] None	[0] Digital input	<b>13-0* SLC Settings</b>
[35] External Interlock	*[1] FC Port	[1] Bus	<b>13-00 SL Controller Mode</b>
[45] Bus Control	<b>8-03 Control Timeout Time</b>	[2] Logic AND	*[0] Off
[60] Comparator 0	0.1 - 6500.0s, * 1.0	*[3] Logic OR	[1] On
[61] Comparator 1	<b>8-04 Control Timeout Function</b>	<b>8-53 Start Select</b>	<b>13-01 Start Event</b>
[62] Comparator 2	*[0] Off	[0] Digital input	[0] False
[63] Comparator 3	[1] Freeze output	[1] Bus	[1] True
[64] Comparator 4	[2] Stop	[2] Logic AND	[2] Running
[65] Comparator 5	[3] Jogging	*[3] Logic OR	[3] In range
[70] Logic rule 0	[4] Max. speed	<b>8-54 Reversing Select</b>	[4] On reference
[71] Logic rule 1	[5] Stop and trip	[0] Digital input	[7] Out of current range
[72] Logic rule 2	[20] N2 Override Release	[1] Bus	[8] Below I <sub>low</sub>
[73] Logic rule 3	<b>8-06 Reset Control Word Timeout</b>	[2] Logic AND	[9] Above I <sub>high</sub>
[74] Logic rule 4	*[0] No function	*[3] Logic OR	[16] Thermal warning
[75] Logic rule 5	[1] Do reset	<b>8-55 Set-up Select</b>	[17] Mains out of range
[80] SL digital output A	<b>8-3* FC Port Settings</b>	[0] Digital input	[18] Reversing
[81] SL digital output B	<b>8-30 Protocol</b>	[1] Bus	[19] Warning
[82] SL digital output C	*[0] FC	[2] Logic AND	[20] Alarm (trip)
[83] SL digital output D	[2] Modbus RTU	*[3] Logic OR	[21] Alarm (trip lock)
[160] No alarm	[3] Metasys N2	<b>8-56 Preset Reference Select</b>	[22] Comparator 0
[161] Running reverse	[4] FLN	[0] Digital input	[23] Comparator 1
[165] Local ref. active	[5] BACNet	[1] Bus	[24] Comparator 2
[166] Remote ref. active	<b>8-31 Address</b>	[2] Logic AND	[25] Comparator 3
[167] Start command activ	1 - 247 , * 1	*[3] Logic OR	[26] Logic rule 0
[168] Drive in hand mode	<b>8-32 FC Port Baud Rate</b>	<b>8-7* Bacnet</b>	[27] Logic rule 1
[169] Drive in auto mode	[0] 2400 Baud	<b>8-70 BACnet Device Instance</b>	[28] Logic rule 2
[193] Sleep Mode	[1] 4800 Baud	0 - 0x400000UL	[29] Logic rule 3
[194] Broken Belt Function	*[2] 9600 Baud	* 1	[33] Digital input 18
[196] Fire Mode	[3] 19200 Baud	<b>8-72 MS/TP Maxmaster</b>	[34] Digital input 19
[198] Drive Bypass	[4] 38400 Baud	0 - 127, * 127	[35] Digital input 27
[200] Full capacity	[5] 57600 Baud	<b>8-73 MS/TP Max Info Frames</b>	[36] Digital input 29
[201] Pump 1 running	[6] 76800 Baud	1 - 65534, * 1	*[39] Start command
[202] Pump 2 running	[7] 115200 Baud	<b>8-74 "I am" Service</b>	[40] Drive stopped
[203] Pump 3 running	<b>8-33 FC Port Parity</b>	*[0] Send at power-up	[41] Reset trip
[204] Pump 4 running	*[0] Even Parity, 1 Stop Bit	[1] Continuously	[42] Auto reset trip
[205] Pump 5 running	[1] Odd Parity, 1 Stop Bit	<b>8-75 Intialisation Password</b>	[43] Key Ok
[211] Cascade Pump 1	[2] No Parity, 1 Stop Bit	<b>8-8* FC Port Diagnostics</b>	[44] Key Reset
[212] Cascade Pump 2	[3] No Parity, 2 Stop Bits	<b>8-80 Bus Message Count</b>	[47] Key Up
[213] Cascade Pump 3	<b>8-35 Minimum Response Delay</b>	0 - 65536, * 0	[48] Key Down
[214] Cascade Pump 4	0.001 - 0.500s, * 0.010	<b>8-81 Bus Error Count</b>	[50] Comparator 4
[215] Cascade Pump 5	<b>8-36 Max Response Delay</b>	0 - 65536, * 0	[51] Comparator 5
<b>6-93 Terminal 42 Output Min Scale</b>	0.100 - 10.000s, *5.000	<b>8-82 Slave Message Rcvd</b>	[60] Logic rule 4
0.00 - 200.00%, * 0.00	<b>8-37 Max Inter-char delay</b>	0 - 65536, * 0	[83] Broken belt
<b>6-94 Terminal 42 Output Max Scale</b>	0.025 - 0.025s, * 0.025	<b>8-83 Slave Error Count</b>	<b>13-02 Stop Event</b>
0.00 - 200.00%, * 100.00	<b>8-5* Digital/Bus</b>	0 - 65536, * 0	See par. 13-02, *[40] Drive stopped
<b>6-96 Terminal 42 Output Bus Control</b>	<b>8-50 Coasting Select</b>	<b>8-84 Slave Message Sent</b>	<b>13-03 Reset SLC</b>
0.00 - 100.00%, * 0.00	[0] Digital input	0 - 65536, * 0	*[0] Do not reset
<b>8-** Comm. and Options</b>	[1] Bus	<b>8-85 Slave Timeout Errors</b>	[1] Reset SLC
<b>8-0* Comm. General Settings</b>	[2] Logic AND	0 - 65536, * 0	<b>13-1* Comparators</b>
<b>8-01 Control Site</b>	*[3] Logic OR	<b>8-88 Reset FC port Diagnostics</b>	<b>13-10 Comparator Operand</b>
	<b>8-51 Quick Stop Select</b>	*[0] Do not reset	*[0] Disabled
	[0] Digital input	[1] Reset counter	[1] Reference

Parameter Overview			
[2] Feedback	[19] Select ramp 2	[1] Automatic reset x 1	<b>15-00 Operating Hours</b>
[3] Motor speed	[22] Run	[2] Automatic reset x 2	0 - 2147483647, * 0
[4] Motor current	[23] Run reverse	[3] Automatic reset x 3	<b>15-01 Running Hours</b>
[6] Motor power	[24] Stop	[4] Automatic reset x 4	0 - 2147483647, * 0
[7] Motor voltage	[25] Qstop	[5] Automatic reset x 5	<b>15-02 kWh Counter</b>
[8] DC-link voltage	[26] DC Brake	[6] Automatic reset x 6	0 - 65535, * 0
[12] Analog in 53	[27] Coast	[7] Automatic reset x 7	<b>15-03 Power Up's</b>
[13] Analog in 54	[28] Freeze output	[8] Automatic reset x 8	0 - 2147483647, * 0
[20] Alarm number	[29] Start timer 0	[9] Automatic reset x 9	<b>15-04 Over Temp's</b>
[30] Counter A	[30] Start timer 1	[10] Automatic reset x 10	0 - 65535, * 0
[31] Counter B	[31] Start timer 2	[11] Automatic reset x 15	<b>15-05 Over Volt's</b>
<b>13-11 Comparator Operator</b>	[32] Set digital out A low	[12] Automatic reset x 20	0 - 65535, * 0
[0] Less Than	[33] Set digital out B low	[13] Infinite auto reset	<b>15-06 Reset kWh Counter</b>
*[1] Approx. Equal	[34] Set digital out C low	<b>14-21 Automatic Restart Time</b>	*[0] Do not reset
[2] GreaterThan	[35] Set digital out D low	0 - 600s, * 10	[1] Reset counter
<b>13-12 Comparator Value</b>	[38] Set digital out A high	<b>14-22 Operation Mode</b>	<b>15-07 Reset Running Hours Counter</b>
-9999.0 - 9999.0, * 0.0	[39] Set digital out B high	*[0] Normal operation	*[0] Do not reset
<b>13-2* Timers</b>	[40] Set digital out C high	[2] Initialisation	[1] Reset counter
<b>13-20 SL Controller Timer</b>	[41] Set digital out D high	<b>14-27 Action At Inverter Fault</b>	<b>15-3* Fault Log</b>
0.00 - 3600.00, * 0.00	[60] Reset Counter A	[0] Off	<b>15-30 Fault Log:</b>
<b>13-4* Logic Rules</b>	[61] Reset Counter B	*[1] On	Error Code 0 - 255, * 0
<b>13-40 Logic Rule Boolean 1</b>	[70] Start timer 3	<b>14-28 Production Settings</b>	<b>15-4* Drive Identification</b>
See par. 13-01, *[0] False	[71] Start timer 4	*[0] No action	<b>15-40 FC Type</b>
<b>13-41 Logic Rule Operator 1</b>	[72] Start timer 5	[1] Service reset	<b>15-41 Power Section</b>
*[0] Disabled	[73] Start timer 6	[3] Software Reset	<b>15-42 Voltage</b>
[1] AND	[74] Start timer 7	<b>14-29 Service Code</b>	<b>15-43 Software Version</b>
[2] OR	[100] Reset Alarm	0 - 0x7FFFFFFF, * 0	<b>15-44 OrderedTypeCode</b>
[3] AND NOT	<b>14-** Special Functions</b>	<b>14-3* Current Limit Ctrl.</b>	<b>15-46 Frequency Converter</b>
[4] OR NOT	<b>14-0* Inverter Switching</b>	<b>14-4* Energy Optimising</b>	Ordering No
[5] NOT AND	<b>14-01 Switching Frequency</b>	<b>14-40 VT Level</b>	<b>15-47 Power Card Ordering No</b>
[6] NOT OR	[0] Ran3	40 - 90%, * 90%	<b>15-48 LCP Id No</b>
[7] NOT AND NOT	[1] Ran5	<b>14-41 AEO Minimum Magnetisation</b>	<b>15-49 Software ID Control Card</b>
[8] NOT OR NOT	[2] 2.0 kHz	40 - 75%, * 66	<b>15-50 Software ID Power Card</b>
<b>13-42 Logic Rule Boolean 2</b>	[3] 3.0 kHz	<b>14-5* Environment</b>	<b>15-51 Frequency Converter Serial</b>
See par. 13-01, *[0] False	[4] 4.0 kHz	<b>14-50 RFI Filter</b>	<b>Number</b>
<b>13-43 Logic Rule Operator 2</b>	[5] 5.0 kHz	[0] Off	<b>15-53 Power Card Serial Number</b>
See par. 13-41, *[0] Disabled	[6] 6.0 kHz	*[1] On	<b>16-** Data Readouts</b>
<b>13-44 Logic Rule Boolean 3</b>	[7] 8.0 kHz	<b>14-51 DC-link Voltage Compensation</b>	<b>16-0* General Status</b>
See par. 13-01, *[0] False	[8] 10.0 kHz	[0] Off	<b>16-00 Control Word</b>
<b>13-5* States</b>	[9] 12.0kHz	*[1] On	0 - 65535, * 0
<b>13-51 SL Controller Event</b>	[10] 16.0kHz	<b>14-52 Fan Control</b>	<b>16-01 Reference [Unit]</b>
See par. 13-01, *[0] False	<b>14-03 Overmodulation</b>	*[0] Auto	-4999.000 - 4999.000, * 0.000
<b>13-52 SL Controller Action</b>	[0] Off	[4] Auto Low temp env	<b>16-02 Reference</b>
*[0] Disabled	*[1] On	<b>14-53 Fan Monitor</b>	% -200.0 - 200.0, * 0.0
[1] No action	<b>14-08 Damping Gain Factor</b>	[0] Disabled	<b>16-03 Status Word</b>
[2] Select set-up 1	0 - 100-%, * 96	*[1] Warning	0 - 65535, * 0
[3] Select set-up 2	<b>14-1* Mains on/off</b>	[2] Trip	<b>16-05 Main Actual Value [%]</b>
[10] Select preset ref 0	<b>14-12 Function at Mains</b>	*[1] Warning	-200.00 - 200.00, * 0.00
[11] Select preset ref 1	<b>Imbalance</b>	[2] Trip	<b>16-09 Custom Readout</b>
[12] Select preset ref 2	*[0] Trip	<b>14-55 Output Filter</b>	0.00 - 9999.00, * 0.00
[13] Select preset ref 3	[1] Warning	*[0] No Filter	<b>16-1* Motor Status</b>
[14] Select preset ref 4	[2] Disabled	[1] Sine-Wave Filter	<b>16-10 Power [kW]</b>
[15] Select preset ref 5	[3] Derate	[3] Sine-Wave Filter with Feedback	0.000-4.294, 967.500, *0.000
[16] Select preset ref 6	<b>14-2* Reset Functions</b>	<b>14-63 Min Switch Frequency</b>	<b>16-11 Power [hp]</b>
[17] Select preset ref 7	<b>14-20 Reset Mode</b>	1 - 16kHz, * 1	0.000 - 2.294, 967.500 *0.000
[18] Select ramp 1	*[0] Manual reset	<b>15-** Drive Information</b>	<b>16-3* Drive Status</b>
		<b>15-0* Operating Data</b>	

Parameter Overview			
<b>16-30 DC Link Voltage</b> 0 - 65535, * 0 <b>16-34 Heatsink Temp.</b> 0 - 255, * 0 <b>16-35 Inverter Thermal</b> 0 - 255%, * 0 <b>16-36 Inv. Nom. Current</b> 0.00 - 655.35, * 0.00 <b>16-37 Inv. Max. Current</b> 0.00 - 655.35 <b>16-38 SL Controller State</b> 0 - 255, * 0 <b>16-5* Ref. and Feedb.</b> <b>16-50 External Reference</b> -200.0 - 200.0%, * 0.0 <b>16-52 Feedback</b> -4999.000 - 4999.000, * 0.000 <b>16-6* Inputs and Outputs</b> <b>16-60 Digital input</b> 0 - 65535, * 0 <b>16-61 Terminal 53 Setting</b> *[0] Current mode [1] Voltage mode <b>16-62 Analog Input 53</b> 0.00 - 10.00, * 1.00 <b>16-63 Terminal 54 Setting</b> *[0] Current mode [1] Voltage mode <b>16-64 Analog Input 54</b> 0.00 - 20.00, * 1.00 <b>16-65 Analog Output 42 [mA]</b> 0.00 - 20.00, * 0.00 <b>16-61 Digital Output</b>	<b>16-72 Counter A</b> -32768 - 32767, * 0 <b>16-73 Counter B</b> -32768 - 32767, * 0 <b>16-79 Analog output 45</b> 20 - 20mA, * 0 <b>16-8* Fieldbus / FC Port</b> <b>16-86 FC Port REF 1</b> -32768 - 32767, * 0 <b>16-9* Diagnosis Readouts</b> <b>16-90 Alarm Word</b> 0 - 0xFFFFFFFFFUL, * 0 <b>16-91 Alarm Word 2</b> 0 - 0xFFFFFFFFFUL, * 0 <b>16-92 Warning Word</b> 0 - 0x7FFFFFFFUL, * 0 <b>16-93 Warning Word 2</b> 0 - 0x7FFFFFFFUL, * 0 <b>16-94 Ext. Status Word</b> 0 - 0x7FFFFFFFUL, * 0 <b>16-95 Ext. Status Word 2</b> 0 - 0x7FFFFFFFUL, * 0 <b>18-**Extended Motor Data</b> <b>18-1* Firemode Log</b> <b>18-10 Firemode log: Event</b> 0-255, *0 <b>20-** FC Closed Loop</b> <b>20-0* Feedback</b> <b>20-00 Feedback 1 Source</b> *[0] No function [1] Analog in 53 [2] Analog in 54 [100] Bus Feedback 1	<b>20-01 Feedback 1 Conversion</b> *[0] Linear [1] Square root <b>20-8* PI Basic Setting</b> <b>20-81 Process PI Normal/ Inverse Control</b> *[0] Normal [1] Inverse <b>20-83 Process PI Start Speed[Hz]</b> 0.0 - 200.0, * 0.0 <b>20-84 On Reference Bandwidth</b> 0 - 200%, * 5 <b>20-9* PI Controller</b> <b>20-91 PI Anti Windup</b> [0] Off *[1] On <b>20-93 PI Proportional Gain</b> 0.00 - 10.00, * 0.01 <b>20-94 PI Integral Time</b> 0.10 - 9999.00s, * 9999.00 <b>20-97 Process PI Feed Forward Factor</b> 0 - 400%, * 0 <b>22-** Appl. functions</b> <b>22-4* Sleep mode</b> <b>22-40 Minimum Run Time</b> 0 - 600 s, * 10 <b>22-41 Minimum Sleep Time</b> 0 - 600 s, * 10 <b>22-43 Wake-Up Speed [Hz]</b> 0.0 - 400.0, * 100.0 <b>22-44 Wake-Up Ref./FB difference</b> 0 - 100%, * 10	<b>22-45 Setpoint Boost</b> -100 - 100%, * 0 <b>22-46 Maximum Boost Time</b> 0 - 600 s, * 60 <b>22-47 Sleep Speed [Hz]</b> 0.0 - 400.0, * 0.0 <b>22-6* Broken Belt Detection</b> <b>22-60 Broken Belt Detection</b> *[0] Off [1] Warning [2] Trip <b>22-61 Broken Belt Torque</b> 5 - 100%, * 10 <b>22-62 Broken Belt Delay</b> 0 - 600 s, * 10 <b>24-** Appl. functions 2</b> <b>24-0* Fire mode</b> <b>24-00 Fire Mode Function</b> *[0] Disabled [1] Enabled Run Forward [2] Enabled Run Reverse [3] Enable-Coast [4] Enabled - Run Fwd/Rev <b>24-05 Fire Mode Preset Reference</b> -100 - 100%, * 0 <b>24-09 Fire Mode Alarm Handling</b> *[1] Trip, Critical Alarms [2] Trip, All Alarms/Test <b>24-1* Drive Bypass</b> <b>24-10 Drive Bypass Function</b> *[0] Disabled [2] Enabled (Fire Mode only) <b>24-11 Bypass Delay Timer</b> 0 - 600 s, * 0

### 1.7 Warnings and Alarms

Fault number	Alarm/Warning Bit Number	Fault text	Warning	Alarm	Trip locked	Cause of problem
2	16	Live zero error	X	X		Signal on terminal 53 or 54 is less than 50% of value set in 6-10 Terminal 53 Low Voltage, 6-12 Terminal 53 Low Current, 6-20 Terminal 54 Low Voltage or 6-22 Terminal 54 Low Current. See also parameter group 6-0*
4	14	Mains ph. loss	X	X	X	Missing phase on supply side or too high voltage imbalance. Check supply voltage. See 14-12 Function at Mains Imbalance
7	11	DC over volt	X	X		Intermediate circuit voltage exceeds limit.
8	10	DC under volt	X	X		Intermediate circuit voltage drops below "voltage warning low" limit.
9	9	Inverter overload	X	X		More than 100% load for too long.
10	8	Motor ETR over	X	X		Motor is too hot due to more than 100% load for too long. See 1-90 Motor Thermal Protection

Fault number	Alarm/Warning Bit Number	Fault text	Warning	Alarm	Trip locked	Cause of problem
11	7	Motor th over	X	X		Thermistor or thermistor connection is disconnected. See <i>1-90 Motor Thermal Protection</i>
13	5	Over Current	X	X	X	Inverter peak current limit is exceeded.
14	2	Earth Fault		X	X	Discharge from output phases to ground.
16	12	Short Circuit		X	X	Short-circuit in motor or on motor terminals.
17	4	Ctrl.word TO	X	X		No communication to frequency converter. See parameter group 8-0*
24	50	Fan Fault	X	X		The fan is not working (Only on 400 V 30-90 kW units).
30	19	U phase loss		X	X	Motor phase U is missing. Check the phase. See <i>4-58 Missing Motor Phase Function</i> .
31	20	V phase loss		X	X	Motor phase V is missing. Check the phase. See <i>4-58 Missing Motor Phase Function</i> .
32	21	W phase loss		X	X	Motor phase W is missing. Check the phase. See <i>4-58 Missing Motor Phase Function</i> .
38	17	Internal fault		X	X	Contact your local Danfoss supplier.
40	10	Overload on Terminal 27, Digital Output	X			Overload on Terminal 27, Digital Output
41	11	Overload on Terminal 29, Digital Output	X			Overload on Terminal 29, Digital Output
44	28	Earth Fault		X	X	Discharge from output phases to ground.
47	23	Control Voltage Fault	X	X	X	24 V DC may be overloaded.
48	25	VDD1 Supply Low		X	X	Control voltage low. Please contact your local Danfoss supplier
50		AMA Calibration failed		X		Contact your local Danfoss supplier.
51	15	AMA Unom,Inom		X		The setting of motor voltage, motor current and motor power is presumably wrong. Check the settings.
52		AMA low Inom		X		The motor current is too low. Check the settings.
53		AMA big motor		X		The motor is too big for the AMA to be carried out
54		AMA small mot		X		The motor is too small for the AMA to be carried out
55		AMA par. range		X		The parameter values found from the motor are outside acceptable range
56		AMA user interrupt		X		The AMA has been interrupted by the user
57		AMA timeout		X		Try to start the AMA again a number of times, until the AMA is carried out. Please note that repeated runs may heat the motor to a level where the resistance $R_s$ and $R_r$ are increased. In most cases, however, this is not critical
58		AMA internal	X	X		Contact your local Danfoss supplier.
59	25	Current limit	X			The current is higher than the value in <i>4-18 Current Limit</i>
60	44	External Interlock		X		External interlock has been activated. To resume normal operation, apply 24 V DC to the terminal programmed for external interlock and reset the frequency converter (via serial communication, digital I/O, or by pressing reset button on keypad).



Fault number	Alarm/Warning Bit Number	Fault text	Warning	Alarm	Trip locked	Cause of problem
66	26	Heat sink Temperature Low	X			This warning is based on the temperature sensor in the IGBT module (Only on 400 V 30-90 kW units).
69	1	Pwr. Card Temp	X	X	X	The temperature sensor on the power card is either too hot or too cold.
79		Illegal power section configuration	X	X		Internal fault. Contact your local Danfoss supplier.
80	29	Drive initialised		X		All parameter settings are initialized to default settings.
87	47	Auto DC Braking	X			The drive is auto DC braking
95	40	Broken Belt	X	X		Torque is below the torque level set for no load, indicating a broken belt. See parameter group 22-6*.
200		Fire Mode	X			Fire mode has been activated
202		Fire Mode Limits Exceeded	X			Fire Mode has suppressed one or more warranty voiding alarms
250		New sparepart		X	X	The power or switch mode power supply has been exchanged. (Only on 400 V 30-90 kW units). Contact your local Danfoss supplier
251		New Typecode		X	X	The frequency converter has a new type code (Only on 400 V 30-90 kW units). Contact your local Danfoss supplier.

1

1.8.1 Mains Supply 3x380-480 V AC

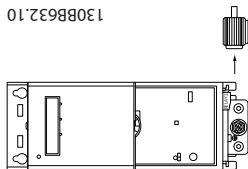
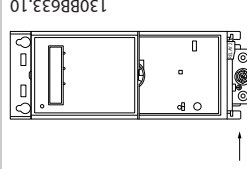
Frequency converter		PK37	PK75	P1K5	P2K2	P3K0	P4K0	P5K5	P7K5	P11K	P15K	P18K	P22K	P30K	P37K	P45K	P55K	P75K	P90K
Typical shaft output [kW]		0.37	0.75	1.5	2.2	3.0	4.0	5.5	7.5	11.0	15.0	18.5	22.0	30.0	37.0	45.0	55.0	75.0	90.0
Typical shaft output [hp]		0.5	1.0	2.0	3.0	4.0	5.0	7.5	10.0	15.0	20.0	25.0	30.0	40.0	50.0	60.0	70.0	100.0	125.0
IP20 frame		H1	H1	H1	H2	H2	H2	H3	H3	H4	H4	H5	H5	H6	H6	H6	H7	H7	H8
Max. cable size in terminals (mains, motor) [mm <sup>2</sup> /AWG]		4/10	4/10	4/10	4/10	4/10	4/10	4/10	4/10	16/6	16/6	16/6	16/6	35/2	35/2	35/2	50/1	95/0	120/25 0MCM
<b>Output current</b>																			
40°C ambient temperature																			
	Continuous (3x380-440 V) [A]	1.2	2.2	3.7	5.3	7.2	9.0	12.0	15.5	23.0	31.0	37.0	42.5	61.0	73.0	90.0	106.0	147.0	177.0
	Intermittent (3x380-440 V) [A]	1.3	2.4	4.1	5.8	7.9	9.9	13.2	17.1	25.3	34.0	40.7	46.8	67.1	80.3	99.0	116.0	161.0	194.0
	Continuous (3x440-480 V) [A]	1.1	2.1	3.4	4.8	6.3	8.2	11.0	14.0	21.0	27.0	34.0	40.0	52.0	65.0	80.0	105.0	130.0	160.0
	Intermittent (3x440-480 V) [A]	1.2	2.3	3.7	5.3	6.9	9.0	12.1	15.4	23.1	29.7	37.4	44.0	57.2	71.5	88.0	115.0	143.0	176.0
<b>Max. input current</b>																			
	Continuous (3x380-440 V) [A]	1.2	2.1	3.5	4.7	6.3	8.3	11.2	15.1	22.1	29.9	35.2	41.5	57.0	70.0	84.0	103.0	140.0	166.0
	Intermittent (3x380-440 V) [A]	1.3	2.3	3.9	5.2	6.9	9.1	12.3	16.6	24.3	32.9	38.7	45.7	62.7	77.0	92.4	113.0	154.0	182.0
	Continuous (3x440-480 V) [A]	1.0	1.8	2.9	3.9	5.3	6.8	9.4	12.6	18.4	24.7	29.3	34.6	49.2	60.6	72.5	88.6	120.9	142.7
	Intermittent (3x440-480 V) [A]	1.1	2.0	3.2	4.3	5.8	7.5	10.3	13.9	20.2	27.2	32.2	38.1	54.1	66.7	79.8	97.5	132.9	157.0
See 1.3.6 Fuses																			
Max. mains fuses																			

Frequency converter	PK37	PK75	P1K5	P2K2	P3K0	P4K0	P5K5	P7K5	P11K	P15K	P18K	P22K	P30K	P37K	P45K	P55K	P75K	P90K	
Estimated power loss [W], Best case/typical <sup>1)</sup>	13/15	16/21	46/57	46/58	66/83	95/118	104/131	159/198	248/274	353/379	412/456	475/523	780	893	1160	1130	1460	1780	
Weight enclosure IP20 [kg]	2.0	2.0	2.1	3.3	3.3	3.4	4.3	4.5	7.9	7.9	9.5	9.5	24.5	24.5	24.5	36.0	36.0	51.0	
Efficiency [%], Best case/Typical 1	97.8/97.	98.0/97	97.7/97	98.3/97	98.2/97.	98.0/97.	98.4/98	98.2/9	98.1/9	98.0/9	98.1/9	98.1/9	97.8	97.9	97.1	98.3	98.3	98.3	
<b>Output current</b>																			
	<b>50°C ambient temperature</b>																		
Continuous (3x380-440 V) [A]	1.04	1.93	3.7	4.85	6.3	8.4	10.9	14.0	20.9	28.0	34.1	38.0	48.8	58.4	72.0	74.2	102.9	123.9	
Intermittent (3x380-440 V) [A]	1.1	2.1	4.07	5.4	6.9	9.2	12.0	15.4	23.0	30.8	37.5	41.8	53.7	64.2	79.2	81.6	113.2	136.3	
Continuous (3x440-480 V) [A]	1.0	1.8	3.4	4.4	5.5	7.5	10.0	12.6	19.1	24.0	31.3	35.0	41.6	52.0	64.0	73.5	91.0	112.0	
Intermittent (3x440-480 V) [A]	1.1	2.0	3.7	4.8	6.1	8.3	11.0	13.9	21.0	26.4	34.4	38.5	45.8	57.2	70.4	80.9	100.1	123.2	

## 1.8.2 EMC Test Results

The following test results have been obtained using a system with a frequency converter, a screened control cable, a control box with potentiometer, as well as a motor screened cable.

RFI Filter Type	Conduct emission. Maximum shielded cable length						Radiated emission			
	Industrial environment				Housing, trades and light industries		Industrial environment		Housing, trades and light industries	
	EN 55011 Class A2		EN 55011 Class A1		EN 55011 Class B		EN 55011 Class A1		EN 55011 Class B	
	Without external filter	With external filter	Without external filter [m]	With external filter [m]	Without external filter [m]	With external filter [m]	Without external filter	With external filter	Without external filter	With external filter
<b>H4 RFI filter (Class A1)</b>										
0.37-22 kW 3x380-480 V IP20			25	50		20	Yes	Yes		-
<b>H3 RFI filter (Class A1/B)</b>										
30-90 kW 3x380-480 V IP20			50		20		Yes		-	

### Protection and features

- Electronic thermal motor protection against overload.
- Temperature monitoring of the heatsink ensures that the frequency converter trips in case of overtemperature.
- The frequency converter is protected against short-circuits between motor terminals U, V, W.
- If a motor phase is missing, the frequency converter trips and issues an alarm.
- If a mains phase is missing, the frequency converter trips or issues a warning (depending on the load).
- Monitoring of the intermediate circuit voltage ensures that the frequency converter trips if the intermediate circuit voltage is too low or too high.
- The frequency converter is protected against earth faults on motor terminals U, V, W.

### Mains supply (L1, L2, L3)

Supply voltage	380-480 V ±10%
Supply frequency	50/60 Hz
Max. imbalance temporary between mains phases	3.0% of rated supply voltage
True Power Factor ( $\lambda$ )	≥0.9 nominal at rated load
Displacement Power Factor ( $\cos\phi$ ) near unity	(>0.98)
Switching on the input supply L1, L2, L3 (power-ups) enclosure frame H1-H5	Max. 2 times/min.
Switching on the input supply L1, L2, L3 (power-ups) enclosure frame H6-H8	Max. 1 time/min.
Environment according to EN 60664-1	overvoltage category III/pollution degree 2
The unit is suitable for use on a circuit capable of delivering not more than 100.000 RMS symmetrical Amperes, 240/480 V maximum.	

### Motor output (U, V, W)

Output voltage	0-100% of supply voltage
Output frequency	0-200 Hz (VVC <sup>plus</sup> ), 0-400 Hz (u/f)
Switching on output	Unlimited
Ramp times	0.05-3600 s

Cable lengths and cross sections

Max. motor cable length, screened/armoured (EMC correct installation)	See 1.8.2 EMC Test Results
Max. motor cable length, unscreened/unarmoured	50 m
Max. cross section to motor, mains*	
Cross section DC terminals for filter feedback on enclosure frame H1-H3, I2, I3	4 mm <sup>2</sup> /11 AWG
Cross section DC terminals for filter feedback on enclosure frame H4-H5	16 mm <sup>2</sup> /6 AWG
Maximum cross section to control terminals, rigid wire	2.5 mm <sup>2</sup> /14 AWG)
Maximum cross section to control terminals, flexible cable	2.5 mm <sup>2</sup> /14 AWG)
Minimum cross section to control terminals	0.05 mm <sup>2</sup> /30 AWG

\*See 1.8.1 Mains Supply 3x380-480 V AC for more information

Digital inputs:

Programmable digital inputs	4
Terminal number	18, 19, 27, 29
Logic	PNP or NPN
Voltage level	0-24 V DC
Voltage level, logic '0' PNP	<5 V DC
Voltage level, logic '1' PNP	>10 V DC
Voltage level, logic '0' NPN	>19 V DC
Voltage level, logic '1' NPN	<14 V DC
Maximum voltage on input	28 V DC
Input resistance, R <sub>i</sub>	Approx. 4 k
Digital input 29 as thermistor input	Fault: >2.9 kΩ and no fault: <800 Ω

Digital output

Programmable digital outputs	2
Terminal number	27, 29 <sup>1)</sup>
Voltage level at digital output	0-24 V DC
Max. output current (SINK or Source)	40 mA

1) Terminals 27 and 29 can also be programmed as digital inputs.

Analog inputs

Number of analog inputs	2
Terminal number	53, 54
Terminal 53 mode	Parameter 6-19: 1 = voltage, 0 = current
Terminal 54 mode	Parameter 6-29: 1 = voltage, 0 = current
Voltage level	0-10 V
Input resistance, R <sub>i</sub>	approx. 10 kΩ
Max. voltage	20 V
Current level	0/4 to 20 mA (scalable)
Input resistance, R <sub>i</sub>	<500 Ω
Max. current	29 mA

Analog output

Number of programmable analog outputs	2
Terminal number	42, 45 <sup>1)</sup>
Current range at analog output	0/4-20 mA
Max. load to common at analog output	500 Ω
Max. voltage at analog output	17 V
Accuracy on analog output	Max. error: 0.4 % of full scale
Resolution on analog output	10 bit

1) Terminal 42 and 45 can also be programmed as digital outputs.

<b>Digital output</b>	
Number of digital outputs	2
Terminal number	42, 45 <sup>1)</sup>
Voltage level at digital output (output current = 20 mA)	12 V DC
Max Voltage level at digital output (output current < 4 mA)	17 V DC
Max. output current	20 mA

<sup>1)</sup> Terminals 42 and 45 can also be programmed as analog outputs.

**Control card, RS-485 serial communication**

Terminal number	68 (P, TX+, RX+), 69 (N, TX-, RX-)
Terminal number	61 Common for terminals 68 and 69

**Control card, 24 V DC output**

Terminal number	12
Max. load enclosure frame H1-H8, I2-I8	80 mA

**Relay output**

<b>Programmable relay output</b>	
Relay 01 and 02	01-03 (NC), 01-02 (NO), 04-06 (NC), 04-05 (NO)
Max. terminal load (AC-1) <sup>1)</sup> on 01-02/04-05 (NO) (Resistive load)	250 V AC, 3 A
Max. terminal load (AC-15) <sup>1)</sup> on 01-02/04-05 (NO) (Inductive load @ cosφ 0.4)	250 V AC, 0.2 A
Max. terminal load (DC-1) <sup>1)</sup> on 01-02/04-05 (NO) (Resistive load)	30 V DC, 2 A
Max. terminal load (DC-13) <sup>1)</sup> on 01-02/04-05 (NO) (Inductive load)	24 V DC, 0.1 A
Max. terminal load (AC-1) <sup>1)</sup> on 01-03/04-06 (NC) (Resistive load)	250 V AC, 3 A
Max. terminal load (AC-15) <sup>1)</sup> on 01-03/04-06 (NC) (Inductive load @ cosφ 0.4)	250 V AC, 0.2 A
Max. terminal load (DC-1) <sup>1)</sup> on 01-03/04-06 (NC) (Resistive load)	30 V DC, 2 A
Min. terminal load on 01-03 (NC), 01-02 (NO) 24 V DC 10 mA, 24 V AC 20 mA	
Environment according to EN 60664-1	Overvoltage category III/pollution degree 2
1) IEC 60947 parts 4 and 5.	

**Control card, 10 V DC output**

Terminal number	50
Output voltage	10.5 V ±0.5 V
Max. load	25 mA

All inputs, outputs, circuits, DC supplies and relay contacts are galvanically isolated from the supply voltage (PELV) and other high-voltage terminals.

**Surroundings**

Enclosure	IP20
Enclosure kit available	IP21, TYPE 1
Vibration test	1.0 g
Max. relative humidity	5% - 95% (IEC 60721-3-3; Class 3K3 (non-condensing) during operation)
Aggressive environment (IEC 60721-3-3), coated (standard) frame H1-H5	Class 3C3
Aggressive environment (IEC 60721-3-3), non-coated frame H6-H10	Class 3C2
Aggressive environment (IEC 60721-3-3), coated (optional) frame H6-H10	Class 3C3
Test method according to IEC 60068-2-43 H2S (10 days)	
Ambient temperature	See max. output current at 40/50° C in the tables mains supply

Derating for high ambient temperature, see 1.8 *Special Conditions*

Minimum ambient temperature during full-scale operation	0° C
Minimum ambient temperature at reduced performance, enclosure frame H1-H5	-20° C
Minimum ambient temperature at reduced performance, enclosure frame H6-H10	-10° C
Temperature during storage/transport	-30 - +65/70° C
Maximum altitude above sea level without derating	1000 m
Maximum altitude above sea level with derating	3000 m

Derating for high altitude, see 1.8 *Special Conditions*

Safety standards	EN/IEC 61800-5-1, UL 508C
EMC standards, Emission	EN 61800-3, EN 61000-6-3/4, EN 55011, IEC 61800-3
EMC standards, Immunity	EN 61800-3, EN 61000-3-12, EN 61000-6-1/2, EN 61000-4-2, EN 61000-4-3, EN 61000-4-4, EN 61000-4-5, EN 61000-4-6

## 1.9 Special Conditions

### 1.9.1 Derating for Ambient Temperature and Switching Frequency

The ambient temperature measured over 24 hours should be at least 5°C lower than the max. ambient temperature. If the frequency converter is operated at high ambient temperature, the continuous output current should be decreased. For derating curve, see *Design Guide MG18C3YY*.

### 1.9.2 Derating for Low Air Pressure

The cooling capability of air is decreased at low air pressure. For altitudes above 2000 m, please contact Danfoss regarding PELV. Below 1000 m altitude no derating is necessary, but above 1000 m the ambient temperature or the maximum output current should be decreased. Decrease the output by 1% per 100 m altitude above 1000 m or reduce the max. ambient temperature by 1° per 200 m.





[www.danfoss.com/drives](http://www.danfoss.com/drives)

---

Danfoss can accept no responsibility for possible errors in catalogues, brochures and other printed material. Danfoss reserves the right to alter its products without notice. This also applies to products already on order provided that such alterations can be made without consequential changes being necessary in specifications already agreed. All trademarks in this material are property of the respective companies. Danfoss and the Danfoss logotype are trademarks of Danfoss A/S. All rights reserved.

---

