



# Quick Guide

## VLT<sup>®</sup> Compressor Drive CDS 803





## Contents

<b>1 Quick Guide</b>	<b>2</b>
1.1 Safety	2
1.1.1 Warnings	2
1.1.2 Safety Instructions	2
1.2 Introduction	3
1.2.1 Available Literature	3
1.2.2 Approvals	3
1.2.3 IT Line Power	3
1.2.4 Avoid Unintended Start	3
1.2.5 Disposal Instruction	3
1.3 Installation	4
1.3.1 Before Starting Repair Work	4
1.3.2 Enclosure Types	4
1.3.3 Side-by-Side Installation	4
1.3.4 Dimensions	5
1.3.6 Connecting to Line Power and Compressor	6
1.3.7 Fuses	8
1.3.8 EMC-compatible Electrical Installation	9
1.3.9 Control Terminals	10
1.4 Programming	12
1.4.2 The Start-up Wizard	13
1.4.3 Main Menu Structure	23
1.5 Acoustic Noise or Vibration	25
1.6 Warnings and Alarms	25
1.7 General Specifications	26
1.7.1 Line Power Supply 3x200–240 V AC	26
1.7.2 Line Power Supply 3x380–480 V AC	27
1.8 Special Conditions	31
1.8.1 Derating for Ambient Temperature and Switching Frequency	31
1.8.2 Derating for Low Air Pressure	31
1.9 Options for VLT <sup>®</sup> Compressor Drive CDS 803	31

# 1 Quick Guide

## 1.1 Safety

### 1.1.1 Warnings

#### **⚠️ WARNING**

##### High Voltage Warning

The voltage of the adjustable frequency drive is dangerous whenever it is connected to line power. Incorrect installation of the compressor or adjustable frequency drive may cause damage to the equipment, serious injury or death. Consequently, it is essential to comply with the instructions in this manual as well as local and national rules and safety regulations.

#### **⚠️ WARNING**

##### DISCHARGE TIME!

Adjustable frequency drives contain DC link capacitors that can remain charged even when the adjustable frequency drive is not powered. To avoid electrical hazards, disconnect AC line power, any permanent magnet type compressors, and any remote DC link power supplies, including battery backups, UPS, and DC link connections to other adjustable frequency drives. Wait for the capacitors to fully discharge before performing any service or repair work. The waiting time is listed in the Discharge Time table. Failure to wait for the specified period of time after power has been removed to do service or repair could result in death or serious injury.

Voltage [V]	Cooling capacity [TR]	Minimum waiting time (min)
3x200	4-6.5	15
3x400	4-5	4
3x400	6.5	15

Table 1.1 Discharge Time

#### **⚠️ CAUTION**

##### Leakage Current

The ground leakage current from the adjustable frequency drive exceeds 3.5 mA. According to IEC 61800-5-1, a reinforced protective ground connection must be ensured with a min. 10 mm<sup>2</sup> Cu or an additional PE wire - with the same cable cross-section as the line power wiring - must be terminated separately.

##### Residual Current Device

This product can cause a DC current in the protective conductor. Where a residual current device (RCD) is used for extra protection, only an RCD of Type B (time delayed) shall be used on the supply side of this product. See also *Danfoss Application Note on RCD, MN90G*.

Protective grounding of the adjustable frequency drive and the use of RCDs must always follow national and local regulations.

#### **⚠️ WARNING**

##### Installation at High Altitudes

For altitudes above 6,600 feet [2 km], contact Danfoss regarding PELV.

### 1.1.2 Safety Instructions

- Make sure the adjustable frequency drive is properly connected to ground.
- Do not remove AC line input connections, compressor connections or other power connections while the adjustable frequency drive is connected to power.
- Protect users against supply voltage.
- Protect the compressor against overloading according to national and local regulations.
- The ground leakage current exceeds 3.5 mA.
- The [Off/Reset] key is not a safety switch. It does not disconnect the adjustable frequency drive from line power.

## 1.2 Introduction

### 1.2.1 Available Literature

This Quick Guide contains basic information necessary for installing and running the adjustable frequency drive. Supplementary publications and manuals are available from Danfoss. See [www.danfoss.com/BusinessAreas/DrivesSolutions/ Documentations/VLT+Technical+Documentation.htm](http://www.danfoss.com/BusinessAreas/DrivesSolutions/Documentations/VLT+Technical+Documentation.htm) for listings.

### 1.2.2 Approvals



Certification		IP20
EC Declaration of Conformity		✓
UL-listed		✓
C-tick		✓

Table 1.2 Approvals

The adjustable frequency drive complies with UL508C thermal memory retention requirements. For more information, refer to the section *Motor Thermal Protection* in the *Design Guide*.

### 1.2.3 IT Line Power

#### **CAUTION**

##### IT Line Power

Installation on isolated line power source, that is, IT line power.

Max. supply voltage allowed when connected to line power: 440 V (3x380–480 V units).

Open the RFI switch by removing the screw on the side of the adjustable frequency drive when at IT grid.

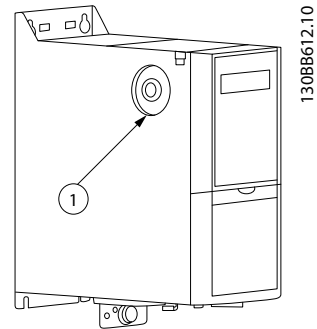

1	RFI switch
---	------------

Figure 1.1 IP20

#### **CAUTION**

If reinserted, only use M3x12 screws.

### 1.2.4 Avoid Unintended Start

While the adjustable frequency drive is connected to line power, the compressor can be started/stopped using digital commands, bus commands, references or via the LCP.

- Disconnect the adjustable frequency drive from line power whenever personal safety considerations make it necessary to avoid unintended start of any compressors.
- To avoid unintended start, always press [Off/Reset] before changing parameters.

### 1.2.5 Disposal Instruction

	<p>Equipment containing electrical components may not be disposed of together with domestic waste.</p> <p>It must be separately collected with electrical and electronic waste according to local and currently valid legislation.</p>
---	--

## 1.3 Installation

### 1.3.1 Before Starting Repair Work

1. Disconnect from line power (and external DC supply, if present).
2. Wait as stated in *Table 1.1* for discharge of the DC link.
3. Remove compressor cable.

### 1.3.2 Enclosure Types

Cooling capacity	400 V IP20
Enclosure	
4 TR/VZH028	H3
5 TR/VZH035	H3
6.5 TR/VZH044	H4

Table 1.3 H3-H4, 400 V

Cooling capacity	200 V IP20
Enclosure	
4 TR/VZH028	H4
5 TR/VZH035	H4
6.5 TR/VZH044	H5

Table 1.4 H4-H5, 200 V

### 1.3.3 Side-by-Side Installation

The adjustable frequency drive can be mounted side-by-side and requires the clearance above and below for cooling.

Frame	IP class	Clearance above/below mm/[inch]
H3	IP20	100/4
H4	IP20	100/4
H5	IP20	100/4

Table 1.5 Clearance

#### **NOTICE!**

With IP21/Nema Type1 option kit mounted, a distance of 2 in [50 mm] between the units is required.

### 1.3.4 Dimensions

#### **NOTICE!**

The figure in Table 1.6 is with LCP but all dimensions are the same without LCP.

Enclosure		Height (in [mm])			Width (in [mm])		Depth (in [mm])	Mounting hole (in [mm])			Max. Weight
Frame	IP Class	A	A <sup>1)</sup>	a	B	b	C	d	e	f	lb [kg]
H3	IP20	10 [255]	13 [329]	9.5 [240]	3.9 [100]	2.9 [74]	8.1 [206]	0.4 [11]	0.2 [5.5]	0.3 [8.1]	9.9 [4.5]
H4	IP20	11.7 [296]	14.1 [359]	10.8 [275]	5.3 [135]	4.1 [105]	9.5 [241]	0.5 [12.6]	0.3 [7]	0.33 [8.4]	17.4 [7.9]
H5	IP20	13.2 [334]	15.8 [402]	12.4 [314]	5.9 [150]	4.7 [120]	10 [255]	0.5 [12.6]	0.3 [7]	0.34 [8.5]	21 [9.5]

**Table 1.6 Dimensions**

1) Including decoupling plate

The dimensions are only for the physical units, but when installing in an application it is necessary to add space for free air passage both above and below the units. The amount of space for free air passage is listed in Table 1.5.

### 1.3.5 Electrical Installation in General

All cabling must comply with national and local regulations on cable cross-sections and ambient temperature. Copper conductors required, (167 °F [75 °C]) recommended.

Enclosure		Torque [Nm]					
Frame	IP class	Line	Compressor connection	DC connection	Control terminals	Ground	Relay
H3	IP20	1.4	0.8	0.8	0.5	0.8	0.5
H4	IP20	1.2	1.2	1.2	0.5	0.8	0.5
H5	IP20	1.2	1.2	1.2	0.5	0.8	0.5

**Table 1.7 Enclosure H3-H5**

### 1.3.6 Connecting to Line Power and Compressor

The adjustable frequency drive is designed to operate Danfoss VZH Compressors. For the maximum cross-section on wires, see *chapter 1.7 General Specifications*.

- Use a shielded/armored compressor cable to comply with EMC emission specifications, and connect this cable to both the decoupling plate and the compressor metal.
  - Keep compressor cable as short as possible to reduce the noise level and leakage currents.
  - For further details on mounting of the decoupling plate, see *VLT® Compressor Drive CDS 803 Decoupling Plate Installation Instructions*.
  - Also see *EMC-compatible Installation in the VLT® Compressor Drive CDS 803 Design Guide*.
1. Mount the ground wires to ground terminal.
  2. Connect compressor to terminals U, V and W, see *Table 1.8*.

U	T1
V	T2
W	T3

Table 1.8 Connection of Compressor to Terminals

3. Mount line power supply to terminals L1, L2 and L3 and tighten.

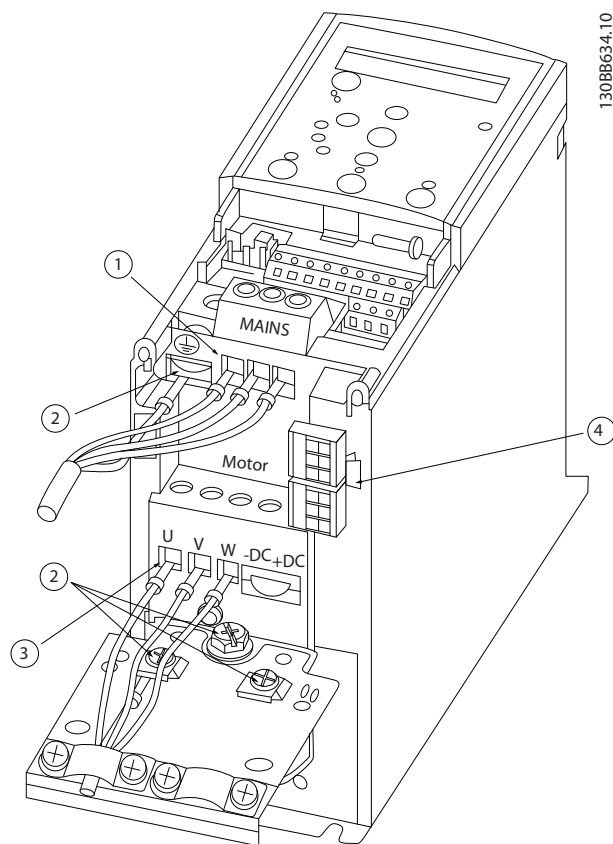

1	Line
2	Ground
3	Compressor
4	Relays

Figure 1.2 H3-H5 Frame  
 IP20 200–240 V 4–6.5 tons  
 IP20 380–480 V 4–6.5 tons



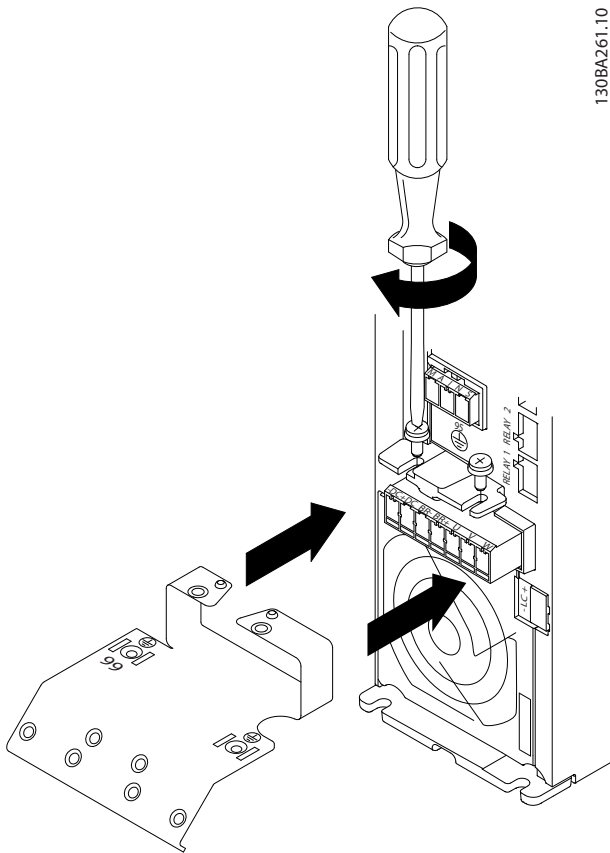

Figure 1.3 Mount the two screws in the mounting plate, slide it into place and tighten fully

130BA261.10

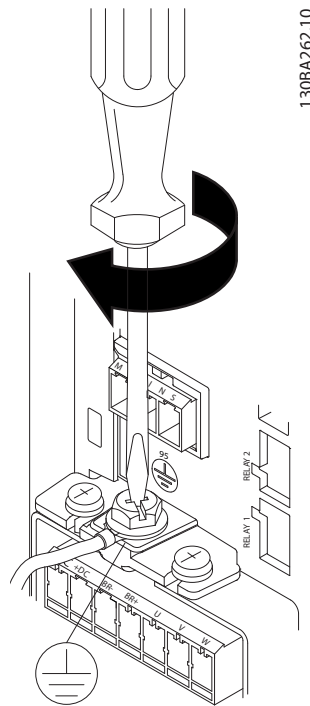

Figure 1.5 When mounting cables, first mount and tighten ground cable

130BA262.10

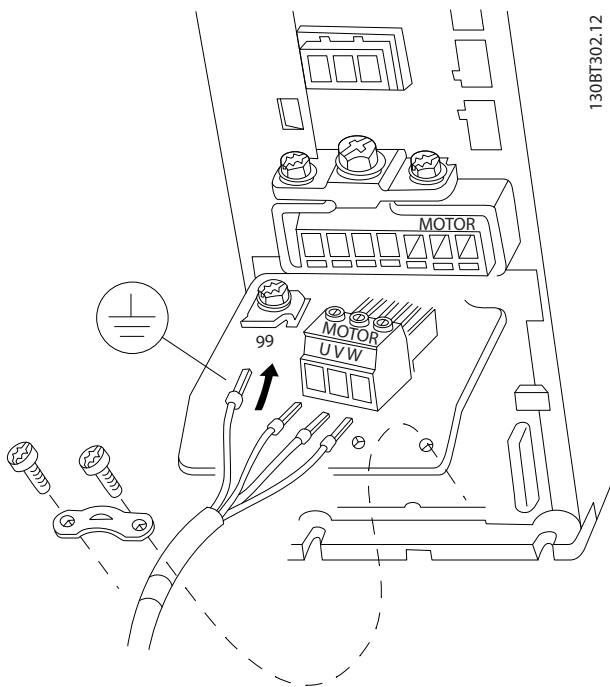

Figure 1.4 H3-H5 Frame

130BT302.12

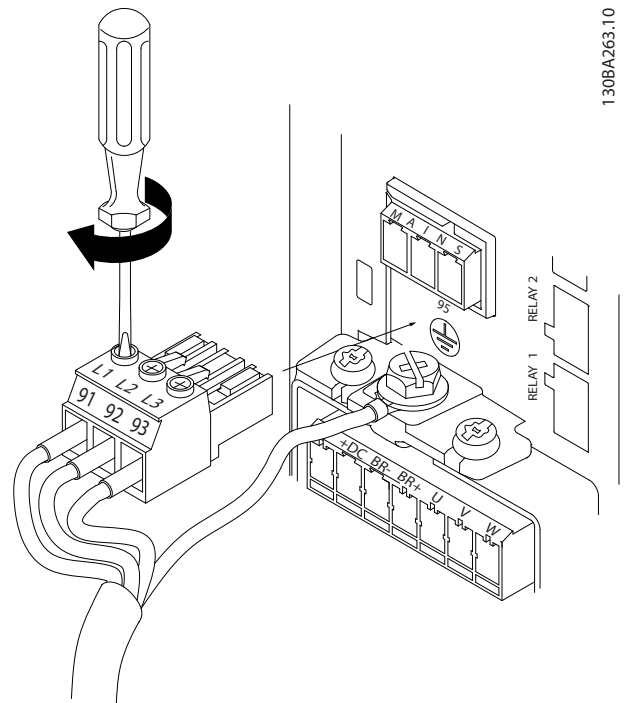

Figure 1.6 Mount line power plug and tighten wires

130BA263.10

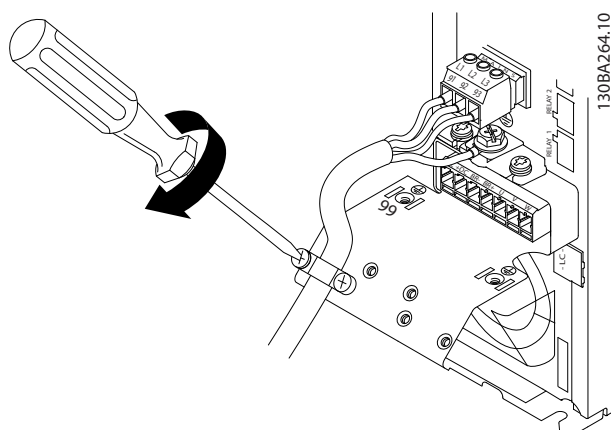

Figure 1.7 Tighten support bracket on line power wires

### 1.3.7 Fuses

#### Branch circuit protection

To protect the installation against electrical and fire hazard, all branch circuits in an installation, switch gear, machines, etc., must be short-circuit and overcurrent protected according to national and local regulations.

#### Short circuit protection

Danfoss recommends using the fuses listed in *Table 1.9* to protect service personnel or equipment in case of an internal failure in the unit or short circuit on the DC link. The adjustable frequency drive provides full short circuit protection in case of a short circuit on the compressor.

#### Overcurrent protection

Provide overload protection to avoid overheating of the cables in the installation. Overcurrent protection must always be carried out according to local and national regulations. Circuit breakers and fuses must be designed for protection in a circuit capable of supplying a maximum of 100,000  $A_{rms}$  (symmetrical), 480 V maximum.

#### UL/Non-UL compliance

Use the fuses listed in *Table 1.9* to ensure compliance with UL or IEC 61800-5-1.

#### **NOTICE!**

In the event of malfunction, failure to follow the protection recommendation may result in damage to the adjustable frequency drive.

	Fuse				
	UL				Non-UL
	Bussmann	Bussmann	Bussmann	Bussmann	Max fuse
CDS 803	Type RK5	Type RK1	Type J	Type T	Type G
<b>3x200–240 V IP20</b>					
4 TR/VZH028	FRS-R-50	KTN-R50	JKS-50	JJN-50	50
5 TR/VZH035	FRS-R-50	KTN-R50	JKS-50	JJN-50	50
6.5 TR/VZH044	FRS-R-80	KTN-R80	JKS-80	JJN-80	65
<b>3x380–480 V IP20</b>					
4 TR/VZH028	FRS-R-25	KTS-R25	JKS-25	JJS-25	25
5 TR/VZH035	FRS-R-25	KTS-R25	JKS-25	JJS-25	25
6.5 TR/VZH044	FRS-R-50	KTS-R50	JKS-50	JJS-50	50

Table 1.9 Fuses

### 1.3.8 EMC-compatible Electrical Installation

General points to be observed to ensure EMC-compatible electrical installation.

- Use only shielded/armored motor cables and shielded/armored control cables.
- Connect the shield to ground at both ends.
- Avoid installation with twisted shield ends (pigtailed), since this ruins the shielding effect at high frequencies. Use the cable clamps provided instead.
- Ensure the same potential between adjustable frequency drive and ground potential of PLC.
- Use starwashers and galvanically grounding plates.

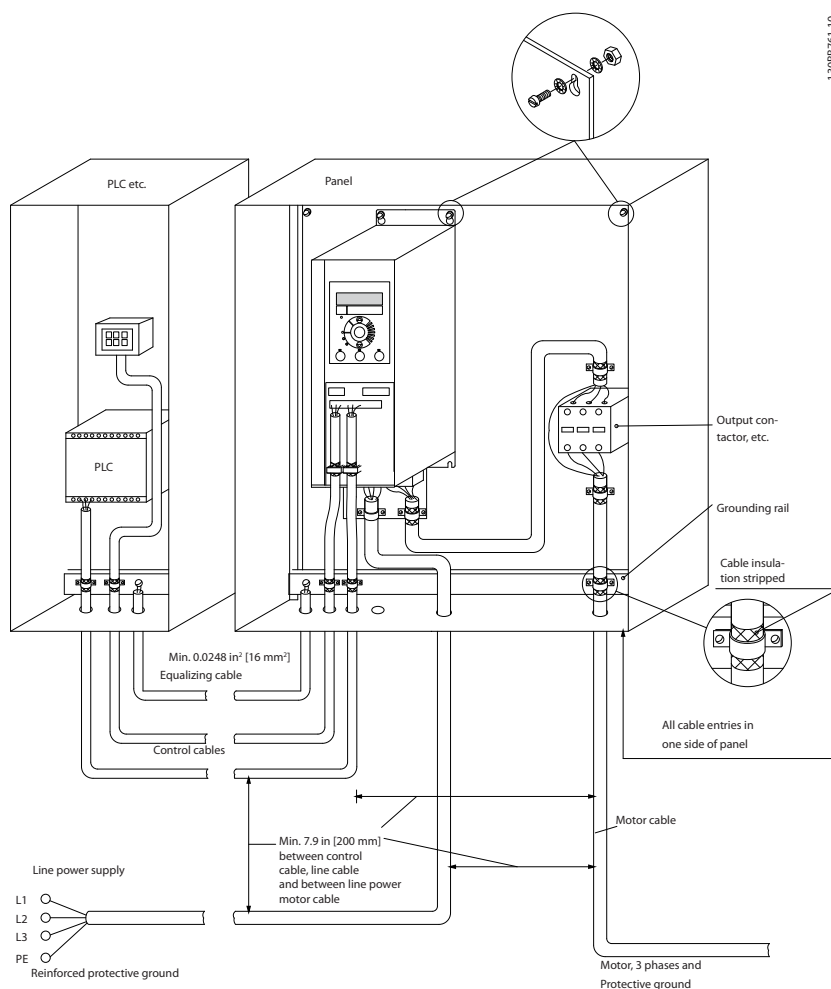

Figure 1.8 EMC-compatible Electrical Installation

For North America, use metal conduits instead of shielded cables.

### 1.3.9 Control Terminals

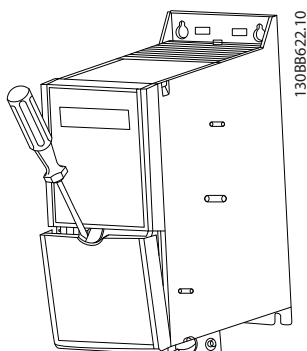

Figure 1.9 Location of Control Terminals

1. Place a screwdriver behind the terminal cover to activate the snap.
2. Tilt the screwdriver outwards to open the cover.

#### Control terminals

To make the compressor run:

1. Apply start signal on terminal 18.
2. Connect terminals 12, 27 and terminal 53, 54 or 55

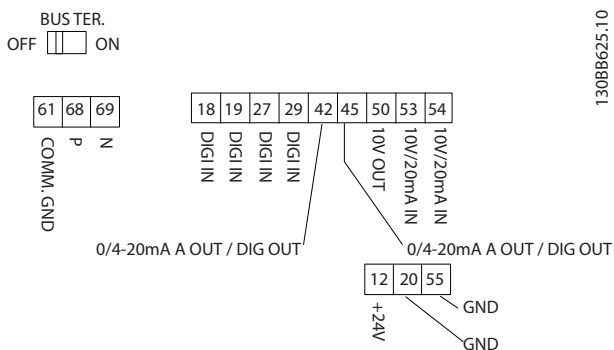

Figure 1.10 Control Terminals

Set the functions of digital input 18, 19 and 27 in *5-00 Digital Input Mode* (PNP is default value). Set the function of digital input 29 in *5-03 Digital Input 29 Mode* (PNP is default value).

1.3.10 Electrical Overview

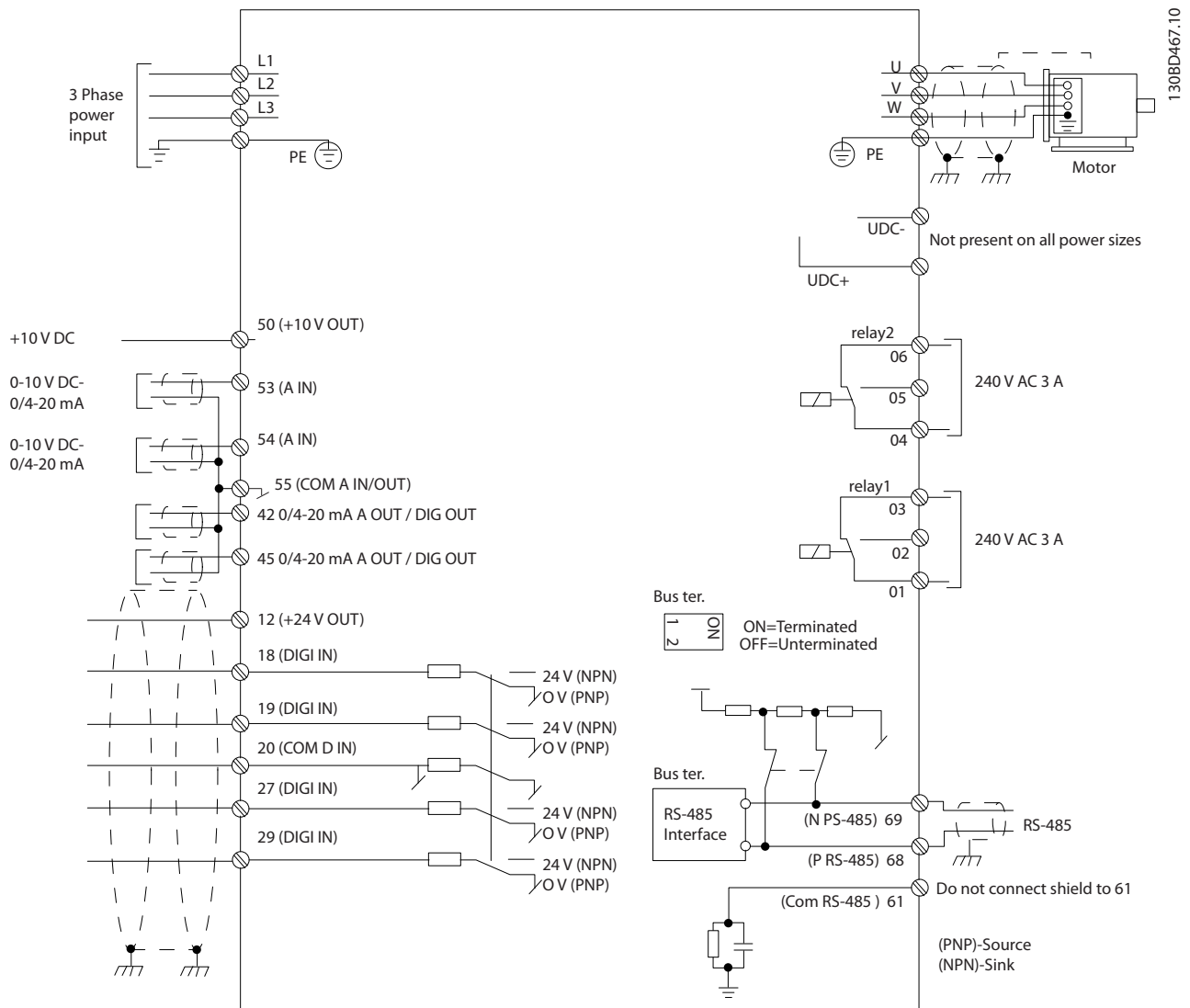

Figure 1.11 Basic Wiring Schematic Drawing

## 1.4 Programming

### 1.4.1 Local Control Panel (LCP)

**NOTICE!**

LCP is NOT supported in SW 1.0X!

The LCP is divided into four functional sections.

- A. Display
- B. Menu key
- C. Navigation keys and LEDs
- D. Operation keys and LEDs

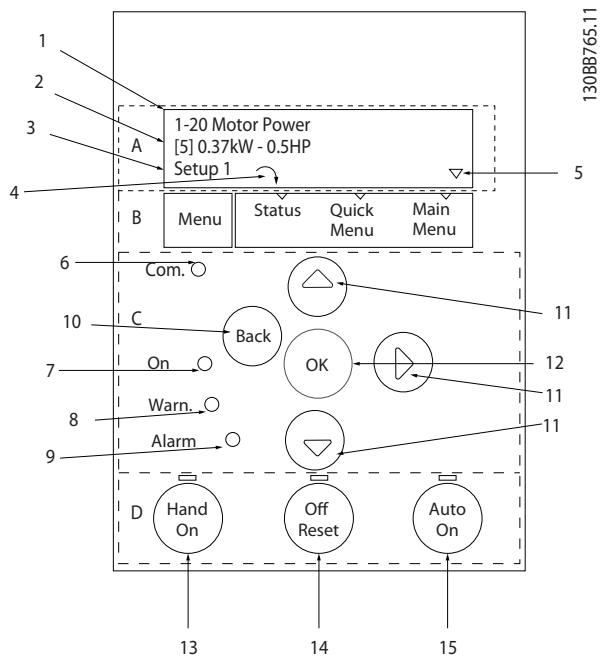

Figure 1.12 Local Control Panel (LCP)

#### A. Display

The LCD display is backlit with two alphanumeric lines. All data is displayed on the LCP.

Information can be read from the display.

1	Parameter number and name.
2	Parameter value.
3	Set-up number shows the active set-up and the edit set-up. If the same set-up acts as both the active and edit set-up, only that set-up number is shown (factory setting). When active and edit set-ups differ, both numbers are shown in the display (Set-up 12). The flashing number indicates the edit set-up.
4	Compressor direction is shown to the bottom left of the display – indicated by a small arrow pointing either clockwise or counter-clockwise.
5	The triangle indicates if the LCP is in Status, Quick Menu or Main Menu.

Table 1.10 Legend to Figure 1.12

#### B. Menu key

Press [Menu] to select between Status, Quick Menu or Main Menu.

#### C. Navigation keys and LEDs

6	Com LED: Flashes when bus communication is communicating.
7	Green LED/On: Control section is working.
8	Yellow LED/Warn.: Indicates a warning.
9	Flashing Red LED/Alarm: Indicates an alarm.
10	[Back]: For moving to the previous step or layer in the navigation structure
11	[▲] [▼] [▶]: For navigating between parameter groups, parameters and within parameters. Can also be used for setting local reference.
12	[OK]: For selecting a parameter and for accepting changes to parameter settings

Table 1.11 Legend to Figure 1.12

D. Operation keys and LEDs

13	<p>[Hand On]: Starts the compressor and enables control of the adjustable frequency drive via the LCP.</p> <p><b>NOTICE!</b></p> <p><b>Terminal 27 Digital Input (5-12 Terminal 27 Digital Input) has stop inverse as default setting. This means that [Hand On] does not start the compressor if there is no 24 V to terminal 27. Connect terminal 12 to terminal 27.</b></p>
14	<p>[Off/Reset]: Stops the compressor (Off). If in alarm mode, the alarm is reset.</p>
15	<p>[Auto On]: The adjustable frequency drive is controlled either via control terminals or serial communication.</p>

The wizard is initially be shown after power-up until any parameter has been changed. The wizard can always be accessed again through the Quick Menu. Press [OK] to start the wizard. Press [Back] to return to the status screen.

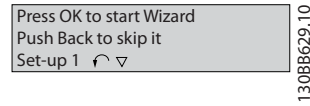

Figure 1.14 Start-up/Quit Wizard

Table 1.12 Legend to Figure 1.12

1.4.2 The Start-up Wizard

The built-in wizard menu guides the installer through the set-up of the adjustable frequency drive in a clear and structured manner to set up an open-loop application. An open-loop application is here an application with a start signal, analog reference (voltage or current) and optionally also relay signals (but no feedback signal from the process applied).

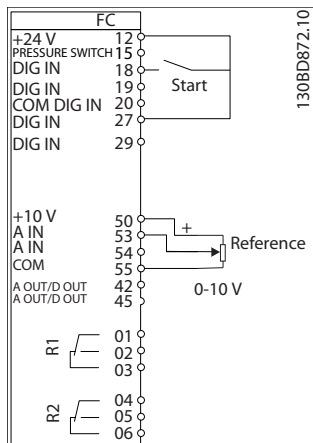
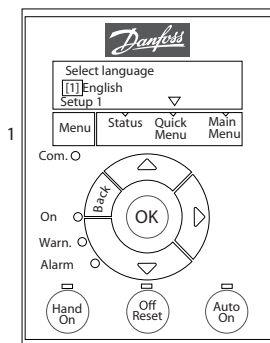

Figure 1.13 Open-loop Application

At power up the user is asked to choose the preferred language.



Power Up Screen



The next screen will be the Wizard screen.

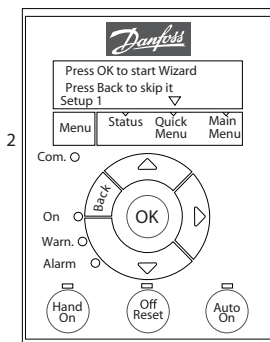

Wizard Screen

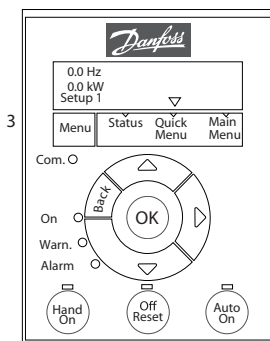

Status Screen

The Wizard can always be reentered via the Quick Menu!

... the CDS 803 Wizard starts

- 4 Select Language  
[0] English  
Setup 1 ▼
- 5 Select Grid Type  
Size related  
Setup 1 ▼
- 6 Select Main Menu Password  
[0] Setup 1 ▼
- 7 Select Compressor Selection  
Size related  
Setup 1 ▼
- 8 Select Max. reference  
200 Hz  
Setup 1 ▼
- 9 Select Reference 1 Source  
[1] Analog in 53  
Setup 1 ▼
- 10 Select Ramp 1 Ramp Up Time  
30 s  
Setup 1 ▼
- 11 Select Ramp 1 Ramp Down Time  
30 s  
Setup 1 ▼
- 12 Select Terminal 27 Digital In  
[6] Stop inverse  
Setup 1 ▼
- 13 Select Relay 1  
[9] Alarm  
Setup 1 ▼
- 14 Select Relay 2  
[5] Drive Running  
Setup 1 ▼
- 15 Select Terminal 53 Low Voltage  
0.07 V  
Setup 1 ▼
- 16 Select Terminal 53 High Voltage  
10 V  
Setup 1 ▼
- 17 Select Control Site  
[0] Digital and ctrl.word  
Setup 1 ▼
- 18 Select Protocol  
[0] FC  
Setup 1 ▼
- 19 Select Address  
1  
Setup 1 ▼





**The Start-up Wizard for open-loop applications**

Parameter	Option	Default	Function
0-01 Language	[0] English [1] Deutsch [2] Francais [3] Dansk [4] Spanish [5] Italiano [28] Bras.port	[0] English	Select the language for the display.
0-06 GridType	[0] 200–240 V/50 Hz/IT grid [1] 200–240 V/50 Hz/Delta [2] 200–240 V/50 Hz [10] 380–440 V/50 Hz/IT grid [11] 380–440 V/50 Hz/Delta [12] 380–440 V/50 Hz [20] 440–480 V/50 Hz/IT grid [21] 440–480 V/50 Hz/Delta [22] 440–480 V/50 Hz [30] 525–600 V/50 Hz/IT grid [31] 525–600 V/50 Hz/Delta [32] 525–600 V/50 Hz [100] 200–240 V/60 Hz/IT grid [101] 200–240 V/60 Hz/Delta [102] 200–240 V/60 Hz [110] 380–440 V/60 Hz/IT grid [111] 380–440 V/60 Hz/Delta [112] 380–440 V/60 Hz [120] 440–480 V/60 Hz/IT grid [121] 440–480 V/60 Hz/Delta [122] 440–480 V/60 Hz [130] 525–600 V/60 Hz/IT grid [131] 525–600 V/60 Hz/Delta [132] 525–600 V/60 Hz	Size related	Select operating mode for restart upon reconnection of the adjustable frequency drive to AC line voltage after power-down.
0-60 Main Menu Password	0–999	0	Define the password for access to the LCP.
1-13 Compressor Selection	[24] VZH028-R410A [25] VZH035-R410A [26] VZH044-R410A	Size related	Select the used compressor.
3-03 Maximum Reference	0–200 Hz	200 Hz	The maximum reference is the lowest obtainable by summing all references.
3-15 Reference 1 Source	[0] No function [1] Analog in 53 [2] Analog in 54 [7] Pulse input 29 [11] Local bus reference	[1] Analog in 53	Select the input to be used for the reference signal.
3-41 Ramp 1 Ramp Up Time	0.05–3600.0 s	30.00 s	Ramp-up time from 0 to 1-25 Motor Nominal Speed.
3-42 Ramp 1 Ramp Down Time	0.05–3600.0 s	30.00 s	Ramp-down time from rated motor speed to 0.

Parameter	Option	Default	Function
5-12 Terminal 27 Digital Input	[0] No operation [1] Reset [2] Coast inverse [3] Coast and reset inverse [4] Quick stop inverse [5] DC brake inverse [6] Stop inverse [7] External Interlock [8] Start [9] Latched start [10] Reversing [11] Start reversing [14] Jog [16] Preset ref bit 0 [17] Preset ref bit 1 [18] Preset ref bit 2 [19] Freeze reference [20] Speed up [22] Slow [23] Set-up select bit 0 [34] Ramp bit 0 [52] Run permissive [53] Hand start [54] Auto-start [60] Counter A (up) [61] Counter A (down) [62] Reset Counter A [63] Counter B (up) [64] Counter B (down) [65] Reset Counter B	[6] Stop inverse	Select the input function for terminal 27.
5-40 Function Relay [0] Function relay	See 5-40 Function Relay	Alarm	Select the function to control output relay 1.
5-40 Function Relay [1] Function relay	See 5-40 Function Relay	Drive running	Select the function to control output relay 2.
6-10 Terminal 53 Low Voltage	0–10 V	0.07 V	Enter the voltage that corresponds to the low reference value.
6-11 Terminal 53 High Voltage	0–10 V	10 V	Enter the voltage that corresponds to the high reference value.
8-01 Control Site	[0] Digital and ctrl.word [1] Digital only [2] Controlword only	[0] Digital and ctrl. word	Select if digital, bus, or a combination of both should control the adjustable frequency drive.
8-30 Protocol	[0] FC [2] Modbus RTU	[0] FC	Select the protocol for the integrated RS-485 port.
8-32 Baud Rate	[0] 2,400 Baud [1] 4,800 Baud *[2] 9,600 Baud [3] 19,200 Baud 4) 38,400 Baud 5) 57,600 Baud [6] 76,800 Baud [7] 115,200 Baud	9600	Select the baud rate for the RS-485 port.

Table 1.13 Open-loop Applications Set-up

The Start-up Wizard for compressor functions

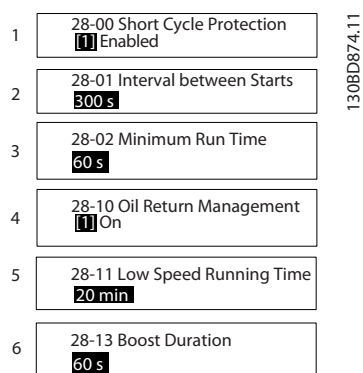

Figure 1.16 Compressor Function Wizard

Compressor function wizard

Parameter	Option	Default	Function
28-00 Short Cycle Protection	[0] Disabled [1] Enabled	[1] Enabled	Select if short cycle protection is to be used.
28-01 Interval between Starts	0–3600 s	300 s	Enter the minimum allowed time between starts.
28-02 Minimum Run Time	10–3600 s	60 s	Enter the minimum allowed time to run before stop.
28-10 Oil Return Management	[0] Off [1] On	[1] On	Select if Oil Return Management is to be used.
28-11 Low Speed Running Time	1–1400 min	20 min	Enter the low speed running time.
28-13 Boost Duration	10–3600 s	60 s	Enter the boost duration for the oil return.

Table 1.14 Compressor Function

The Start-up Wizard for compressor closed-loop applications

1	0-01 Language <input type="text" value="0"/> English
2	0-06 Grid Type <input type="text" value="Size related"/>
3	0-60 Main Menu Password <input type="text" value="0"/>
4	1-00 Configuration Mode <input type="text" value="0"/> Size related
5	1-13 Compressor Selection <input type="text" value="1"/> Closed loop
6	3-02 Minimum Reference <input type="text" value="0"/> Hz
7	3-03 Maximum Reference <input type="text" value="200"/> Hz
8	3-10 Preset Reference <input type="text" value="0%"/>
9	3-15 Reference 1 Source <input type="text" value="1"/> Analog in 53
10	3-41 Ramp 1 Ramp Up Time <input type="text" value="30.00"/> s
11	3-42 Ramp 1 Ramp Down Time <input type="text" value="30.00"/> s
12	5-12 Terminal 27 Digital Input <input type="text" value="6"/> Stop inverse
13	5-40 Function Relay 1 Alarm
14	5-40 Function Relay 2 Drive running
15	6-10 Terminal 53 Low Voltage <input type="text" value="0.07"/> V
16	6-11 Terminal 53 High Voltage <input type="text" value="10"/> V
17	6-14 Terminal 53 Low Ref./Feedb. <input type="text" value="30.000"/> Hz
18	6-15 Terminal 53 High Ref./Feedb. <input type="text" value="200.000"/> Hz
19	6-22 Terminal 54 Low Current <input type="text" value="4.00"/> mA
20	6-23 Terminal 54 High Current <input type="text" value="20.00"/> mA
21	6-24 Terminal 54 Low Ref./Feedb. <input type="text" value="0.000"/>
22	6-25 Terminal 54 High Ref./Feedb. <input type="text" value="4999.000"/>
23	20-00 Feedback 1 Source <input type="text" value="2"/> Analog input 54
24	20-04 Feedback 2 Conversion <input type="text" value="0"/> Linear
25	8-01 Control Site <input type="text" value="0"/> Digital and ctrl.word
26	8-30 Protocol <input type="text" value="0"/> FC
27	8-31 Address <input type="text" value="1"/>

1308D0751.2

Figure 1.17 Closed-loop Wizard

## Closed-loop wizard

Parameter	Option	Default	Function
0-01 Language	[0] English [1] Deutsch [2] Francais [3] Dansk [4] Spanish [5] Italiano [28] Bras.port	0	Select the language for the display.
0-06 GridType	[0] 200–240 V/50 Hz/IT grid [1] 200–240 V/50 Hz/Delta [2] 200–240 V/50 Hz [10] 380–440 V/50 Hz/IT grid [11] 380–440 V/50 Hz/Delta [12] 380–440 V/50 Hz [20] 440–480 V/50 Hz/IT grid [21] 440–480 V/50 Hz/Delta [22] 440–480 V/50 Hz [30] 525–600 V/50 Hz/IT grid [31] 525–600 V/50 Hz/Delta [32] 525–600 V/50 Hz [100] 200–240 V/60 Hz/IT grid [101] 200–240 V/60 Hz/Delta [102] 200–240 V/60 Hz [110] 380–440 V/60 Hz/IT grid [111] 380–440 V/60 Hz/Delta [112] 380–440 V/60 Hz [120] 440–480 V/60 Hz/IT grid [121] 440–480 V/60 Hz/Delta [122] 440–480 V/60 Hz [130] 525–600 V/60 Hz/IT grid [131] 525–600 V/60 Hz/Delta [132] 525–600 V/60 Hz	Size related	Select the operating mode for restart upon reconnection of the adjustable frequency drive to AC line voltage after power-down.
0-60 Main Menu Password	0–999	0	Define the password for access to the LCP.
1-00 Configuration Mode	[0] Open-loop [3] Closed-loop	[0] Open-loop	Select closed-loop.
1-13 Compressor Selection	[24] VZH028-R410A [25] VZH035-R410A [26] VZH044-R410A	Size related	Select the used compressor.
3-02 Minimum Reference	-4999.0–200 Hz	0 Hz	The minimum reference is the lowest value obtainable by summing all references.
3-03 Maximum Reference	0–200 Hz	200 Hz	The maximum reference is the highest obtainable by summing all references
3-10 Preset Reference	-100–100%	0%	Set up a fix setpoint n preset reference [0].
3-15 Reference 1 Source	[0] No function [1] Analog in 53 [2] Analog in 54 [7] Pulse input 29 [11] Local bus reference	[1] Analog in 53	Select the input to be used for the reference signal.
3-41 Ramp 1 Ramp Up Time	0.05–3600.0 s	30.00 s	Ramp-up time from 0 to 1-25 Motor Nominal Speed.
3-42 Ramp 1 Ramp Down Time	0.05–3600.0 s	30.00 s	Ramp-down time from rated motor speed to 0.

Parameter	Option	Default	Function
5-12 Terminal 27 Digital Input	[0] No operation [1] Reset [2] Coast inverse [3] Coast and reset inverse [4] Quick stop inverse [5] DC brake inverse [6] Stop inverse [7] External Interlock [8] Start [9] Latched start [10] Reversing [11] Start reversing [14] Jog [16] Preset ref bit 0 [17] Preset ref bit 1 [18] Preset ref bit 2 [19] Freeze reference [20] Speed up [22] Slow [23] Set-up select bit 0 [34] Ramp bit 0 [52] Run permissive [53] Hand start [54] Auto-start [60] Counter A (up) [61] Counter A (down) [62] Reset Counter A [63] Counter B (up) [64] Counter B (down) [65] Reset Counter B	[6] Stop inverse	Select the input function for terminal 27.
5-40 Function Relay [0] Function relay	See 5-40 Function Relay	Alarm	Select the function to control output relay 1.
5-40 Function Relay [1] Function relay	See 5-40 Function Relay	Drive running	Select the function to control output relay 2.
6-10 Terminal 53 Low Voltage	0–10 V	0.07 V	Enter the voltage that corresponds to the low reference value.
6-11 Terminal 53 High Voltage	0–10 V	10 V	Enter the voltage that corresponds to the high reference value.
6-14 Terminal 53 Low Ref./Feedb. Value	-4999–4999	30	Enter the reference value that corresponds to the voltage set in 6-10 Terminal 53 Low Voltage.
6-15 Terminal 53 High Ref./Feedb. Value	-4999–4999	200	Enter the reference value that corresponds to the voltage set in 6-11 Terminal 53 High Voltage.
6-22 Terminal 54 Low Current	0.00–20.00 mA	4.00 mA	Enter the current that corresponds to the low reference value.
6-23 Terminal 54 High Current	0–10 V	10 V	Enter the current that corresponds to the high reference value.
6-24 Terminal 54 Low Ref./Feedb. Value	-0.00–20.00 mA	20.00 mA	Enter the reference value that corresponds to the current set in 6-20 Terminal 54 Low Voltage.
6-25 Terminal 54 High Ref./Feedb. Value	-4999–4999	Size related	Enter the reference value that corresponds to the current set in 6-21 Terminal 54 High Voltage.

Parameter	Option	Default	Function
8-01 Control Site	[0] Digital and ctrl.word [1] Digital only [2] Controlword only	[0] Digital and ctrl.word	Select if digital, bus, or a combination of both should control the adjustable frequency drive.
8-30 Protocol	[0] FC [2] Modbus RTU	[0] FC	Select the protocol for the integrated RS-485 port.
8-32 Baud Rate	[0] 2,400 Baud [1] 4,800 Baud [2] 9,600 Baud [3] 19,200 Baud [4] 38,400 Baud [5] 57,600 Baud [6] 76,800 Baud [7] 115,200 Baud	[2] 9,600 Baud	Select the baud rate for the RS-485 port.
20-00 Feedback 1 Source	[0] No function [1] Analog Input 53 [2] Analog Input 54 [3] Pulse input 29 [100] Bus Feedback 1 [101] Bus Feedback 2	[0] No function	Select which input will be used as the source of the feedback signal.
20-01 Feedback 1 Conversion	[0] Linear [1] Square root	[0] Linear	Select how the feedback should be calculated

Table 1.15 Closed-loop Applications Set-up

**Changes made**

*Changes Made* lists all parameters changed from default settings.

- The list shows only parameters which have been changed in the current edit set-up.
- Parameters which have been reset to default values are not listed.
- The message *Empty* indicates that no parameters have been changed.

**To change parameter settings**

1. Press [Menu] key to enter the Quick Menu until indicator in display is placed above Quick Menu.
2. Press [▲] [▼] to select wizard, closed-loop set-up, compressor set-up or changes made, then press [OK].
3. Press [▲] [▼] to browse through the parameters in the Quick Menu.
4. Press [OK] to select a parameter.
5. Press [▲] [▼] to change the value of a parameter setting.
6. Press [OK] to accept the change.
7. Press either [Back] twice to enter Status, or press [Menu] once to enter Main Menu.

**The Main Menu accesses all parameters**

1. Press [Menu] until indicator in display is placed above Main Menu.
2. Press [▲] [▼] to browse through the parameter groups.
3. Press [OK] to select a parameter group.
4. Press [▲] [▼] to browse through the parameters in the specific group.
5. Press [OK] to select the parameter.
6. Press [▲] [▼] to set/change the parameter value.



## Quick Guide

## Quick Guide

Code	Parameter Name	Value	Parameter Name	Value	File Name
1.4.3	Main Menu Structure				
0-0*	Operation / Display		13-11	Comparator Operator	15-59
0-0*	Basic Settings		13-12	Comparator Value	15-9* Parameter Info
0-01	Language		13-20	Timers	15-92 Defined Parameters
0-03	Regional Settings		13-20	SL Controller Timer	15-97 Application Type
0-04	Operating State at Power-up		13-4*	Logic Rules	15-98 Drive Identification
0-06	GridType		13-40	Logic Rule Boolean 1	16-0* Data Readouts
0-07	Auto DC Braking		13-41	Logic Rule Operator 1	16-0* General Status
0-1*	Set-up Operations		13-42	Logic Rule Boolean 2	16-00 Control Word
0-10	Active Set-up		13-43	Logic Rule Operator 2	16-01 Reference [Unit]
0-11	Programming Set-up		13-44	Logic Rule Boolean 3	16-02 Reference [%]
0-12	Link Setups		13-5*	States	16-03 Status Word
0-3*	LCP Custom Readout		13-51	SL Controller Event	16-05 Main Actual Value [%]
0-30	Custom Readout Unit		13-52	SL Controller Action	16-09 Custom Readout
0-31	Custom Readout Min Value		14-0*	Special Functions	16-1* Motor Status
0-32	Custom Readout Max Value		14-01	Inverter Switching	16-10 Power [kW]
0-4*	LCP Keypad		14-01	Switching Frequency	16-11 Power [hp]
0-40	[Hand on] Key on LCP		14-03	Overmodulation	16-12 Motor Voltage
0-42	[Auto on] Key on LCP		14-1*	Mains On/Off	16-13 Frequency
0-44	[Off/Reset] Key on LCP		14-12	Function at Mains Imbalance	16-14 Motor current
0-5*	Copy/Save		14-2*	Reset Functions	16-15 Frequency [%]
0-50	LCP Copy		14-20	Reset Mode	16-16 Torque [Nm]
0-51	Set-up Copy		14-21	Automatic Restart Time	16-18 Motor Thermal
0-6*	Password		14-22	Operation Mode	16-22 Torque [%]
0-60	Main Menu Password		14-23	Typecode Setting	16-3* Drive Status
1-1*	Load and Motor		14-29	Service Code	16-30 DC Link Voltage
1-1*	Motor Selection		14-5*	Environment	16-34 Heatsink Temp.
1-10	Motor Construction		14-50	RFI Filter	16-35 Inverter Thermal
1-13	Compressor Selection		14-6*	Auto Derate	16-36 Inv. Nom. Current
1-9*	Motor Temperature		14-65	Speed Derate Dead Time Compensation	16-37 Inv. Max. Current
1-90	Motor Thermal Protection		14-9*	Fault Settings	16-38 SL Controller State
1-93	Thermistor Source		14-90	Fault Level	16-5* Ref. & Feedb.
1-9*	Motor Temperature		14-90	PCD Read Configuration	16-50 External Reference
3-3**	Reference / Ramps		15-0*	Drive Information	16-52 Feedback[Unit]
3-0*	Reference Limits		15-00	Operating hours	16-54 Feedback 1 [Unit]
3-02	Minimum Reference		15-01	Running Hours	16-55 Feedback 2 [Unit]
3-03	Maximum Reference		15-03	Power Up's	16-6* Inputs & Outputs
3-1	References		15-04	Over Temp's	16-60 Digital Input
3-10	Preset Reference		15-05	Over Volt's	16-61 Terminal 53 Setting
3-11	Jog Speed [Hz]		15-06	Reset kWh Counter	16-62 Analog Input AI53
3-14	Preset Relative Reference		15-07	Reset Running Hours Counter	16-63 Terminal 54 Setting
3-15	Reference 1 Source		15-08	Number of Starts	16-64 Analog Input AO42 [mA]
3-16	Reference 2 Source		15-09	Number of Auto Resets	16-65 Analog Output
3-17	Reference 3 Source		15-3*	Alarm Log	16-66 Digital Output
3-4*	Ramp 1		15-30	Alarm Log: Error Code	16-67 Pulse Input #29 [Hz]
3-41	Ramp 1 Ramp Up Time		15-31	InternalFaultReason	16-71 Relay Output [bin]
3-42	Ramp 1 Ramp Down Time		15-4*	Drive Identification	16-72 Counter A
3-5*	Ramp 2		15-40	FC Type	16-73 Counter B
3-51	Ramp 2 Ramp Up Time		15-41	Power Section	16-79 Analog Output AO45
3-52	Ramp 2 Ramp Down Time		15-42	Voltage	16-8* Fieldbus & FC Port
3-8*	Other Ramps		15-43	Software Version	16-86 FC Port REF 1
3-80	Jog Ramp Time		15-44	Ordered TypeCode	16-9* Diagnosis Readouts
3-81	Quick Stop Ramp Time		15-45	Actual Typecode String	16-90 Alarm Word
4-4**	Limits / Warnings		15-46	Drive Ordering No	16-91 Alarm Word 2
4-1*	Motor Limits		15-48	LCP Id No	16-92 Warning Word
4-14	Motor Speed High Limit [Hz]		15-49	SW ID Control Card	16-93 Warning Word 2
4-18	Current Limit		15-50	SW ID Power Card	16-94 Ext. Status Word
			15-51	Drive Serial Number	16-95 Ext. Status Word 2
			15-53	Power Card Serial Number	

**20-\*\*- Drive Closed Loop**

- 20-0\* Feedback
- 20-00 Feedback 1 Source
- 20-01 Feedback 1 Conversion
- 20-03 Feedback 2 Source
- 20-04 Feedback 2 Conversion
- 20-2\* Feedback/Setpoint**
- 20-20 Feedback Function
- 20-8\* PI Basic Settings**
- 20-81 PI Normal/ Inverse Control
- 20-83 PI Start Speed [Hz]
- 20-84 On Reference Bandwidth
- 20-9\* PI Controller**
- 20-91 PI Anti Windup
- 20-93 PI Proportional Gain
- 20-94 PI Integral Time
- 20-97 PI Feed Forward Factor
- 28-\*\*- Compressor Functions**
- 28-0\* Short Cycle Protection**
- 28-00 Short Cycle Protection
- 28-01 Interval between Starts
- 28-02 Minimum Run Time
- 28-1\* Oil Return Management**
- 28-10 Oil Return Management
- 28-11 Low Speed Running Time
- 28-13 Boost Duration
- 28-15 ORM Min Speed Limit [Hz]
- 28-17 ORM Boost Speed [Hz]
- 28-4\* Anti-reverse Protection at Stop**
- 28-40 Reverse Protection Control
- 28-6\* Compressor Readouts**
- 28-60 RPS

## 1.5 Acoustic Noise or Vibration

If the compressor is making noise or vibrations at certain frequencies, try the following:

- Speed Bypass, parameter group 4-6\* *Speed Bypass*

## 1.6 Warnings and Alarms

Fault number	Alarm/Warning Bit Number	Fault text	Warning	Alarm	Trip locked	Cause of problem
2	16	Live zero error	X	X		Signal on terminal 53 or 54 is less than 50% of the value set in 6-10 <i>Terminal 53 Low Voltage</i> , 6-12 <i>Terminal 53 Low Current</i> , 6-20 <i>Terminal 54 Low Voltage</i> or 6-22 <i>Terminal 54 Low Current</i> . See also parameter group 6-0* <i>Analog I/O Mode</i> .
4	14	Mains ph. loss	X	X	X	Missing phase on the supply side or too high voltage imbalance. Check the supply voltage. See 14-12 <i>Function at Mains Imbalance</i> .
7	11	DC overvolt	X	X		Intermediate circuit voltage exceeds the limit.
8	10	DC undervolt	X	X		Intermediate circuit voltage drops below the "voltage warning low" limit.
9	9	Inverter overload	X	X		More than 100% load for too long.
10	8	Motor ETR over	X	X		The motor is too hot due to more than 100% load for too long. See 1-90 <i>Motor Thermal Protection</i>
11	7	Motor th over	X	X		The thermistor or the thermistor connection is disconnected. See 1-90 <i>Motor Thermal Protection</i> .
13	5	Overcurrent	X	X	X	Inverter peak current limit is exceeded.
14	2	Ground Fault		X	X	Discharge from output phases to ground.
16	12	Short circuit		X	X	Short circuit in the compressor or on the compressor terminals.
17	4	Ctrl. word TO	X	X		No communication to the adjustable frequency drive. See parameter group 8-0* <i>General Settings</i> .
18		Start failed		X		The speed has not been able to exceed during start within the allowed time.
30	19	U phase loss		X	X	Motor phase U is missing. Check the phase. See 4-58 <i>Missing Motor Phase Function</i> .
31	20	V phase loss		X	X	Motor phase V is missing. Check the phase. See 4-58 <i>Missing Motor Phase Function</i> .
32	21	W phase loss		X	X	Motor phase W is missing. Check the phase. See 4-58 <i>Missing Motor Phase Function</i> .
38	17	Internal fault		X	X	Contact the local Danfoss supplier.
44	28	Ground Fault		X	X	Discharge from output phases to ground, using the value of 15-31 <i>Alarm Log Value</i> if possible.
47	23	Control Voltage Fault	X	X	X	24 V DC may be overloaded.
48	25	VDD1 supply low		X	X	Control voltage low. Contact the local Danfoss supplier.
49				X		The speed is below the specified limit in .
58		AMA internal	X	X		Contact the local Danfoss supplier.
59	25	Current limit	X			The current is higher than the value in 4-18 <i>Current Limit</i> .

Fault number	Alarm/Warning Bit Number	Fault text	Warning	Alarm	Trip locked	Cause of problem
60	44	External Interlock		X		External interlock has been activated. To resume normal operation, apply 24 V DC to the terminal programmed for external interlock and reset the adjustable frequency drive (via serial communication, digital I/O, or by pressing [Off/Reset]).
69	1	Pwr. Card Temp	X	X	X	The temperature sensor on the power card is either too hot or too cold.
79		Illegal power section configuration	X	X		Internal fault. Contact the local Danfoss supplier.
80	29	Drive initialized		X		All parameter settings are initialized to default settings.
87	47	Auto DC Braking	X			The adjustable frequency drive is auto DC braking
126		Motor Rotating		X		High back emf voltage. Stop the rotor of the PM motor.
250		New spare part		X	X	The power or switch mode power supply has been exchanged. (Only on 400 V 40–125 hp [30–90 kW] units). Contact the local Danfoss supplier.
251		New Typecode		X	X	The adjustable frequency drive has a new type code (only on 400 V 40–125 hp [30–90 kW] units). Contact the local Danfoss supplier.

**Table 1.16 Warnings and Alarms**

## 1.7 General Specifications

### 1.7.1 Line Power Supply 3x200–240 V AC

Adjustable frequency drive	4 TR/VZH028	5 TR/VZH035	6.5 TR/VZH044
Typical shaft output [kW]	6.0	7.5	10
IP20 enclosure protection	H4	H4	H5
Maximum cable size in terminals (line power, compressor) [mm <sup>2</sup> /AWG]	16/6	16/6	16/6
<b>Output current</b>			
Continuous (3x200–240 V) [A]	20.7	25.9	33.7
Intermittent (3x200–240 V) [A]	-	-	37.1
<b>Maximum input current</b>			
Continuous (3x200–240 V) [A]	23.0	28.3	37.0
Intermittent (3x200–240 V) [A]	-	-	41.5
Maximum electrical fuses, see <i>Table 1.9</i>			
Estimated power loss [W], Best case/typical <sup>1)</sup>	182/204	229/268	369/386
Weight enclosure protection IP20 (lbs [kg])	17.4 [7.9]	17.4 [7.9]	21 [9.5]
Efficiency [%], best case/typical <sup>1)</sup>	97.3/97.0	98.5/97.1	97.2/97.1

**Table 1.17 3x200–240 V AC**

<sup>1)</sup> At rated load conditions

## 1.7.2 Line Power Supply 3x380–480 V AC

Adjustable frequency drive	4 TR/VZH028	5 TR/VZH035	6.5 TR/VZH044
Typical shaft output [kW]	6.0	7.5	10
IP20 enclosure protection	H3	H3	H4
Maximum cable size in terminals (line power, compressor) [mm <sup>2</sup> /AWG]	4/10	4/10	16/6
<b>Output current</b>			
Continuous (3x380–440 V) [A]	11.6	14.3	16.4
Intermittent (3x380–440 V) [A]			18.0
Continuous (3x440–480 V) [A]	9.8	12.3	15.5
Intermittent (3x440–480 V) [A]			17.0
<b>Maximum input current</b>			
Continuous (3x380–440 V) [A]	12.7	15.5	18.0
Intermittent (3x380–440 V) [A]			19.8
Continuous (3x440–480 V) [A]	10.8	13.5	17.0
Intermittent (3x440–480 V) [A]			18.7
<b>Maximum electrical fuses</b>			
Estimated power loss [W], best case/typical <sup>1)</sup>	104/131	159/198	248/274
Weight enclosure protection IP20 (lbs [kg])	9.5 [4.3]	9.9 [4.5]	17.4 [7.9]
Efficiency [%], best case/typical <sup>1)</sup>	98.4/98.0	98.2/97.8	98.1/97.9

**Table 1.18 3x380–480 V AC**

1) At rated load conditions

## 1.7.3 EMC Test Results

The following test results have been obtained using a system with an adjustable frequency drive, a shielded control cable, a control box with potentiometer, as well as a compressor shielded cable.

RFI Filter Type	Conduct emission. Maximum shielded cable length (ft [m])						Radiated emission			
	Industrial environment				Housing, trades and light industries		Industrial environment		Housing, trades and light industries	
	EN 55011 Class A2		EN 55011 Class A1		EN 55011 Class B		EN 55011 Class A1		EN 55011 Class B	
	Without external filter	With external filter	Without external filter	With external filter	Without external filter	With external filter	Without external filter	With external filter	Without external filter	With external filter
<b>H4 RFI filter (Class A1)</b>										
CDS 803 IP20			82 [25]	164 [50]		65 [20]	Yes	Yes		No

**Table 1.19 Test Results**

## 1.7.4 General Specifications

### Protection and features

- Electronic thermal compressor protection against overload.
- Temperature monitoring of the heatsink ensures that the adjustable frequency drive trips in case of overtemperature.
- The adjustable frequency drive is protected against short circuits between compressor terminals U, V, W.
- When a compressor phase is missing, the adjustable frequency drive trips and issues an alarm.
- When a line phase is missing, the adjustable frequency drive trips or issues a warning (depending on the load).
- Monitoring of the intermediate circuit voltage ensures that the adjustable frequency drive trips when the intermediate circuit voltage is too low or too high.
- The adjustable frequency drive is protected against ground faults on compressor terminals U, V, W.

### Line power supply (L1, L2, L3)

Supply voltage	200–240 V $\pm 10\%$
Supply voltage	380–480 V $\pm 10\%$
Supply frequency	50/60 Hz
Maximum imbalance temporary between line power phases	3.0% of rated supply voltage
True power factor ( $\lambda$ )	$\geq 0.9$ nominal at rated load
Displacement power factor ( $\cos\phi$ ) near unity	(>0.98)
Switching on the input supply L1, L2, L3 (power-ups)	Maximum 2 times/min.
Environment according to EN 60664-1	Overvoltage category III/pollution degree 2
The unit is suitable for use on a circuit capable of delivering not more than 100000 RMS symmetrical Amperes, 240/480 V maximum.	

### Compressor output (U, V, W)

Output voltage	0–100 % of supply voltage
Output frequency	0–200 Hz (VVC <sup>+</sup> ), 0–400 Hz (u/f)
Switching on output	Unlimited
Ramp times	0.05–3600 s

### Cable lengths and cross-sections

Maximum compressor cable length, shielded/armored (EMC- compatible installation)	See <i>chapter 1.7.3 EMC Test Results</i>
Maximum compressor cable length, unshielded/unarmored	164 ft [50 m]
Maximum cross-section to compressor, line power <sup>1)</sup>	
Cross-section DC terminals for filter feedback on enclosure size H1-H3, I2, I3, I4	4 mm <sup>2</sup> /11 AWG
Cross-section DC terminals for filter feedback on enclosure size H4-H5	16 mm <sup>2</sup> /6 AWG
Maximum cross-section to control terminals, rigid wire	2.5 mm <sup>2</sup> /14 AWG)
Maximum cross-section to control terminals, flexible cable	2.5 mm <sup>2</sup> /14 AWG)
Minimum cross-section to control terminals	0.05 mm <sup>2</sup> /30 AWG

1) See *chapter 1.7.2 Line Power Supply 3x380–480 V AC for more information*

## Digital inputs

Programmable digital inputs	4
Terminal number	18, 19, 27, 29
Logic	PNP or NPN
Voltage level	0–24 V DC
Voltage level, logic 0 PNP	<5 V DC
Voltage level, logic 1 PNP	>10 V DC
Voltage level, logic 0 NPN	>19 V DC
Voltage level, logic 1 NPN	<14 V DC
Maximum voltage on input	28 V DC
Input resistance, $R_i$	Approx. 4 k $\Omega$
Digital input 29 as thermistor input	Fault: >2.9 k $\Omega$ and no fault: <800 $\Omega$
Digital input 29 as Pulse input	Maximum frequency 32 kHz push-pull-driven & 5 kHz (O.C.)

## Analog inputs

Number of analog inputs	2
Terminal number	53, 54
Terminal 53 mode	Parameter 6-19: 1=voltage, 0=current
Terminal 54 mode	Parameter 6-29: 1=voltage, 0=current
Voltage level	0–10 V
Input resistance, $R_i$	Approx. 10 k $\Omega$
Maximum voltage	20 V
Current level	0/4 to 20 mA (scalable)
Input resistance, $R_i$	<500 $\Omega$
Maximum current	29 mA

## Analog output

Number of programmable analog outputs	2
Terminal number	42, 45 <sup>1)</sup>
Current range at analog output	0/4–20 mA
Maximum load to common at analog output	500 $\Omega$
Maximum voltage at analog output	17 V
Accuracy on analog output	Maximum error: 0.4% of full scale
Resolution on analog output	10 bit

1) Terminal 42 and 45 can also be programmed as digital outputs.

## Digital output

Number of digital outputs	2
Terminal number	42, 45 <sup>1)</sup>
Voltage level at digital output	17 V
Maximum output current at digital output	20 mA
Maximum load at digital output	1 k $\Omega$

1) Terminals 42 and 45 can also be programmed as analog output.

## Control card, RS-485 serial communication

Terminal number	68 (P, TX+, RX+), 69 (N, TX-, RX-)
Terminal number	61 common for terminals 68 and 69

## Control card, 24 V DC output

Terminal number	12
Maximum load	80 mA

## Relay output

Programmable relay output		2
Relay 01 and 02	01-03 (NC), 01-02 (NO), 04-06 (NC), 04-05 (NO)	
Maximum terminal load (AC-1) <sup>1)</sup> on 01-02/04-05 (NO) (Resistive load)		250 V AC, 3 A
Maximum terminal load (AC-15) <sup>1)</sup> on 01-02/04-05 (NO) (Inductive load @ cosφ 0.4)		250 V AC, 0.2 A
Maximum terminal load (DC-1) <sup>1)</sup> on 01-02/04-05 (NO) (Resistive load)		30 V DC, 2 A
Maximum terminal load (DC-13) <sup>1)</sup> on 01-02/04-05 (NO) (Inductive load)		24 V DC, 0.1 A
Maximum terminal load (AC-1) <sup>1)</sup> on 01-03/04-06 (NC) (Resistive load)		250 V AC, 3 A
Maximum terminal load (AC-15) <sup>1)</sup> on 01-03/04-06 (NC) (Inductive load @ cosφ 0.4)		250 V AC, 0.2 A
		30 V DC, 2 A
Maximum terminal load (DC-1) <sup>1)</sup> on 01-03/04-06 (NC) (Resistive load)	Minimum terminal load on 01-03 (NC), 01-02 (NO) 24 V DC 10 mA, 24 V AC 20 mA	
Environment according to EN 60664-1		Overvoltage category III/pollution degree 2

1) IEC 60947 parts 4 and 5.

 Control card, 10 V DC output<sup>1)</sup>

Terminal number	50
Output voltage	10.5 V ±0.5 V
Maximum load	25 mA

1) All inputs, outputs, circuits, DC supplies and relay contacts are galvanically isolated from the supply voltage (PELV) and other high-voltage terminals.

## Surroundings

Enclosure	IP20
Enclosure kit available.	IP21, TYPE 1
Vibration test	1.0 g
Maximum relative humidity	5%–95% (IEC 60721-3-3; Class 3K3 (non-condensing) during operation)
Aggressive environment (IEC 60721-3-3), coated (standard)	Class 3C3
Test method according to IEC 60068-2-43 H2S (10 days)	
Ambient temperature	122°F [50°C]

Derating for high ambient temperature, see *chapter 1.8 Special Conditions*.

Minimum ambient temperature during full-scale operation	32°F [0°C]
Minimum ambient temperature at reduced performance	-4°F [-20°C]
Temperature during storage/transport	-22°–149°/158°F [-30°–+65°/70°C]
Maximum altitude above sea level without derating	3,300 ft [1000 m]
Maximum altitude above sea level with derating	10,000 ft [3000 m]
Derating for high altitude, see <i>chapter 1.8 Special Conditions</i>	
Safety standards	EN/IEC 61800-5-1, UL 508C
EMC standards, Emission	EN 61800-3, EN 61000-6-3/4, EN 55011, IEC 61800-3
EMC standards, Immunity	EN 61800-3, EN 61000-3-12, EN 61000-6-1/2, EN 61000-4-2, EN 61000-4-3, EN 61000-4-4, EN 61000-4-5, EN 61000-4-6



## 1.8 Special Conditions

### 1.8.1 Derating for Ambient Temperature and Switching Frequency

The ambient temperature measured over 24 hours should be at least 9 °F [5 °C] lower than the maximum ambient temperature. If the adjustable frequency drive is operated at a high ambient temperature, the continuous output current should be decreased. For derating curves, see *VLT® Compressor Drive CDS 803 Design Guide*.

### 1.8.2 Derating for Low Air Pressure

The cooling capability of air is decreased at low air pressure. For altitudes above 6,600 feet [2 km], contact Danfoss regarding PELV. Below 3,300 ft [1000 m] altitude no derating is necessary, but above 3,300 ft [1000 m] the ambient temperature or the maximum output current should be decreased. Decrease the output by 1% per 330 ft [100 m] altitude above 3,300 ft [1000 m] or reduce the maximum ambient temperature by 2°F [1°C] per 660 ft [200 m].

### 1.9 Options for VLT® Compressor Drive CDS 803

For options, see the *VLT® Compressor Drive CDS 803 Design Guide*.



[www.danfoss.com/drives](http://www.danfoss.com/drives)

.....  
Danfoss shall not be responsible for any errors in catalogs, brochures or other printed material. Danfoss reserves the right to alter its products at any time without notice, provided that alterations to products already on order shall not require material changes in specifications previously agreed upon by Danfoss and the Purchaser. All trademarks in this material are property of the respective companies. Danfoss and the Danfoss logotype are trademarks of Danfoss A/S. All rights reserved.  
.....

Danfoss A/S  
Ulsnaes 1  
DK-6300 Graasten  
[www.danfoss.com/drives](http://www.danfoss.com/drives)

