

MAKING MODERN LIVING POSSIBLE

*Danfoss*



# Operating Instructions

VLT® OneGearDrive



Contents

<b>1 Introduction</b>	<b>4</b>
1.1 Symbols used in this Manual	4
1.2 Approvals	4
1.3 Copyright	4
1.4 Disclaimer	4
1.5 Service and Support	4
1.6 Purpose of these Operating Instructions	4
1.7 Safety Information for the Operation of Geared Motors	5
1.7.1 General	5
1.7.2 Transportation, Storage	5
1.7.2.1 Inspection on Receipt	5
1.7.2.2 Transport	5
1.8 Qualified Personnel	5
1.9 Due Diligence	6
1.10 Intended Use	6
1.11 Foreseeable Misuse	6
<b>2 Installation</b>	<b>7</b>
2.1 Scope of Delivery	7
2.2 Geared Motors Degree of Protection	7
2.3 Protective Coating	7
2.4 Mounting Arrangement	7
2.4.1 Mounting Procedure	7
2.5 Assembly Kit	8
2.6 Torque Restraint	10
2.7 Final Assembly	10
2.8 Electrical Connection	10
2.9 Terminal Box	11
2.9.1 Connection	11
2.10 Cage Clamp Connection Diagram	12
2.11 Three-phase Gear Motors Connection Diagram	13
2.12 Overload Protection	14
<b>3 Commissioning</b>	<b>15</b>
3.1 Measures before Commissioning	15
3.1.1 Overview	15
3.1.2 Motor Component	15
3.1.3 Gear Unit Component	15
3.2 Commissioning	15

<b>4 Service and Maintenance</b>	<b>16</b>
4.1 Maintenance	16
4.1.1 Replacing the Brake and Rotor	16
4.1.2 Adjusting the Nominal Braking Torque and Replacing the Springs	17
4.2 Inspection during Operation	17
4.3 Repair	18
4.4 Lubricants	18
4.4.1 Lubricant Changes	18
4.4.2 Lubricant Grade	18
4.4.3 Lubricant Volume	19
4.4.4 Changing the Oil	20
4.5 Spare Parts	20
<b>5 Decommissioning and Disposal</b>	<b>21</b>
5.1 Decommissioning	21
5.2 Dismounting	21
5.3 Product Returns	21
5.4 Disposal	21
<b>6 Specifications</b>	<b>22</b>
6.1 Nameplate	22
6.2 Storage	22
6.3 Permanent Magnet Three-phase Synchronous Motor	22
6.4 General Specifications and Environmental Conditions	22
6.5 Electromagnetic Compatibility	23
6.6 Dimensions	23
6.6.1 VLT® OneGearDrive Standard	23
6.6.2 VLT® OneGearDrive Standard with Torque Arm in Front Position (optional)	24
6.6.3 VLT® OneGearDrive Hygienic	25
6.6.4 VLT® OneGearDrive Hygienic with Torque Arm in Front Position (optional)	26
6.7 Options	27
6.7.1 Torque Arm Set	27
6.7.2 Mechanical Brake	29
6.7.2.1 Overview	29
6.7.2.2 Technical Data	29
6.7.2.3 Dimensions	29
6.7.2.4 Connections	30
6.8 Accessories	31
6.8.1 Accessories for VLT® OneGearDrive Standard	31
6.8.2 Accessories for VLT® OneGearDrive Hygienic	31

<b>Index</b> .....	32
--------------------	----

## 1 Introduction

### 1.1 Symbols used in this Manual

The following symbols are used in this manual.



Indicates a potentially hazardous situation which, if not avoided, could result in death or serious injury.



Indicates a potentially hazardous situation which, if not avoided, may result in minor or moderate injury. It may also be used to alert against unsafe practices.

### CAUTION

Indicates a situation that may result in equipment or property-damage-only accidents.

### NOTE

Indicates highlighted information that should be regarded with attention to avoid mistakes or operating equipment at less than optimal performance.

### 1.2 Approvals



Table 1.1 Approvals

### 1.3 Copyright

Disclosure, duplication and sale of this document, as well as communication of its content, are prohibited unless explicitly permitted. Infringement of this prohibition incurs liability for damages. All rights reserved with regard to patents, utility patents, and registered designs. OneGearDrive is a registered trademark.

### 1.4 Disclaimer

No liability is assumed for any damage or breakdown resulting from:

- Failure to observe the information in the instruction manuals
- Unauthorised modifications to the VLT® OneGearDrive
- Operator error
- Improper work on or with the VLT® OneGearDrive.

### 1.5 Service and Support

Contact your local service representative for service and support:

[www.danfoss.com/Contact/Worldwide/](http://www.danfoss.com/Contact/Worldwide/)

### 1.6 Purpose of these Operating Instructions

The purpose of these Operating Instructions is to describe the VLT® OneGearDrive. These Operating Instructions contain information about:

- Safety
- Installation
- Commissioning
- Maintenance and Repair
- Specifications
- Options and Accessories

### NOTE

For reasons of clarity, the Operating Instructions and safety information do not contain all information relating to all geared motors types and cannot take into account every conceivable case of installation, operation, or maintenance. The information is limited to that which is required for qualified personnel in normal working situations. Any unclear points can be clarified by contacting Danfoss.

These Operating Instructions are intended for use by qualified personnel. Read these Operating Instructions in full in order to use the VLT® OneGearDrive safely and professionally. Pay particular attention to the safety instructions and general warnings.

These Operating Instructions are an integral part of the VLT® OneGearDrive and also contain important service information. Therefore keep these operating instructions available with the VLT® OneGearDrive at all times.

Compliance with the information in the Operating Instructions is a prerequisite for:

- Trouble-free operation
- Recognition of product liability claims

Therefore, read these Operating Instructions before working with the VLT® OneGearDrive.

## 1.7 Safety Information for the Operation of Geared Motors

### 1.7.1 General

This safety information applies in addition to the relevant product-specific Operating Instructions and for safety reasons must be taken into particular consideration in every case. This safety information is intended to protect persons and objects from injury and hazards which can arise from improper use, incorrect operation, inadequate maintenance, or other incorrect handling of electric drive units in industrial installations. Low-voltage machines have rotating parts and may have parts that are live, even when the machine is at rest, and surfaces that may become hot in operation. Warning signs and information signs on the machine must be observed without exception. Details can be found in our detailed Operating Instructions. They are provided with the machine when it is supplied and can be requested separately as required by stating the motor model.

### 1.7.2 Transportation, Storage

#### 1.7.2.1 Inspection on Receipt

After receiving the delivery, immediately check whether the scope of delivery matches the shipping documents. Danfoss will not honour claims for faults registered later.

Register a complaint immediately:

- with the carrier in case of visible transport damage
- with the responsible Danfoss representative in case of visible defects or incomplete delivery

Commissioning may have to be suspended if the unit is damaged.

#### 1.7.2.2 Transport

Before transporting the VLT® OneGearDrive the eye bolt provided must be firmly tightened down to its bearing surface. The eye bolt can only be used to transport the VLT® OneGearDrive unit and not for lifting attached machines.

If the VLT® OneGearDrive is to be stored, ensure a dry, dust free environment with a low vibration rating of  $v_{\text{eff}} < 0,2 \text{ mm/s}$ .

Damage sustained during storage:

- The life of the lubricants and seals is reduced with longer storage times.
- There is a risk of fracture at very low temperatures (under approximately  $-20 \text{ }^{\circ}\text{C}$ )
- If the transport eye bolts are replaced, use drop forged eye bolts as specified in DIN 580.

## 1.8 Qualified Personnel

All necessary work on electric drive units, in particular also planning work, transport, assembly, installation, commissioning, maintenance, repair, may only be performed by adequately qualified personnel (e.g. electrical engineers as specified in draft EN 50 110-1/DIN VDE 0105), who have the Operating Instructions provided and other product documentation available during any corresponding work and who are obliged to abide by the instructions contained therein. This work must be monitored by a specialist supervisor. Qualified personnel are persons who are authorised due to training, experience, and instruction as well as their knowledge of relevant standards, rules, accident prevention regulations, and operating conditions. The person responsible for the safety of the installation must perform the activities required in each case and be able to recognise and avoid potential hazards. Knowledge of first-aid measures and of the available lifesaving equipment is also required.

Non-qualified personnel are forbidden to work on the VLT® OneGearDrive.

## 1.9 Due Diligence

The operator and/or fabricator must ensure that:

- The units are used only as intended
- The units are operated only in a perfect operational condition. The Operating Instructions are always available near the unit in complete and readable form
- The unit is fitted, installed, commissioned, and maintained only by adequately qualified and authorised personnel
- These personnel are regularly instructed on all relevant matters of occupational safety and environmental protection, as well as the contents of the Operating Instructions and in particular the instructions it contains
- The product markings and identification markings applied to the unit, as well as safety and warning instructions, are not removed and are always kept in a legible condition
- The national and international regulations regarding the control of machinery and equipment, that are applicable at the place of use, are complied with
- The users always have all current information relevant to their interests about the unit and its use and operation

## 1.10 Intended Use

These machines are intended for commercial installations, unless otherwise expressly agreed. They comply with the standards of the series EN 60034/DIN VDE 0530. Use in a potentially explosive atmosphere is forbidden, if not expressly intended for this purpose. If in a special case - use in non-commercial installations - increased safety precautions are required (e.g. protection against access by children's fingers), these conditions must be ensured when setting up the installation. The machines are designed for ambient temperatures between -20 °C to +40 °C as well as for installation heights up to 1000 m above sea level. Any deviations found on the nameplate must be considered. Ensure that the conditions at the place of work correspond to all the nameplate data.

## CAUTION

Low-voltage machines are components for installation in machines in the sense of the machinery directive 2006/42/EC. It is forbidden to use the machine until conformity of the final product with this directive is established (refer to EN 60204-01).

## 1.11 Forseeable Misuse

Any use not expressly approved by Danfoss constitutes misuse. This also applies to failure to comply with the specified operating conditions and applications.

Danfoss assumes no liability of any sort for damage attributable to improper use.



## 2 Installation

### 2.1 Scope of Delivery

The scope of delivery of the VLT® OneGearDrive comprises:

- VLT® OneGearDrive
- These operating instructions
- Eyebolt
- Plastic cap for eyebolt opening
- Hollow shaft cover with 3 fixing screws
- Disc, lock washer and retaining ring

### 2.2 Geared Motors Degree of Protection

The VLT® OneGearDrive range complies with EN 60529 and IEC 34-5/529. The drives are totally enclosed and dust-tight as well as hose proof.

The VLT® OneGearDrive-Basic is supplied as standard in IP67.

The VLT® OneGearDrive-Standard is for use in aggressive areas and is supplied in IP67. The VLT® OneGearDrive-Hygienic is available in both IP67 and IP69K.

### 2.3 Protective Coating

#### CAUTION

**Damage to the protective coating**

**Damage to the paint coating reduces its protective function.**

- **Handle the VLT® OneGearDrive with care and do not place it on any rough surfaces.**

### 2.4 Mounting Arrangement

#### CAUTION

**Depending on the reduction ratio, geared motors develop substantially higher torques and forces than high-speed motors of similar power.**

**Mounts, substructure and torque restraint must be rated for the high forces anticipated during operation and secured sufficiently against loosening. Cover the output shaft(s) and any second motor shaft extension present, as well as the transmission elements mounted on it (couplings, chain wheels etc.), so that they cannot be touched.**

Install the drive unit as free from vibration as possible.

Observe the special instructions for installation locations with abnormal operating conditions (e.g. high ambient temperatures above 40 °C). The fresh air intake must not be restricted by unsuitable installation or by fouling.

Commercially available slip clutches are recommended if there is a risk of blocking.

Take care when fitting transmission elements onto the hollow shaft of the gear unit, which is finished to ISO H 7. Use the tapped end hole intended for this purpose according to DIN 332 if possible.

#### 2.4.1 Mounting Procedure

1. Fasten the drive unit by its flange.
2. Attach the gear units with hollow shafts on to the driven shaft using the means provided.

2

2.5 Assembly Kit

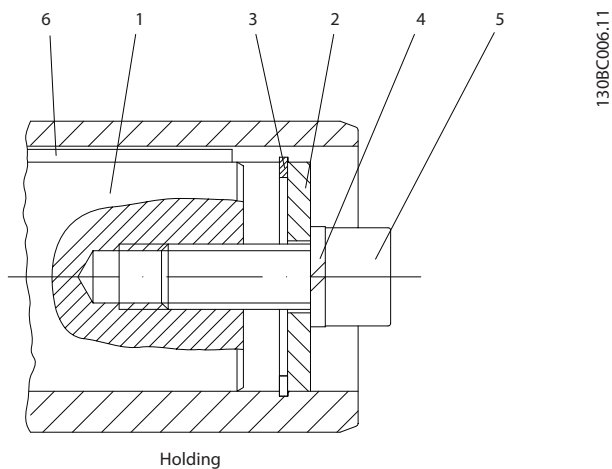

Illustration 2.1 Assembly Kit

1	Shaft
2	Disc
3	Retaining ring
4	Lock washer
5	Fixing screw (filister head)
6	Key

Table 2.1 Legend to Illustration 2.1

Type	Dimensions [mm]			
	Retaining ring (3) DIN 472	Lock washer (4) DIN 7980	Fixing screw (5) DIN 912-8.8	Key (6) DIN 6885 Width x Height x Length
OGD-30	30x1.2	10	M10x30	A 8x7x100 <sup>1)</sup>
OGD-35	35x1.5	12	M12x35	A 10x8x100 <sup>1)</sup>
OGD-40	40x1.75	16	M16x35	A 12x8x100 <sup>1)</sup>

Table 2.2 Dimensions

1) Key length required for  $b_{min}$  in Table 2.3. Adapt the key length according to the shaft length used (b) in Table 2.3.

The dimensions shown could differ from the customer conditions and must potentially be changed by the customer.

**Mounting Instructions**

Rotate the disc (2) and fit it against the retaining ring (3). Both items are included in every delivery.

The fixing screw (5) and lock washer (4) are not included in the delivery. The parts are dependant on the length and size of the shaft. For further information refer to the mounting arrangement, see 2.4 Mounting Arrangement.

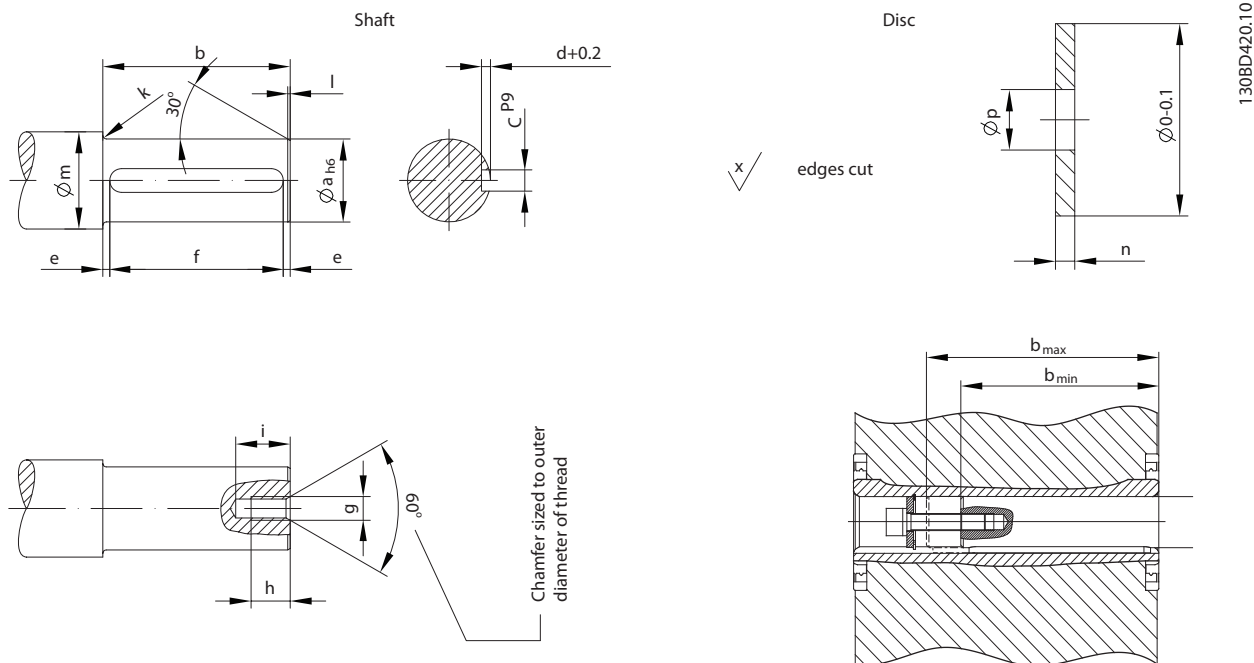

Illustration 2.2 Axial Fastening

Type	Dimensions [mm]															
	Shaft													Disc		
	a	b <sub>min</sub>	b <sub>max</sub>	c	d	e	f	g	h	i	k	l	m	n	o	p
OGD-30	30	120	140	8	4	5	100 <sup>1)</sup>	M10	22	30	3	1.5	38	4	29.8	11
OGD-35	35	120	140	10	5	5	100 <sup>1)</sup>	M12	28	37	3	1.5	43	4	34.8	13
OGD-40	40	120	140	12	5	5	100 <sup>1)</sup>	M16	36	45	3	2	48	4	39.8	17

Table 2.3 Dimensions

1) Key length required for b<sub>min</sub>. Adapt the key length according to the shaft length used (b).

The dimensions shown could differ from the customer conditions and must potentially be changed by the customer.

**NOTE**

Use grease to mount the VLT® OneGearDrive onto the shaft. For example, CASTROL Obeen Paste NH1, ARAL Noco Fluid or similar.

Use a key in the same material and quality as the hollow shaft.

2

## 2.6 Torque Restraint

Shaft-mounted geared motors require a suitable torque restraint to resist the reaction torque. Torque arm with mounting sets are available as an option (see 6.7.1 *Torque Arm Set*). It is always important to ensure that the torque arm does not create excessive constraining forces due to the driven shaft running untrue, for example. Excessive backlash can result in excessive shock torques in switching or reversing operations.

## 2.7 Final Assembly

Always assemble the hollow shaft cover with the delivered screw as shown in *Illustration 2.3*.

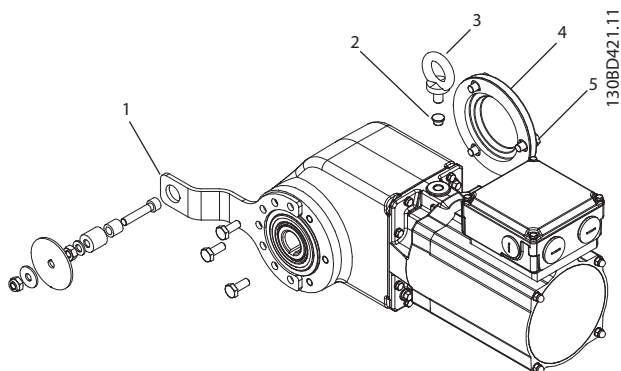

Illustration 2.3 Final Assembly

1	Torque arm (optional)
2	Plastic cap
3	Eyebolt
4	Shaft cover
5	Shaft cover screws

Table 2.4 Legend to *Illustration 2.3*

1. Remove the eyebolt and cover the hole with the plastic cap (supplied). This ensures the hygienic features of a smooth surface.
2. Assemble the hollow shaft cover with the 3 screws (delivered) onto the VLT® OneGearDrive. The tightening torque is 4.5 Nm.

## 2.8 Electrical Connection

When connecting the motor, take note of the data on the nameplate, the connection diagram, and the relevant safety regulations and rules for the prevention of accidents.

Unless a special design is concerned, the data on the nameplate refers to  $\pm 5\%$  voltage tolerance, to  $-20$  to  $40^\circ\text{C}$  ambient temperature and altitudes up to 1000 m above sea level.

When closing the terminal box, pay particular attention to obtaining a perfect seal.

To guarantee electromagnetic compatibility (EMC) as defined in EMC Directive 2004/108/EC, all signal lines must use shielded cables. The cable sheath must be earthed at both ends. The frequency inverter operating instructions indicate whether a shielded cable is necessary for the motor supply line. A shielded motor cable is not required when connecting to the low-voltage network or to a frequency inverter with an output filter. Always use shielded cables when laying Signal cables and power cables parallel to each other.

## 2.9 Terminal Box

The cables of motors with and without brakes can be fed into the motor terminal box and then connected.

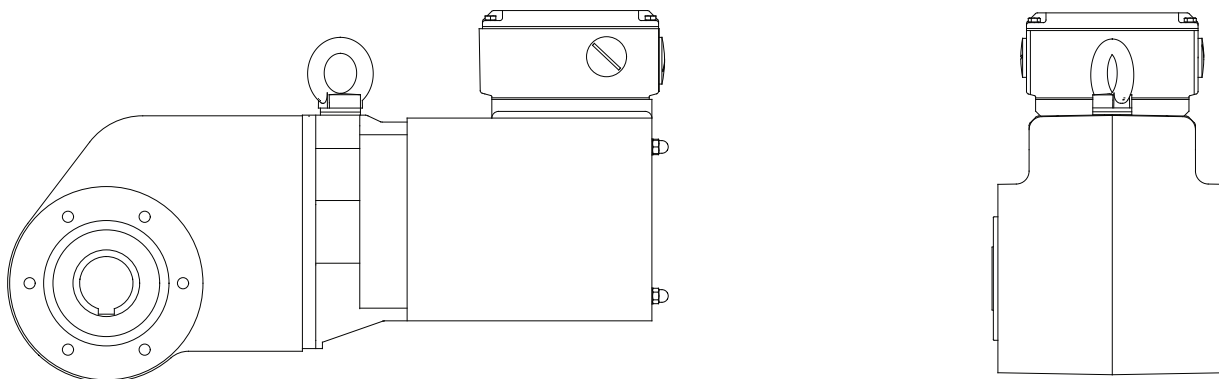

130BB498.12

Illustration 2.4 Terminal Box

The standard position for the motor terminal box is shown in the dimensional drawings for the geared motor (see 6.6.1 VLT® OneGearDrive Standard).

Screw-on terminal boxes are supplied with a metric screw thread as standard.

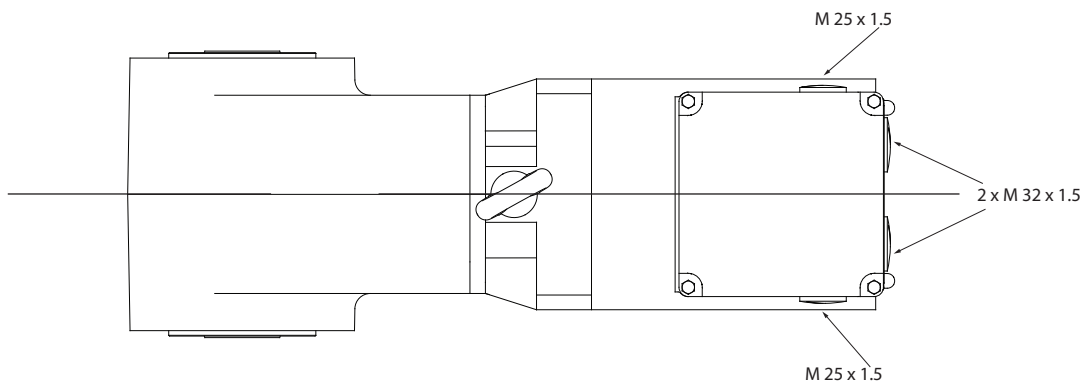

130BC003.11

Illustration 2.5 Terminal Box Screws

### 2.9.1 Connection

The terminal box may only be opened once it has been ensured that the power is switched off. The information on voltage and frequency on the nameplate must correspond with the mains voltage under observance of the terminal circuit. Exceeding the tolerances as in EN 60034 / DIN VDE 0530, i.e. voltages  $\pm 5\%$ , frequency  $\pm 2\%$ , cam form, symmetry, increases heating and reduces service life. Observe any accompanying connection diagrams, particularly for special equipment (e.g. thermistor protection etc.). The type and cross-section of the main conductors, as well as the protective conductors and any potential equalization which may become necessary, must correspond to

the general and local installation regulations. With switching duty, take the starting current into account. Protect the drive unit against overload and in dangerous situations against automatic restarting due to inadvertent starting.

Lock the terminal box again to protect against contact with live components.

2.10 Cage Clamp Connection Diagram

2

**CAUTION**

Refer to the Operating Instructions for VLT® AutomationDrive FC 302 and VLT® Decentral Drive FCD 302 to connect the terminals.

Do not connect the VLT® OneGearDrive directly to the power supply.

Illustration 2.6 shows the VLT® OneGearDrive DA09LA10 with terminal box in Y-connection and the connection to the thermal protection.

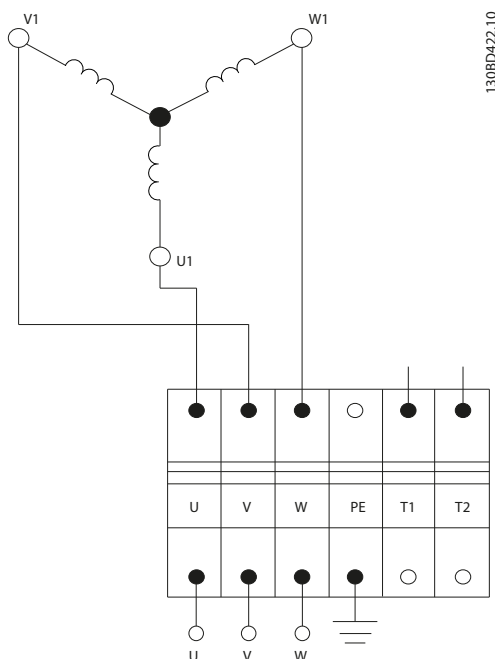

1308DA22.10

Illustration 2.6 Cage Clamp Connection Diagram

Description	Inverter output	Colour	Typical cross section	Maximum cross section
Motor winding	U	black	AWG 16/1.5 mm <sup>2</sup>	AWG 14/2.5 mm <sup>2</sup>
	V	blue		
	W	brown		
Protective Earth	PE	yellow/green	AWG 16/1.5 mm <sup>2</sup>	AWG 14/2.5 mm <sup>2</sup>
Temperature protection <sup>1)</sup> KTY 84-130	T1	white	AWG 20/0.75 mm <sup>2</sup>	AWG 16/1.5 mm <sup>2</sup>
	T2	brown		

Table 2.5 Cage Clamp Connections

1) When connected to VLT® AutomationDrive FC 302 and VLT® Decentral Drive FCD 302, use analog input terminal 54, KTY sensor 1. For information about parameter setting and programming, refer to the corresponding operating instructions.

T1	KTY 84-130	VLT® AutomationDrive FC 302 <sup>1)</sup>	VLT® Decentral Drive FCD 302 <sup>1)</sup>
T2		KTY Sensor 1 Analog Input 54	

Table 2.6 Connections T1 and T2

1) Only if connected

2.11 Three-phase Gear Motors Connection Diagram

**CAUTION**

Refer to the Operating Instructions for VLT® AutomationDrive FC 302 and VLT® Decentral Drive FCD 302 to connect the terminals.

Do not connect the VLT® OneGearDrive directly to the power supply.

Illustration 2.7 shows the connection power plug for VLT® OneGearDrive Hygienic DA09LA10 in Y-connection with thermistors.

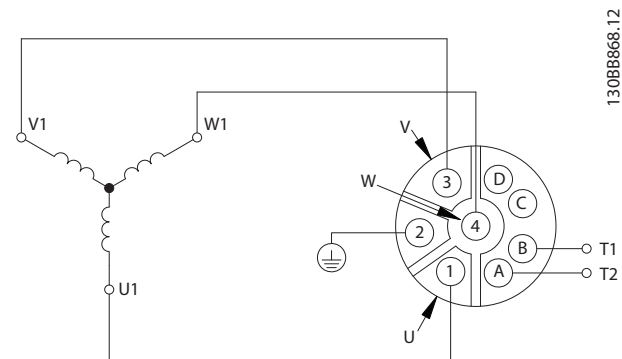

Illustration 2.7 Three-phase Gear Motor Connections

Description	Inverter output	Pin	Typical cross section	Maximum cross section
Motor winding	U	1	AWG 16/1.5 mm <sup>2</sup>	AWG 14/2.5 mm <sup>2</sup>
	V	3		
	W	4		
Protective Earth	PE	2	AWG 16/1.5 mm <sup>2</sup>	AWG 14/2.5 mm <sup>2</sup>
Temperature protection <sup>1)</sup> KTY 84-130	T1	A	AWG 20/0.75 mm <sup>2</sup>	AWG 16/1.5 mm <sup>2</sup>
	T2	B		

Table 2.7 Three-phase Gear Motor Connections

1) When connected to VLT® AutomationDrive FC 302 and VLT® Decentral Drive FCD 302, use analog input terminal 54, KTY sensor 1. For information about parameter setting and programming, refer to the corresponding operating instructions.

T1		VLT® AutomationDrive FC 302 <sup>1)</sup>	VLT® Decentral Drive FCD 302 <sup>1)</sup>
T2	KTY 84-130	KTY Sensor 1 Analog Input 54	

Table 2.8 Connections T1 and T2

1) Only if connected

## 2

## 2.12 Overload Protection

Take note of the relevant circuit diagram for motors with thermally activated winding protection (see 2.10 *Cage Clamp Connection Diagram*).

Automatic restarting after the winding has cooled must be avoided in most applications.

The output of the motors is normally adequately rated. The rated current does not represent a measure of gear unit utilization in these cases and cannot be used as overload protection for the gear unit. In some cases, the way in which the driven machine is loaded can exclude any overloading as a matter of course. In other cases it is prudent to protect the gear unit by mechanical means (e.g. slip clutch, sliding hub etc.). This depends on the maximum permissible limit torque  $M_2$  in continuous running duty specified on the nameplate.



## 3 Commissioning

### 3.1 Measures before Commissioning

#### 3.1.1 Overview

If the VLT® OneGearDrive has been stored, the measures detailed in 3.1.2 *Motor Component* and 3.1.3 *Gear Unit Component* must be taken.

#### 3.1.2 Motor Component

- **Insulation measurement**  
Measure the insulation resistance of the winding with commercially available measuring apparatus (e.g. with a megger) between all winding parts and between the winding and the enclosure.

Measured value	Action/State
> 50 megohm	No drying necessary, new condition
< 5 megohm	Drying advised
approx 50 megohm	Lowest permissible threshold

Table 3.1 Insulation Measurement Values

#### 3.1.3 Gear Unit Component

- **Lubricant**  
The lubricant in the gear unit must be changed if the storage period exceeds 3 years or the temperatures were very harsh throughout a shorter storage period. For detailed instructions and lubricant recommendations see 4.4.3 *Lubricant Volume*.
- **Shaft seals**  
Lubricate the hollow shaft seal with grease if the storage period exceeds 2 years. When changing the lubricant, the function of the shaft seals between the motor and gear unit as well as on the output shaft must also be checked. The shaft seals must be replaced if any change in shape, colour, hardness or sealing effect is detected.

### 3.2 Commissioning

- Remove the protective films.
- Disconnect the mechanical connection to the driven machine as far as possible and examine the direction of rotation in the no-load state.
- Remove feather keys or secure them in such a way that they cannot be ejected.
- Ensure that the current draw in the loaded condition does not exceed the rated current indicated on the nameplate for any length of time.
- Observe the drive unit after first commissioning for at least one hour for any unusual heat or noise.

## 4 Service and Maintenance

### **⚠ WARNING**

#### HIGH VOLTAGE

Potentially lethal voltage is present on the connectors. Before working on the power connectors (disconnecting or connecting the cable), disconnect the power supply module from the mains and wait for the discharge time to elapse.

### **⚠ WARNING**

#### DISCHARGE TIME

The DC link capacitors remain charged for some time after the mains supply is switched off.

To avoid electrical shock, fully disconnect the VLT® OneGearDrive from the mains before carrying out maintenance. Wait for at least 10 minutes before carrying out maintenance work.

### 4.1 Maintenance

To prevent breakdown, danger, and damage, examine the drive units at regular intervals depending on the operating conditions. Replace worn or damaged parts using original spare parts or standard parts.

The VLT® OneGearDrives are largely maintenance free.

The maintenance tasks listed in *Table 4.1* may be performed by the customer. No other tasks are required.

Component	Maintenance task	Maintenance interval	Instruction
VLT® OneGearDrive	Check for abnormal noise and vibration	Every 6 months	Contact Danfoss Service
Protective coating	Check for damage	Every 6 months	Repair damage using the Danfoss Paint Repair Set
Hollow shaft seal (stainless steel shaft)	Check the condition and check for leakage	Every 6 months	If damaged replace with a Viton seal
Hollow shaft seal (mild steel shaft)	Check the condition and check for leakage	Every 6 months	If damaged replace with an EPDM seal
Oil	Change the oil	Standard oil: after 25000 operating hours Food grade oil: after 35000 operating hours	See <i>4.4.4 Changing the Oil</i>
	Check for oil leakage on gear and motor housing	Every 12 months	Replace the VLT® OneGearDrive

**Table 4.1 Overview of Maintenance Tasks**

#### 4.1.1 Replacing the Brake and Rotor

All work can only be carried out by qualified technical personnel on a stationary machine, which has been protected against restarting. This also applies to auxiliary circuits.

4.1.1.1 Illustration

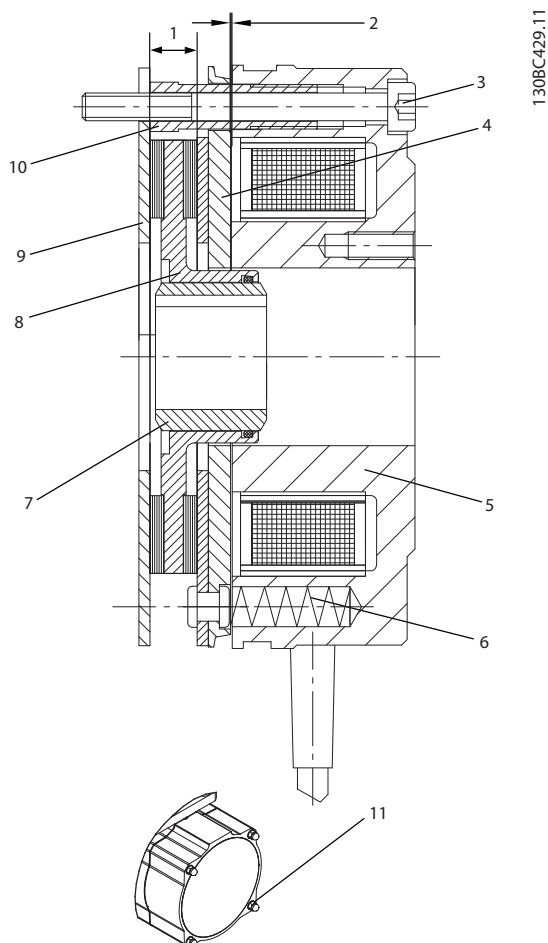

Illustration 4.1 Brake and Rotor

1	Rotor width, minimum 5.5 mm
2	Air gap, maximum 0.45 mm
3	Fastening screws
4	Armature plate
5	Magnet
6	Springs
7	Hub for rotor
8	Rotor
9	Friction Plate
10	Hollow screws
11	Brake Cover and nuts

Table 4.2 Legend to Illustration 4.1

1. Open the brake completely by turning the brake cover nuts (11) counter-clockwise.
2. Loosen the fastening screws (3) completely by turning them counter-clockwise.
3. Remove the installed brake and rotor from the hub of the rotor (7).

4. Assemble the new brake and rotor on the hub of the rotor (7).
5. Tighten the fastening screws (3).
6. Close the brake cover and tighten the covering nuts.

**CAUTION**

Even after the exchange of the rotor, the complete braking torque will only be effective after the brake linings at the rotor have been run in.

Check the brake cover seal before closing it and exchange the seal if any damage is detected.

4.1.2 Adjusting the Nominal Braking Torque and Replacing the Springs

The nominal braking torque can be adjusted and broken springs can be replaced. Follow the instructions in 4.1.1 Replacing the Brake and Rotor to open the brake as reference for the nominal braking torque:

Nominal braking torque in Nm	Number of springs
10	7
7	5
6	4
4	3

Table 4.3 Nominal Braking Torque

4.2 Inspection during Operation

Changes in relation to normal operation, such as higher temperatures, vibrations, noises etc. tend to indicate that the function is impaired. To avoid faults which could lead directly or indirectly to injury to persons or damage to property, inform the maintenance staff responsible. If in any doubt, switch the geared motors off immediately.

Carry out regular inspections during operation. Check the VLT® OneGearDrive at regular intervals for anything unusual.

Pay particular attention to:

- Unusual noises
- Overheated surfaces (temperatures up to 70 °C may occur in normal operation)
- Uneven running
- Strong vibrations
- Loose fastenings
- Condition of electrical wiring and cables
- Poor heat dispersion

In the event of irregularities or problems, contact Danfoss Service.

### 4.3 Repair

#### NOTE

Always return defective VLT® OneGearDrives to the local Danfoss Sales Company.

### 4.4 Lubricants

#### 4.4.1 Lubricant Changes

The gear units are supplied with lubricant ready for operation.

Table 4.4 shows the oil change intervals based on normal operating conditions and a lubricant temperature of approximately 80 °C. The lubrication interval must be reduced at higher temperatures (halve it for each 10 K increase in the lubricant temperature).

Lubricant type	Lubricant change interval
PGLP220	25000 operating hours
Optileb GT220 H1 (food grade)	35000 operating hours

Table 4.4 Lubricant Change Intervals

#### 4.4.2 Lubricant Grade

Oils PGLP 220 and PGLP 68 comply with DIN 51502 and DIN 51517 and are suitable for lubricating the gear unit. Food grade oils which comply with NSF H1 can be used.

The lubricant must permit low-friction, virtually wear-free continuous operation. The damage load level on the FZG test as specified in DIN 51354 should be in excess of load level 12, and the specific wear below 0.27 mg/kWh. The lubricant should not foam, should protect against corrosion, and should not attack the interior paint, the rolling contact bearings, gearwheels, and seals.

Lubricants of different types may not be mixed, as this may impair the lubrication characteristics. A long service life is only ensured by the use of a lubricant listed in Table 4.5 or equivalent.

If the VLT® OneGearDrive is stored for a longer period of time before installation, refer to 6.2 Storage.

The following wear-protecting EP gear lubricant oils are recommended.

Lubricant Manufacturer	Standard oil Synthetic oil PGLP 220	Low temperature Synthetic oil PGLP 68	Food Grade Oil NSF USDA H1 oil
ARAL	Degol GS 220	–	Eural Gear 220
BP	Enersyn SP-XP 220	–	–
CASTROL	Alphasyn PG 220 OPTIFLEX A 220	–	OPTILEB GT 220
FUCHS	Renolin PG 220	Renolin PG 68	–
KLÜBER	Klübersynth GH 6-220	Klübersynth GH 6-80	Klüberoil 4UH1-220N
MOBIL	Glygoyle HE 220 Glygoyle 30	–	–

The gear units have filling plugs and drain plugs. In the standard designs, these make it possible to change the lubricant without disassembly.

It is also necessary to flush the gear unit enclosure if the lubricant grade or lubricant type is changed. If the motor is only used briefly, it is sufficient to drain off the original oil and use the original lubricant type to refill the maximum possible amount for the gear unit as defined on the nameplate. Then operate the drive unit briefly under no load, drain this oil off again and refill with the new lubricant as defined on the nameplate.

If necessary, drain off the original lubricant and flush out the gear unit with petroleum until all traces have been washed out. Then perform the procedure described for short-term operation twice before filling with the specified volume of new lubricant in accordance with the nameplate.

Inspect, and if necessary replace, the wear parts (seals) when changing the lubricant.

Lubricant Manufacturer	Standard oil Synthetic oil PGLP 220	Low temperature Synthetic oil PGLP 68	Food Grade Oil NSF USDA H1 oil
OEST	–	–	Cassida Fluid GL 220
SHELL	Omala S4 GX 220	–	–
TEXACO	–	–	NEVASTANE SL220

Table 4.5 Lubricant Grades

## NOTE

Synthetic gear oils with a polyglycol base (e.g. PGLP etc.) must be kept separate from mineral oils and disposed of as special waste.

As long as the ambient temperature does not fall below -10 °C, ISO viscosity grade VG 220 (SAE 90) is recommended. This is as specified in the international definition of viscosity grades at 40 °C in accordance with ISO 3448 and DIN 51519 and for North America, AGMA 5 EP.

For lower ambient temperatures, oils of a lower nominal viscosity, with correspondingly better starting characteristics, should be used. For example, PGLP with a nominal viscosity of VG 68 (SAE 80) or AGMA 2 EP. These grades may also be required at temperatures around the freezing point in the following circumstances:

- If the drive unit's break-away torque has been reduced with a view to achieving soft starting
- If the motor has a relatively low-power output

### 4.4.3 Lubricant Volume

The recommended lubricant quantity for the particular mounting position is indicated on the motor nameplate. When filling, ensure that the upper gear unit components are also well lubricated.

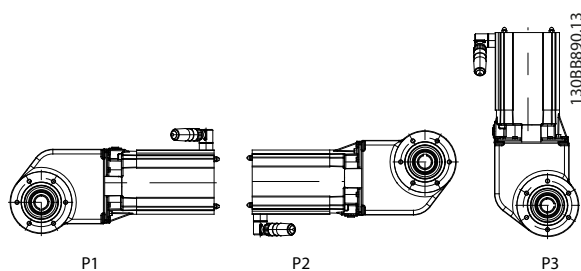

Illustration 4.2 Mounting Positions

	Mounting Position		
	P1 <sup>1)</sup>	P2	P3
Lubricant Volume for VLT® OneGearDrive	2.2 l		2.9 l

Table 4.6 Lubricant Volume in Litres

1) P1 is no longer available in the Danfoss DRIVECAT configurator. Use P2 also for P1 installations.

#### 4.4.4 Changing the Oil

### CAUTION

Danger of burns

The surface of the VLT® OneGearDrive can reach high temperatures during operation.

- Do not touch the VLT® OneGearDrive until it has cooled down.

### CAUTION

Danger of burns

The oil in the VLT® OneGearDrive reaches high temperatures during operation.

- Do not carry out the oil change until the oil has cooled down sufficiently.

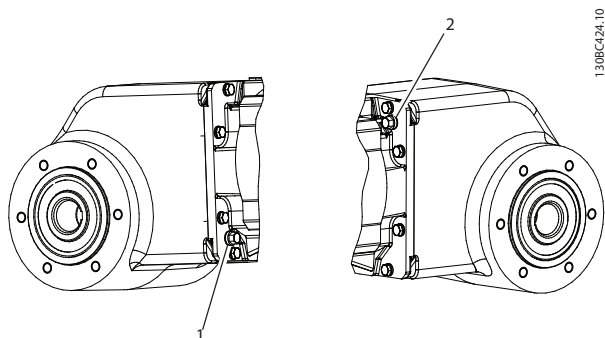

Illustration 4.3 VLT® OneGearDrive Oil Screws 1 and 2

Filling the oil

### NOTE

The required oil quantities can be found on the nameplate and in 4.4.3 *Lubricant Volume*.

- Fill the VLT® OneGearDrive with the appropriate amount of oil through screw hole 1.
- Remove all traces of oil from the surface of the VLT® OneGearDrive using a soft cloth.
- Re-insert and tighten oil screws 1 and 2.

#### 4.5 Spare Parts

Spare parts can be ordered via the Danfoss VLT Shop: [vltshop.danfoss.com](http://vltshop.danfoss.com)

#### Draining the oil

- Once the VLT® OneGearDrive has cooled down, remove it from your system
- Bring the VLT® OneGearDrive into a vertical position and remove oil screws 1 and 2
- Turn the VLT® OneGearDrive into a horizontal position and drain the oil through screw hole 1 into a suitable container
- Turn the VLT® OneGearDrive back into a vertical position

## 5 Decommissioning and Disposal

### 5.1 Decommissioning

#### **⚠ WARNING**

##### **HIGH VOLTAGE**

Potentially lethal voltage is present on the connectors. Before working on the power connectors (disconnecting or connecting the cable), disconnect the power supply module from the mains and wait for the discharge time to elapse.

#### **⚠ WARNING**

##### **DISCHARGE TIME**

Permanent magnet motors can act as generators. Do not allow rotational torque onto the motor shaft if connection terminals are exposed.

Proceed as follows:

1. Disconnect power supply and wait for the discharge time to elapse.
2. Disconnect the electrical cables.

### 5.2 Dismounting

Proceed as follows:

1. Disconnect power supply and wait for the discharge time to elapse.
2. Disconnect the electrical cables.
3. Dismount the VLT® OneGearDrive.

### 5.3 Product Returns

Products we manufactured can be returned to us for disposal at no charge. A prerequisite for this is that they are free of deposits, such as oil, grease or other types of contamination, that hamper disposal.

Furthermore, no unsuitable foreign materials or third-party components may be included with the returned product.

Ship the products FOB to the local Danfoss Sales Company.

### 5.4 Disposal

The metallic parts of the gear unit and the geared motor can be disposed of as scrap, segregated into steel, iron, aluminium and copper.

The lubricants should be disposed of as waste oil, and the synthetic oils should be disposed of as special waste.

## 6 Specifications

### 6.1 Nameplate

Danfoss geared motors are supplied with a corrosion-proof nameplate as standard. The standard nameplate is made of special plastic tried and tested in many years of practical use and approved for hazardous areas by the Physikalisch-Technische-Bundesanstalt (PTB).

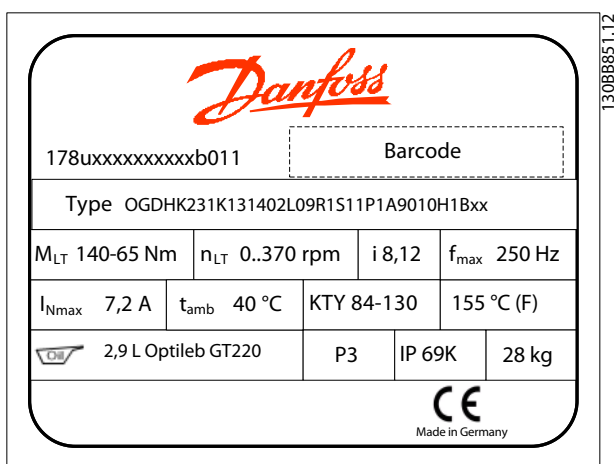

Illustration 6.1 Example Nameplate

### 6.2 Storage

If the VLT® OneGearDrive is being stored for an extended time before start-up, increased protection against damage by corrosion or humidity can be achieved by observing the following information. The actual load depends very strongly on local conditions, therefore the time period stated is only a guide value. Note that this period does not include any extension of the warranty. If disassembly is necessary before start-up, contact Danfoss Service. The instructions contained in this document must be observed.

Check the factory-fitted plugs in all entry holes on the terminal box for damage caused during transportation and for correct positioning. Replace if necessary.

Repair any damage to the exterior paint layer or to the rust protection of the bright metal shafts, including hollow shafts.

The storage space should be dry, well-ventilated and vibration-free. If the temperature in the space exceeds the normal range of -20 °C to +40 °C for an extended period of time or varies strongly frequently, employ the measures

before start-up specified in 3.1 Measures before Commissioning, even after short storage times.

It is recommended that the drive units be turned 180° every 12 months so that the lubricant in the gear unit covers the bearings and gearwheels which have previously been positioned on top. Also, the output shaft should be turned manually in order to churn the rolling-contact bearing grease and distribute it evenly.

Turning the drive unit does not have to be carried out if the gear unit enclosure is completely filled with lubricant as the result of a special agreement. In this case, the lubricant level before start-up is to be reduced to the desired value as defined in the operating instructions and the nameplate.

### 6.3 Permanent Magnet Three-phase Synchronous Motor

Rated torque	12.6 Nm
Rated current	7.2 A
Rated speed	3000 rpm
Rated frequency	250 Hz
Motor circuit	Y
Winding resistance (R <sub>tt</sub> )	1Ω
Winding inductivity (L <sub>tt</sub> )	9 mH
Inductivity - D axis (L <sub>d</sub> )	5 mH
Inductivity - Q axis (L <sub>q</sub> )	5 mH
Motor poles (2p)	10
Moment of inertia	0.0043 Kgm <sup>2</sup>
Back EMF constant (k <sub>e</sub> )	120 V/1000 rpm
Torque constant (k <sub>t</sub> )	1.75 Nm/A

Table 6.1 Specifications

### 6.4 General Specifications and Environmental Conditions

Installation elevation	No derating (0%) up to 1000 m above NN. 10% derating for every 1000 m above 1000 NN.
Maximum backlash of gearbox unit	±0.07°

Table 6.2 General Specifications and Environmental Conditions



## 6.5 Electromagnetic Compatibility

The operation of the low-voltage machine in its intended application must meet the protection requirements of the EMC (electromagnetic compatibility) Directive 2004/108/EC. Correct installation (e.g. screened cables) is the responsibility of the system's installers. Precise information can be taken from the operation instructions. For systems with frequency inverters and rectifiers, the manufacturer's electromagnetic compatibility information must also be

taken into consideration. The electromagnetic compatibility directive in accordance with EN 61000-6-2 and EN 61000-6-4 is complied with given proper use and installation of the geared motors. This is also true in combination with Danfoss frequency inverters and rectifiers. The additional information provided in the operation instructions must be taken into consideration when using the motors in residential, commercial and trade sectors, as well as in small businesses in accordance with EN 61000-6-1 and EN 61000-6-3.

## 6.6 Dimensions

### 6.6.1 VLT® OneGearDrive Standard

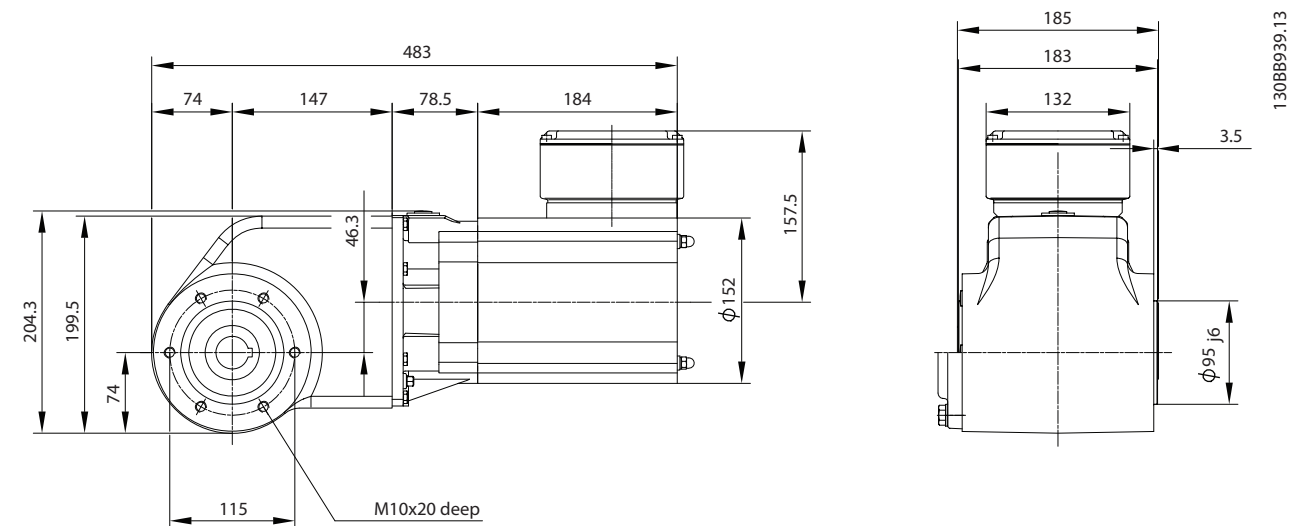

Illustration 6.2 VLT® OneGearDrive Standard

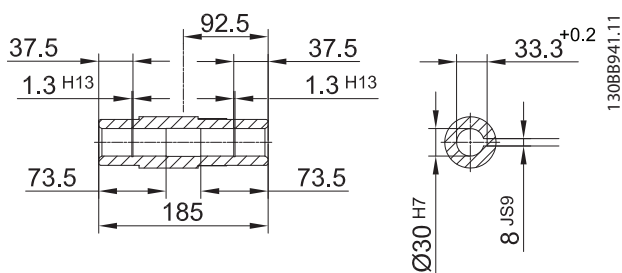

Illustration 6.3 Steel/Stainless Steel 30

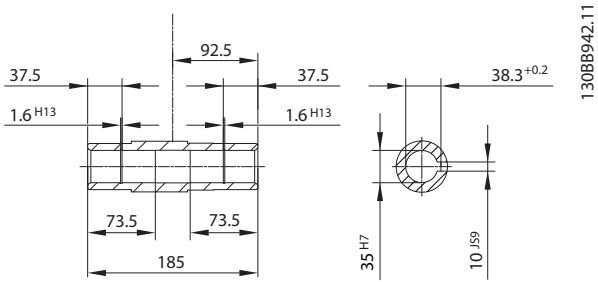

Illustration 6.4 Steel/Stainless Steel 35

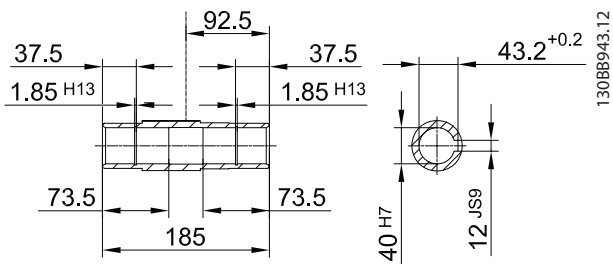

Illustration 6.5 Steel/Stainless Steel 40

6

### 6.6.2 VLT® OneGearDrive Standard with Torque Arm in Front Position (optional)

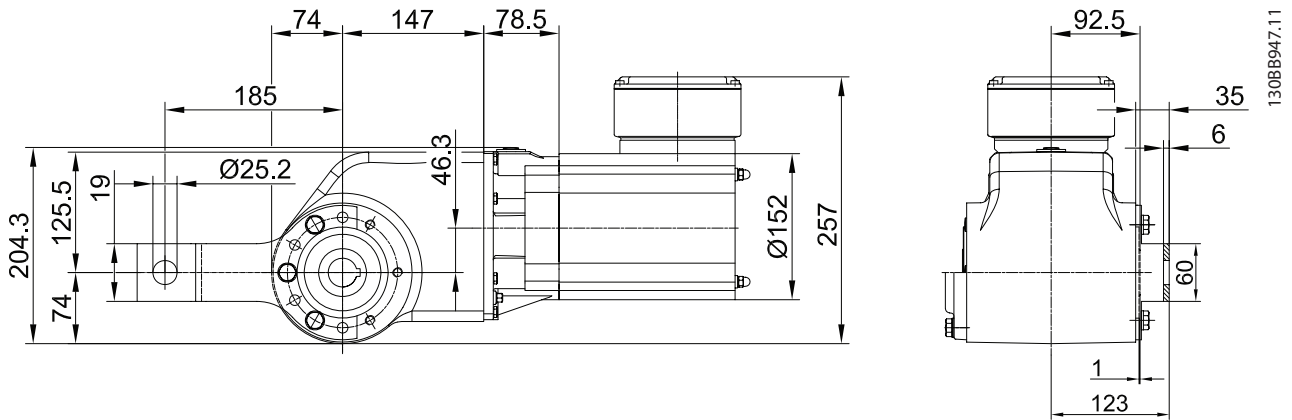

Illustration 6.6 Torque Arm in Front Position

6.6.3 VLT® OneGearDrive Hygienic

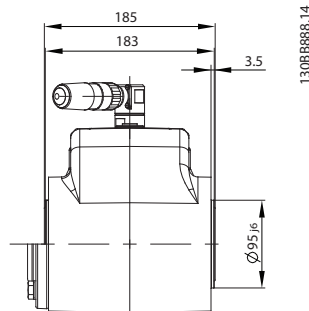
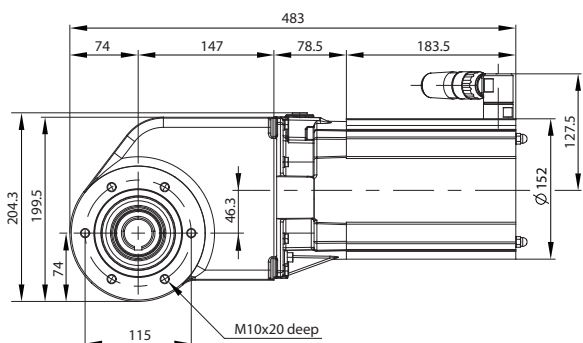

Illustration 6.7 VLT® OneGearDrive Hygienic

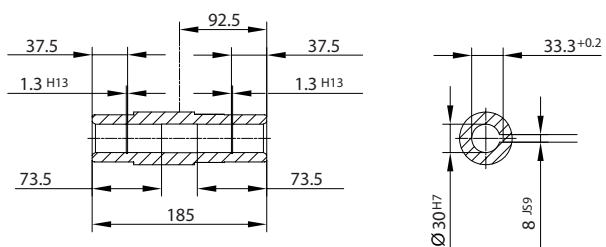

Illustration 6.8 Stainless Steel 30

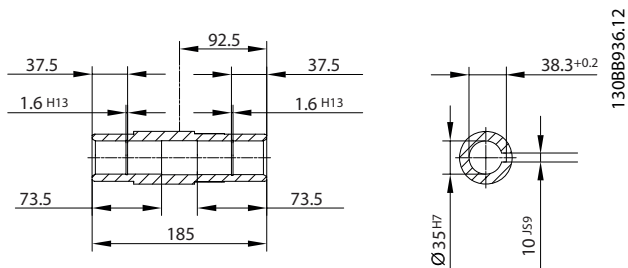

Illustration 6.9 Stainless Steel 35

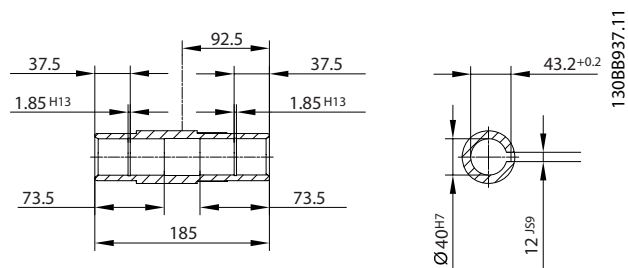

Illustration 6.10 Stainless Steel 40

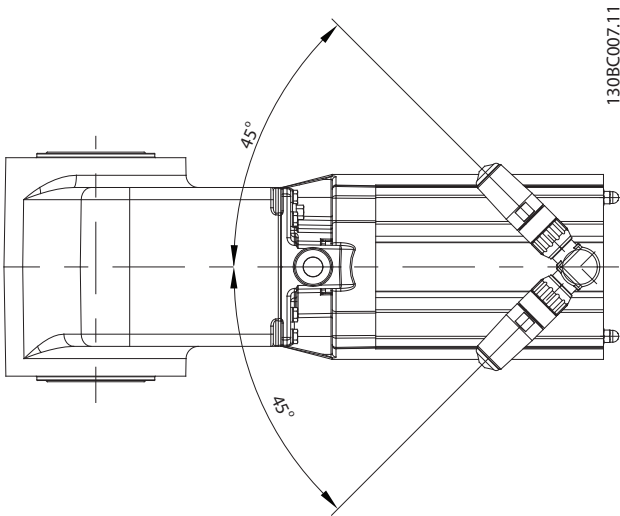

Illustration 6.11 Connector Position

## CAUTION

Never turn the CleanConnect plug more than 45° clockwise or anti-clockwise from the delivered middle axis (0°) as shown in *Illustration 6.11*.

If the plug is rotated more than the permitted 45°, the cables could be damaged, causing a short-circuit.

### 6.6.4 VLT® OneGearDrive Hygienic with Torque Arm in Front Position (optional)

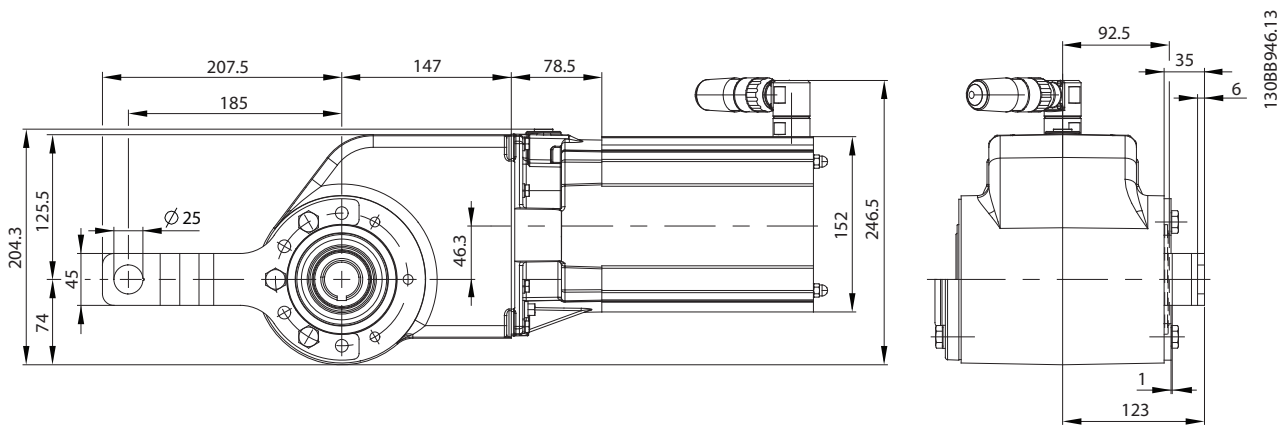
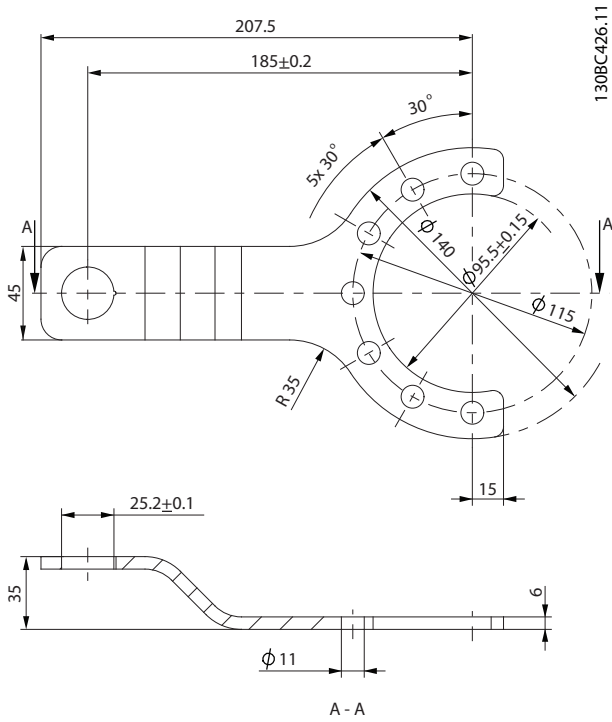

Illustration 6.12 Torque Arm in Front Position

## 6.7 Options

### 6.7.1 Torque Arm Set

Part number: 178H5006



6

Illustration 6.13 Torque Arm

6

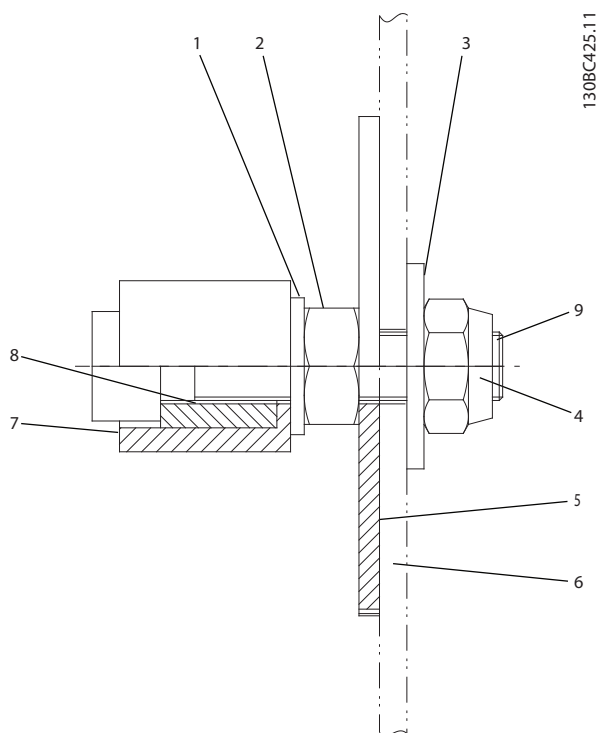

Illustration 6.14 Mounting Set

Position	Description	Specification
1	Disc	DIN 125-A10 5
2	Nut	DIN 934 M10
3	Disc	DIN 9021 10, 5x30x25
4	Nut	DIN 985 M10
5	Disc	Ø73x3 Stainless steel
6	Customer Frame	-
7	Barrel	POM-C white
8	Bushing	Stainless Steel
9	Screw	Stainless Steel

Table 6.3 Legend to *Illustration 6.14*

**NOTE**

The set also contains 3 x DIN 933, M10x25, 8.8, stainless steel screws. The tightening torque is 49 Nm.

**CAUTION**

Only use the original Danfoss or comparable mounting set to mount the VLT® OneGearDrive to the conveyor. The mounting equipment used must ensure the same degree of flexibility as the original Danfoss mounting set. The torque arm cannot be screwed directly on to the conveyor frame.

## 6.7.2 Mechanical Brake

## 6.7.2.2 Technical Data

### 6.7.2.1 Overview

The VLT® OneGearDrive Standard is available with a 180 V DC brake option. This mechanical brake option is intended for emergency stop and park brake duty. Normal braking of a load is still controlled by the inverter dynamic brake.

Spring-loaded brakes are safety brakes, which continue to work in the event of power failure or usual wear. Since other components could also fail, take suitable safety precautions to avoid any injury to persons or damage to objects caused by unbraked operation.

### **⚠ WARNING**

**Danger of fatal injury if the hoist falls.  
Severe or fatal injuries.**

- The brake must not be used in vertical lifting and hoisting applications.

### 6.7.2.3 Dimensions

Illustration 6.15 shows the dimensions of the VLT® OneGearDrive with the mechanical brake option.

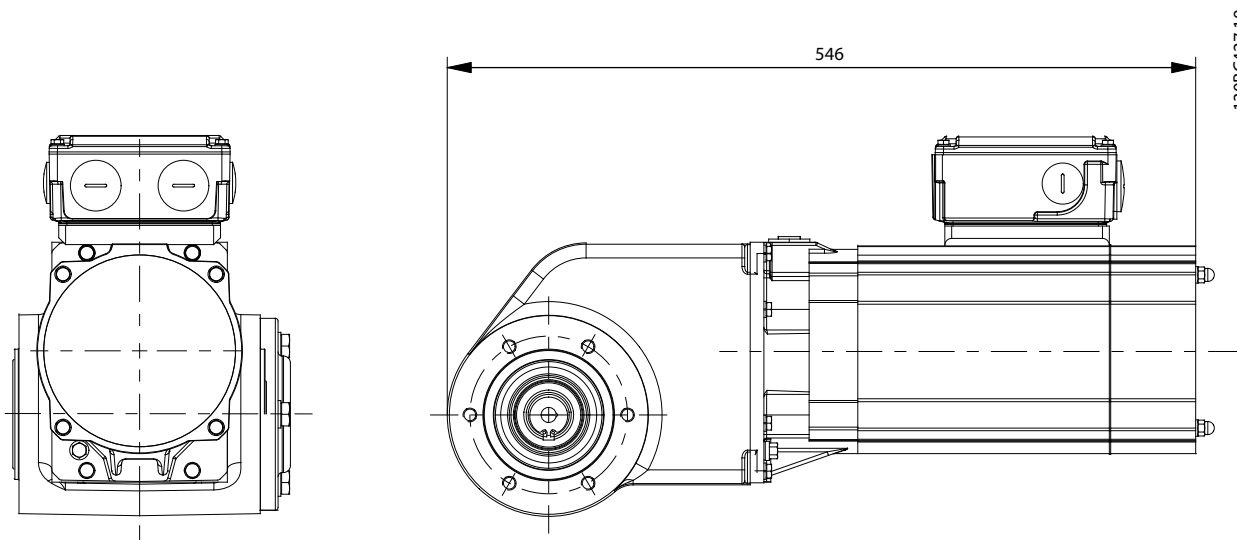

Illustration 6.15 Dimensions of the VLT® OneGearDrive with Mechanical Brake Option

Voltage	V <sub>DC</sub>	180 ±10 %
P <sub>el</sub>	W	14.4
Resistance	Ω	2250 ±5 %
Current	A	0.08
Maximum brake torque	Nm	10

Table 6.4 Specification: Mechanical Brake Option

6.7.2.4 Connections

Illustration 6.16 shows the cage clamp and the connection to AutomationDrive FC 302.

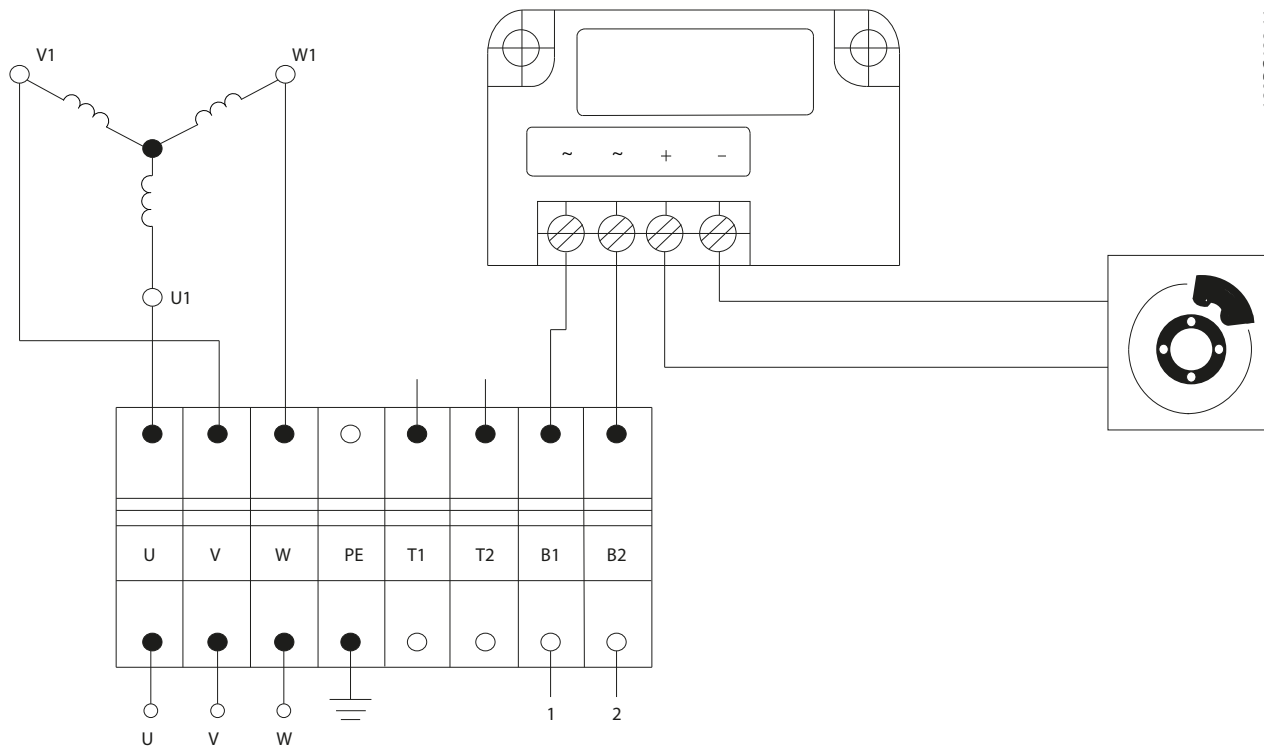

130BC428.11

6

Illustration 6.16 Cage Clamp and Connection to AutomationDrive FC 302.

Description	Coding	Pin	Colour	Typical cross section	Maximum cross section	VLT® AutomationDrive FC 302	VLT® Decentral Drive FCD 302	External DC power supply
Brake power supply	B1	1	Brown	AWG 20/ 0.75 mm <sup>2</sup>	AWG 14/ 2.5 mm <sup>2</sup>	400 V AC power supply	Terminal 122 (MBR+)	+
	B2	2	Black			Terminal 04	Terminal 123 (MBR-)	-

Table 6.5 Mechanical Brake Option Connections

NOTE

Connect terminal 05 on the VLT® AutomationDrive FC 302 to the 400 V AC power supply.

The connection and use of the mechanical brake has been tested and released with VLT® AutomationDrive FC 302 and VLT® Decentral Drive FCD 302. Any other inverter may require a different connection. Contact Danfoss Service for further information.

For information about parameter setting and programming when using VLT® AutomationDrive FC 302 or VLT® Decentral Drive FCD 302, refer to the corresponding Operating Instructions.



## 6.8 Accessories

### 6.8.1 Accessories for VLT® OneGearDrive Standard

VLT® OneGearDrive Standard	Ordering Number
Torque arm, stainless steel	178H5006

Table 6.6 Accessories for VLT® OneGearDrive Standard

### 6.8.2 Accessories for VLT® OneGearDrive Hygienic

VLT® OneGearDrive Hygienic	Ordering Number
Motor connector without cable	178H1613
Motor connector with 5 m cable	178H1630
Motor connector with 10 m cable	178H1631
Torque arm, stainless steel	178H5006

Table 6.7 Accessories for VLT® OneGearDrive Hygienic

**Index**

**A**

Accessories..... 31

Approvals..... 4

Axial Fastening..... 9

**B**

**Brake:**

Dimensions..... 29

Maintenance..... 16

Overview..... 29

Braking Torque (Nominal)..... 17

**C**

Cage Clamp Connection..... 12

Commissioning..... 15

**Connection:**

Cage Clamp..... 12

Electrical..... 10

Mechanical Brake Option..... 30

Safety..... 11

Three-phase Gear Motors..... 13

Current (rated)..... 22

**D**

Damage To Surface..... 7

Decommissioning..... 21

**Dimensions:**

Mechanical Brake Option..... 29

VLT® OneGearDrive Hygienic..... 25

VLT® OneGearDrive Hygienic With Torque Arm In Front Position..... 26

VLT® OneGearDrive Standard..... 23

VLT® OneGearDrive Standard With Torque Arm In Front Position..... 24

Discharge Time..... 16

Disposal Of Parts..... 21

Due Diligence..... 6

**E**

Electrical Connection, Safety..... 10

Electromagnetic Compatibility..... 23

**F**

Faults, Safety..... 17

Frequency (rated)..... 22

**I**

Inductivity..... 22

Inertia..... 22

Intended Use..... 6

**L**

**Lubricant:**

Change Intervals..... 18

Gear Unit..... 15

Grades..... 18

How To Change..... 20

Types..... 18

Volume..... 19

**M**

**Maintenance**..... 16

**Mechanical**

Brake Option: Connection..... 30

Brake Option: Dimensions..... 29

Brake Option: Maintenance..... 16

Brake Option: Overview..... 29

Brake Option: Springs..... 17

Brake Option: Technical Data..... 29

**Misuse Of The Product**..... 6

**Motor**

Circuit..... 22

Torque..... 22

**Mounting**

Mounting..... 7

Arrangement..... 7

Set For Torque Arm..... 27

**N**

**Nameplate**..... 22

**O**

**Oil:**

Change Intervals..... 18

Grades..... 18

How To Change..... 20

Types..... 18

Volume..... 19

**Options**..... 27

**Overload Protection**..... 14

**P**

**Protection**

Protection..... 7

Against Overload..... 14

**Protective Coating**..... 7

**R**

**Rating Plate**..... 22

**Recycling**..... 21

**S**

**Safety Discharge Time**..... 16

<b>Safety:</b>	
Connection.....	11
Faults.....	17
General.....	5
Intended Use.....	6
Mounting.....	7
Personnel.....	5
<b>Shaft Seals.....</b>	<b>15</b>
<b>Spare Parts.....</b>	<b>20</b>
<b>Speed (rated).....</b>	<b>22</b>
<b>Springs (Brake).....</b>	<b>17</b>
<b>Start-up: Measures Before Commissioning.....</b>	<b>15</b>
<b>Storage.....</b>	<b>5, 22</b>
<b>Storage:</b>	
Conditions.....	22
Measures During Storage.....	22
<b>Surface Damage.....</b>	<b>7</b>
<b>T</b>	
<b>Technical Data: Motor.....</b>	<b>22</b>
<b>Terminal Box.....</b>	<b>11</b>
<b>Three-phase Gear Motors, Connection.....</b>	<b>13</b>
<b>Torque</b>	
Arm Set.....	27
Mounting Set.....	27
Restraint.....	10
<b>Torque: Motor.....</b>	<b>22</b>
<b>Transportation.....</b>	<b>5</b>
<b>W</b>	
<b>Warning Discharge Time.....</b>	<b>16</b>
<b>Winding.....</b>	<b>22</b>



[www.danfoss.com/drives](http://www.danfoss.com/drives)

---

Danfoss can accept no responsibility for possible errors in catalogues, brochures and other printed material. Danfoss reserves the right to alter its products without notice. This also applies to products already on order provided that such alterations can be made without subsequential changes being necessary in specifications already agreed. All trademarks in this material are property of the respective companies. Danfoss and the Danfoss logotype are trademarks of Danfoss A/S. All rights reserved.

---

