

Installation Instructions

Mounting Adapter to VLT[®] 2800

VLT[®] Midi Drive FC 280

The instructions provide information about installation of the mounting adapter for exchanging a VLT[®] 2800 with a VLT[®] Midi Drive FC 280.

Only Danfoss authorized, qualified personnel is allowed to install this equipment. The personnel must be familiar with the instructions and safety measures described in the *VLT[®] Midi Drive FC 280 Operating Guide*.

Items Supplied

Four different mounting adapters are available. Each adapter comes with either 4 or 8 screws, depending on the type of adapter.

- Mounting adapter 1
 - 4 screws size M4x12
- Mounting adapter 2
 - 4 screws size M4x20
 - 4 screws size M5x20
- Mounting adapter 3
 - 4 screws size M5x20
- Mounting adapter 4
 - 4 screws size M6x20

Mounting adapter	Enclosure	Corresponding VLT [®] 2800	Ordering number
Adapter A	K1	Size A	132B0363
Adapter B	K1/K2	Size B	132B0364
Adapter C	K2/K3	Size C	132B0365
Adapter D	K4/K5	Size D	132B0366

Tools Required

- Screwdrivers:
 - T20

Safety Instructions

⚠ WARNING

DISCHARGE TIME

The frequency converter contains DC-link capacitors, which can remain charged even when the frequency converter is not powered. High voltage can be present even when the warning LED indicator lights are off. Failure to wait the specified time after power has been removed before performing service or repair work can result in death or serious injury.

- Stop the motor.
- Disconnect AC mains and remote DC-link supplies, including battery back-ups, UPS, and DC-link connections to other frequency converters.
- Disconnect or lock PM motor.
- Wait for the capacitors to discharge fully. The minimum waiting time is specified in *Table 1.1*.
- Before performing any service or repair work, use an appropriate voltage measuring device to make sure that the capacitors are fully discharged.

Voltage [V]	Power range [kW (hp)]	Minimum waiting time (minutes)
200–240	0.37–3.7 (0.5–5)	4
380–480	0.37–7.5 (0.5–10)	4
	11–22 (15–30)	15

Table 1.1 Discharge Time

Installation

NOTICE

For dimensions of the various adapter plates, refer to *Illustration 1.1* to *Illustration 1.4*.

1. Using the mounting holes and screws from the old frequency converter, securely fasten the adapter plate.
2. Mount the supplied screws.
3. Position the frequency converter and slide it onto the adapter plate screws.

Mounting adapter A

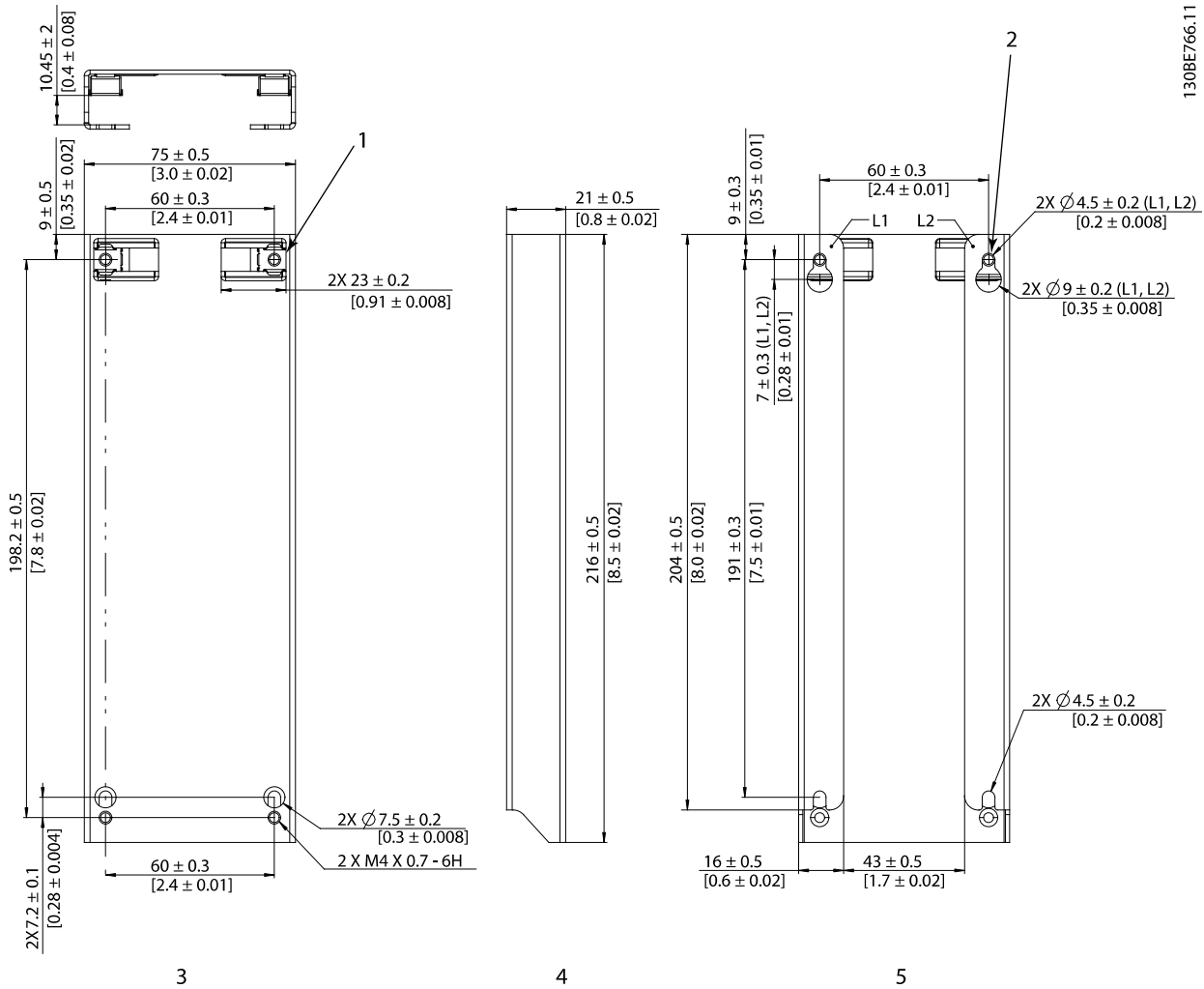

130BE766.11

1	Mounting holes for the frequency converter. Use the screws supplied with the adapter plate.	4	Side view
2	Mounting holes for the adapter plate. Use the screws from the VLT® 2800.	5	Back view
3	Front view		

Illustration 1.1 Dimensions for Mounting Adapter A, Units in mm [in]

Mounting adapter B

130BE767.11

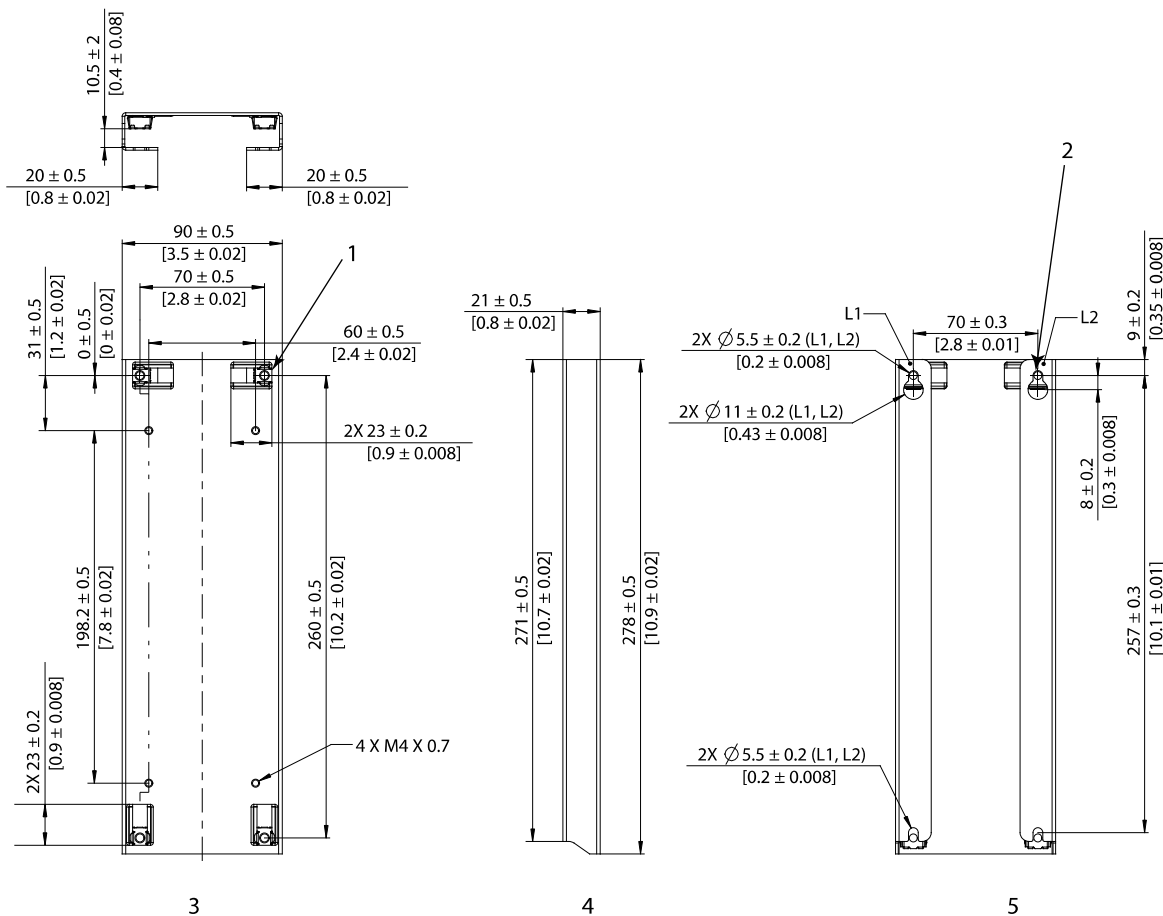

1	Mounting holes for the frequency converter. Use the screws supplied with the adapter plate.	4	Side view
2	Mounting holes for the adapter plate. Use the screws from the VLT® 2800.	5	Back view
3	Front view		

Illustration 1.2 Dimensions for Mounting Adapter B, Units in mm [in]

Mounting adapter C

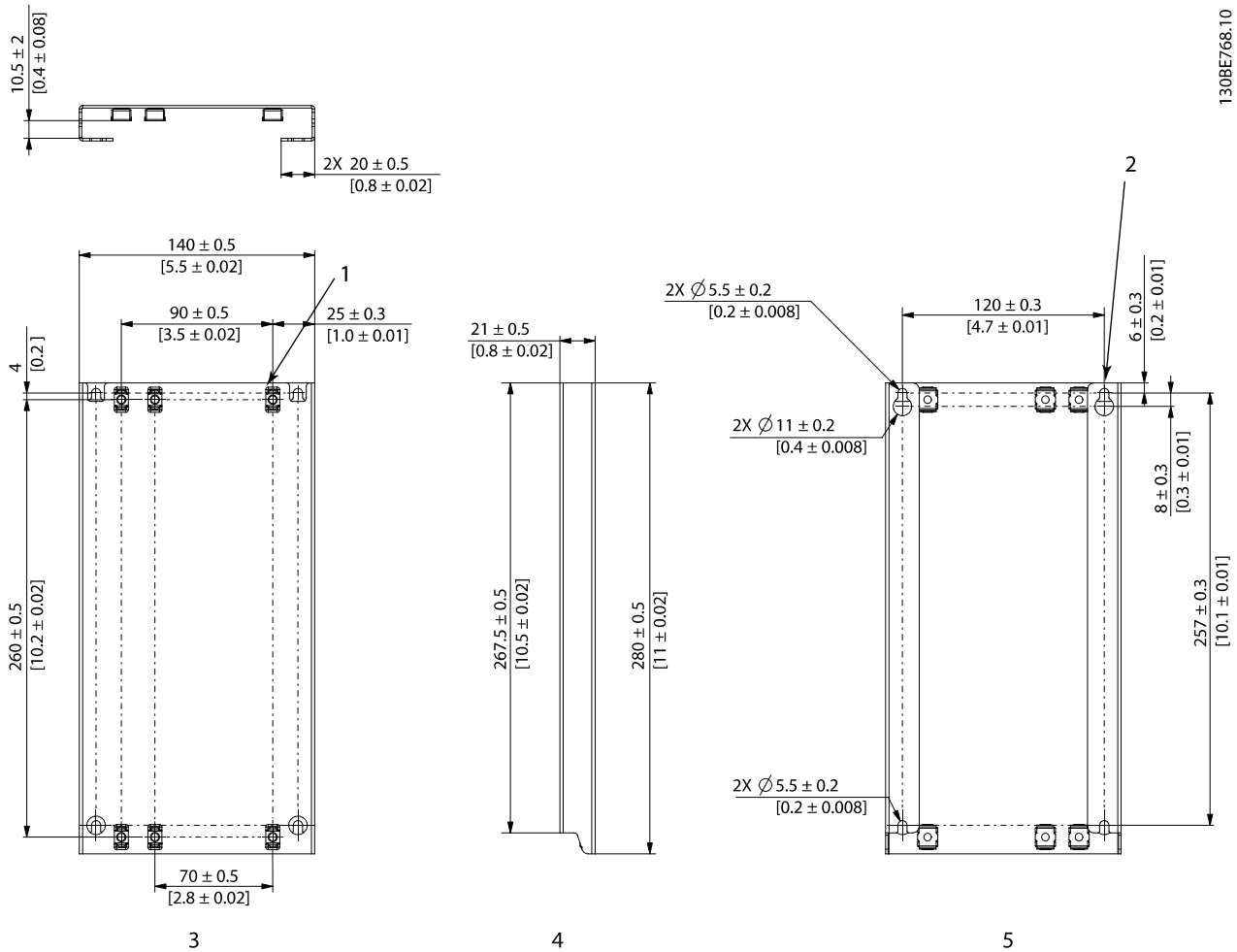

130BE768.10

1	Mounting holes for the frequency converter. Use the screws supplied with the adapter plate.	4	Side view
2	Mounting holes for the adapter plate. Use the screws from the VLT® 2800.	5	Back view
3	Front view		

Illustration 1.3 Dimensions for Mounting Adapter C, Units in mm [in]

Mounting adapter D

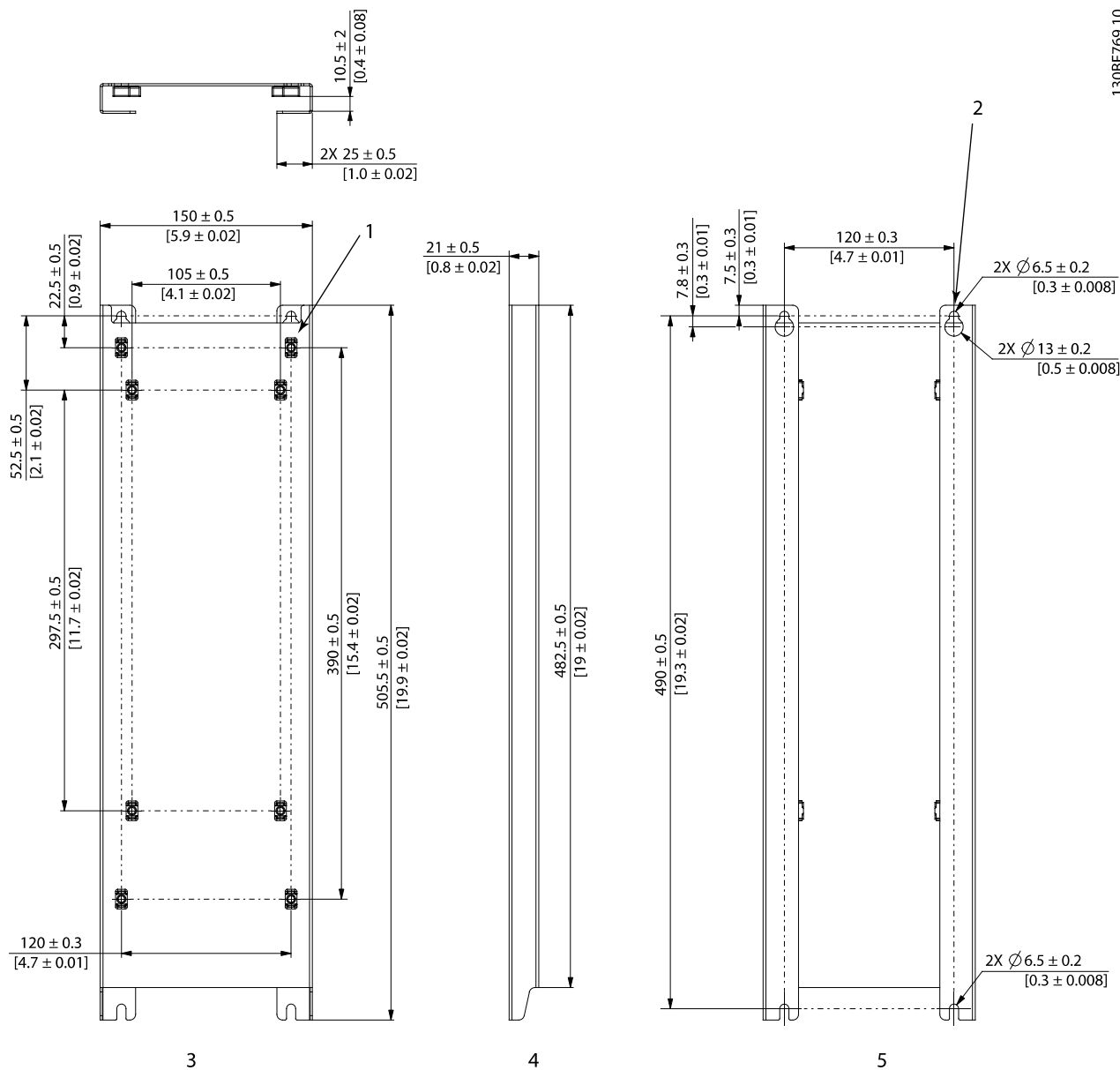

130BE769.10

1	Mounting holes for the frequency converter. Use the screws supplied with the adapter plate.	4	Side view
2	Mounting holes for the adapter plate. Use the screws from the VLT® 2800.	5	Back view
3	Front view		

Illustration 1.4 Dimensions for Mounting Adapter D, Units in mm [in]

.....
Danfoss can accept no responsibility for possible errors in catalogues, brochures and other printed material. Danfoss reserves the right to alter its products without notice. This also applies to products already on order provided that such alterations can be made without subsequential changes being necessary in specifications already agreed. All trademarks in this material are property of the respective companies. Danfoss and the Danfoss logotype are trademarks of Danfoss A/S. All rights reserved.
.....

Danfoss A/S
Ulsnaes 1
DK-6300 Graasten
vlt-drives.danfoss.com

