

Installation Instructions

In-back/Out-top Cooling Kit for E3h/E4h Drives

VLT[®] FC Series FC 102, FC 103, FC 202, and FC 302

1.1 Description

The in-back/out-top cooling kit fits the following E3h and E4h drives. It is compatible with drives mounted in Rittal TS8 cabinets with widths of 600 mm (24 in) or 800 mm (32 in).

- VLT[®] HVAC Drive FC 102
- VLT[®] Refrigeration Drive FC 103
- VLT[®] AQUA Drive FC 202
- VLT[®] Automation Drive FC 302

When the kit is installed, air flows into the back duct and out through the top duct of the drive. See *Illustration 1.1*.

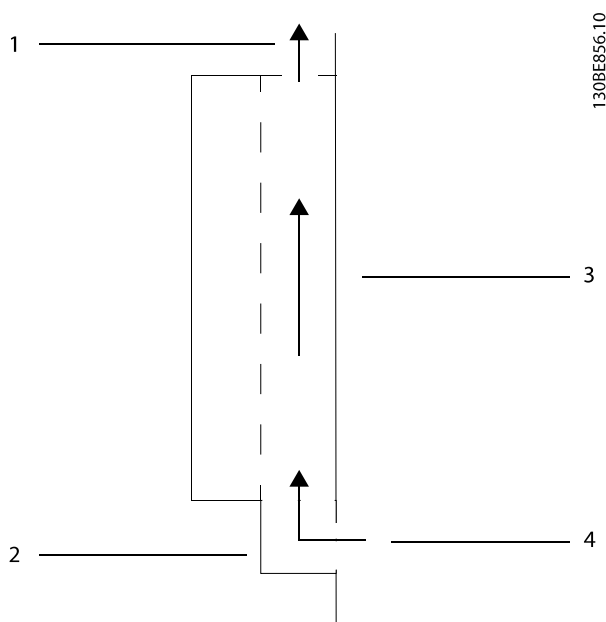

1	Top duct (exhaust)
2	Cooling back channel
3	Airflow direction
4	Bottom duct (intake)

Illustration 1.1 Direction of Airflow with Kit Installed

1.1.1 Kit Part Numbers

Use these instructions with the following cooling kits.

Kit number	Kit description
176F6615	In-back/out-top cooling kit for E3h drive
176F6616	In-back/out-top cooling kit for E4h drive

Table 1.1 Part Numbers for Cooling Kits

1.1.2 Items Supplied

The in-back/out-top cooling kit contains the following items.

Item	Quantity
Bottom cover	1
Bottom gasket	1
Top duct assembly	1
Back duct	1
6-hole back gasket	2
8-hole back gasket	2
Clip-on nuts	8
M6x12 screws	6
M5x18 screws	8
M5x14 screws	8–10
M5 hex nuts	6

Table 1.2 Items Supplied in Cooling Kit

1.2 Safety Information

Only qualified, Danfoss authorized personnel are allowed to install the parts described in these installation instructions. Handling of the drive and its parts must be done in accordance with the corresponding *operating guide*.

⚠ WARNING**ELECTRICAL SHOCK HAZARD**

VLT® FC series drives contain dangerous voltages when connected to mains voltage. Improper installation, and installing or servicing with power connected, can cause death, serious injury, or equipment failure.

To avoid death, serious injury, or equipment failure:

- Only use qualified electricians for the installation.
- Disconnect the drive from all power sources before installation or service.
- Treat the drive as live whenever the mains voltage is connected.
- Follow the guidelines in these instructions and local electrical safety codes.

⚠ WARNING**DISCHARGE TIME**

The drive contains DC-link capacitors, which can remain charged even when the drive is not powered. High voltage can be present even when the warning LED indicator lights are off. Failure to wait 40 minutes after power has been removed before performing service or repair work can result in death or serious injury.

- Stop the motor.
- Disconnect AC mains and remote DC-link power supplies, including battery back-ups, UPS, and DC-link connections to other drives.
- Disconnect or lock PM motor.
- Wait 40 minutes for capacitors to discharge fully.
- Before performing any service or repair work, use an appropriate voltage measuring device to make sure that the capacitors are fully discharged.

1.3 Installation Instructions

NOTICE

APPLYING GASKETS

This kit contains gaskets to ensure a proper seal between metal parts. Before adhering a gasket to a part, check that the part matches the gasket and that no holes are covered.

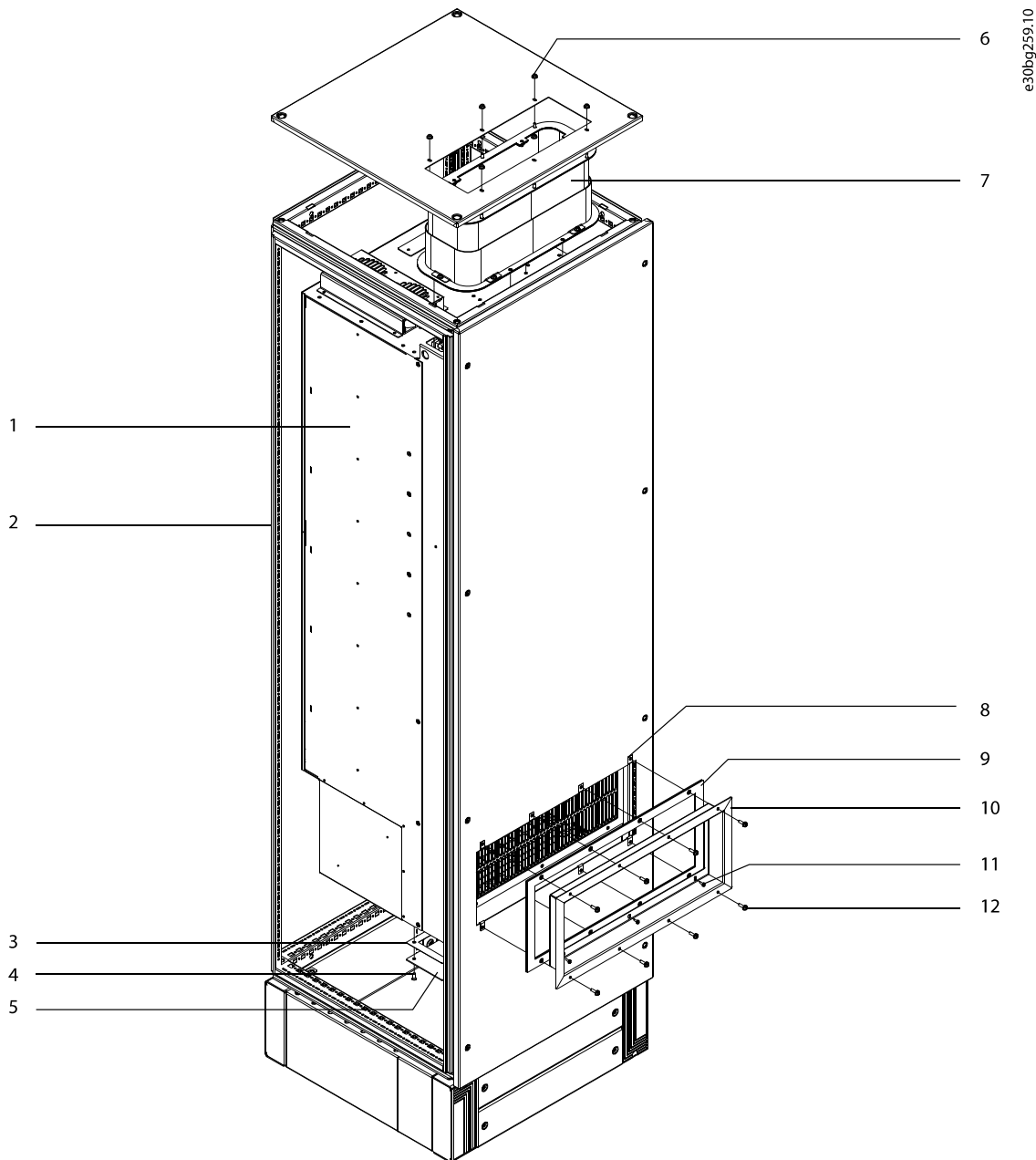

1	Drive	7	Top duct assembly
2	Rittal enclosure	8	Clip-on nut
3	Bottom gasket	9	Back gasket
4	M5x14 screw	10	Back duct
5	Bottom cover	11	M6x12 screw
6	M5 hex nut	12	M5x18 screw

Illustration 1.2 Overview of In-back/Out-top Cooling Kit

1.3.1 Creating Vent Openings in the Mounting Plate

To create mounting holes and a back vent opening in the drive mounting plate, use the following steps. Refer to *Illustration 1.3* for 600 mm (24 in) enclosures, or *Illustration 1.4* for 800 mm (32 in) enclosures.

1. Drill 6 mounting holes in the back of the drive using the dimensions in *Illustration 1.3* or *Illustration 1.4*. Insert 6 M10 pem self-clinching nuts (not supplied) in the mounting holes.
2. Cut out the vent opening in the mounting plate. The opening must match the drive vent opening.
3. Drill 6 screw holes around the vent opening. The holes must match the holes in the inner flange of the back duct.

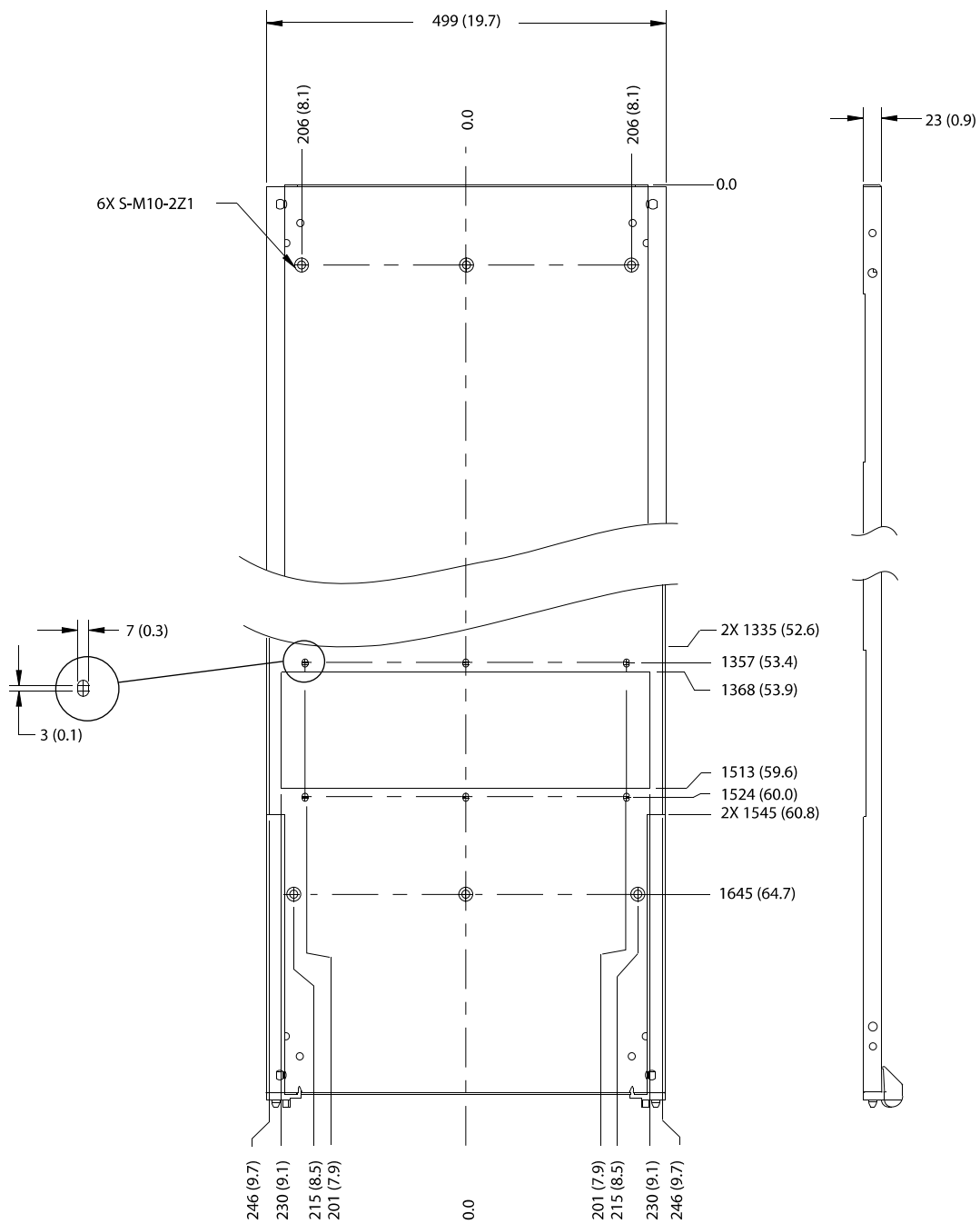

e30bg255.10

Illustration 1.3 Vent Dimensions for Mounting Plate in 600 mm (24 in) Enclosure

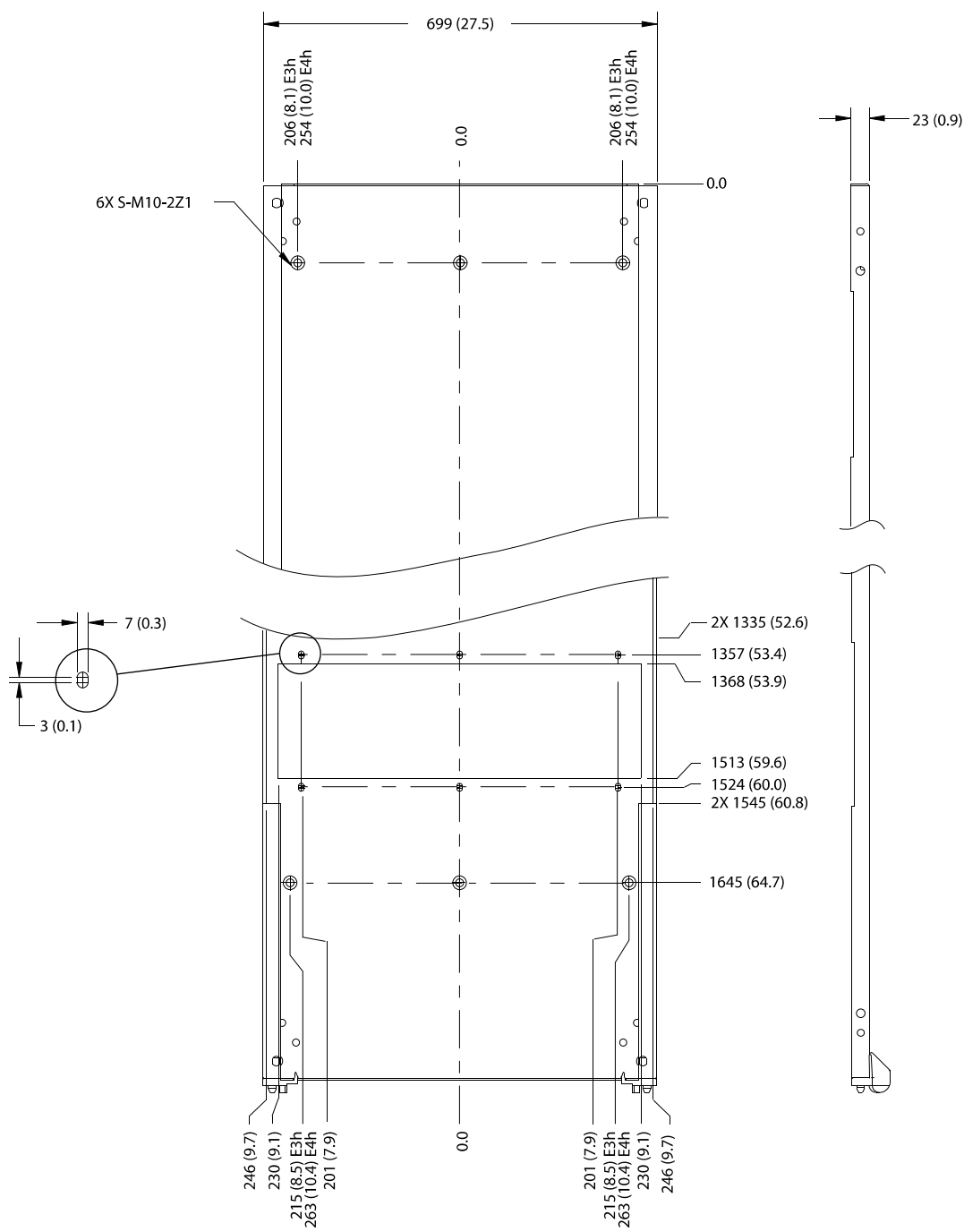

e30bg256.10

Illustration 1.4 Vent Dimensions for Mounting Plate in 800 mm (32 in) Enclosure

1.3.2 Creating Vent Openings in the Backplate

To create a vent opening in the enclosure backplate to match the opening in the mounting plate and drive, use the following steps. Refer to *Illustration 1.5* for 600 mm (24 in) enclosures, or *Illustration 1.6* for 800 mm (32 in) enclosures.

1. Cut out the vent opening in the enclosure backplate. The opening must match the drive vent opening.
2. Drill 8 screw holes (6 mm) around the vent opening. The holes must match the holes in the outer flange of the back duct.

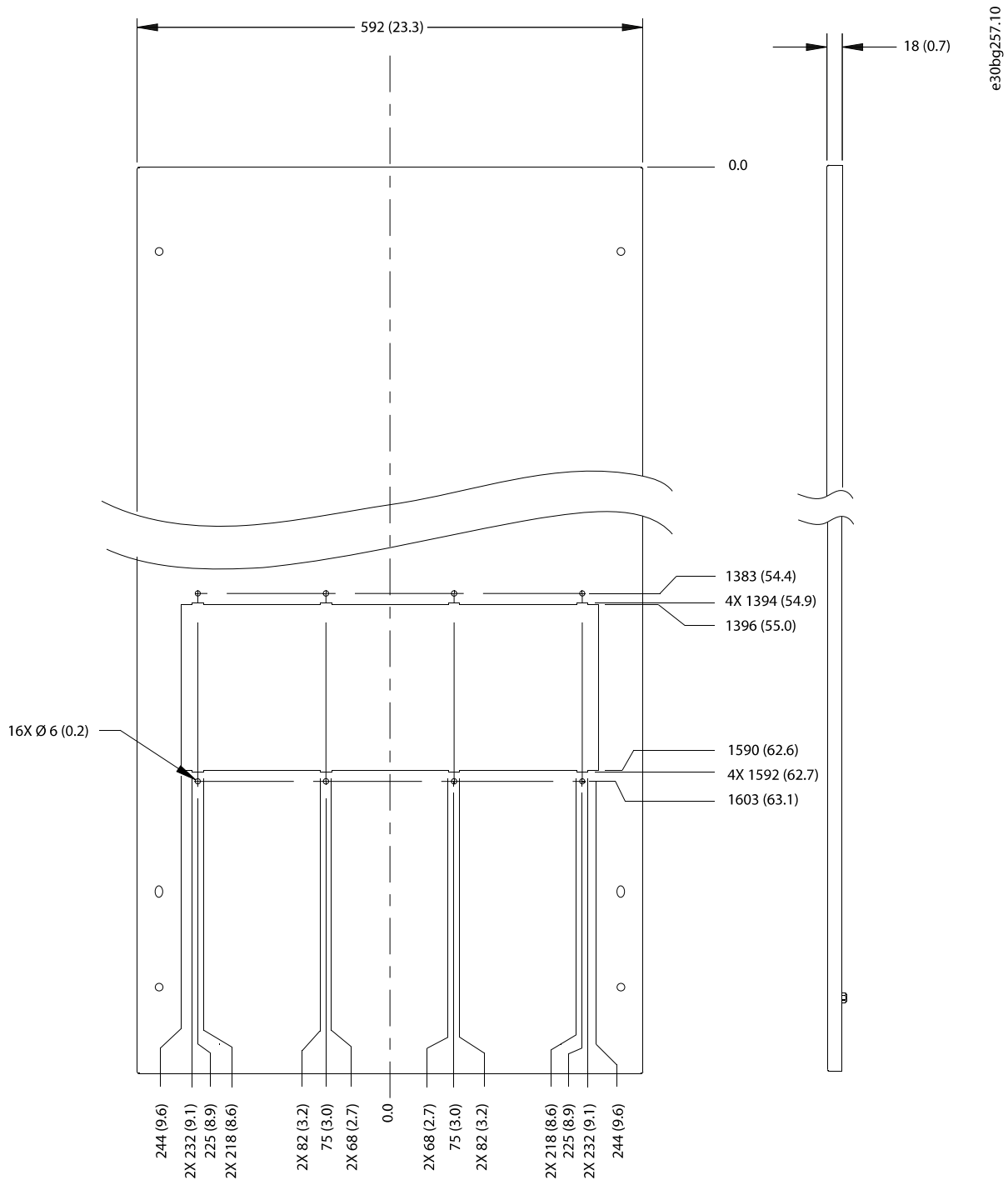
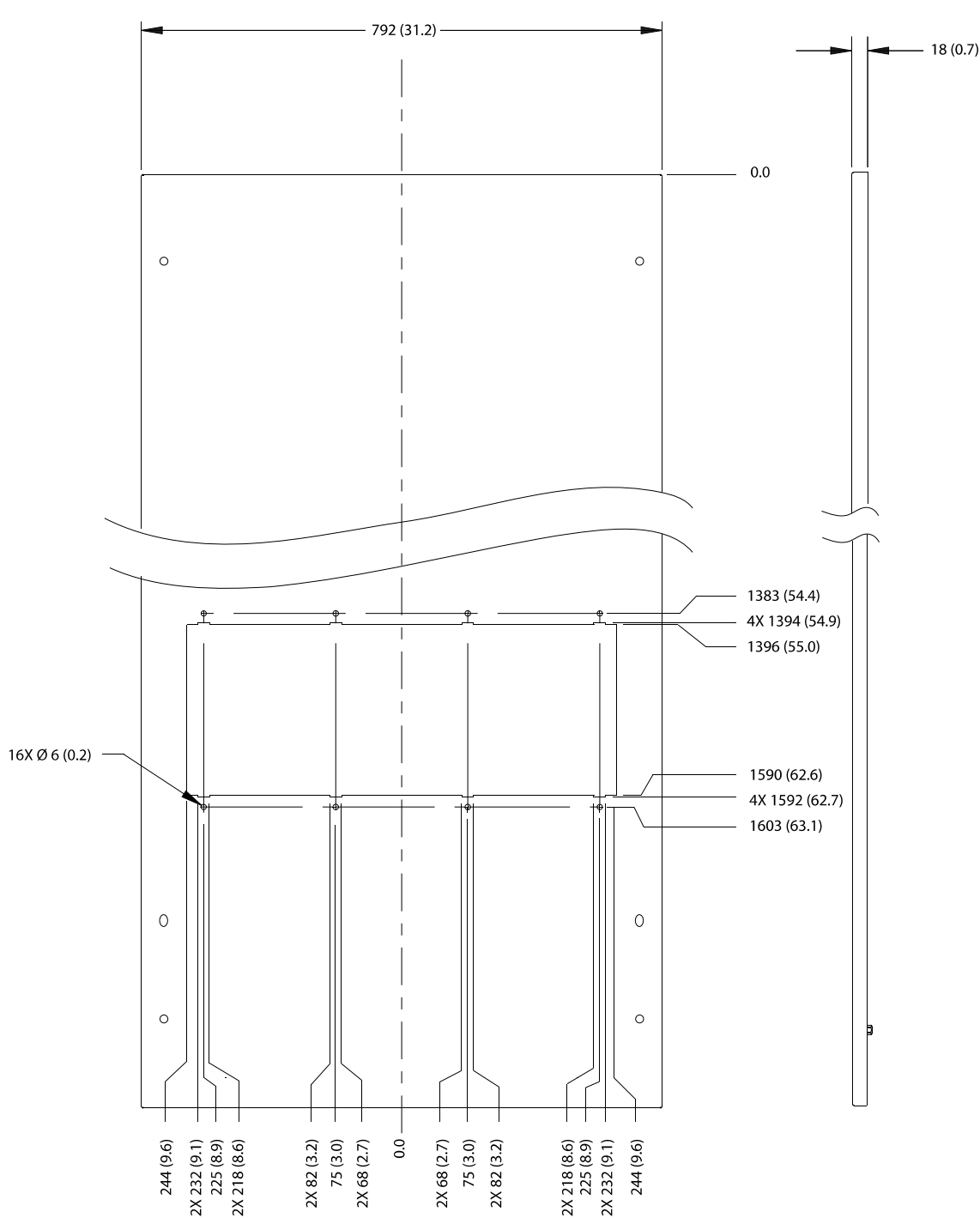

Illustration 1.5 Vent Dimensions for Backplate in 600 mm (24 in) Enclosure



e30bg258.10

Illustration 1.6 Vent Dimensions for Backplate in 800 mm (32 in) Enclosure

1.3.3 Creating a Vent Opening in the Enclosure Top Plate

To create a vent opening in the enclosure top plate to match the top vent of the drive and top duct, use the following steps. Refer to *Illustration 1.7* and *Illustration 1.8*.

1. Cut out the vent opening in the enclosure top plate. The opening must match the drive vent opening.
2. Drill 6 screw holes (6 mm) around the vent opening. The holes must match the holes in the upper flange of the top duct.

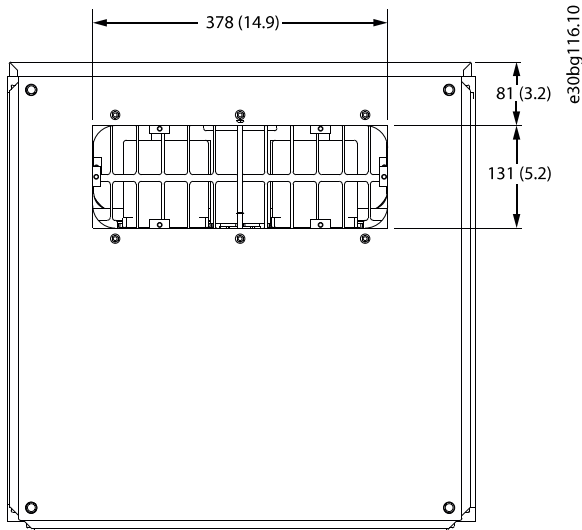

Illustration 1.7 Dimensions of Vent in Top of Drive

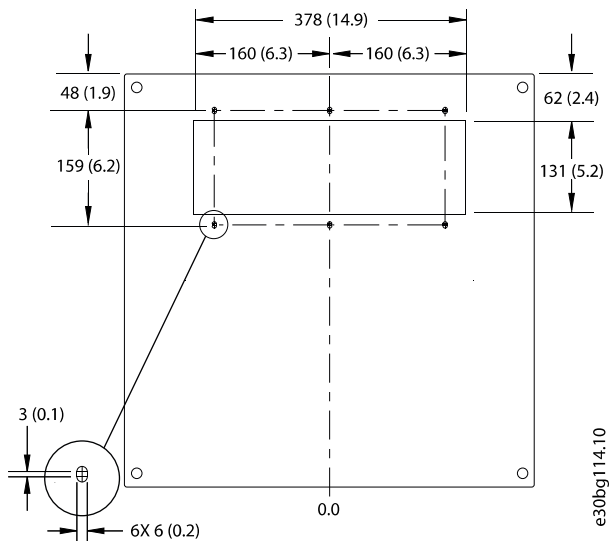
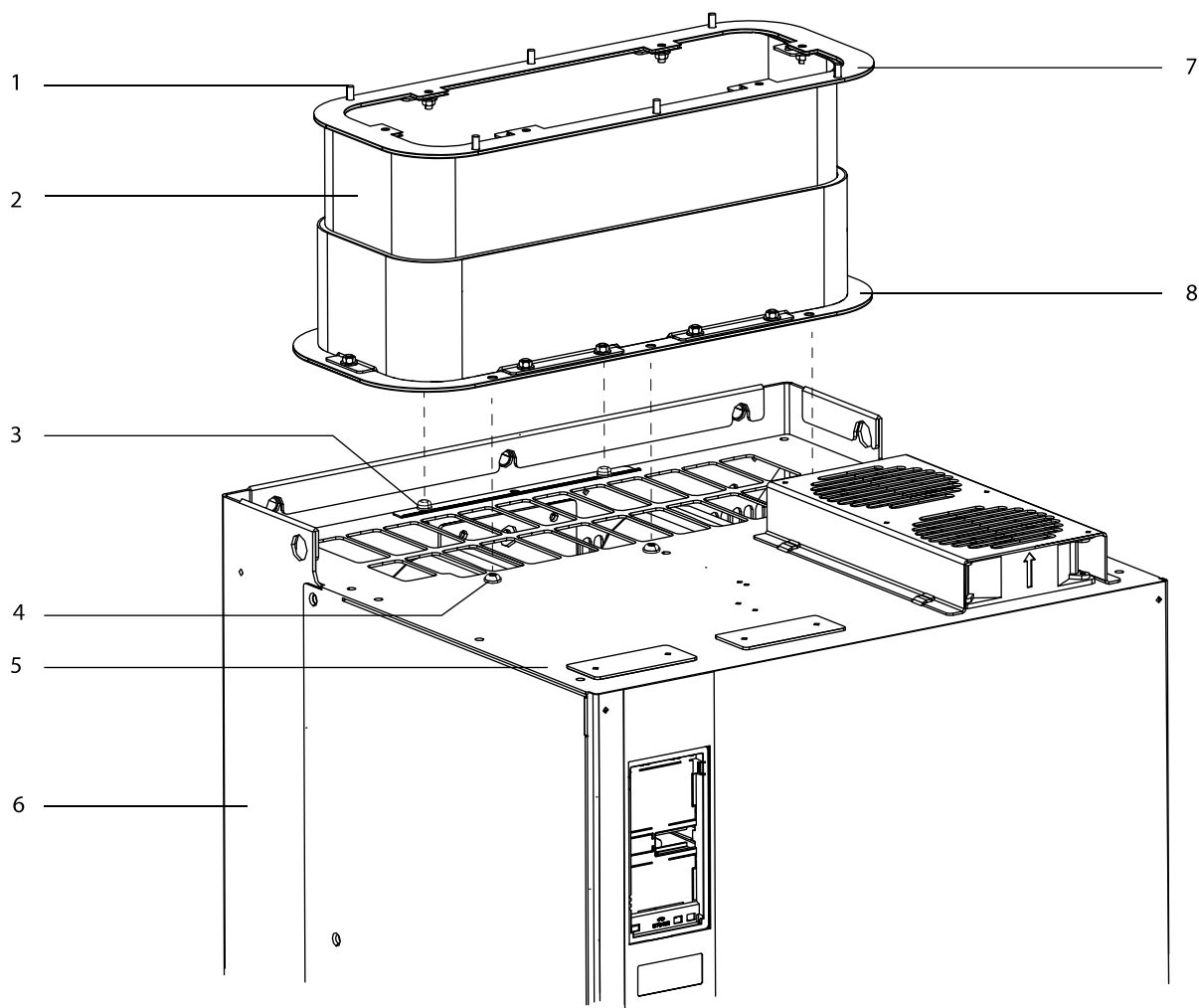

Illustration 1.8 Dimensions for Opening in Enclosure Top Plate

1.3.4 Installing the Top Duct Over the Drive Top Vent

The top duct is a pre-assembled, telescoping duct that collapses to simplify installation. To attach the top duct over the top vent of the drive, use the following procedure. See *Illustration 1.9*.

1. Remove 2 M5x14 screws (T25) at the back of the vent in the top of the drive. Retain the screws.
2. Remove 3 M5x12 screws (T25) at the front of the vent in the top of the drive. Retain the screws.
3. Position the top duct over the vent in the top of the drive. Line up the holes in the lower flange with the screw holes in the drive.
4. Secure the lower flange to the drive with the 5 screws (T25) previously removed. Torque fasteners to 2.3 Nm (20 in-lb).
5. Collapse the duct until installation of the enclosure top plate.



e30bg232.10

1	Threaded stud	5	Top of drive
2	Top duct	6	Cooling back channel
3	M5x14 screw	7	Upper flange of duct
4	M5x12 screw	8	Lower flange of duct

Illustration 1.9 Installation of the Top Duct Over the Top Vent of the Drive

1.3.5 Installing the Bottom Cover

NOTICE

DRAIN OPENING

The bottom cover features a drain opening in the middle of the plate. To drain moisture in wet or humid environments, attach nylon tubing with interior diameter of 8 mm (0.3 in). To seal the drain in dry environments, fasten a screw in the drain hole.

To install the bottom cover at the lower end of the cooling back channel, use the following procedure. See *Illustration 1.10*.

1. Remove paper backing from the bottom gasket. Adhere the bottom gasket to the upper side of the bottom cover.
2. Position the bottom cover and gasket over the opening at the lower end of the cooling channel.
3. Secure the bottom cover using the M5x14 screws (T25) provided with the kit. Installation in E3h drives requires 8 screws, and installation in E4h drives requires 10 screws. Torque screws to 2.3 Nm (20 in-lb).

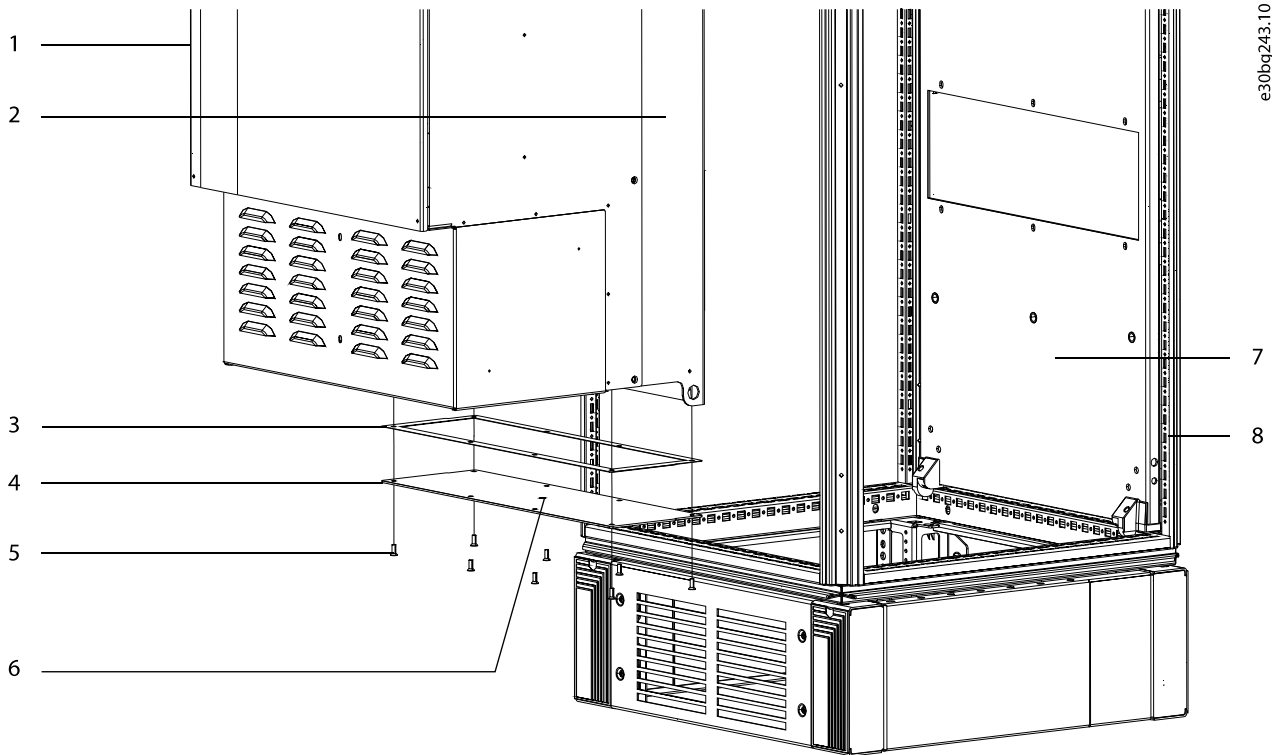

1	Drive	5	M5x14 screws
2	Cooling back channel	6	Drain hole
3	Bottom gasket	7	Mounting plate
4	Bottom cover	8	Enclosure rails

Illustration 1.10 Installation of Bottom Cover

1.3.6 Mounting the Drive in the Enclosure

To install the mounting plate and drive in the enclosure, use the following steps. Refer to *Illustration 1.11*.

1. Remove the paper backing from both 6-hole gaskets, exposing the adhesive. Adhere 1 gasket around the vent opening on each side of the mounting plate.
2. Attach the mounting plate to the enclosure rails, making sure that the pem nuts face the back of the enclosure.
3. Loosely fasten 3 M10 screws (not supplied in kit) into the pem nuts at the lower end of the mounting plate. Make sure that the screws are secure since the base of the drive rests on these screws.
4. Slightly lean the top of the drive forward and set the cutouts in the base onto the 3 screws in the mounting plate.
5. Slowly push the top of the drive back against the mounting plate until the top 3 pem nuts line up with the holes in the drive. Secure the top of the drive using 3 M10 screws.
6. Torque all 6 M10 screws to 19 Nm (170 in-lb).

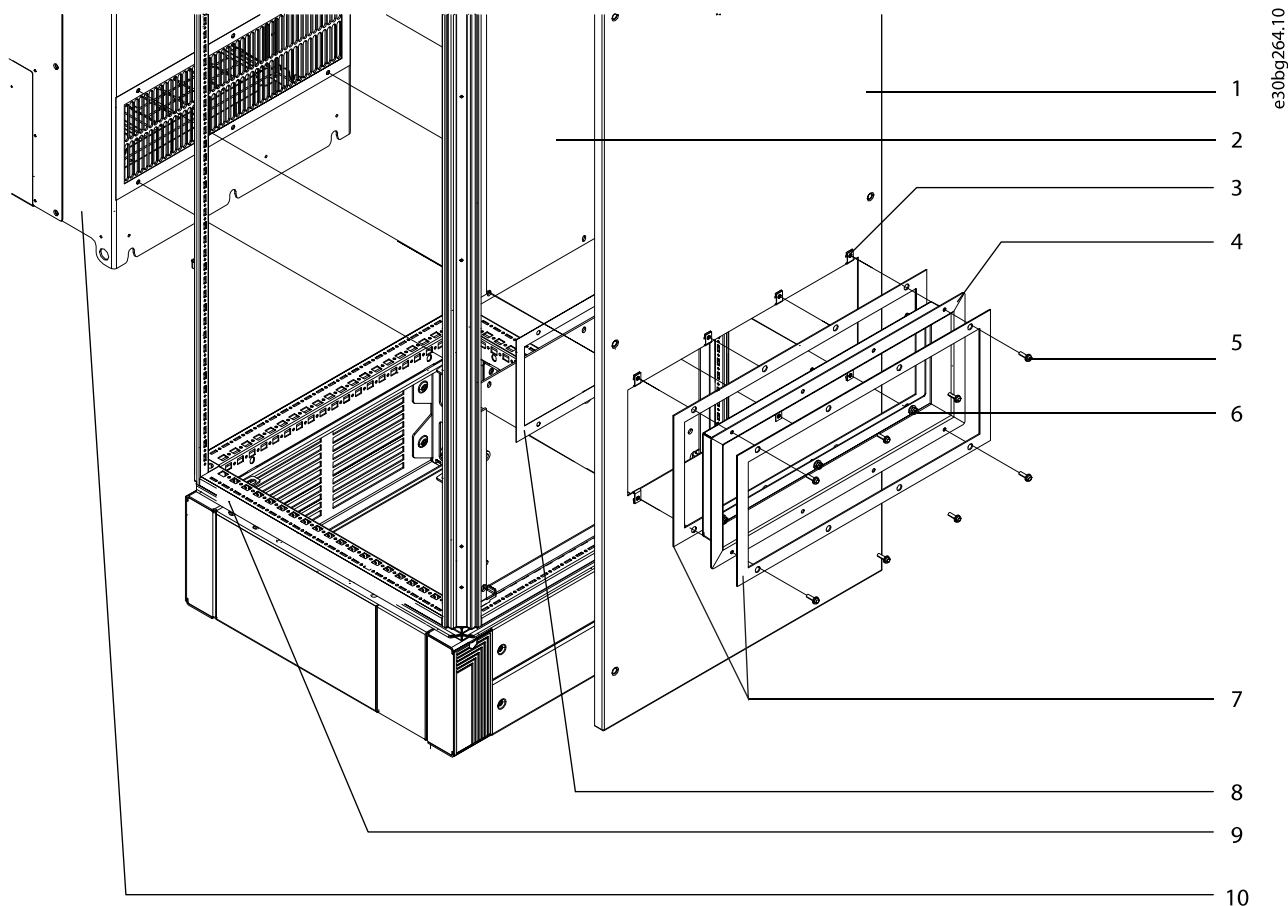

1	Backplate	6	M6x12 screw
2	Mounting plate	7	8-hole gaskets
3	M5 clip-on nut	8	6-hole gaskets
4	Back duct	9	Rittal enclosure
5	M5x18 screw	10	Drive

Illustration 1.11 Installation of the Drive, Mounting Plate, Backplate, and Back Duct

1.3.7 Attaching the Top Duct to the Enclosure Top Plate

After the drive is installed on the mounting plate, attach the top duct to the enclosure top plate using the following procedure. Refer to *Illustration 1.2*.

1. Extend the telescoping bottom duct upward until the upper flange of the duct is positioned against the underside of the enclosure top plate.
2. Secure the duct to the top plate with 6 M5 hex nuts (T25) from the kit. Torque fasteners to 2.3 Nm (20 in-lb).

1.3.8 Installing the Backplate and Back Duct

To attach the enclosure backplate and the back duct, use the following steps. Refer to *Illustration 1.11*.

1. Position the backplate on the back rails of the enclosure behind the mounting plate.
2. Secure the backplate to the rails using the existing fasteners.
3. Slide 8 M5 clip-on nuts over the screw holes around the duct opening in the backplate.
4. Remove the paper backing from both 8-hole gaskets, exposing the adhesive. Adhere 1 gasket to the back and 1 to the front of the back duct outer flange.
5. Position the back duct in the hole created for it in the mounting plate and backplate.
6. Fasten the inner flange of the back duct with 6 M6x12 screws (T30). Torque to 3.9 Nm (35 in-lb).
7. Fasten the outer flange of the duct with 8 M5x18 screws (T25). Torque fasteners to 2.3 Nm (20 in-lb).

Danfoss can accept no responsibility for possible errors in catalogues, brochures and other printed material. Danfoss reserves the right to alter its products without notice. This also applies to products already on order provided that such alterations can be made without consequential changes being necessary in specifications already agreed. All trademarks in this material are property of the respective companies. Danfoss and the Danfoss logotype are trademarks of Danfoss A/S. All rights reserved.

