

# Installation Instructions

## Control Card VLT<sup>®</sup> FC Series

These instructions describe the replacement of the control card in:

- VLT<sup>®</sup> HVAC Drive FC 102.
- VLT<sup>®</sup> Refrigeration Drive FC 103.
- VLT<sup>®</sup> AQUA Drive FC 202.
- VLT<sup>®</sup> AutomationDrive FC 301/FC 302.
- VLT<sup>®</sup> Lift Drive LD 302.

### Safety Instructions

Only Danfoss authorized, qualified personnel is allowed to repair this equipment.



#### **DISCHARGE TIME**

The frequency converter contains DC-link capacitors, which can remain charged even when the frequency converter is not powered. High voltage can be present even when the warning LED indicator lights are off. Failure to wait the specified time after power has been removed before performing service or repair work can result in death or serious injury.

- Stop the motor.
- Disconnect AC mains and remote DC-link power supplies, including battery back-ups, UPS, and DC-link connections to other frequency converters.
- Disconnect or lock PM motor.
- Wait for the capacitors to discharge fully. The minimum duration of waiting time is specified in *Table 1.1* to *Table 1.5*.
- Before performing any service or repair work, use an appropriate voltage measuring device to make sure that the capacitors are fully discharged.

Voltage [V]	Minimum waiting time (minutes)					
	4	7	15	20	30	40
200–240	1.1–3.7 kW (1.50–5 hp)	–	5.5–45 kW (7.5–60 hp)	–	–	–
380–480	1.1–7.5 kW (1.50–10 hp)	–	11–90 kW (15–121 hp)	–	–	315–1000 kW (450–1350 hp)
400	–	–	–	90–315 kW (121–450 hp)	–	–
500	–	–	–	110–355 kW (150–500 hp)	–	–
525	–	–	–	75–315 kW (100–450 hp)	–	–
525–600	1.1–7.5 kW (1.50–10 hp)	–	11–90 kW (15–121 hp)	–	–	–
690	–	–	–	90–315 kW (100–350 hp)	–	–
525–690	–	1.1–7.5 kW (1.50–10 hp)	11–90 kW (15–121 hp)	–	400–1400 kW (500–1550 hp) 450–1400 kW (600–1550 hp)	–

Table 1.1 Discharge Time, VLT® HVAC Drive FC 102

Voltage [V]	Minimum waiting time (minutes)				
	4	7	15	20	40
200–240	0.25–3.7 kW (0.34–5 hp)	–	5.5–37 kW (7.5–50 hp)	–	–
380–480	0.25–7.5 kW (0.34–10 hp)	–	11–75 kW (15–100 hp)	110–315 (150–450 hp)	355–450 (500–600 hp) 355–560 (500–750 hp)
525–600	0.75–7.5 kW (1.0–10 hp)	–	11–75 kW (15–100 hp)	–	–
525–690	–	1.5–7.5 kW (2–10 hp)	11–75 kW (15–100 hp)	55–400 (75–400 hp)	450–630 (600–750 hp) 450–800 (600–950 hp)

Table 1.2 Discharge Time, VLT® Refrigeration Drive FC 103

Voltage [V]	Minimum waiting time (minutes)					
	4	7	15	20	30	40
200–240	0.25–3.7 kW (0.34–5 hp)	–	5.5–45 kW (7.5–60 hp)	–	–	–
380–480	0.37–7.5 kW (0.5–10 hp)	–	11–90 kW (15–121 hp)	110–315 kW (150–450 hp)	–	315–1000 kW (450–1350 hp) 355–560 kW (500–750 hp)
525–600	0.75–7.5 kW (1–10 hp)	–	11–90 kW (15–121 hp)	–	400–1400 kW (400–1550 hp)	–
525–690	–	1.1–7.5 kW (1.5–10 hp)	11–90 kW (10–100 hp)	75–400 kW (75–400 hp)	–	450–800 kW (450–950 hp)

Table 1.3 Discharge Time, VLT® AQUA Drive FC 202

Voltage [V]	Minimum waiting time (minutes)					
	4	7	15	20	30	40
200–240	0.25–3.7 kW (0.34–5 hp)	–	5.5–37 kW (7.5–50 hp)	–	–	–
380–500	0.25–7.5 kW (0.34–10 hp)	–	11–75 kW (15–100 hp)	90–200 kW (150–350 hp)	250–500 kW (450–750 hp)	250–800 kW (450–1350 hp) 315–500 (500–750 hp)
400	–	–	–	90–315 kW (125–450 hp)	–	–
500	–	–	–	110–355 kW (150–450 hp)	–	–
525	–	–	–	55–315 kW (75–400 hp)	–	–
525–600	0.75–7.5 kW (1–10 hp)	–	11–75 kW (15–100 hp)	–	–	–
525–690	–	1.5–7.5 kW (2–10 hp)	11–75 kW (15–100 hp)	37–315 kW (50–450 hp)	355–1200 kW (450–1550 hp)	355–2000 kW (450–2050 hp) 355–710 kW (400–950 hp)
690	–	–	–	55–315 kW (75–400 hp)	–	–

Table 1.4 Discharge Time, VLT® AutomationDrive FC 301/FC 302

Voltage [V]	Minimum waiting time (minutes)	
	4	15
380–480	0.25–7.5 kW (0.34–10 hp)	11–75 kW (15–100 hp)

Table 1.5 Discharge Time, VLT® Lift Drive, LD 302

### Item Supplied

The following item is supplied:

- Control card

### Tools

Only 2 tools are required for replacing the control card.

- Torx 10 screwdriver
- Flat-head screwdriver

### Additional Items Required

- VLT® frequency converter

### Replacing the Control Card

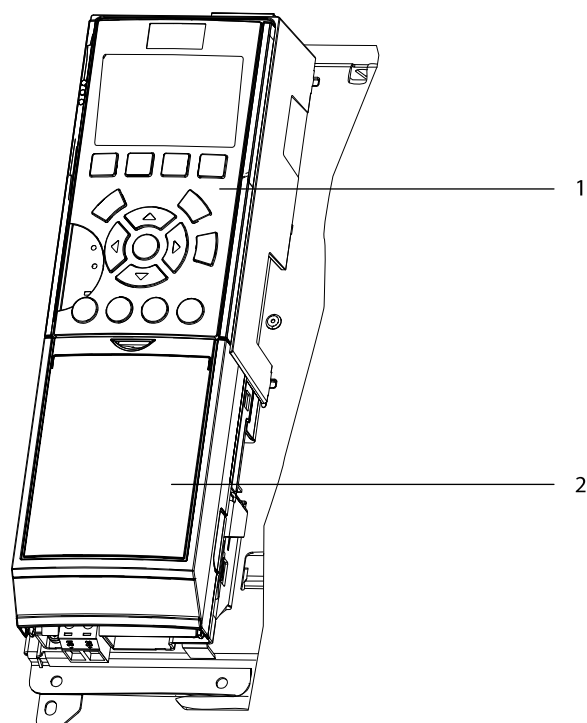

1	LCP
2	Blind cover

Illustration 1.1 LCP and Blind Cover

1. Remove the LCP and the blind cover.

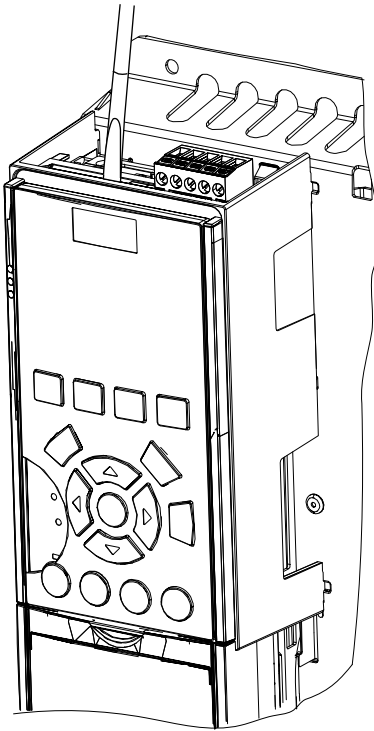

130BF718.10

2. Remove the LCP cradle.

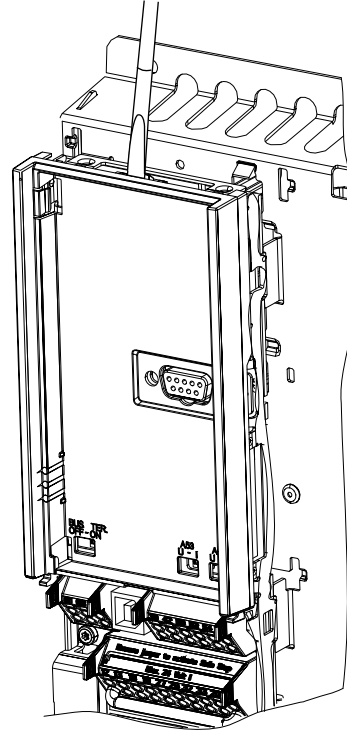

130BF720.10

Illustration 1.2 Removing LCP

Illustration 1.4 Removing LCP Cradle

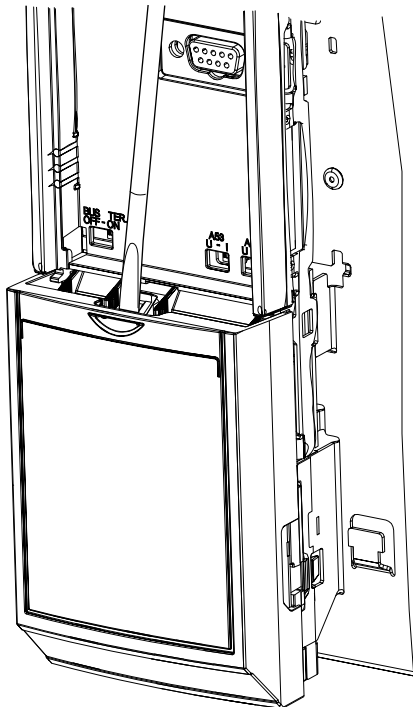

130BF719.10

Illustration 1.3 Removing Blind Cover

3. Remove all control cables from the metal bracket (spring-loaded).
4. Remove any A, B, or C options that may be installed.
5. Remove the I/O terminals.

6. Unscrew the 3 T10 screws and remove the cable shield.
7. Remove the plastic cover underneath the cable shield.

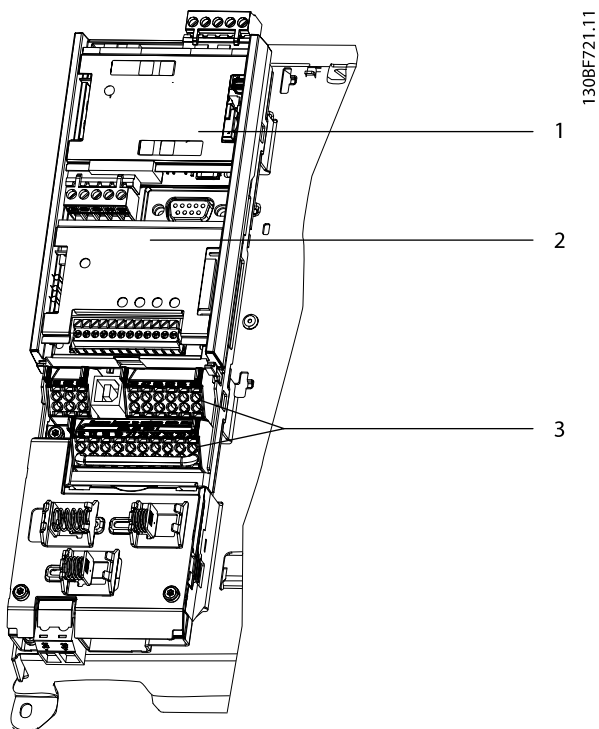

1	Location of A option
2	Location B option
3	I/O terminals

Illustration 1.5 Location of Options and I/O Terminals

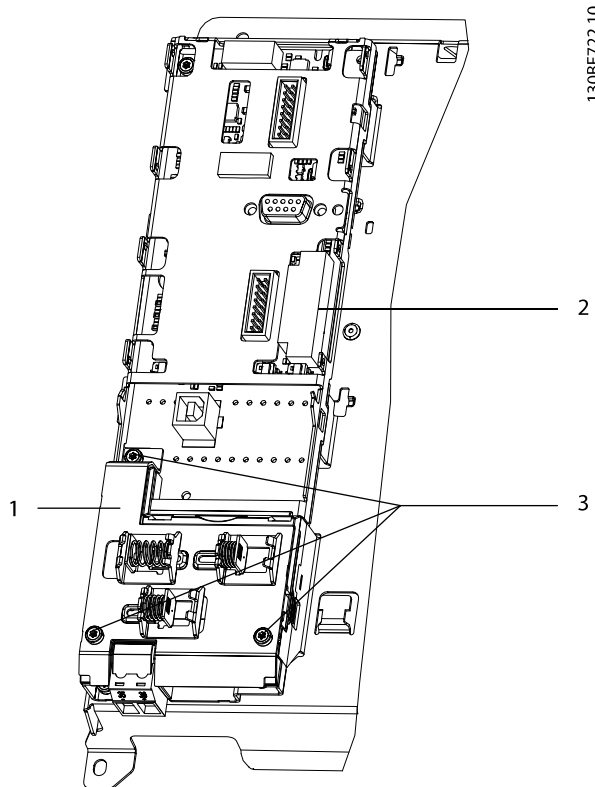

1	Cable shield
2	MCO ribbon cable
3	T10 screws

Illustration 1.6 Location of Cable Shield, Screws, and MCO Ribbon Cable

8. Unscrew the 2 T10 screws holding the control card EMC shield (4 screws if MCO is installed).
  - 8a If MCO is installed, remove the MCO ribbon cable.
9. Remove the control card EMC shield.

10. Unscrew the 3 T10 screws and remove them.
11. Gently remove the control card from the upper-right socket. Avoid overbending and contact with electronic components.

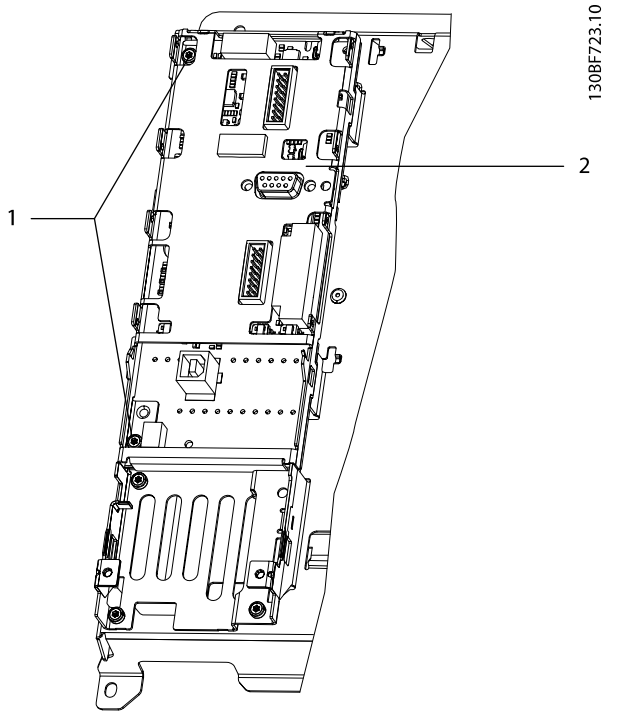

1	T10 screws
2	EMC shield

Illustration 1.7 Screws and EMC Shield

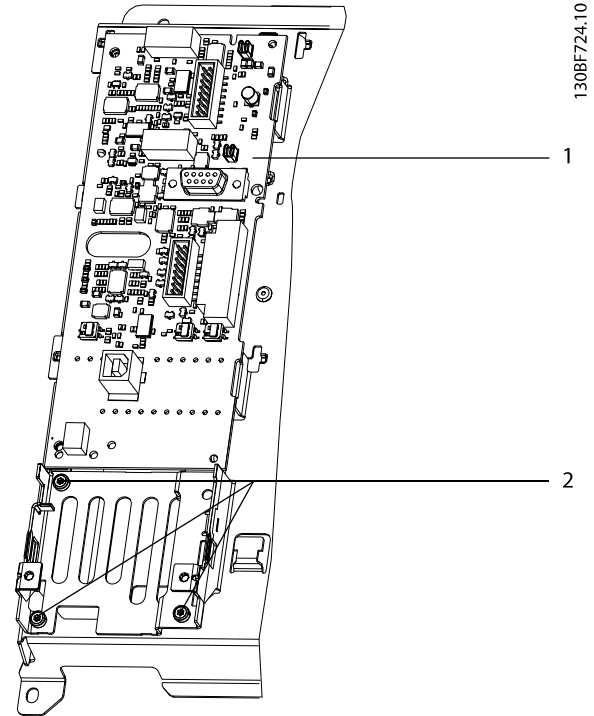

1	Control card
2	T10 screws

Illustration 1.8 Control Card and T10 Screws

Re-assemble the new control card in reverse order.

.....  
 Danfoss can accept no responsibility for possible errors in catalogues, brochures and other printed material. Danfoss reserves the right to alter its products without notice. This also applies to products already on order provided that such alterations can be made without subsequential changes being necessary in specifications already agreed. All trademarks in this material are property of the respective companies. Danfoss and the Danfoss logotype are trademarks of Danfoss A/S. All rights reserved.  
 .....

