

Panel weight ≈ 650 kg  
Schaltschrankgewicht

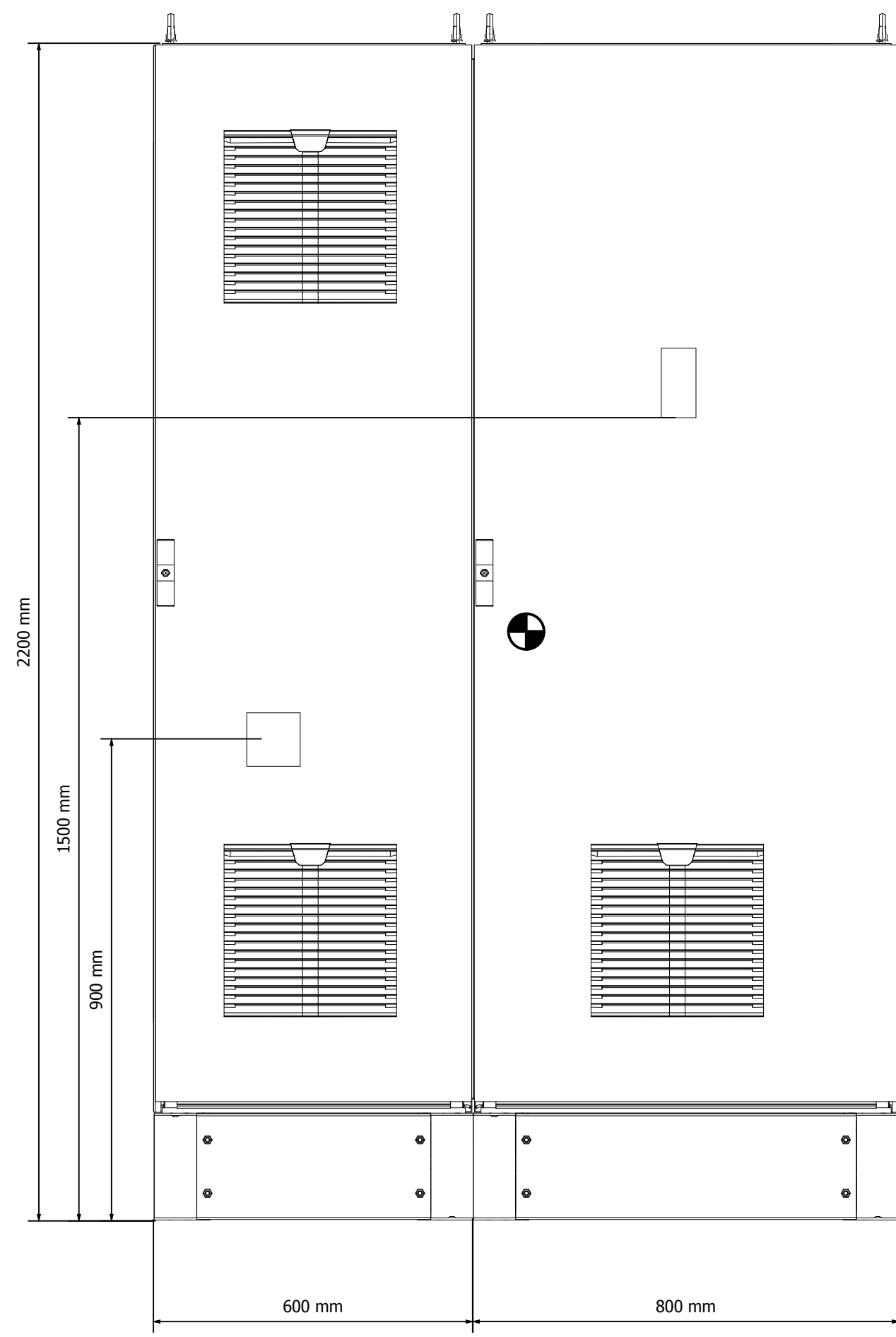

Front view  
Frontansicht

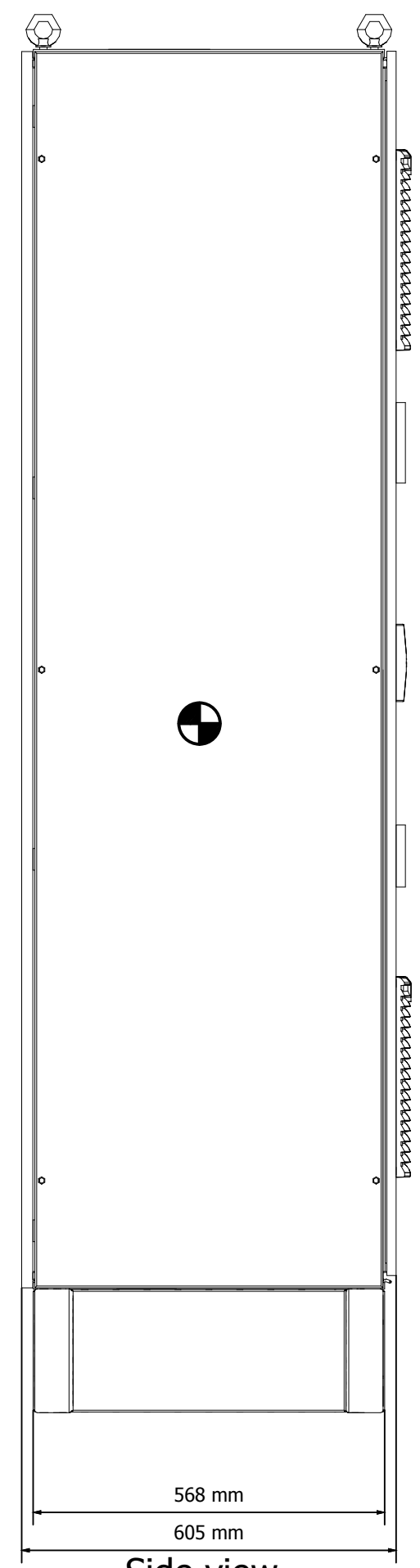

Side view  
Seitenansicht

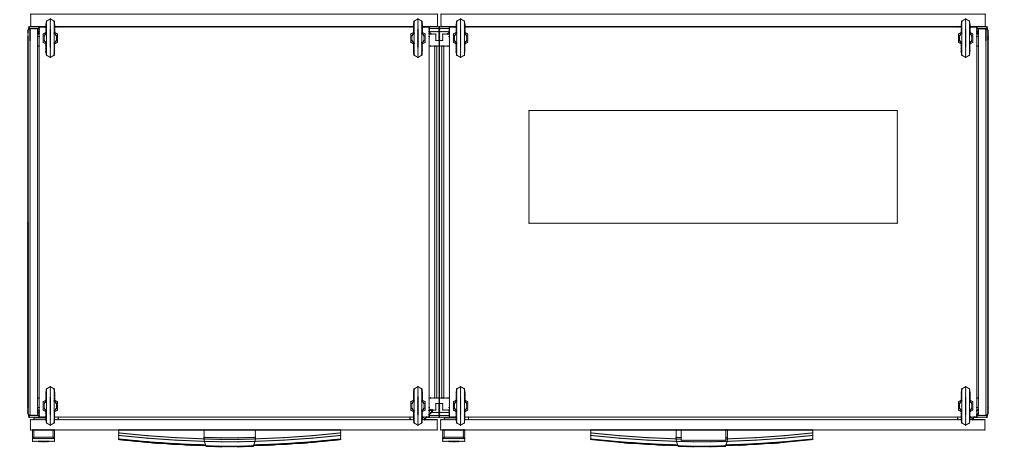

Top view  
Draufsicht

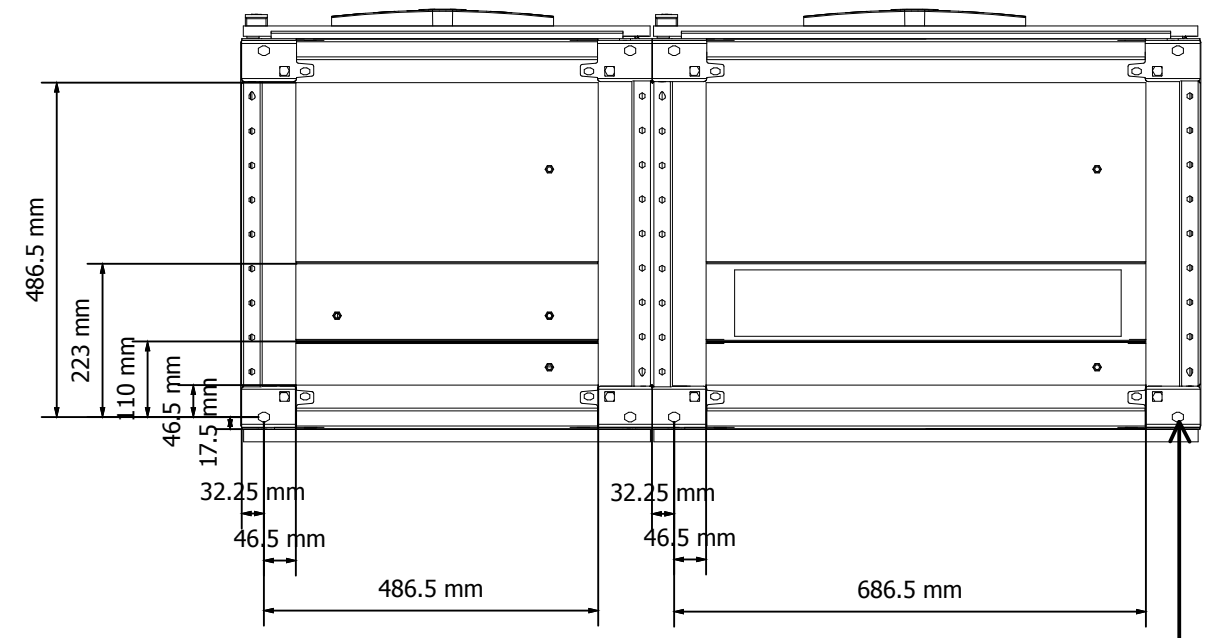

Bottom view  
Ansicht von unten

Detail A - 8 x 15 mm diameter

Note :  
Zu Beachten :

Centre of gravity location  
Schwerpunkt

1	Date	9/30/2013	Commission	315KW VFD Panel
	Ed.	----	Project description	Disconnect switch+dudt Filter
	Appr.	----		Trennschalter+dudt Filter
Modification	Date	Name	Contr.	----

Danfoss GmbH  
VLT Drives EMA, Carl-Legien Strasse 8  
63073 Offenbach, Germany



FILE-NAME:  
LOGOB300.jpg  
Size 300px x 116px

Page description  
Model view  
Modell-Ansicht

Project Number  
----  
SAP NO

= DOCUMENTATION  
+ LAYOUT  
Manufacturer no

Page  
2  
Page  
34