

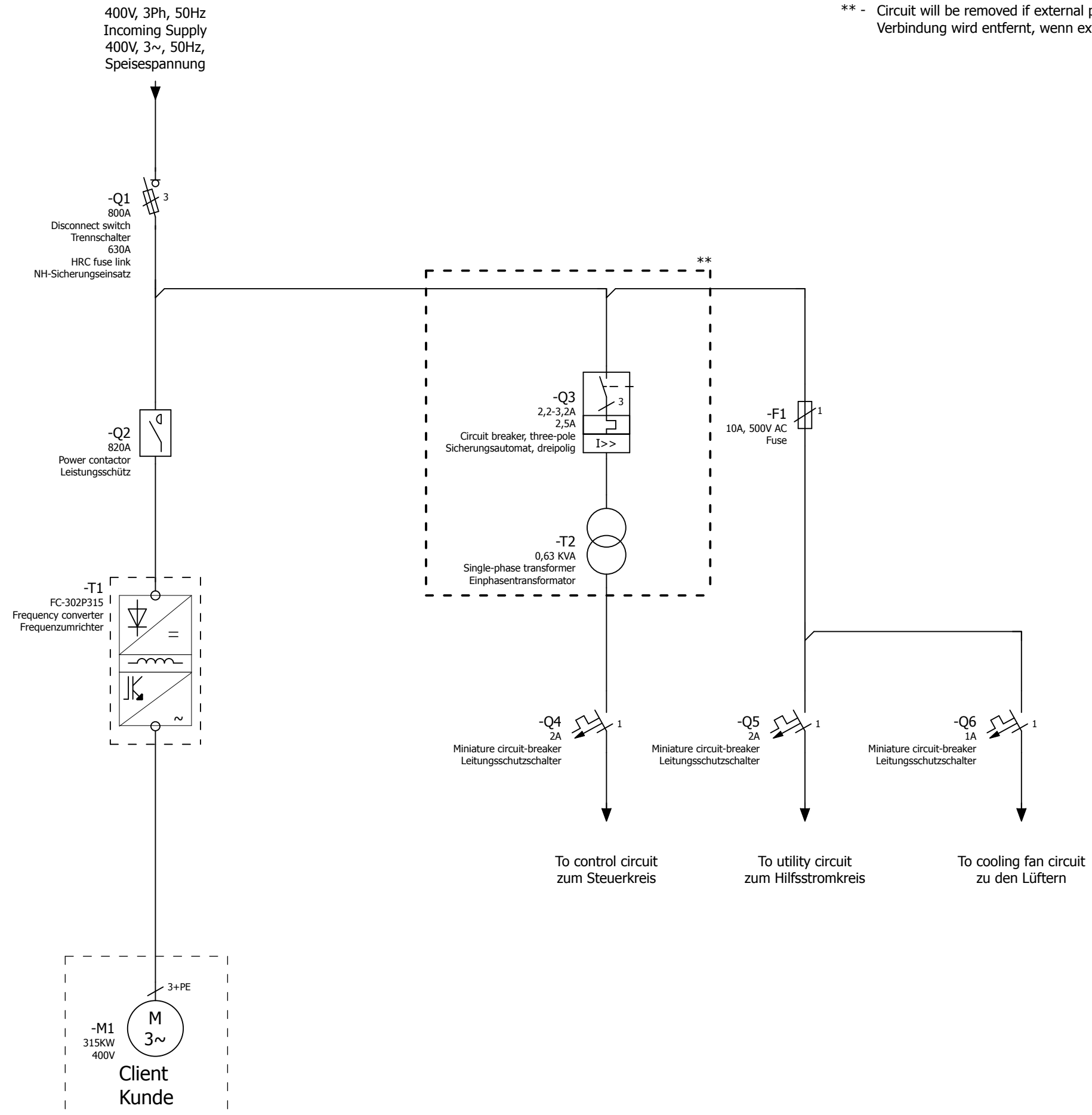

** - Circuit will be removed if external power supply considered
Verbindung wird entfernt, wenn externe Spannungsversorgung angelegt wird



=REPORT+CONNECTION LIST/3

Date		9/30/2013	Commission		Danfoss GmbH			FILE-NAME: LOGOB300.jpg Size 300px x 116px	Page description		Project Number		= FC302		Page
Ed.		----	Project description		VLT Drives EMA, Carl-Legien Strasse 8				Schematic single-line Schaltplan einpolig		-----		+ P315KW 230V		1
Appr.		----	Contactor+Fuse+Disconnect switch Schütz+Sicherung+Trennschalter		63073 Offenbach, Germany				SAP NO		Manufacturer no		Page	34	