

** - Circuit will be removed if external power supply considered
Verbindung wird entfernt, wenn externe Spannungsversorgung angelegt wird

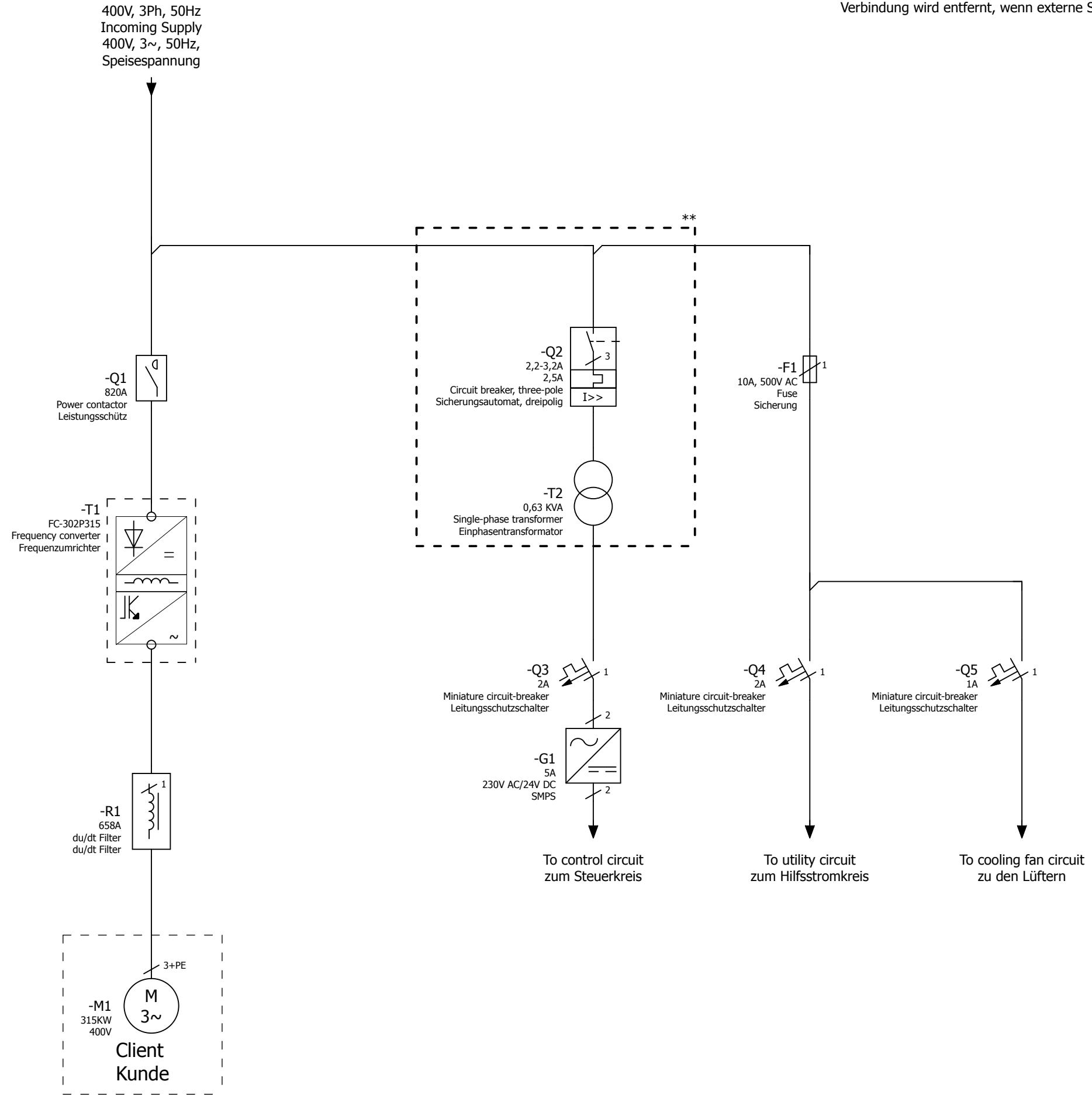

=REPORT+CONNECTION LIST/3

| | | | | | | | | | | | | |
|--------------|--|-----------|------------------------|--------|---------------------------------------|---|--|--|----------------|------|--------------|------|
| Date | | 9/30/2013 | Commission | | Danfoss GmbH |  | FILE-NAME: LOGOB300.jpg Size 300px x 116px | Page description Schematic single-line Schaltplan einpolig | Project Number | | = FC302 | Page |
| Ed. | | ---- | Project description | | VLT Drives EMA, Carl-Legien Strasse 8 | | | | SAP NO | | + P315KW 24V | |
| Appr. | | ---- | Contactor+du/dt Filter | | 63073 Offenbach, Germany | Manufacturer no | | | | Page | 35 | |
| Modification | | Date | Name | Contr. | ---- | Schütz+du/dt Filter | | | | | | |