

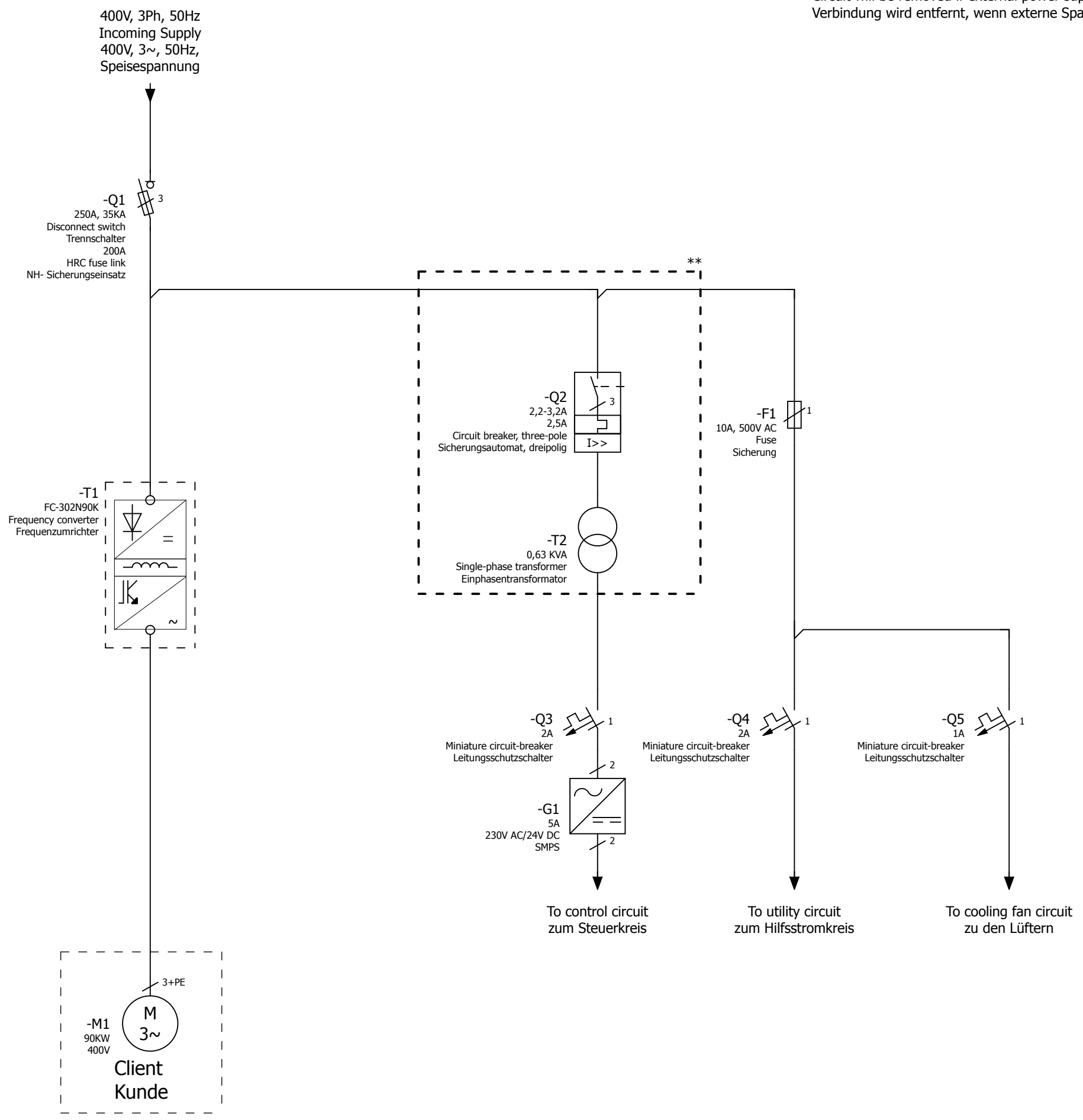

\*\* - Circuit will be removed if external power supply considered  
Verbindung wird entfernt, wenn externe Spannungsversorgung angelegt wird



=REPORT+CONNECTION LIST/4

Date		9/30/2013	Commission		Danfoss GmbH		FILE-NAME: LOGOB300.jpg Size 300px x 116px	Page description Schematic single-line Schaltplan einpolig	Project Number		= FC302	Page
Ed.		----	Project description		90KW VFD Panel				SAP NO		+ N90KW 24V	
Appr.		----	Disconnect switch+fuse		VLТ Drives EMA, Carl-Legien Strasse 8	Manufacturer no				Page	35	
Contr.		----	Trennschalter+Sicherung		63073 Offenbach, Germany							