

VACON®100
VACON®100 FLOW
VACON®100 HVAC
AC DRIVES

INSTALLATION MANUAL
WALL-MOUNTED DRIVES

VACON®

PREFACE

Document ID: DPD01711F

Date: 8.7.2015

ABOUT THIS MANUAL

This manual is copyright of Vacon Plc. All Rights Reserved.

TABLE OF CONTENTS

Preface

About this manual	3
1 Approvals	8
2 Safety	10
2.1 The safety symbols used in the manual	10
2.2 Warning	10
2.3 Caution	11
2.4 Grounding and earth fault protection	12
2.5 Electro-magnetic compatibility (EMC)	13
2.6 Using an RCD or an RCM device	13
3 Receiving the delivery	15
3.1 Package label	15
3.2 Type designation code	16
3.3 Contents of the delivery	16
3.4 Removing the packaging and lifting the AC drive	16
3.4.1 Weight of the AC drive	16
3.4.2 Lifting the frames MR8 and MR9	17
3.5 Accessories	18
3.5.1 Frame MR4	19
3.5.2 Frame MR5	19
3.5.3 Frame MR6	20
3.5.4 Frame MR7	21
3.5.5 Frame MR8	21
3.5.6 Frame MR9	22
3.6 "Product modified" label	22
3.7 Disposal	22
4 Mounting	23
4.1 General information about mounting	23
4.2 Dimensions for wall mounting	23
4.2.1 Wall mounting of MR4	23
4.2.2 Wall mounting of MR5	24
4.2.3 Wall mounting of MR6	25
4.2.4 Wall mounting of MR7	26
4.2.5 Wall mounting of MR8, IP21 and IP54	27
4.2.6 Wall mounting of MR8, IP00	28
4.2.7 Wall mounting of MR9, IP21 and IP54	29
4.2.8 Wall mounting of MR9, IP00	30

4.3	Dimensions for wall mounting, North America	31
4.3.1	Wall mounting of MR4, North America	31
4.3.2	Wall mounting of MR5, North America	32
4.3.3	Wall mounting of MR6, North America	33
4.3.4	Wall mounting of MR7, North America	34
4.3.5	Wall mounting of MR8, North America	35
4.3.6	Wall mounting of MR8, UL Open Type, North America	36
4.3.7	Wall mounting of MR9, North America	37
4.3.8	Wall mounting of MR9, UL Open Type, North America	38
4.4	Dimensions for flange mounting	38
4.4.1	Flange mounting of MR4	42
4.4.2	Flange mounting of MR5	43
4.4.3	Flange mounting of MR6	44
4.4.4	Flange mounting of MR7	45
4.4.5	Flange mounting of MR8	46
4.4.6	Flange mounting of MR9	47
4.5	Dimensions for flange mounting, North America	48
4.5.1	Flange mounting of MR4, North America	48
4.5.2	Flange mounting of MR5, North America	49
4.5.3	Flange mounting of MR6, North America	50
4.5.4	Flange mounting of MR7, North America	51
4.5.5	Flange mounting of MR8, North America	52
4.5.6	Flange mounting of MR9, North America	53
4.6	Cooling	54
5	Power cabling	57
5.1	Cable connections	57
5.2	UL standards on cabling	58
5.3	Cable dimensioning and selection	58
5.3.1	Cable and fuse sizes	58
5.3.2	Cable and fuse sizes, North America	63
5.4	Brake resistor cables	68
5.5	Preparing for the cable installation	69
5.6	Cable installation	69
5.6.1	Frames MR4 to MR7	69
5.6.2	Frames MR8 to MR9	76
5.7	Installation in a corner-grounded network	88
6	Control unit	89
6.1	Control unit components	89
6.2	Control unit cabling	90
6.2.1	Selection of the control cables	90
6.2.2	Control terminals and DIP switches	91
6.3	Fieldbus connection	95
6.3.1	Using fieldbus through an Ethernet cable	96
6.3.2	Using fieldbus through an RS485 cable	99
6.4	Installation of option boards	103
6.4.1	The installation procedure	104

6.5	Installation of a battery for the Real Time Clock (RTC)	105
6.6	Galvanic isolation barriers	105
7	Commissioning and additional instructions	107
7.1	Commissioning safety	107
7.2	Commissioning of the drive	107
7.3	Operation of the motor	108
7.3.1	Checks before starting the motor	108
7.4	Measuring the cable and motor insulation	108
7.5	Installation in a marine environment	109
7.6	Installation in an IT system	109
7.6.1	The EMC jumper in MR4, MR5 and MR6	109
7.6.2	The EMC jumper in MR7	112
7.6.3	The EMC jumper in MR8	114
7.6.4	The EMC jumper in MR9	115
7.7	Maintenance	116
8	Technical data, Vacon® 100	118
8.1	AC drive power ratings	118
8.1.1	Mains voltage 208-240 V	118
8.1.2	Mains voltage 380-500 V	120
8.1.3	Mains voltage 525-600 V	121
8.1.4	Mains voltage 525-690 V	122
8.1.5	Overload capability	122
8.1.6	Brake resistor ratings	123
8.2	Vacon® 100 - technical data	128
9	Technical data, Vacon® 100 FLOW	133
9.1	AC drive power ratings	133
9.1.1	Mains voltage 208-240 V	133
9.1.2	Mains voltage 380-500 V	135
9.1.3	Mains voltage 525-600 V	136
9.1.4	Mains voltage 525-690 V	137
9.1.5	Overload capability	137
9.2	Vacon® 100 FLOW - technical data	139
10	Technical data, Vacon® 100 HVAC	144
10.1	AC drive power ratings	144
10.1.1	Mains voltage 208-240 V	144
10.1.2	Mains voltage 380-500 V	145
10.1.3	Mains voltage 525-600 V	146
10.1.4	Overload capability	146
10.2	Vacon® 100 HVAC - technical data	148
11	Technical data on control connections	153
11.1	Technical data on control connections	153

1 APPROVALS

Here are the approvals that have been granted to this Vacon product.

1. EC Declaration of conformity
 - Find the EC Declaration of Conformity on the next page.
2. UL approval
 - cULus approval file number E171278.
3. RCM approval
 - RCM approval number E2204.



EC DECLARATION OF CONFORMITY

We

Manufacturer's name: Vacon Oyj
Manufacturer's address: P.O. Box 25
 Runsorintie 7
 FIN-65381 Vaasa
 Finland

hereby declare that the product

Product name: Vacon 100 AC drive
Model Designation: **Wall-Mounted Drives:**
 Vacon 0100 3L 0003 2...0310 2
 Vacon 0100 3L 0003 4...0310 4
 Vacon 0100 3L 0003 5...0310 5
 Vacon 0100 3L 0004 6...0208 6
 Vacon 0100 3L 0007 7...0208 7
IP00 Drives:
 Vacon 0100 3L 0140 2...0310 2
 Vacon 0100 3L 0140 5...1180 5
 Vacon 0100 3L 0080 6...0820 6
 Vacon 0100 3L 0080 7...0820 7
Enclosed Drives:
 Vacon 0100 3L 0140 5...0590 5
 Vacon 0100 3L 0080 7...0820 7

has been designed and manufactured in accordance with the following standards:

Safety: EN 61800-5-1: 2007
 EN 60204-1: 2009 (as relevant)
EMC: EN 61800-3: 2004 + A1: 2012
 EN 61000-3-12

and conforms to the relevant safety provisions of the Low Voltage Directive (2006/95/EC) and EMC Directive 2004/108/EC.

It is ensured through internal measures and quality control that the product conforms at all times to the requirements of the current Directive and the relevant standards.

In Vaasa, 31st of March, 2015

Vesa Laisi
 President

The year the CE marking was affixed: 2009



2 SAFETY

2.1 THE SAFETY SYMBOLS USED IN THE MANUAL

This manual contains warnings and cautions, which are identified with safety symbols. The warnings and cautions give important information on how to prevent injury and damage to the equipment or your system.

Read the warnings and cautions carefully and obey their instructions.

Table 1: The safety symbols

The safety symbol	Description
	WARNING!
	CAUTION!
	HOT SURFACE!

2.2 WARNING



WARNING!

Do not touch the components of the power unit when the drive is connected to mains. The components are live when the drive is connected to mains. A contact with this voltage is very dangerous.



WARNING!

Do not touch the motor cable terminals U, V, W, the brake resistor terminals or the DC terminals when the drive is connected to mains. These terminals are live when the drive is connected to mains, also when the motor does not operate.



WARNING!

Do not touch the control terminals. They can have a dangerous voltage also when the drive is disconnected from mains.

**WARNING!**

Before you do electrical work, make sure that there is no voltage in the components of the drive.

**WARNING!**

To do work on the terminal connections of the drive, disconnect the drive from mains and make sure that the motor has stopped. Wait 5 minutes before you open the cover of the drive. Then use a measuring device to make sure that there is no voltage. The terminal connections and the components of the drive are live 5 minutes after it is disconnected from mains and the motor has stopped.

**WARNING!**

Before you connect the drive to mains, make sure that the front cover and the cable cover of the drive are closed. The connections of the AC drive are live when the drive is connected to mains.

**WARNING!**

Disconnect the motor from the drive if an accidental start can be dangerous. When there is a power-up, a power break or a fault reset, the motor starts immediately if the start signal is active, unless the pulse control for Start/Stop logic is selected. If the parameters, the applications or the software change, the I/O functions (including the start inputs) can change.

**WARNING!**

Wear protective gloves when you do mounting, cabling or maintenance operations. There can be sharp edges in the AC drive that can cause cuts.

2.3 CAUTION**CAUTION!**

Do not move the AC drive. Use a fixed installation to prevent damage to the drive.

**CAUTION!**

Do not make measurements when the AC drive is connected to mains. It can cause damage to the drive.

**CAUTION!**

Make sure that there is reinforced protective ground connection. It is mandatory, because the touch current of the AC drives is more than 3.5 mA AC (refer to EN 61800-5-1). See chapter 2.4 *Grounding and earth fault protection*.

**CAUTION!**

Do not use spare parts that are not from the manufacturer. Using other spare parts can cause damage to the drive.

**CAUTION!**

Do not touch the components on the circuit boards. Static voltage can cause damage to these components.

**CAUTION!**

Make sure that the EMC level of the AC drive is correct for your mains. See chapter 7.6 *Installation in an IT system*. An incorrect EMC level can cause damage to the drive.

**CAUTION!**

Prevent radio interference. The AC drive can cause radio interference in a domestic environment.

**NOTE!**

If you activate the autoreset function, the motor starts automatically after an automatic fault reset. See the Application Manual.

**NOTE!**

If you use the AC drive as a part of a machine, the machine manufacturer must supply a mains disconnection device (refer to EN 60204-1).

2.4 GROUNDING AND EARTH FAULT PROTECTION

**CAUTION!**

The AC drive must always be grounded with a grounding conductor that is connected to the grounding terminal that is identified with the symbol \oplus . Not using a grounding conductor can cause damage to the drive.

The touch current of the drive is more than 3.5 mA AC. The standard EN 61800-5-1 tells that 1 or more of these conditions for the protective circuit must be true.

The connection must be fixed.

- a) The protective grounding conductor must have a cross-sectional area of minimum 10 mm² Cu or 16 mm² Al. OR
- b) There must be an automatic disconnection of the mains, if the protective grounding conductor breaks. See chapter 5 *Power cabling*. OR
- c) There must be a terminal for a second protective grounding conductor in the same cross-sectional area as the first protective grounding conductor.

Table 2: Protective grounding conductor cross-section

Cross-sectional area of the phase conductors (S) [mm ²]	The minimum cross-sectional area of the protective grounding conductor in question [mm ²]
$S \leq 16$	S
$16 < S \leq 35$	16
$35 < S$	S/2

The values of the table are valid only if the protective grounding conductor is made of the same metal as the phase conductors. If this is not so, the cross-sectional area of the protective grounding conductor must be determined in a manner that produces a conductance equivalent to that which results from the application of this table.

The cross-sectional area of each protective grounding conductor that is not a part of the mains cable or the cable enclosure, must be a minimum of:

- 2.5 mm² if there is mechanical protection, and
- 4 mm² if there is not mechanical protection. If you have cord-connected equipment, make sure that the protective grounding conductor in the cord is the last conductor to be interrupted, if the strain-relief mechanism breaks.

Obey the local regulations on the minimum size of the protective grounding conductor.

**NOTE!**

Because there are high capacitive currents in the AC drive, it is possible that the fault current protective switches do not operate correctly.

**CAUTION!**

Do not do voltage withstand tests on the AC drive. The manufacturer has already done the tests. Doing voltage withstand tests can cause damage to the drive.

2.5 ELECTRO-MAGNETIC COMPATIBILITY (EMC)

The drive must obey the standard IEC 61000-3-12. To obey it, the short-circuit power S_{sc} must be a minimum of 120 R_{scE} at the interface point between your mains and the public mains. Make sure that you connect the drive and the motor to mains with a short-circuit power S_{sc} that is a minimum of 120 R_{scE} . If necessary, contact your mains operator.

2.6 USING AN RCD OR AN RCM DEVICE

The drive can cause a current in the protective grounding conductor. You can use a residual current-operated protective (RCD) device, or a residual current-operated monitoring (RCM) device to give protection against a direct or an indirect contact. Use a type B RCD or RCM device on the mains side of the drive.

NOTE! You can download the English and French product manuals with applicable safety, warning and caution information from www.vacon.com/downloads.

REMARQUE Vous pouvez télécharger les versions anglaise et française des manuels produit contenant l'ensemble des informations de sécurité, avertissements et mises en garde applicables sur le site www.vacon.com/downloads.

3 RECEIVING THE DELIVERY

Before a Vacon® AC drive is sent to the customer, the manufacturer makes many tests on the drive. However, after you remove the packaging, examine the drive for transport damages.

If the drive was damaged during the shipping, speak to the cargo insurance company or the carrier.

To make sure that the contents of the delivery is correct and complete, compare the type designation of the product to the type designation code. See Chapter 3.2 *Type designation code*.

3.1 PACKAGE LABEL



Fig. 1: The package label of Vacon AC drives

- | | |
|------------------------------|-------------------------------------|
| A. The batch ID | F. The nominal output current |
| B. The order number of Vacon | G. The IP class |
| C. The type designation code | H. The application code |
| D. The serial number | I. The order number of the customer |
| E. The mains voltage | |

3.2 TYPE DESIGNATION CODE

The type designation code of Vacon is made of standard codes and optional codes. Each part of the type designation code agrees to the data in your order. The code can have this format, for example:

VACON0100-3L-0061-5+IP54
VACON0100-3L-0061-5-FLOW

Table 3: The description of the parts in the type designation code

Code	Description
VACON	This part is same for all the products.
0100	The product range: 0100 = Vacon 100
3L	Input/Function: 3L = A 3-phase input
0061	The drive rating in amperes. For example, 0061 = 61 A
5	The mains voltage: 2 = 208-240 V 5 = 380-500 V 6 = 525-600 V 7 = 525-690 V
FLOW	The Vacon 100 FLOW AC drive
+IP54	The optional codes. There are many options, for example +IP54 (an AC drive with the IP protection class IP54)

3.3 CONTENTS OF THE DELIVERY

The contents of the delivery, MR4-MR9

- The wall-mounted drive with an integrated control unit
- An accessories bag
- Quick Guide, Safety Instructions, and the manuals for the options that you ordered
- Installation Manual and Application Manual if you ordered them

3.4 REMOVING THE PACKAGING AND LIFTING THE AC DRIVE

3.4.1 WEIGHT OF THE AC DRIVE

The weights of AC drives of different frames are very different. It can be necessary for you to use a lifting device to move the drive from its package.

Table 4: The weights of the different frames

Frame	Weight, IP21/IP54 [kg]	Weight, IP00 [kg]	Weight, UL Type 1 / Type 12 [lb.]	Weight, UL Open Type [lb.]
MR4	6.0		13.2	
MR5	10.0		22.0	
MR6	20.0		44.1	
MR7	37.5		82.7	
MR8	66.0	62.0	145.5	136.7
MR9	119.5	103.5	263.5	228.2

3.4.2 LIFTING THE FRAMES MR8 AND MR9

- 1 Remove the drive from the pallet where it was bolted to.
- 2 Use a lifting device that is sufficiently strong for the weight of the drive.
- 3 Put the lifting hooks symmetrically in a minimum of 2 holes.

- 4 The maximum lifting angle is 45 degrees.

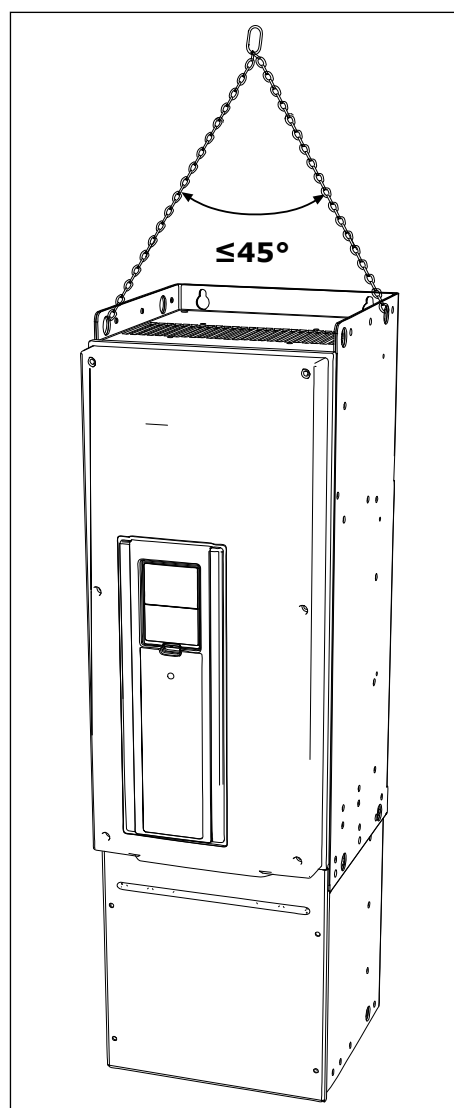

3.5 ACCESSORIES

After you open the package and lift the drive out, make sure that you received all the accessories. The content of the accessories bag is different for the different frames and protection classes.

3.5.1 FRAME MR4

Table 5: The content of the accessories bag

Item	Quantity	Description
M4x16 screw	11	Screws for the grounding clamps for cable shield (6), the grounding clamps for control cable (3), and the grounding clamps for grounding conductor (2)
M4x8 screw	1	Screw for the optional grounding
M5x12 screw	1	Screw for the external grounding of the drive
Grounding clamp for control cable	3	Control cable grounding
Grounding clamp for cable shield, size M25	3	Clamping the power cables
Grounding clamp for grounding conductor	2	Power cable grounding
"Product modified" label	1	Data about changes
IP21: Cable grommet	3	Sealing for the cables
IP54: Cable grommet	6	Sealing for the cables

3.5.2 FRAME MR5

Table 6: The content of the accessories bag

Item	Quantity	Description
M4x16 screw	13	Screws for the grounding clamps for cable shield (6), the grounding clamps for control cable (3), and the grounding clamps for grounding conductor (4)
M4x8 screw	1	Screw for the optional grounding
M5x12 screw	1	Screw for the external grounding of the drive
Grounding clamp for control cable	3	Control cable grounding
Grounding clamp for cable shield, size M25	1	Clamping the brake cable
Grounding clamp for cable shield, size M32	2	Clamping the power cables
Grounding clamp for grounding conductor	2	Power cable grounding
"Product modified" label	1	Data about changes
IP21: Cable grommet, hole diameter 25.3 mm	1	Sealing for the cables
IP54: Cable grommet, hole diameter 25.3 mm	4	Sealing for the cables
Cable grommet, hole diameter 33.0 mm	2	Sealing for the cables

3.5.3 FRAME MR6

Table 7: The content of the accessories bag

Item	Quantity	Description
M4x20 screw	10	Screws for the grounding clamps for cable shield (6), and the grounding clamps for grounding conductor (4)
M4x16 screw	3	Screws for the control cable clamps
M4x8 screw	1	Screw for the optional grounding
M5x12 screw	1	Screw for the external grounding of the drive
Grounding clamp for control cable	3	Control cable grounding
Grounding clamp for cable shield, size M32	1	Clamping the brake resistor cable
Grounding clamp for cable shield, size M40	2	Clamping the power cables
Grounding clamp for grounding conductor	2	Power cable grounding
"Product modified" label	1	Data about changes
Cable grommet, hole diameter 33.0 mm	1	Sealing for the cables
Cable grommet, hole diameter 40.3 mm	2	Sealing for the cables
IP54: Cable grommet, hole diameter 25.3 mm	3	Sealing for the cables



NOTE!

The Vacon® 100 FLOW and HVAC software do not have the dynamic braking or the brake resistor functions.

3.5.4 FRAME MR7

Table 8: The content of the accessories bag

Item	Quantity	Description
M6x30 slotted nut	6	Nuts for the grounding clamps for cable shield
M4x16 screw	3	Screws for the grounding clamps for control cable
M6x12 screw	1	Screw for the external grounding of the drive
Grounding clamp for control cable	3	Control cable grounding
Grounding clamp for cable shield, size M25	3	Clamping the power cables
Grounding clamp for grounding conductor	2	Power cable grounding
'Product modified' label	1	Data about changes
IP21: Cable grommet	3	Sealing for the cables
IP54: Cable grommet	3	Sealing for the cables

3.5.5 FRAME MR8

Table 9: The content of the accessories bag

Item	Quantity	Description
M4x16 screw	3	Screws for the grounding clamps for control cable
Grounding clamp for control cable	3	Control cable grounding
Grounding clamp for cable shield KP40	3	Clamping the power cables
Cable insulator	11	To prevent contact between cables
Cable grommet, hole diameter 25.3 mm	4	Sealing for the cables
IP00: Touch protection shield	1	To prevent contact with live parts
IP00: M4x8 screw	2	To attach the touch protection shield

3.5.6 FRAME MR9

Table 10: The content of the accessories bag

Item	Quantity	Description
M4x16 screw	3	Screws for the grounding clamps for control cable
Grounding clamp for control cable	3	Control cable grounding
Grounding clamp for cable shield KP40	5	Clamping the power cables
Cable insulator	10	To prevent contact between cables
Cable grommet, hole diameter 25.3 mm	4	Sealing for the cables
IP00: Touch protection shield	1	To prevent contact with live parts
IP00: M4x8 screw	2	To attach the touch protection shield

3.6 "PRODUCT MODIFIED" LABEL

In the accessories bag, there is also a "product modified" label. The function of the label is to tell the service personnel about the changes that are made in the AC drive. Attach the label on the side of the AC drive to know where to find it. If you make changes in the AC drive, write the change on the label.

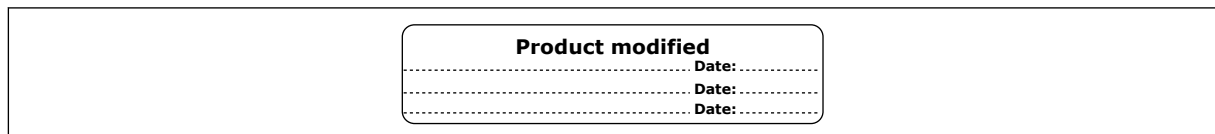

3.7 DISPOSAL

	<p>When the drive is at the end of its operation life, do not discard it as a part of municipal waste. You can recycle the primary components of the drive. You must disassemble some components before you can remove the different materials. Recycle the electrical and electronic components as waste.</p> <p>To make sure that the waste is recycled correctly, send the waste to a recycling centre. You can also send the waste back to the manufacturer.</p> <p>Obey the local and other applicable regulations.</p>
--	--

4 MOUNTING

4.1 GENERAL INFORMATION ABOUT MOUNTING

Install the AC drive in a vertical position on the wall. If you install the drive in a horizontal position, it is possible that some functions with the nominal values that are found in chapter 8 *Technical data, Vacon® 100* or 9 *Technical data, Vacon® 100 FLOW* are not available.

Install the AC drive with the screws and other components that you received in the delivery.

4.2 DIMENSIONS FOR WALL MOUNTING

4.2.1 WALL MOUNTING OF MR4

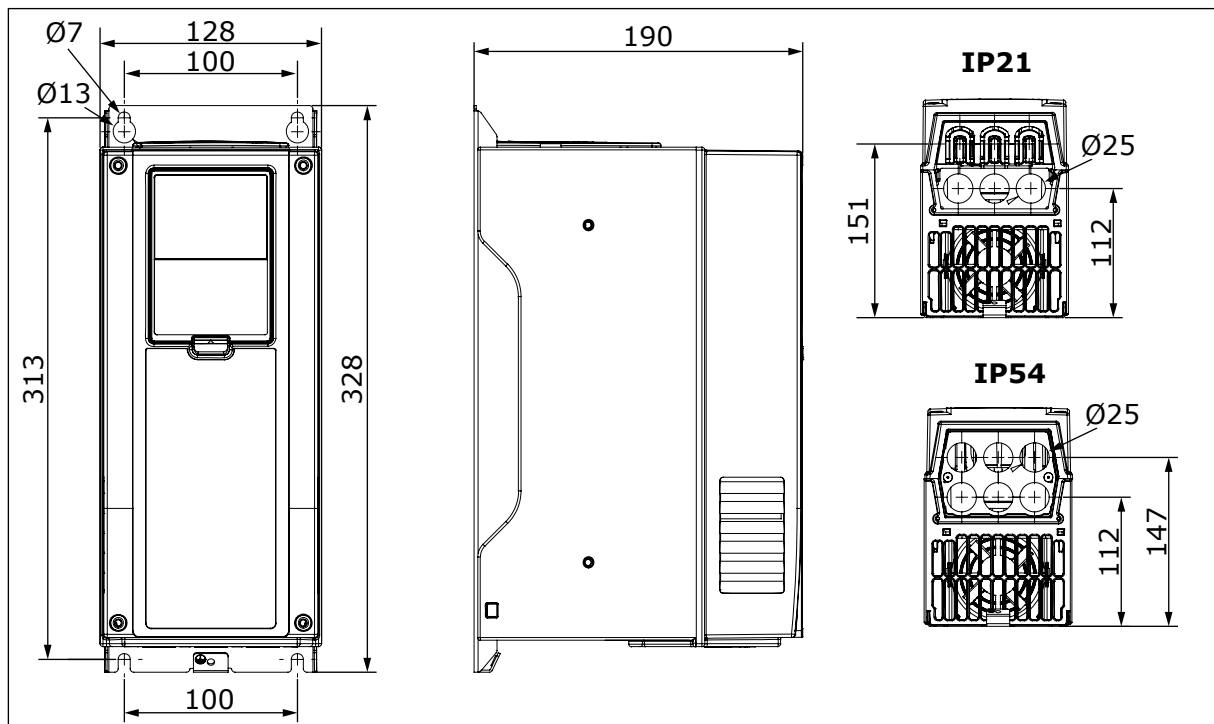

Fig. 2: The dimensions of the AC drive, MR4 [mm]

4.2.2 WALL MOUNTING OF MR5

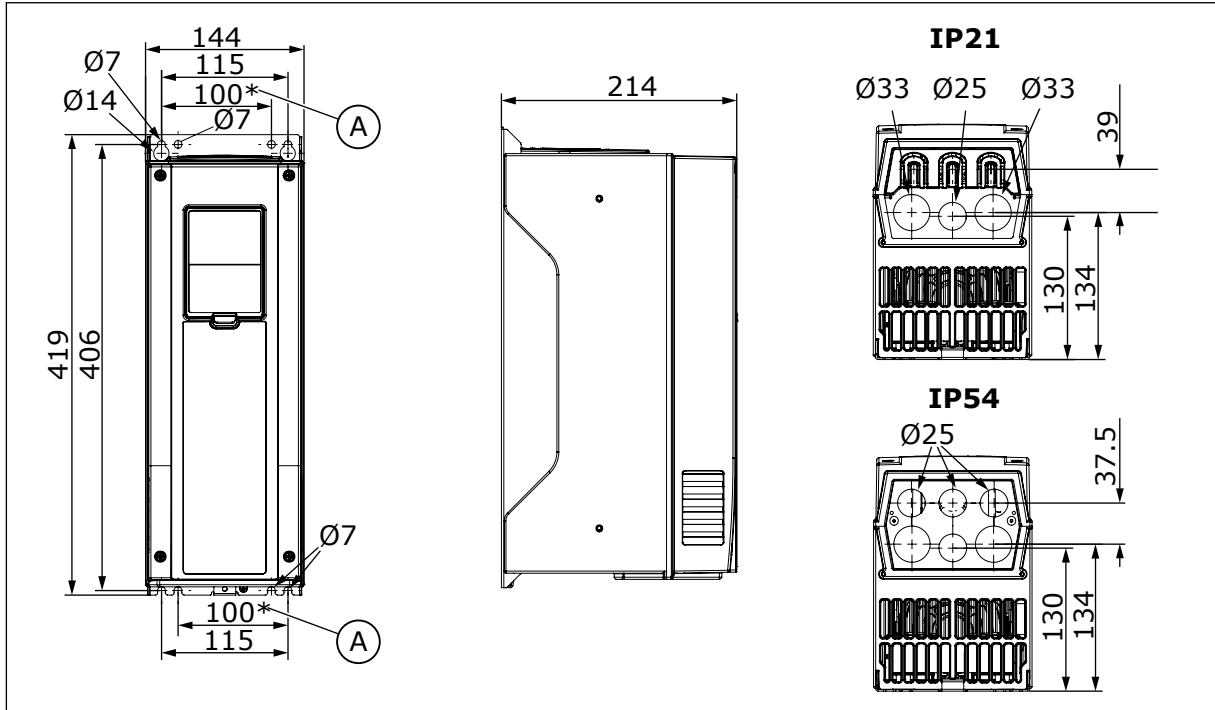

Fig. 3: The dimensions of the AC drive, MR5 [mm]

- A. Use these mounting holes when you replace your Vacon® NX AC drive with a Vacon® 100, Vacon® 100 FLOW or Vacon® 100 HVAC AC drive.

4.2.3 WALL MOUNTING OF MR6

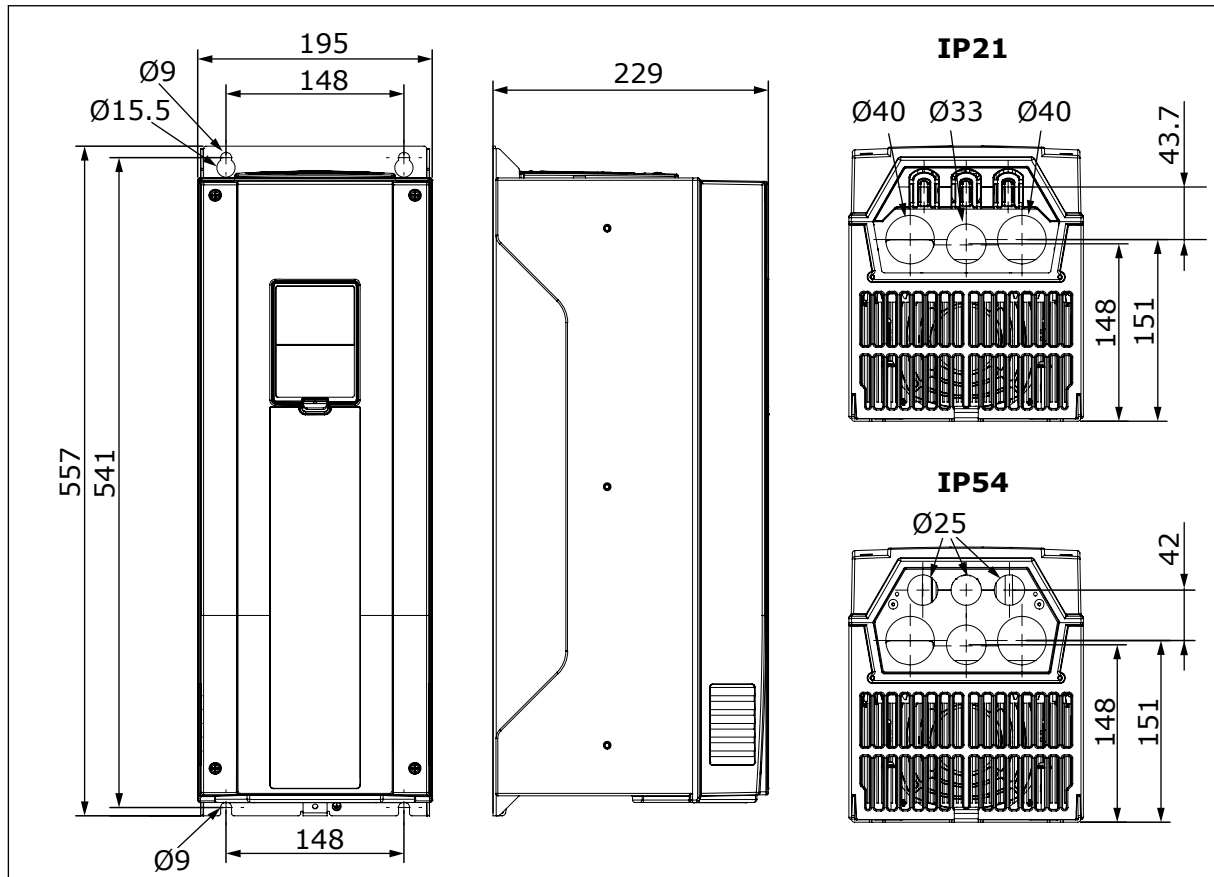

Fig. 4: The dimensions of the AC drive, MR6 [mm]

4.2.4 WALL MOUNTING OF MR7

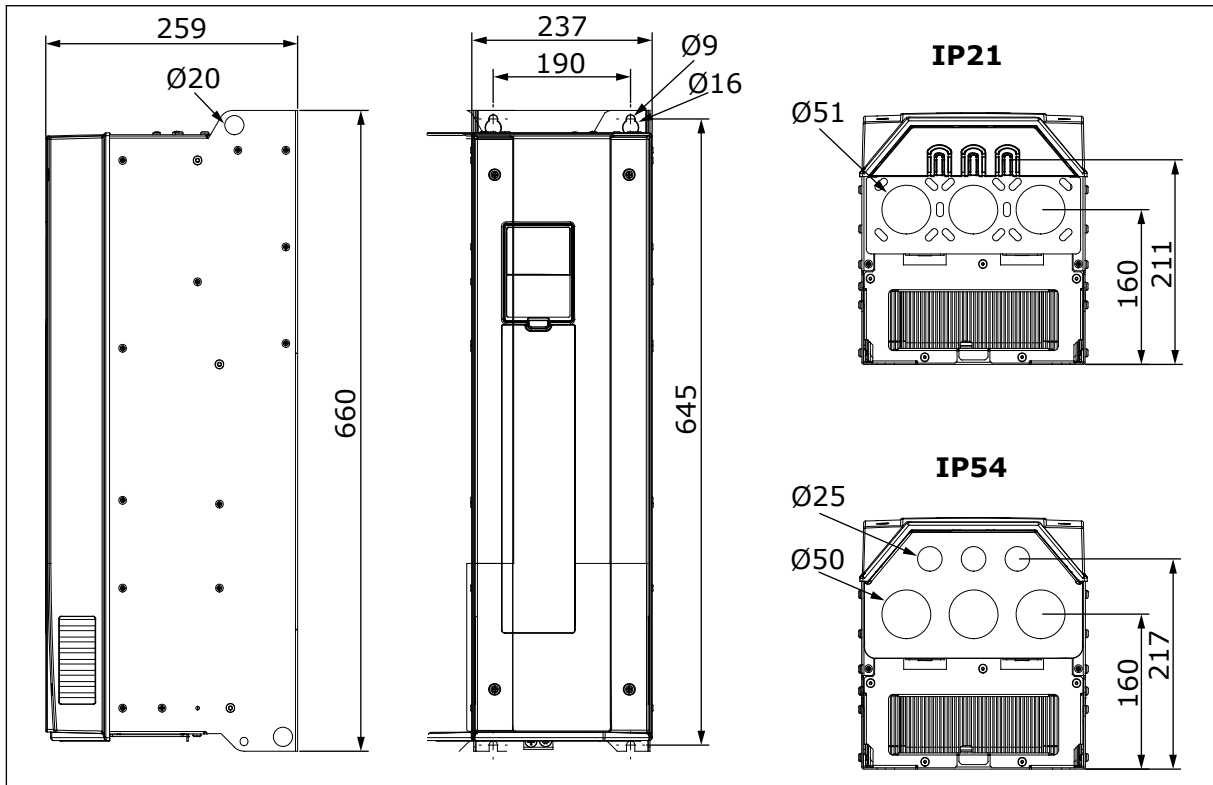

Fig. 5: The dimensions of the AC drive, MR7 [mm]

4.2.5 WALL MOUNTING OF MR8, IP21 AND IP54

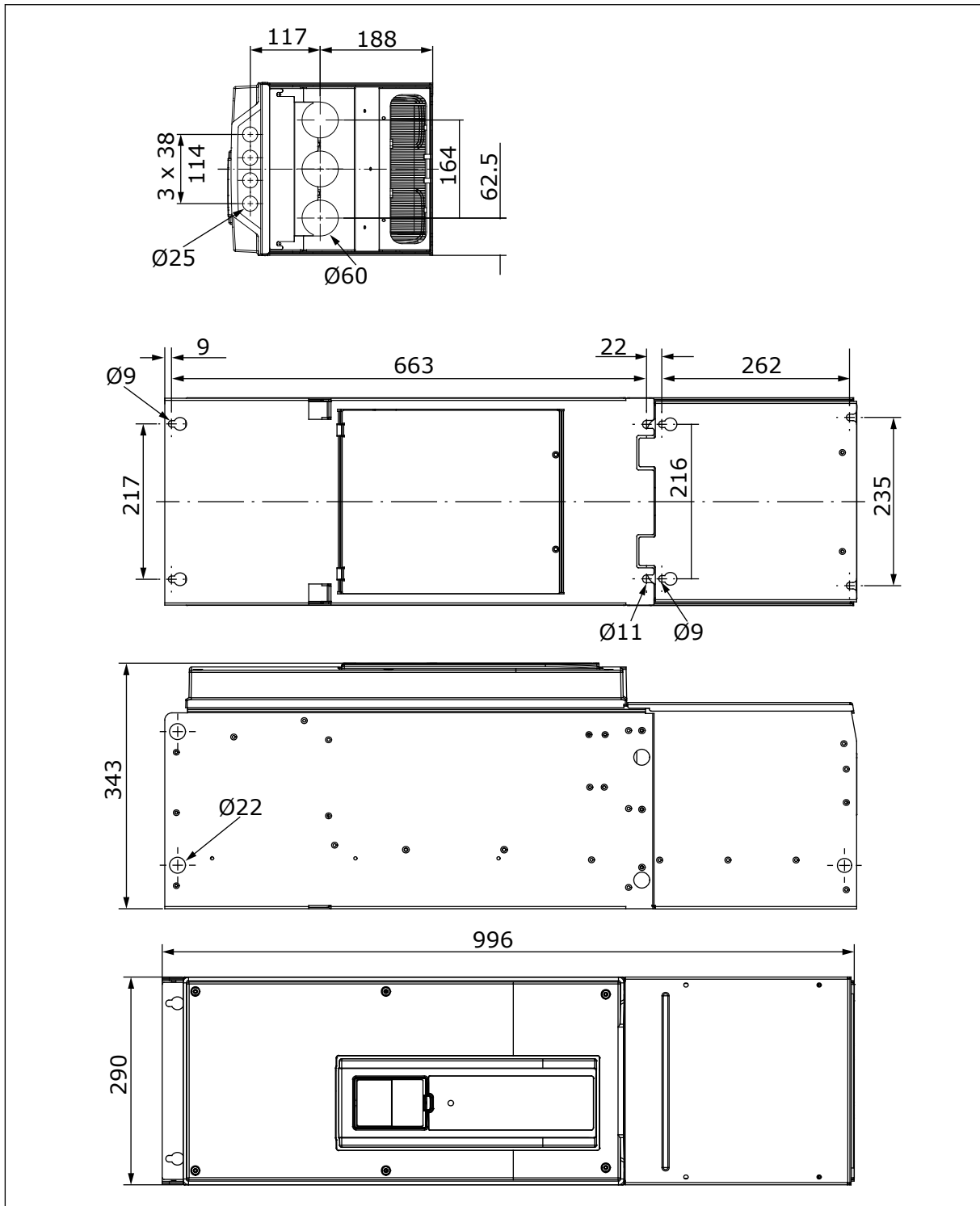

Fig. 6: The dimensions of the AC drive, MR8, IP21 and IP54 [mm]

4.2.6 WALL MOUNTING OF MR8, IP00

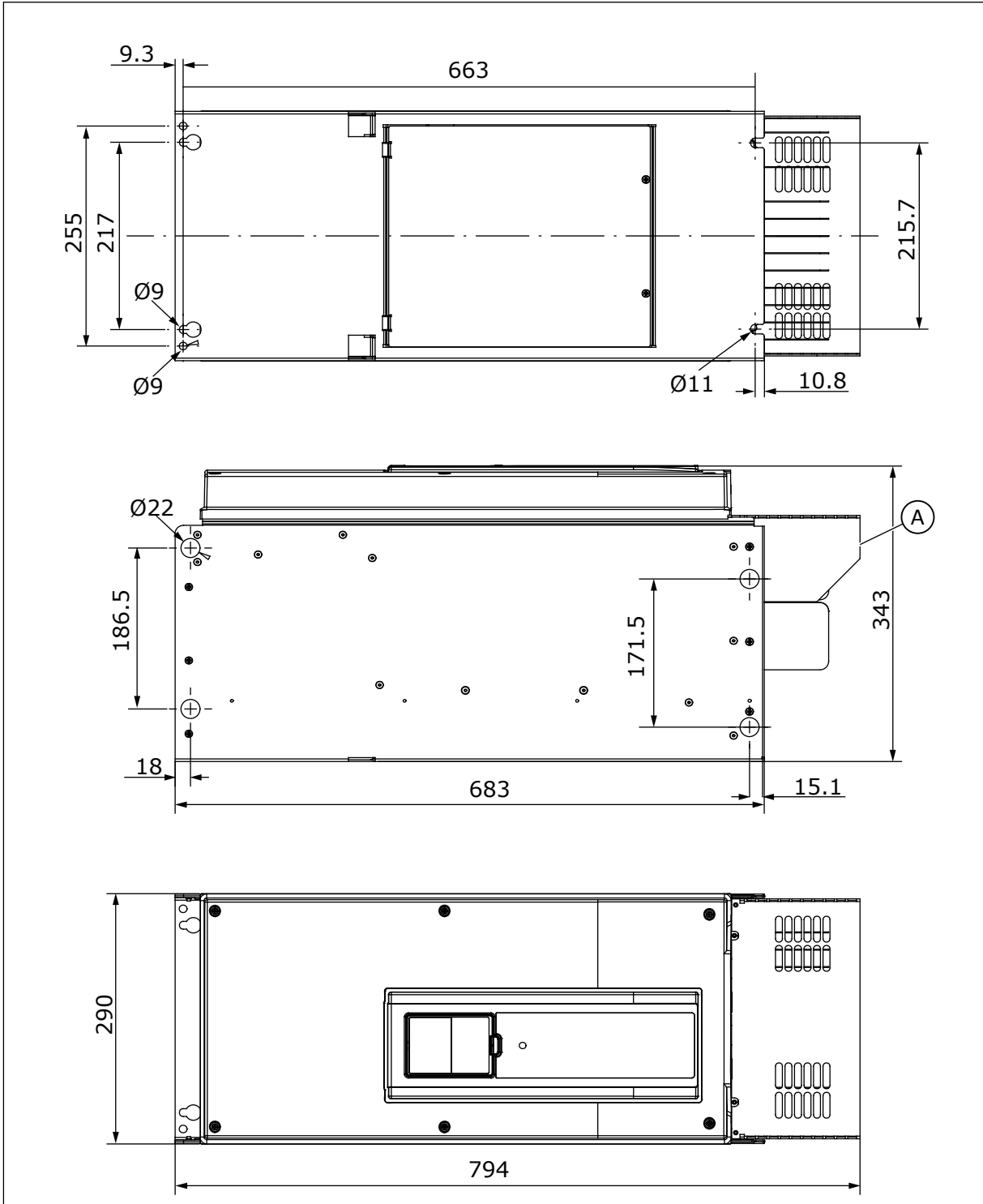

Fig. 7: The dimensions of the AC drive, MR8, IP00 [mm]

- A. An optional main connector cover for the cabinet installation

4.2.7 WALL MOUNTING OF MR9, IP21 AND IP54

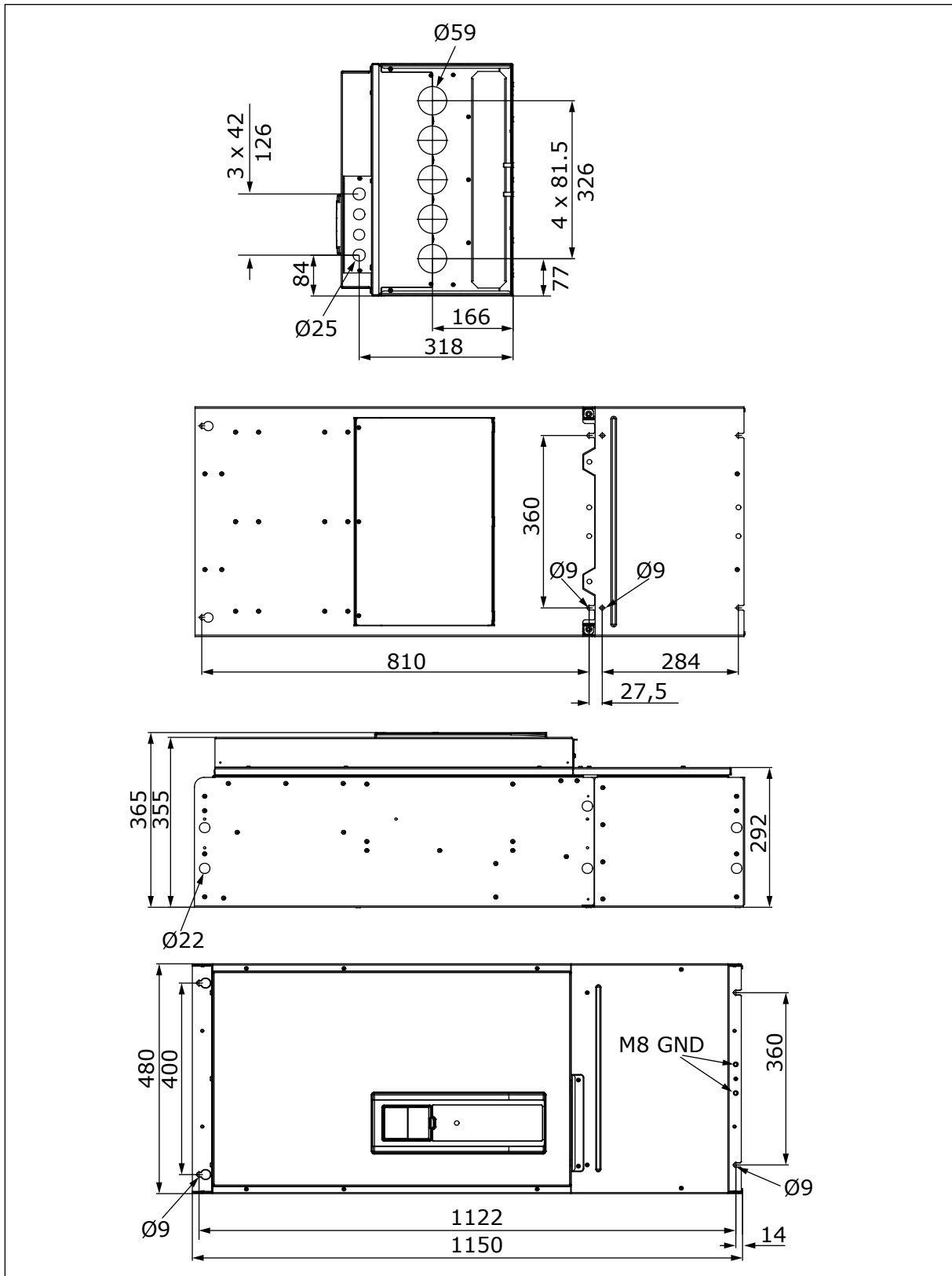

Fig. 8: The dimensions of the AC drive, MR9, IP21 and IP54 [mm]

4.2.8 WALL MOUNTING OF MR9, IP00

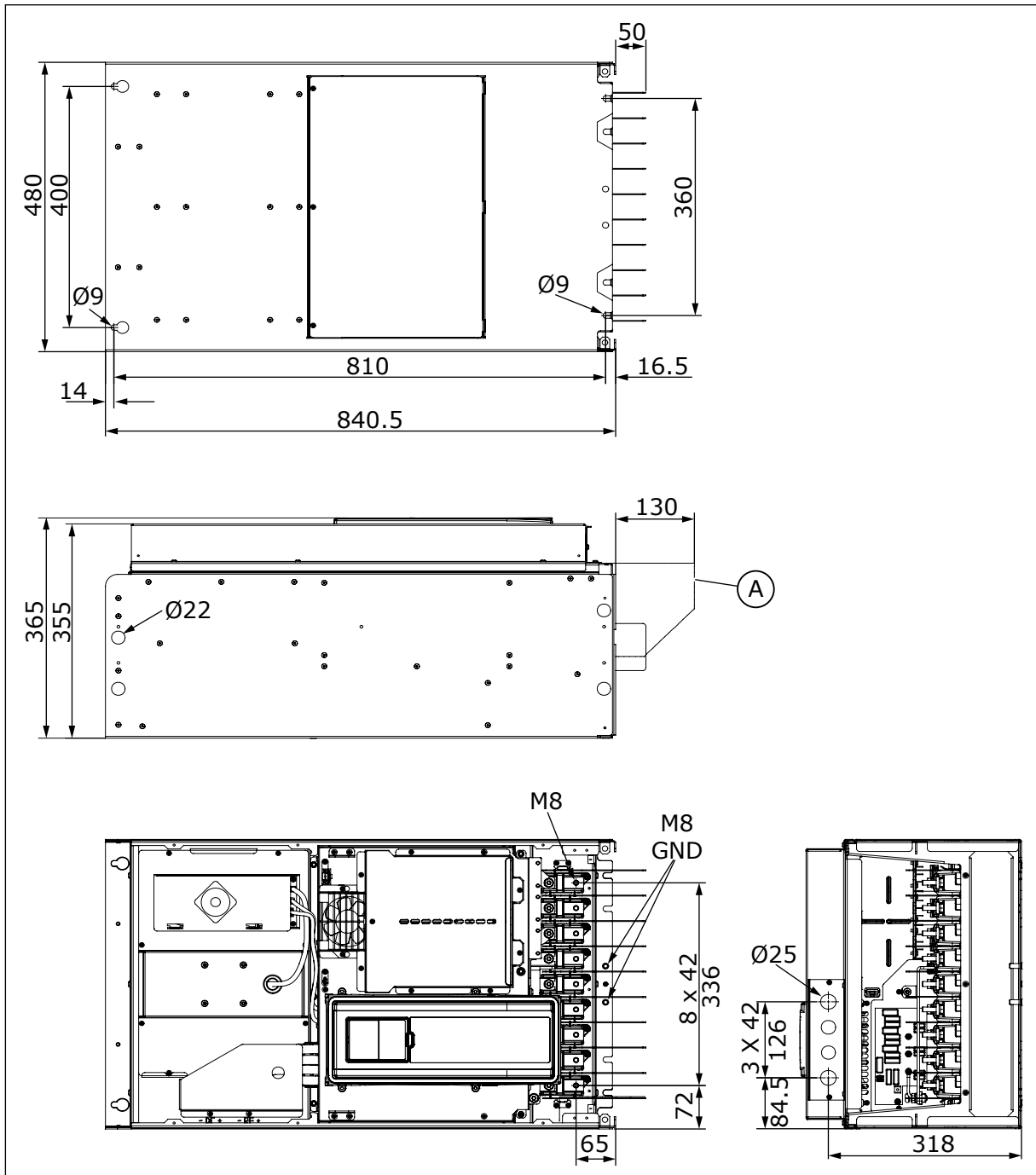

Fig. 9: The dimensions of the AC drive, MR9, IP00 [mm]

- A. An optional main connector cover for the cabinet installation

4.3 DIMENSIONS FOR WALL MOUNTING, NORTH AMERICA

4.3.1 WALL MOUNTING OF MR4, NORTH AMERICA

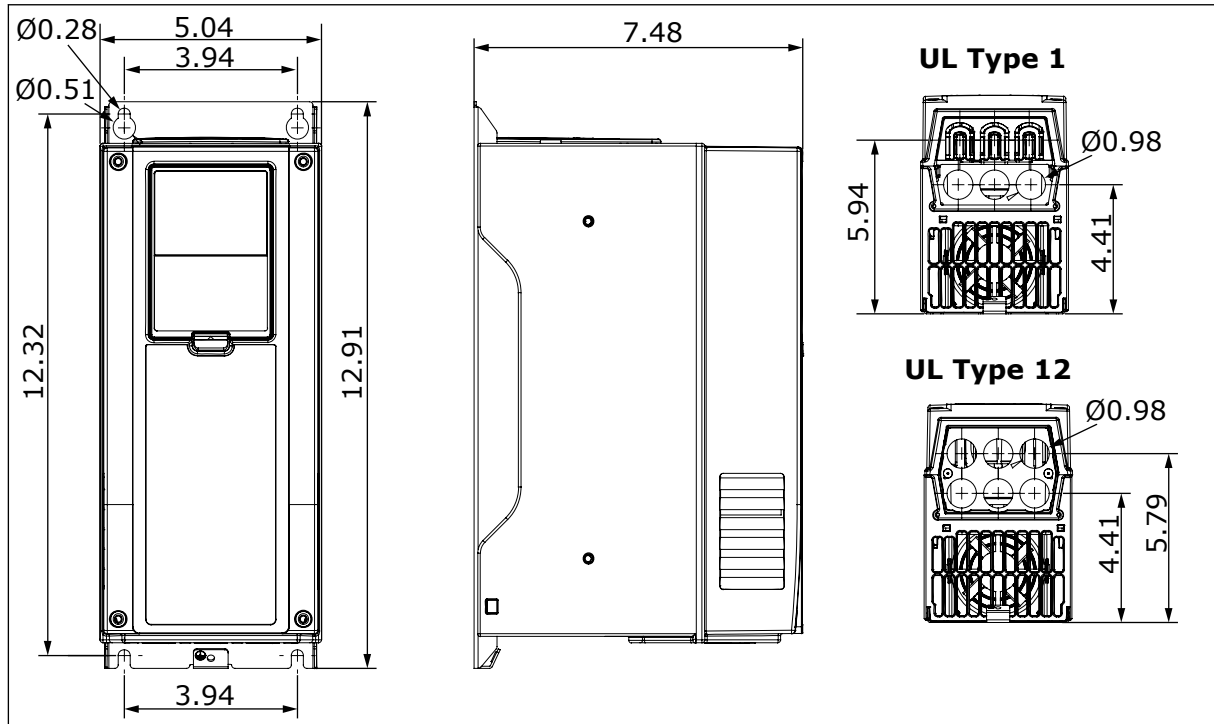

Fig. 10: The dimensions of the AC drive, MR4 [in]

4.3.2 WALL MOUNTING OF MR5, NORTH AMERICA

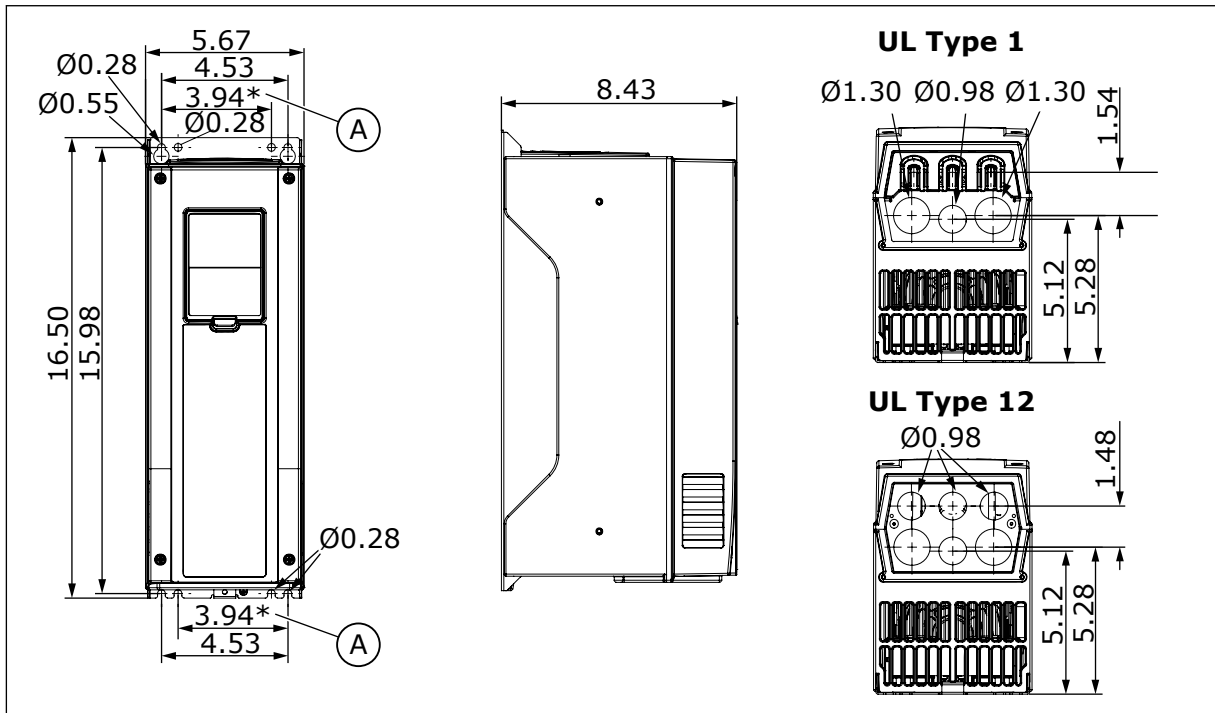

Fig. 11: The dimensions of the AC drive, MR5 [in]

- A. Use these mounting holes when you replace your Vacon® NX AC drive with a Vacon® 100, Vacon® 100 FLOW or Vacon® 100 HVAC AC drive.

4.3.3 WALL MOUNTING OF MR6, NORTH AMERICA

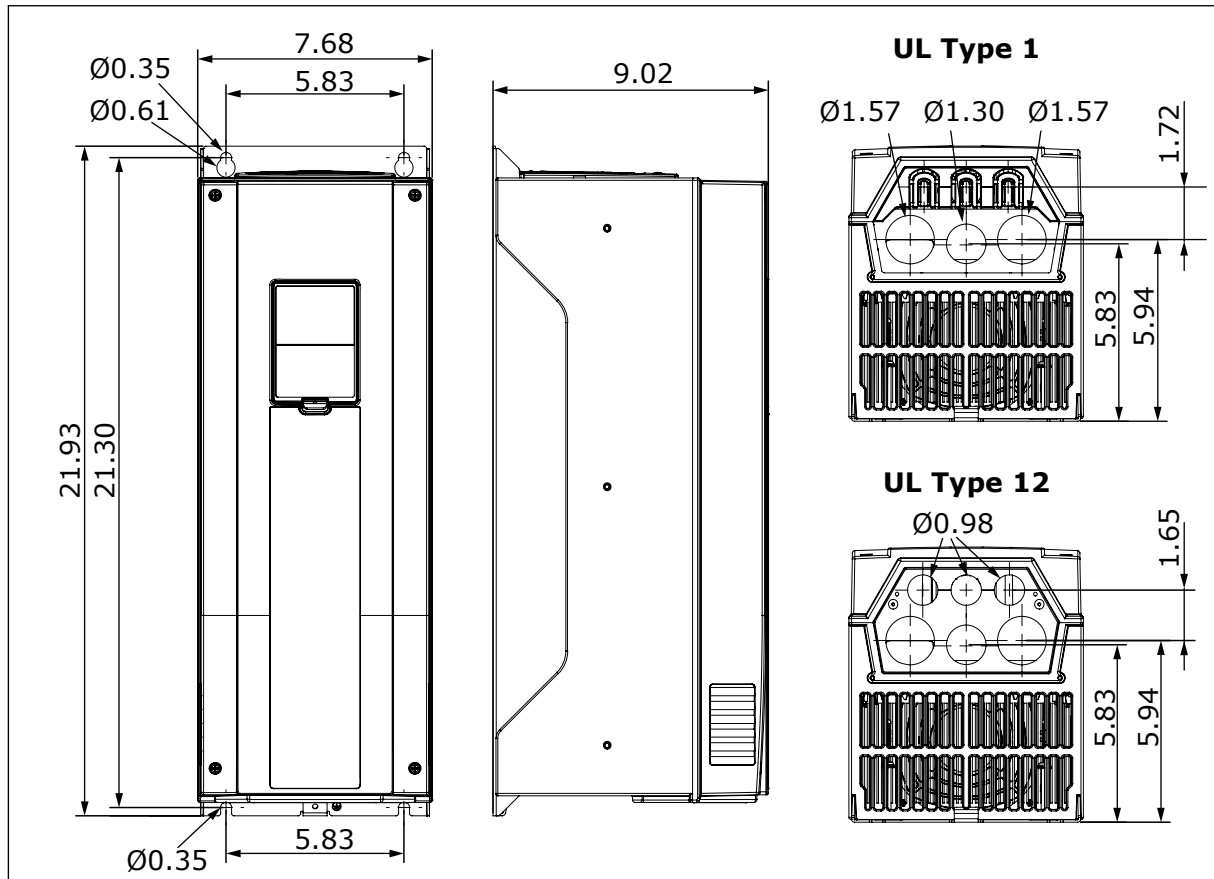

Fig. 12: The dimensions of the AC drive, MR6 [in]

4.3.4 WALL MOUNTING OF MR7, NORTH AMERICA

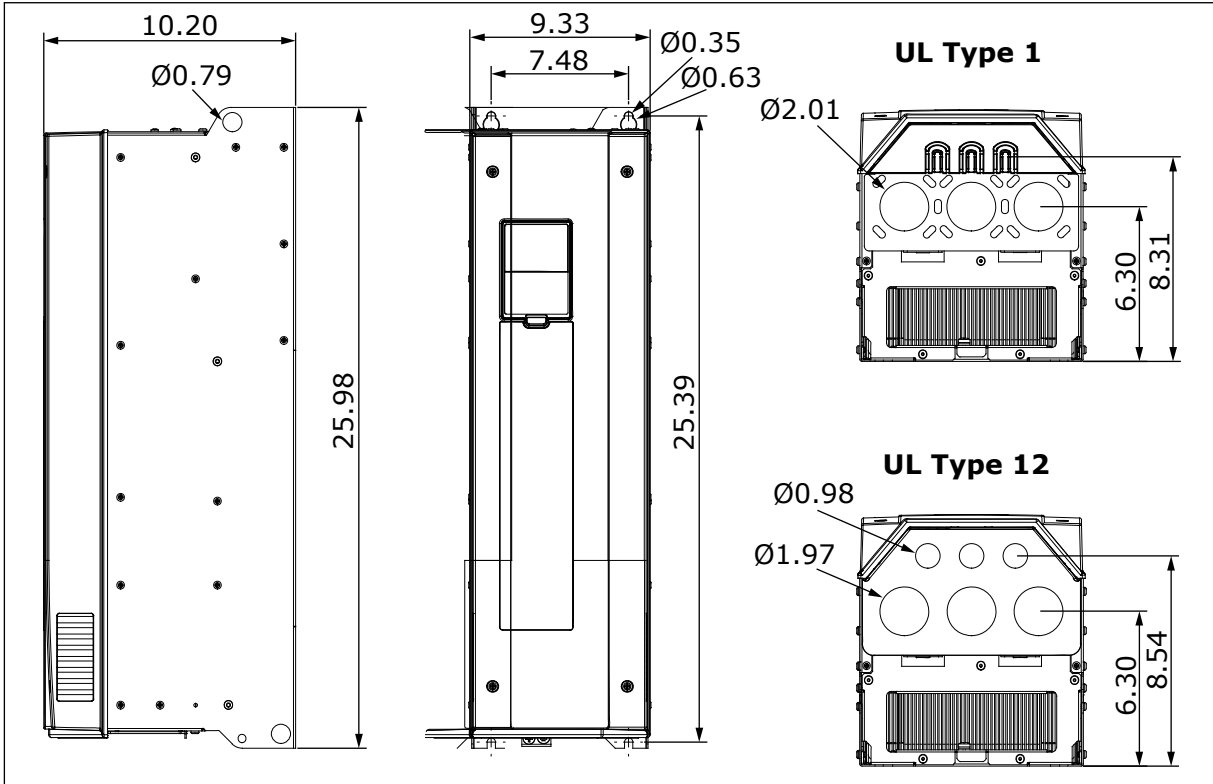

Fig. 13: The dimensions of the AC drive, MR7 [in]

4.3.5 WALL MOUNTING OF MR8, NORTH AMERICA

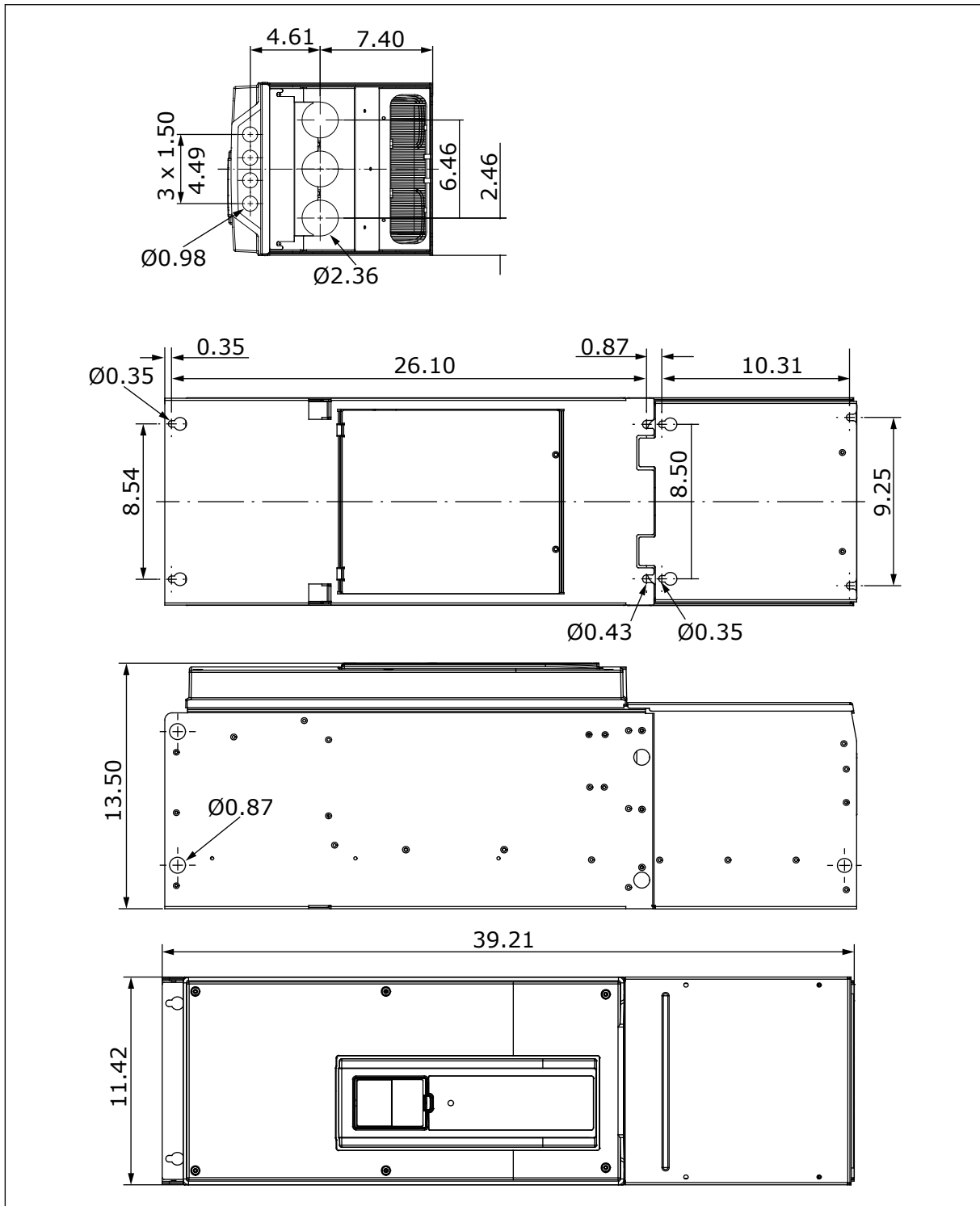

Fig. 14: The dimensions of the AC drive, MR8 [in]

4.3.6 WALL MOUNTING OF MR8, UL OPEN TYPE, NORTH AMERICA

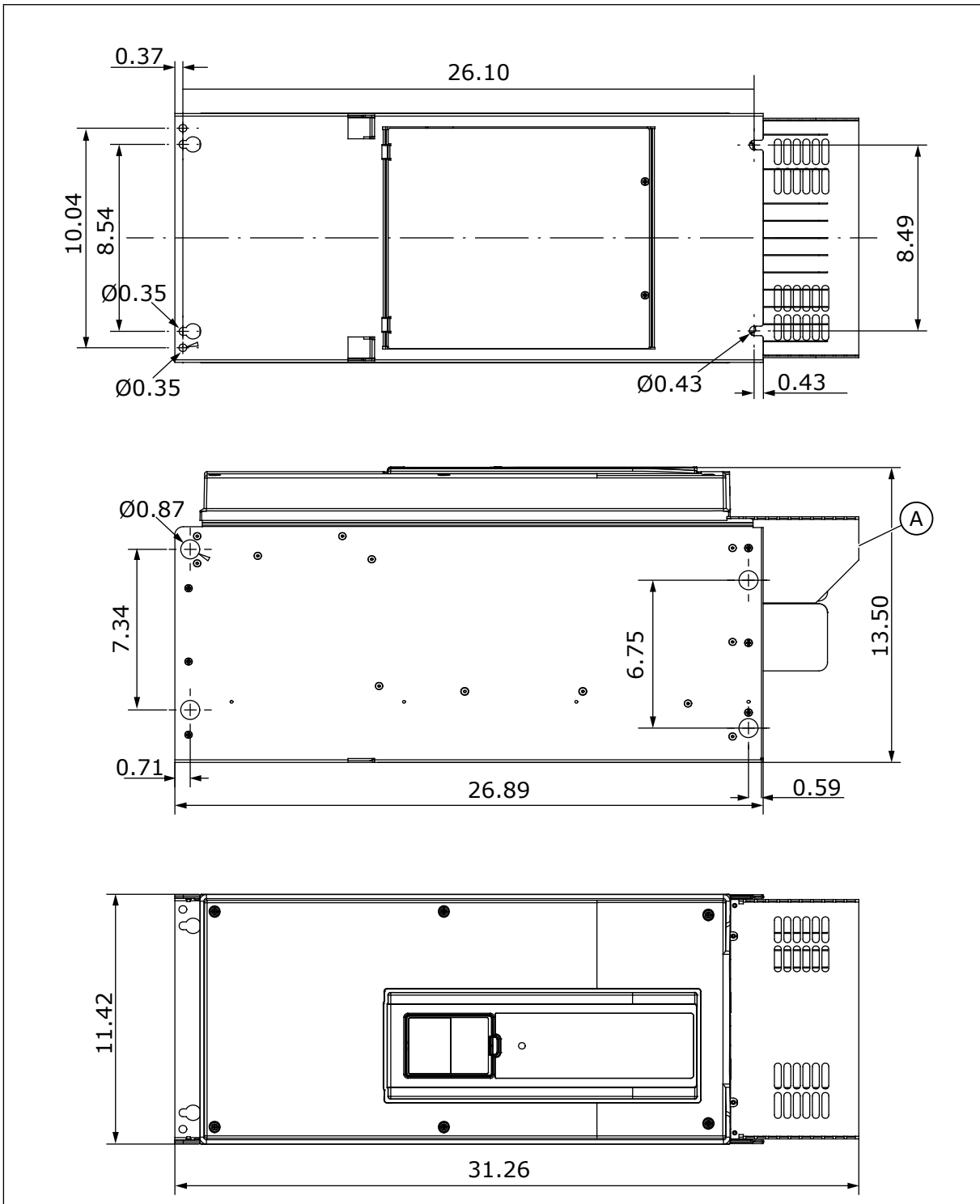

Fig. 15: The dimensions of the AC drive, MR8, UL Open Type [in]

- A. An optional main connector cover for the cabinet installation

4.3.7 WALL MOUNTING OF MR9, NORTH AMERICA

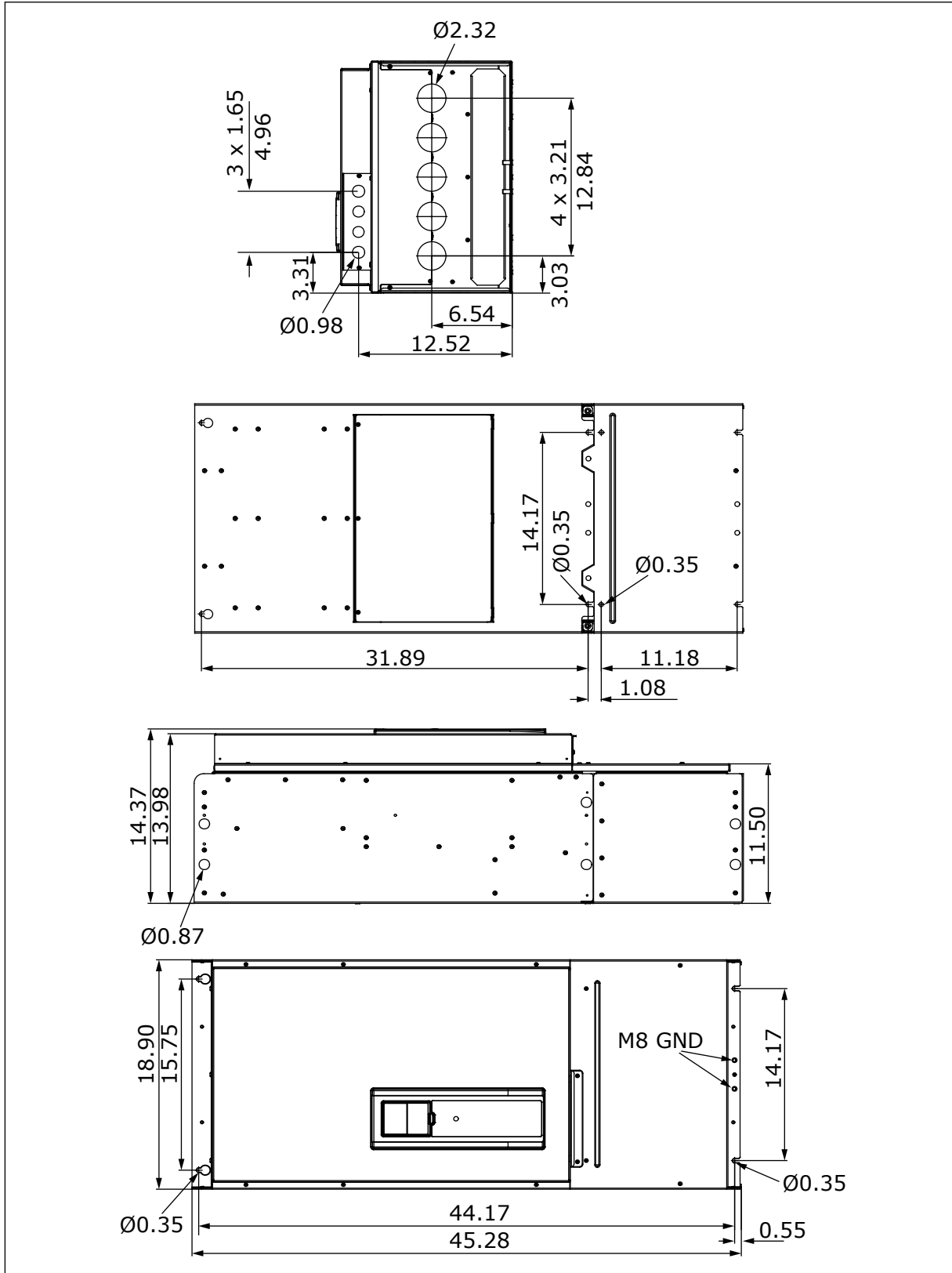

Fig. 16: The dimensions of the AC drive, MR9 [in]

4.3.8 WALL MOUNTING OF MR9, UL OPEN TYPE, NORTH AMERICA

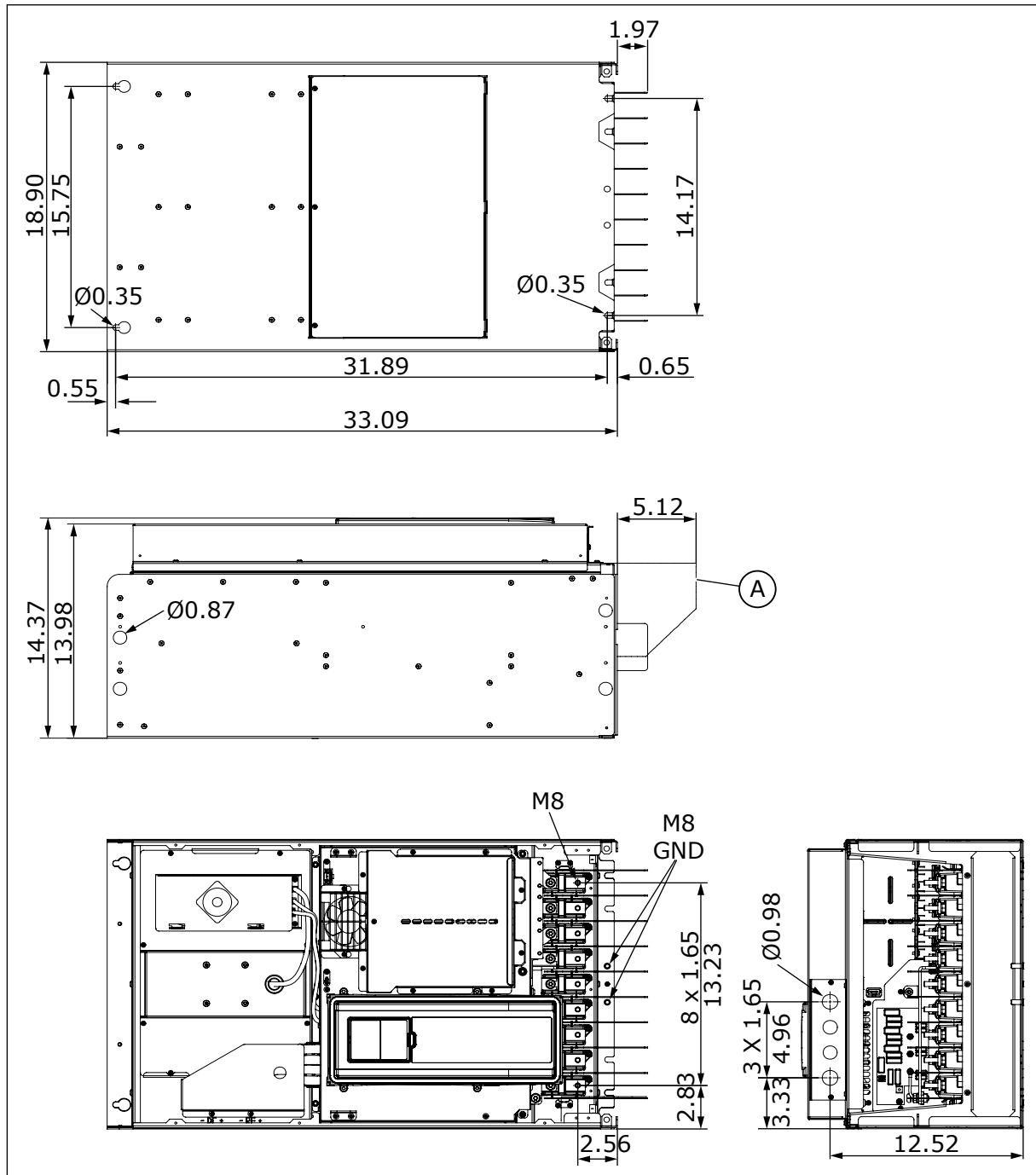

Fig. 17: The dimensions of the AC drive, MR9, UL Open Type [in]

A. An optional main connector cover for the cabinet installation

4.4 DIMENSIONS FOR FLANGE MOUNTING

You can also install the AC drive into the cabinet wall with a flange mounting option.

**NOTE!**

The protection classes are different in different sections of the drive.

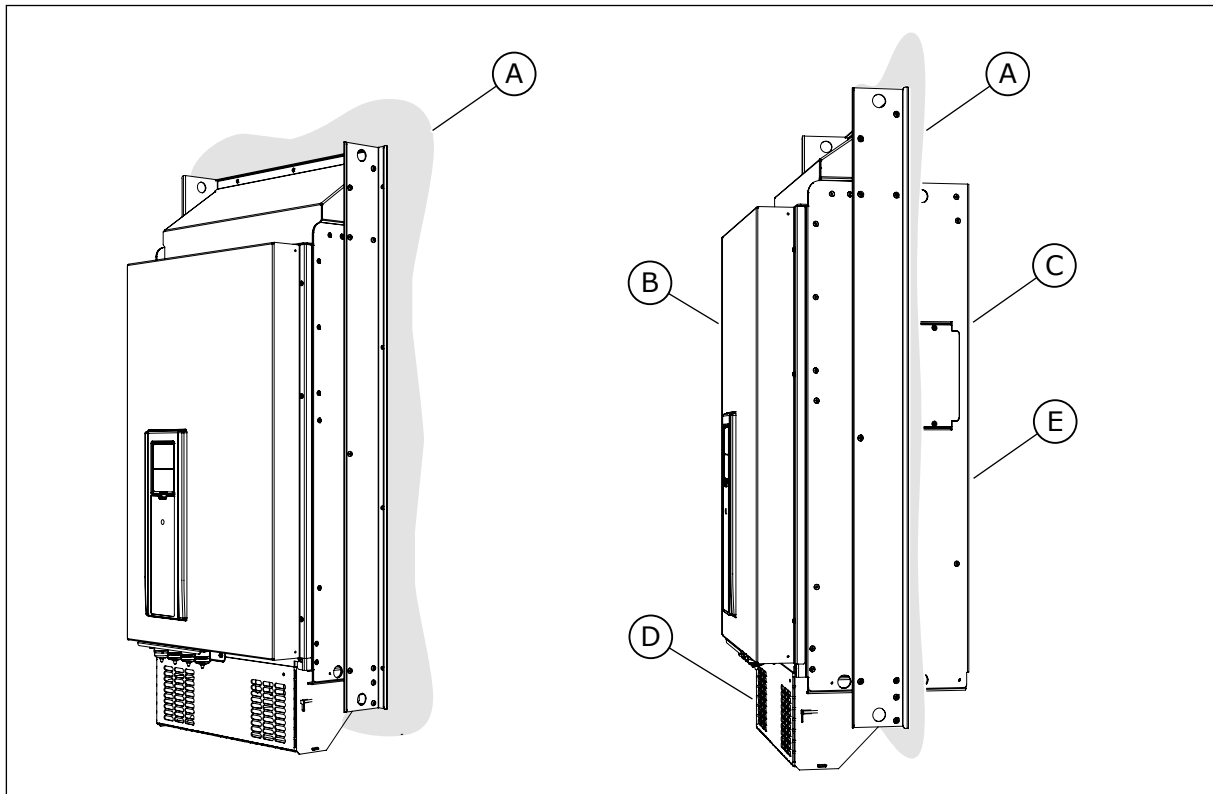

Fig. 18: Example of flange mounting (frame MR9)

- A. The cabinet wall or other surface
- B. The front
- C. The rear

- D. IP00 / UL Open Type
- E. IP54 / UL Type 12

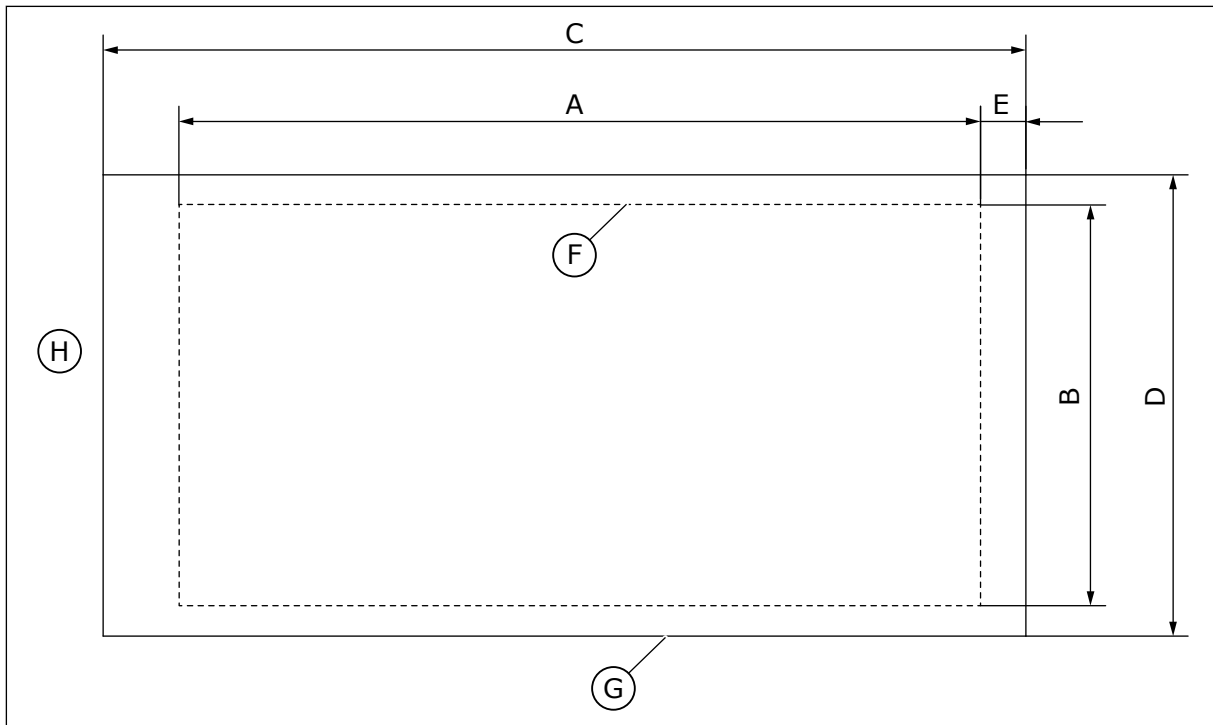

Fig. 19: The dimensions of the opening and drive outline with flange

- A. The height of the opening for the flange mounting
- B. The width of the opening
- C. The height of the drive
- D. The width of the drive
- E. The distance between the bottom of the drive and the bottom of the opening
- F. The outline of the opening
- G. The outline of the drive
- H. The top of the drive

Table 11: The dimensions of the drive, frames MR4 to MR9

Frame	C [mm]	D [mm]	C [in]	D [in]
MR4	357	152	14.1	6.0
MR5	454	169	17.9	6.7
MR6	580	220	22.8	8.7
MR7	680	286	26.8	11.3
MR8	898	359	35.4	14.1
MR9	1060	550	41.7	21.7

Table 12: The dimensions of the opening for the flange mounting, frames MR4 to MR9

Frame	A [mm]	B [mm]	E [mm]	A [in]	B [in]	E [in]
MR4	315	137	24	12.4	5.4	0.9
MR5	408	152	23	16.1	6.0	0.9
MR6	541	203	23	21.3	8.0	0.9
MR7	655	240	13	25.8	9.4	0.5
MR8	859	298	18	33.8	11.7	0.7
MR9	975	485	54	38.4	19.1	2.1

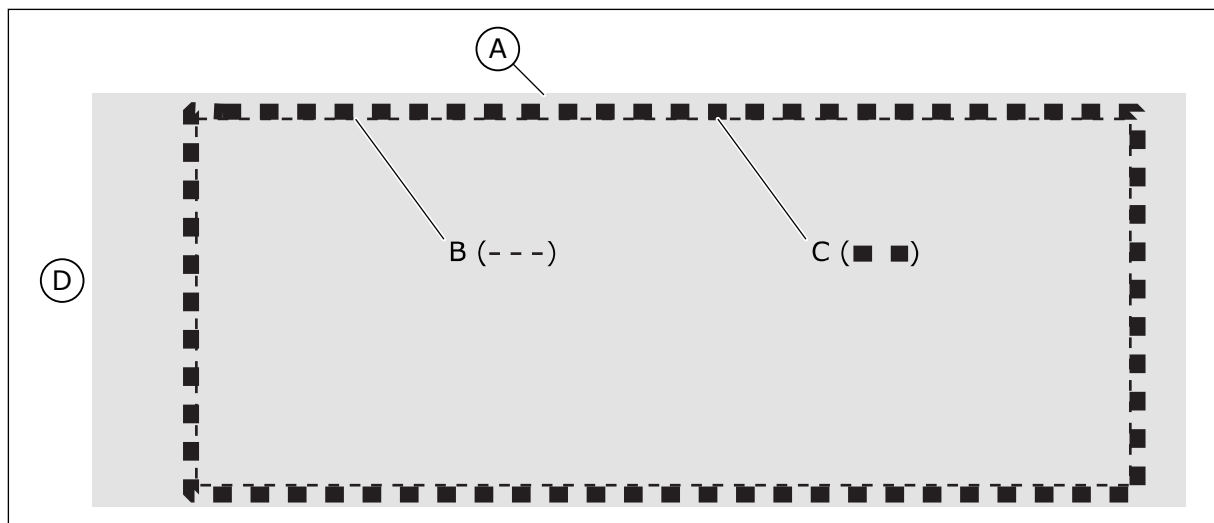
**Fig. 20: Sealing of the opening for MR8 and MR9**

- A. The AC drive
- B. The outline of the opening
- C. Gasket tape
- D. The top of the drive

4.4.1 FLANGE MOUNTING OF MR4

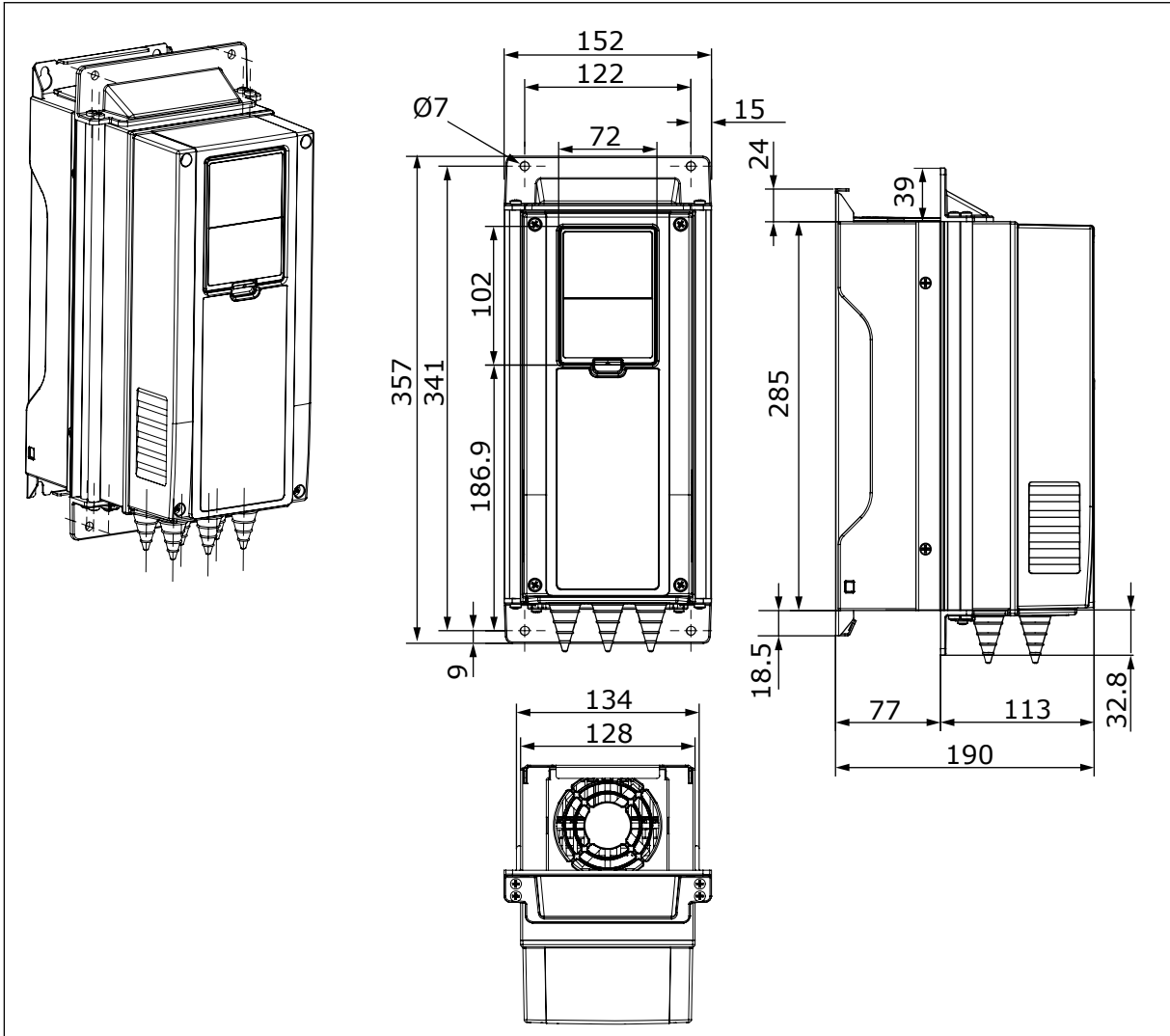

Fig. 21: The dimensions of the AC drive, flange mounting, MR4 [mm]

4.4.2 FLANGE MOUNTING OF MR5

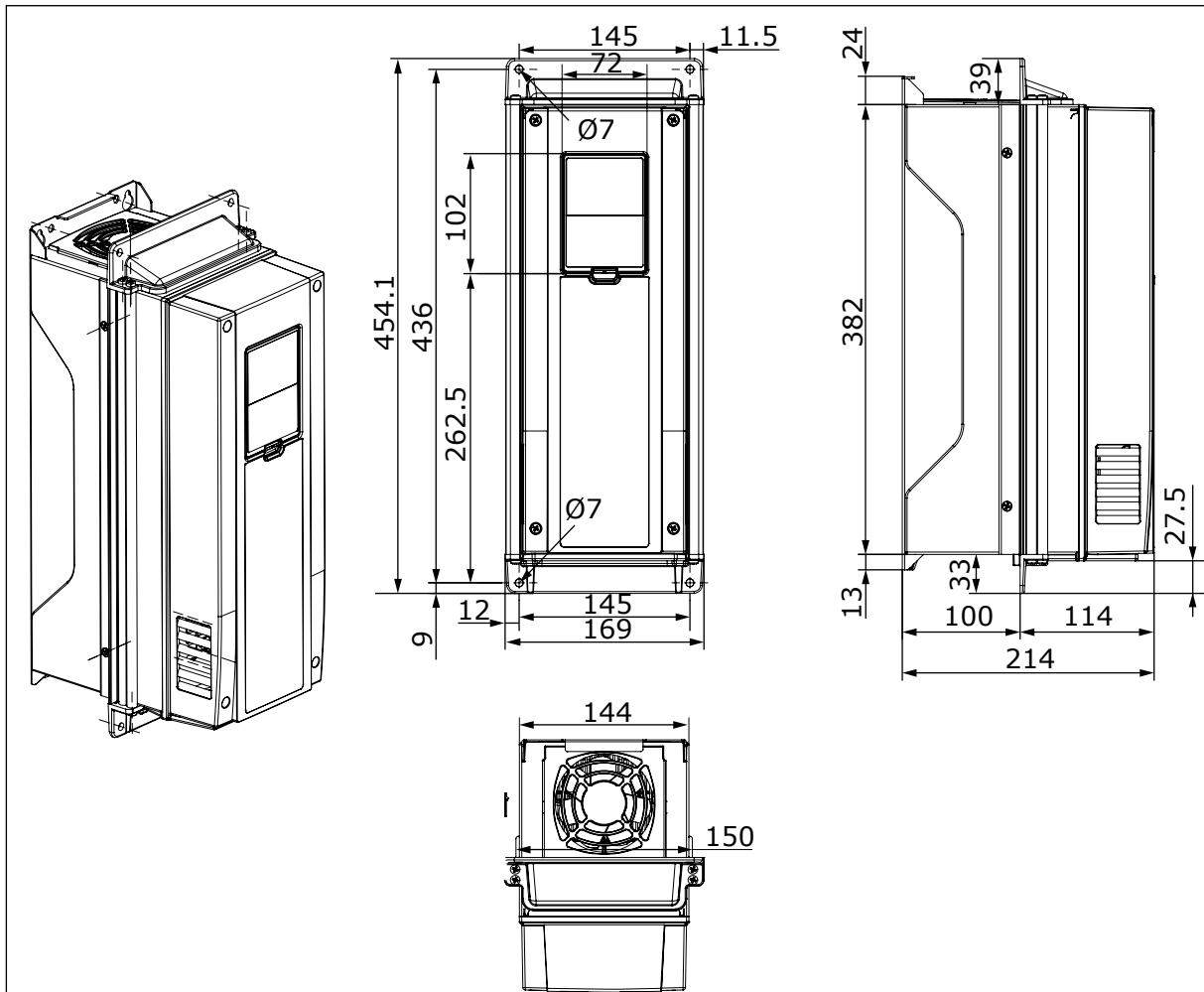

Fig. 22: The dimensions of the AC drive, flange mounting, MR5 [mm]

4.4.3 FLANGE MOUNTING OF MR6

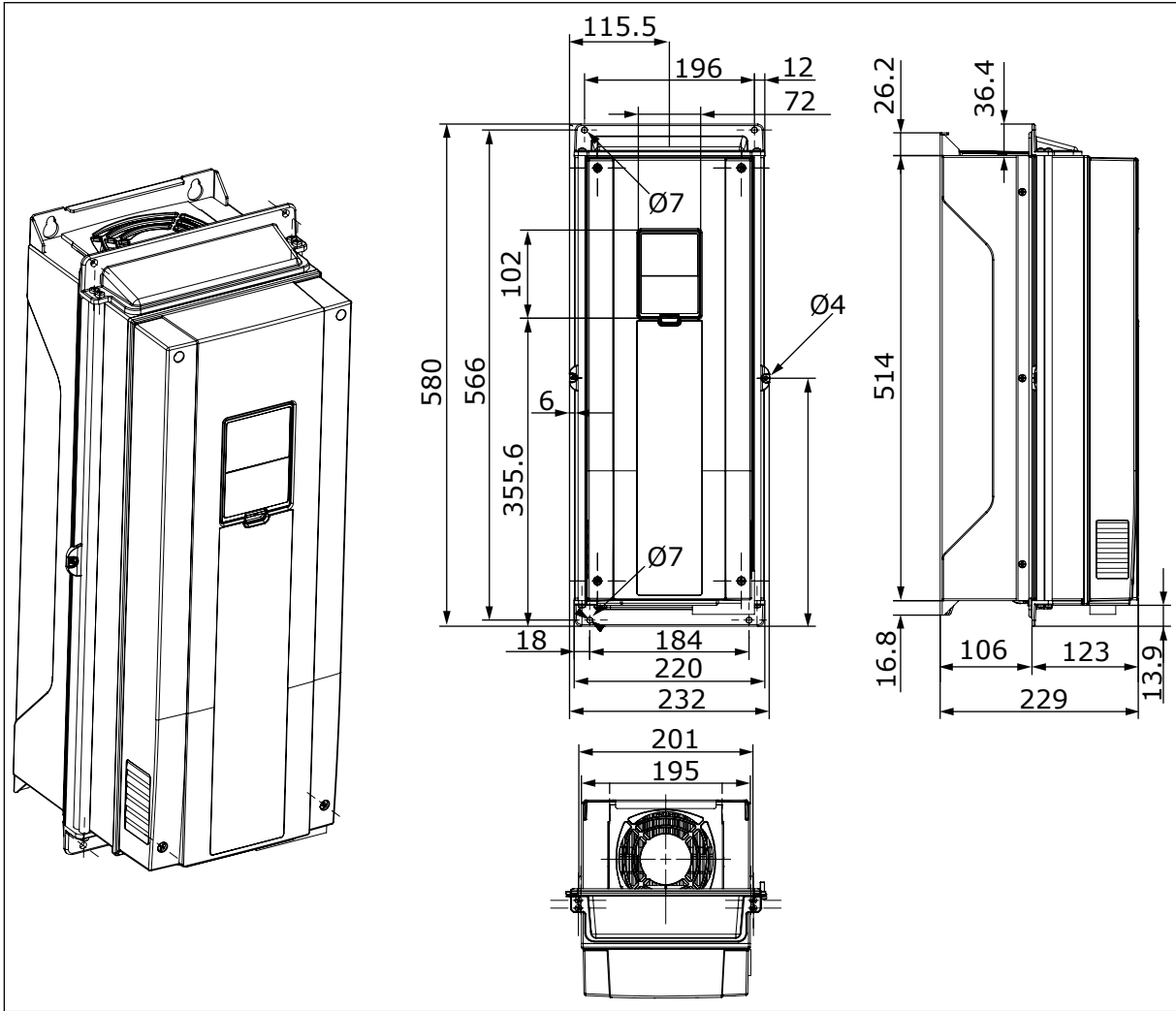

Fig. 23: The dimensions of the AC drive, flange mounting, MR6 [mm]

4.4.4 FLANGE MOUNTING OF MR7

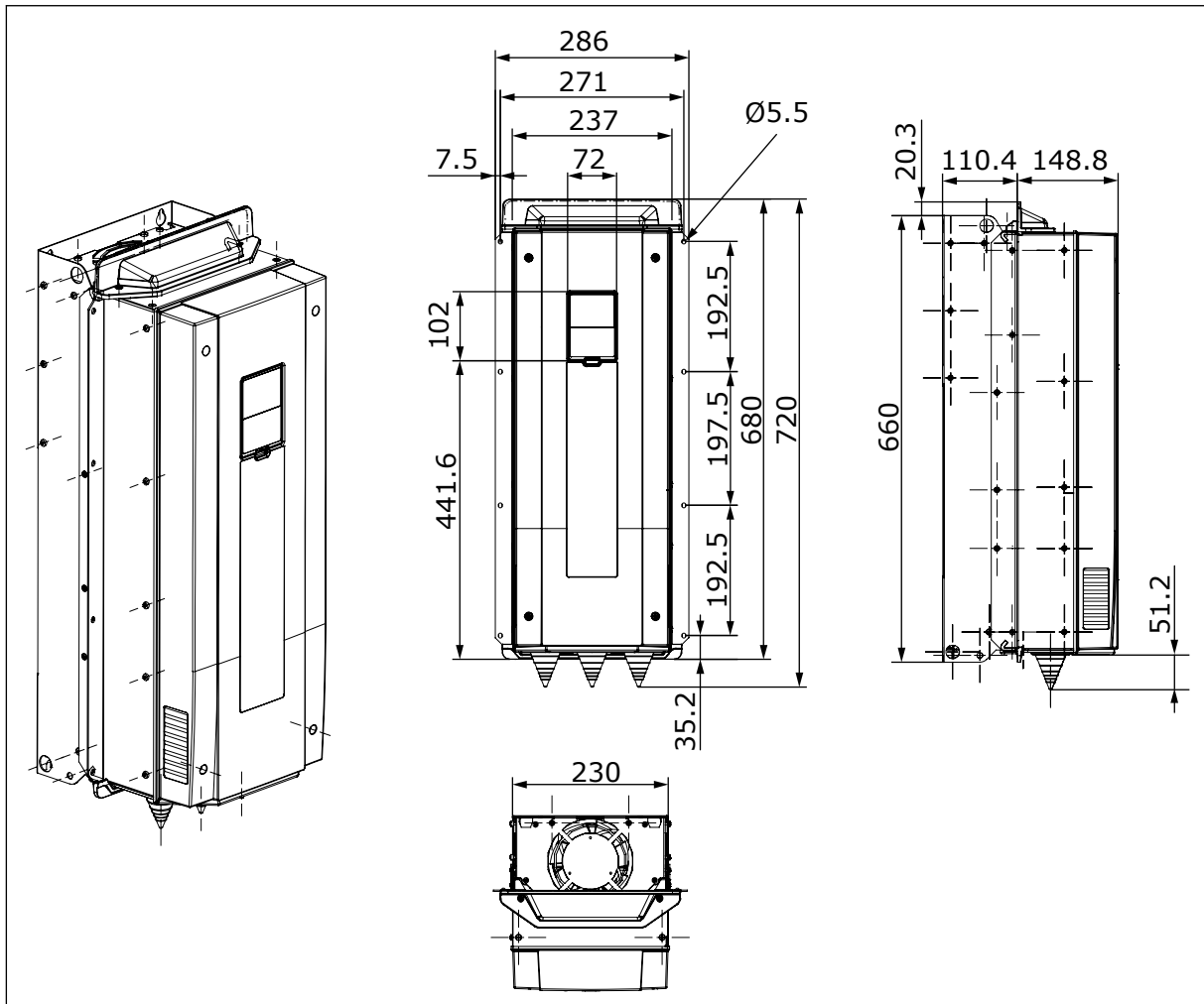

Fig. 24: The dimensions of the AC drive, flange mounting, MR7 [mm]

4.4.5 FLANGE MOUNTING OF MR8

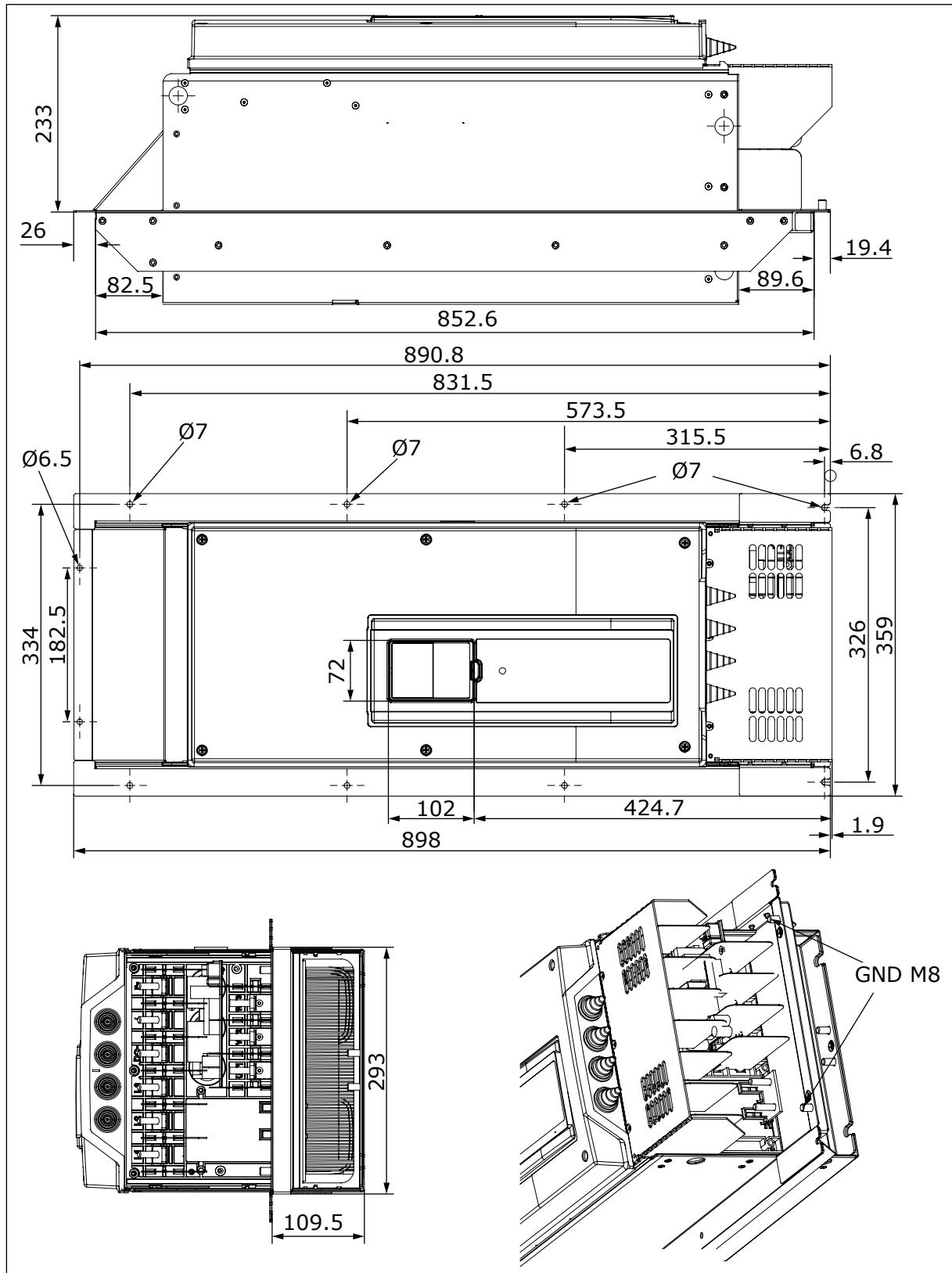

Fig. 25: The dimensions of the AC drive, flange mounting, MR8 [mm]

4.4.6 FLANGE MOUNTING OF MR9

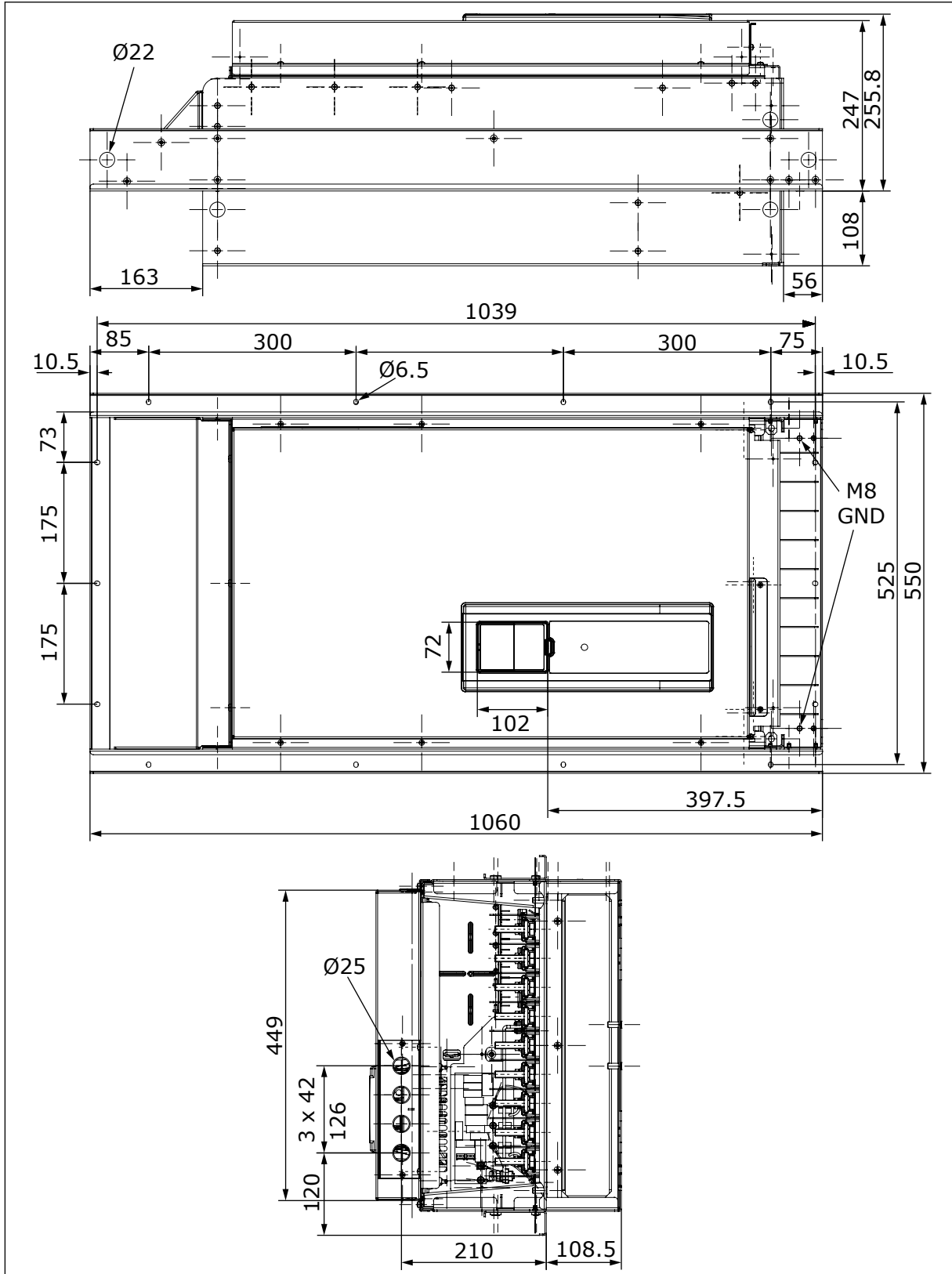

Fig. 26: The dimensions of the AC drive, flange mounting, MR9 [mm]

4.5 DIMENSIONS FOR FLANGE MOUNTING, NORTH AMERICA

4.5.1 FLANGE MOUNTING OF MR4, NORTH AMERICA

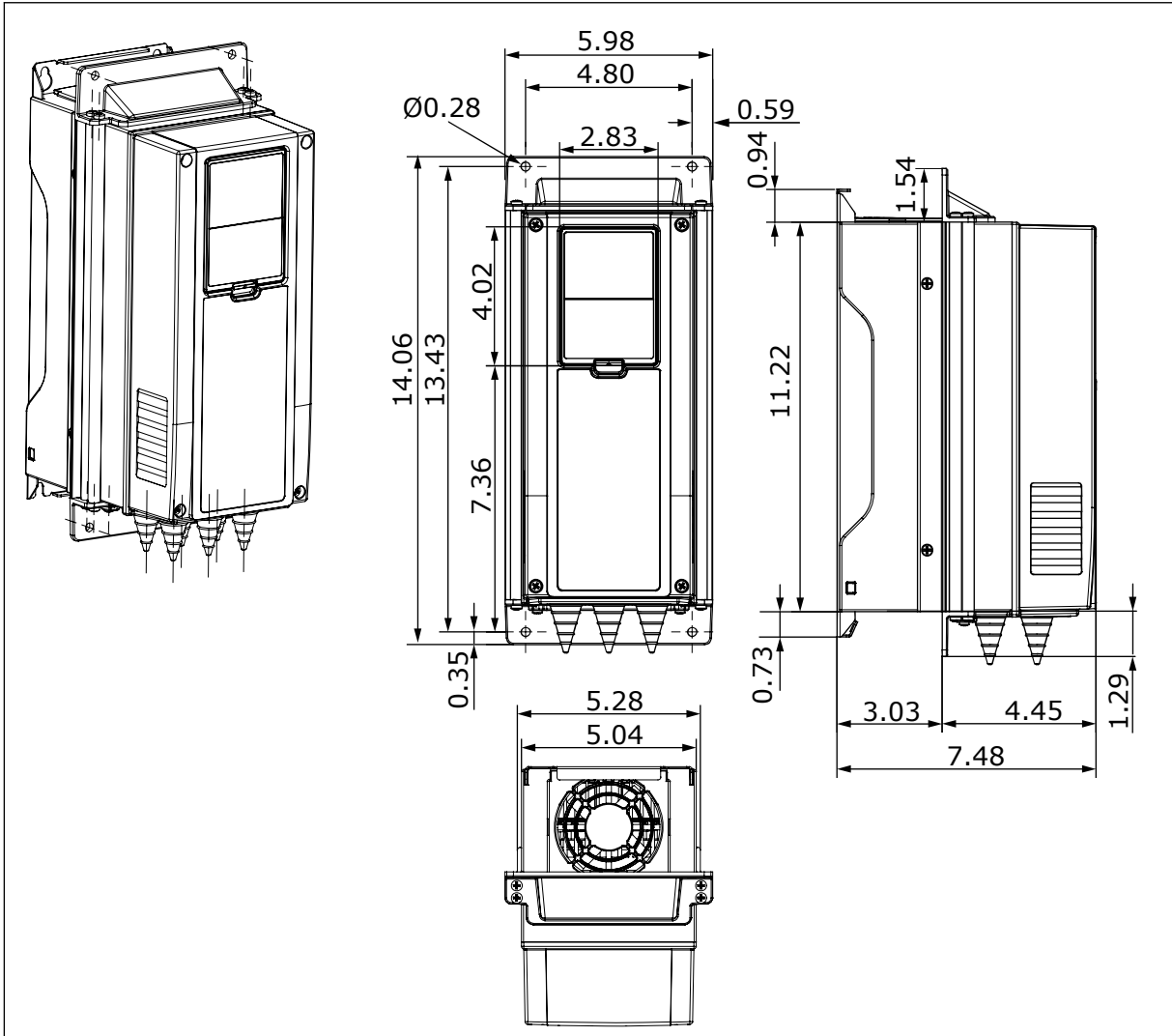

Fig. 27: The dimensions of the AC drive, flange mounting, MR4 [in]

4.5.2 FLANGE MOUNTING OF MR5, NORTH AMERICA

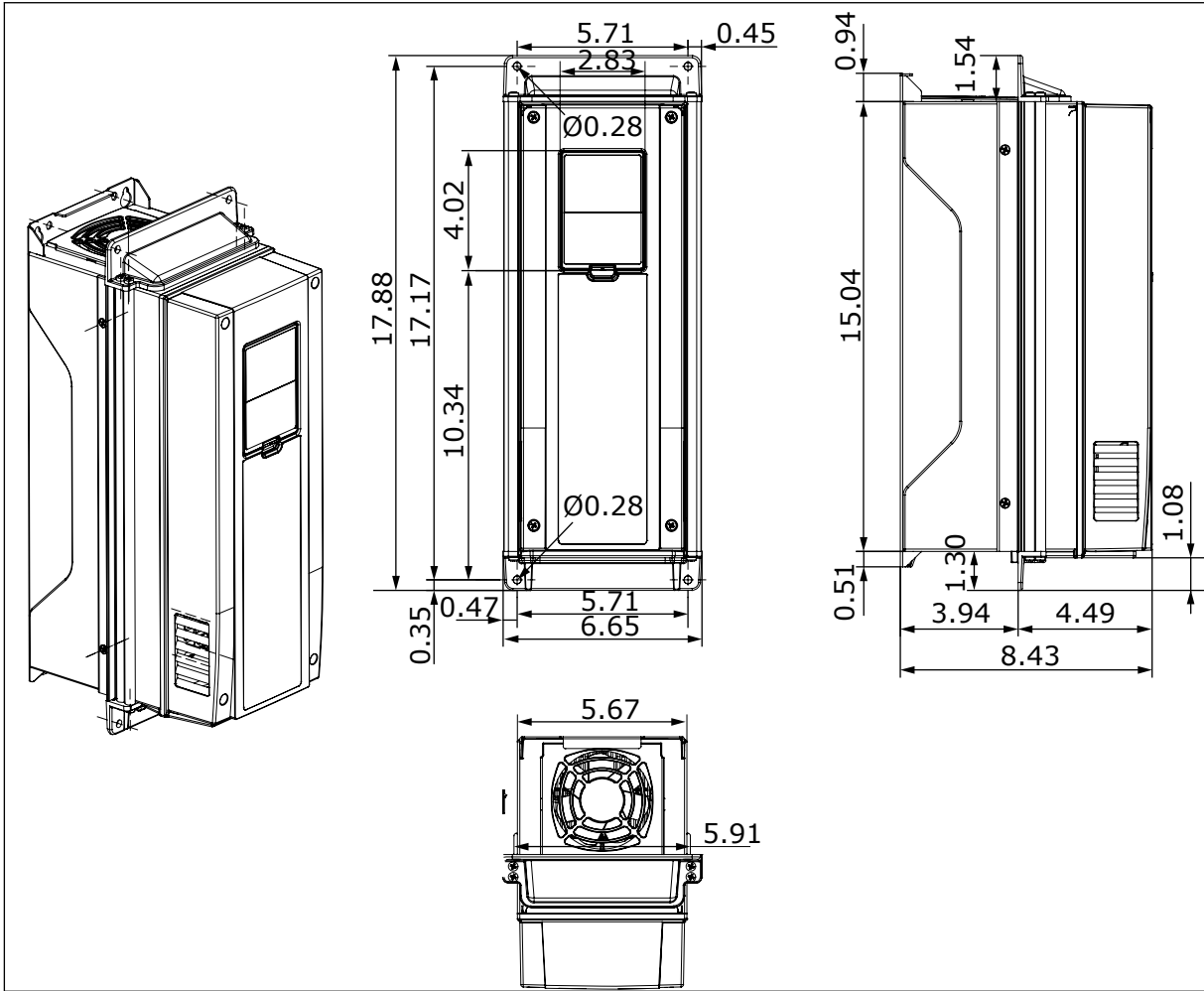

Fig. 28: The dimensions of the AC drive, flange mounting, MR5 [in]

4.5.3 FLANGE MOUNTING OF MR6, NORTH AMERICA

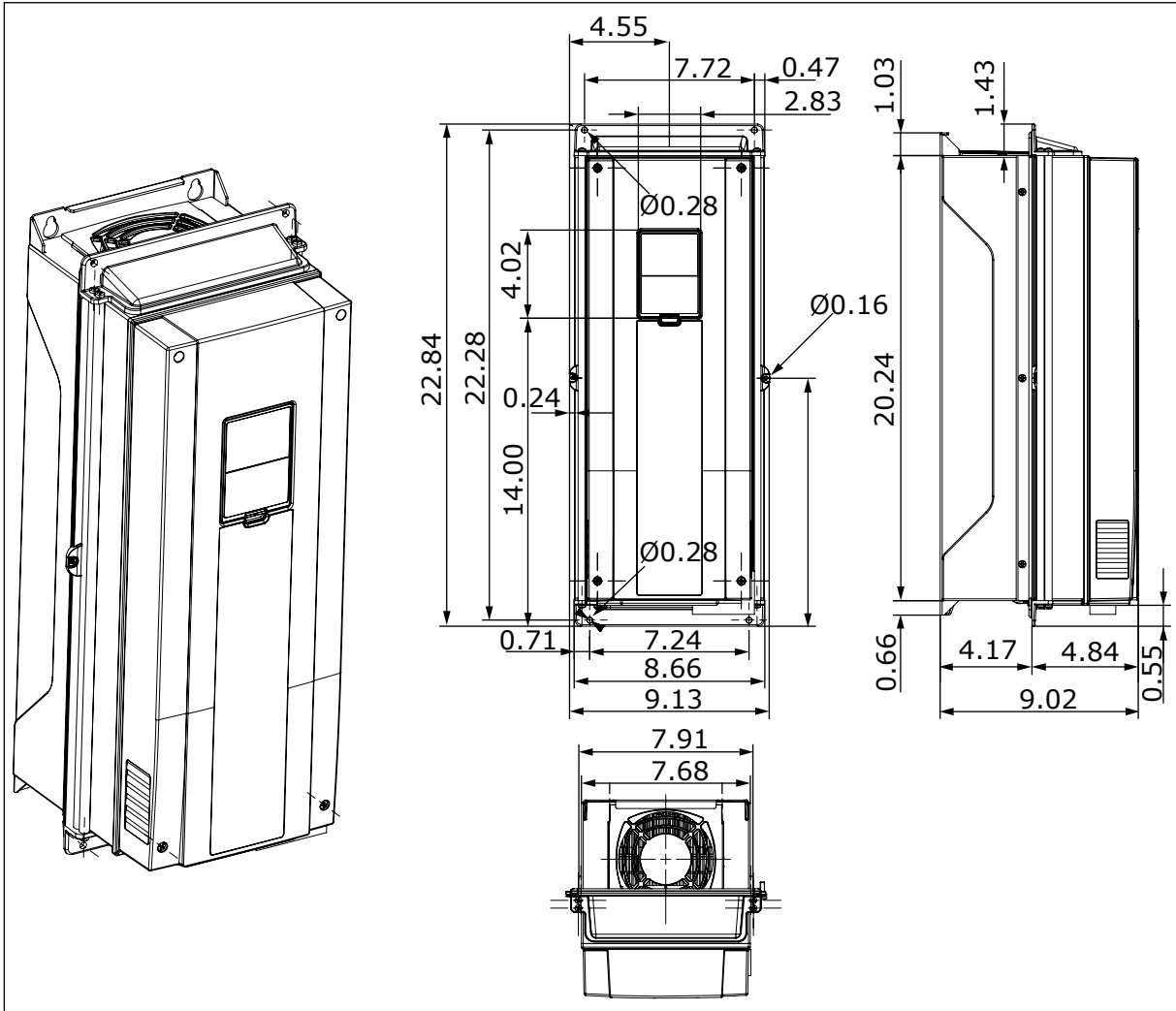

Fig. 29: The dimensions of the AC drive, flange mounting, MR6 [in]

4.5.4 FLANGE MOUNTING OF MR7, NORTH AMERICA

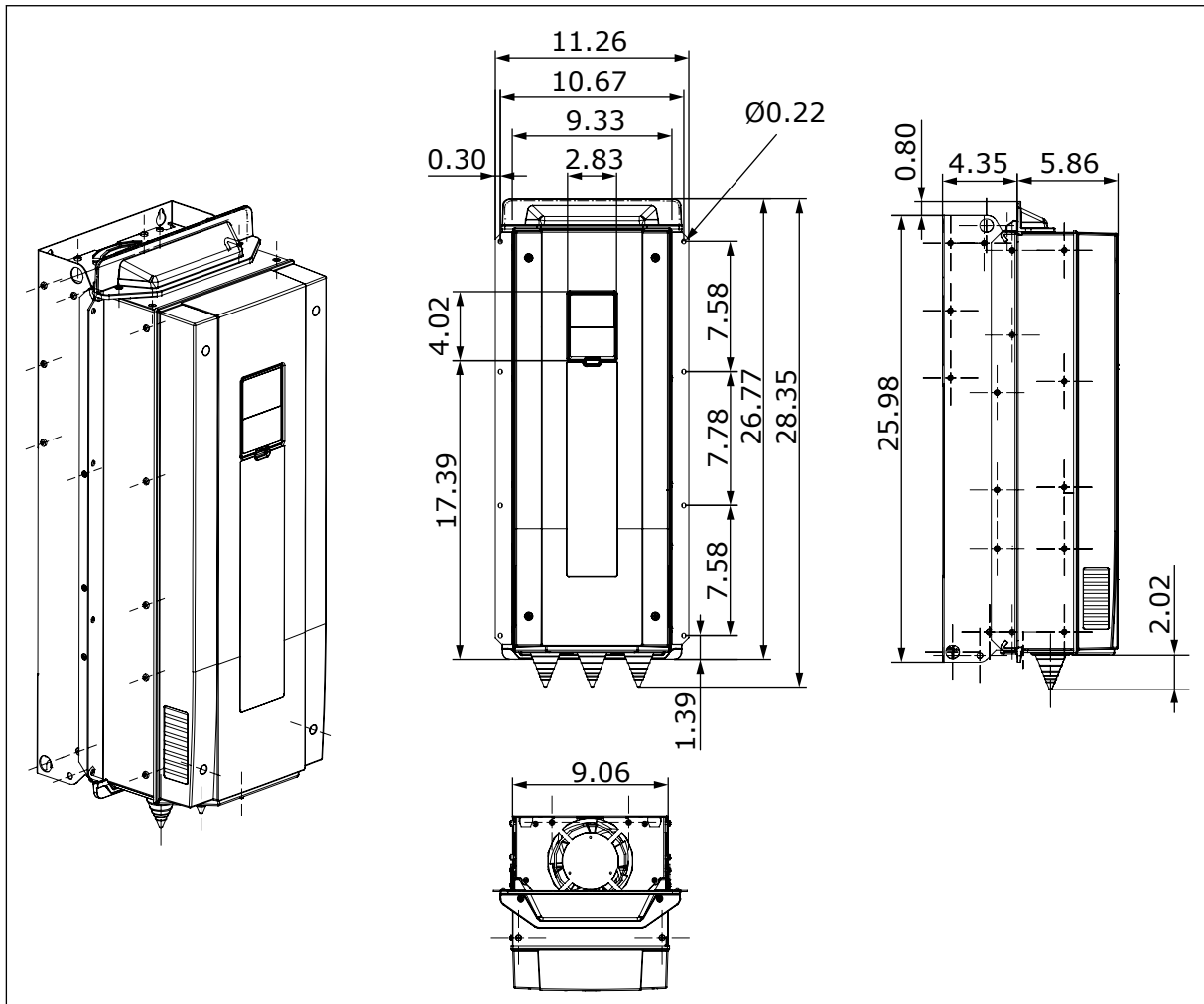

Fig. 30: The dimensions of the AC drive, flange mounting, MR7 [in]

4.5.5 FLANGE MOUNTING OF MR8, NORTH AMERICA

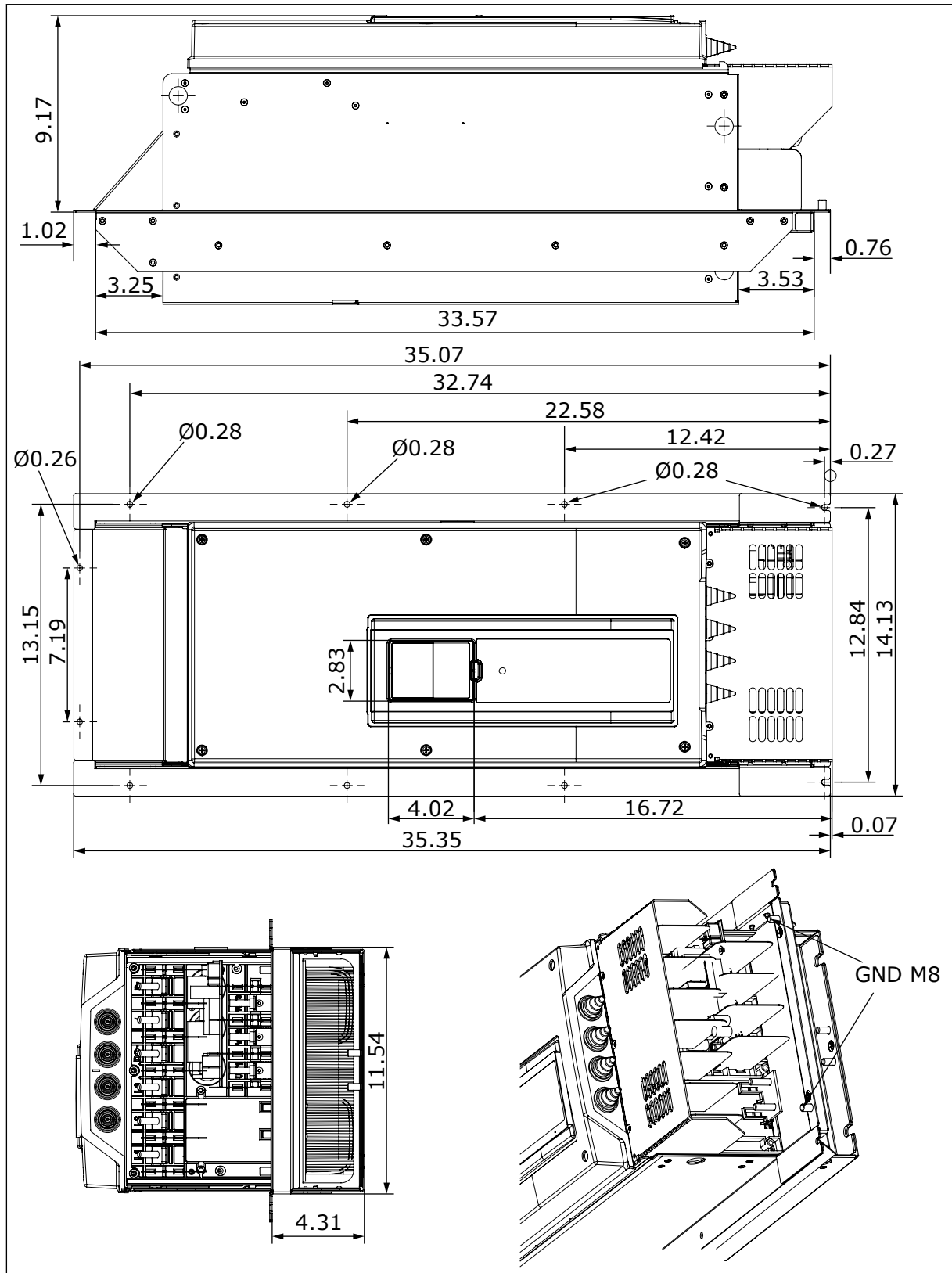

Fig. 31: The dimensions of the AC drive, flange mounting, MR8 [in]

4.5.6 FLANGE MOUNTING OF MR9, NORTH AMERICA

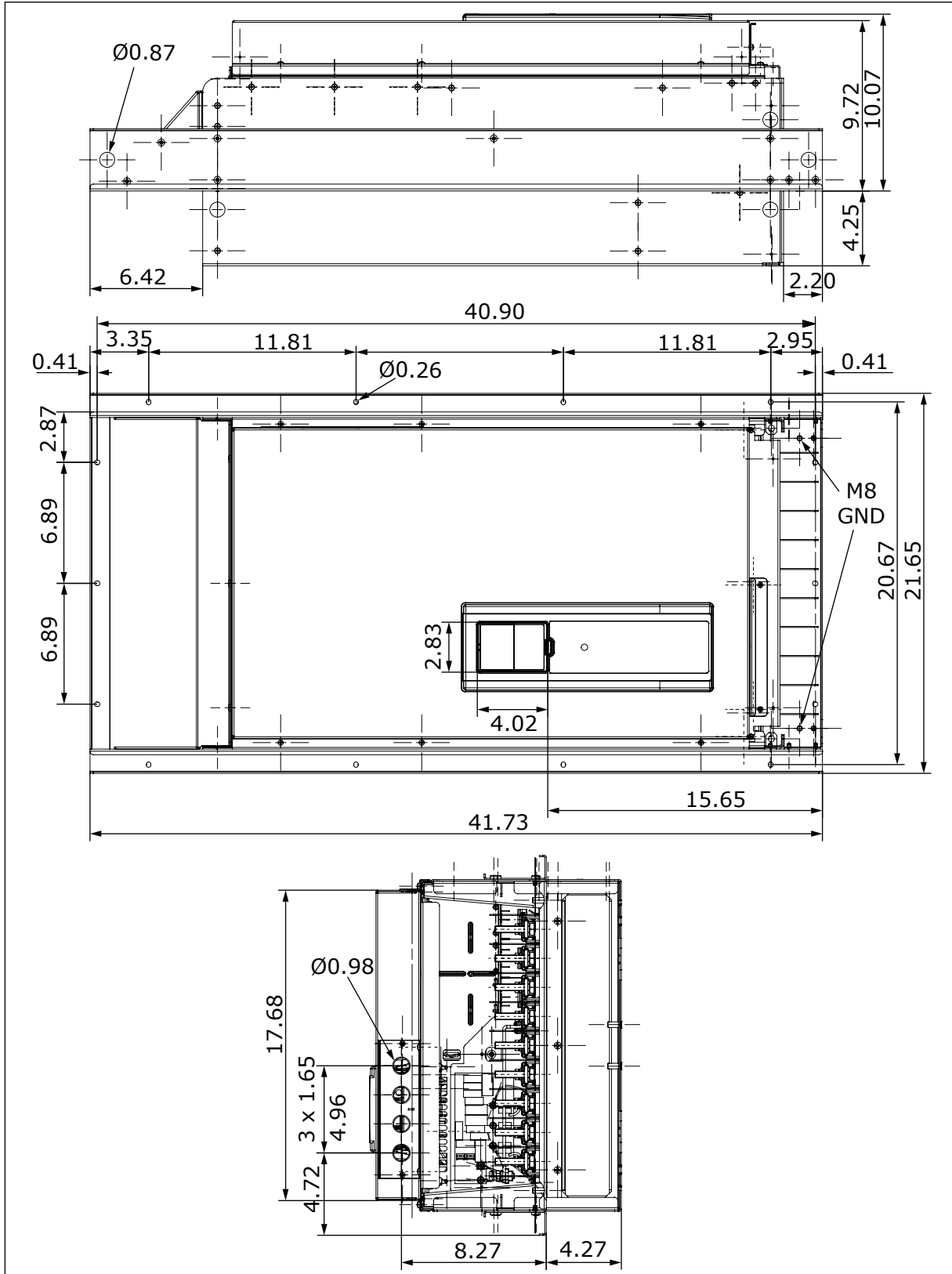

Fig. 32: The dimensions of the AC drive, flange mounting, MR9 [in]

4.6 COOLING

The AC drive produces heat in operation. The fan circulates air and decreases the temperature of the drive. Make sure that there is sufficiently free space around the drive. Some free space is also necessary for maintenance.

Make sure that the temperature of the cooling air does not become more than the maximum ambient operating temperature or less than the minimum ambient operating temperature of the drive.

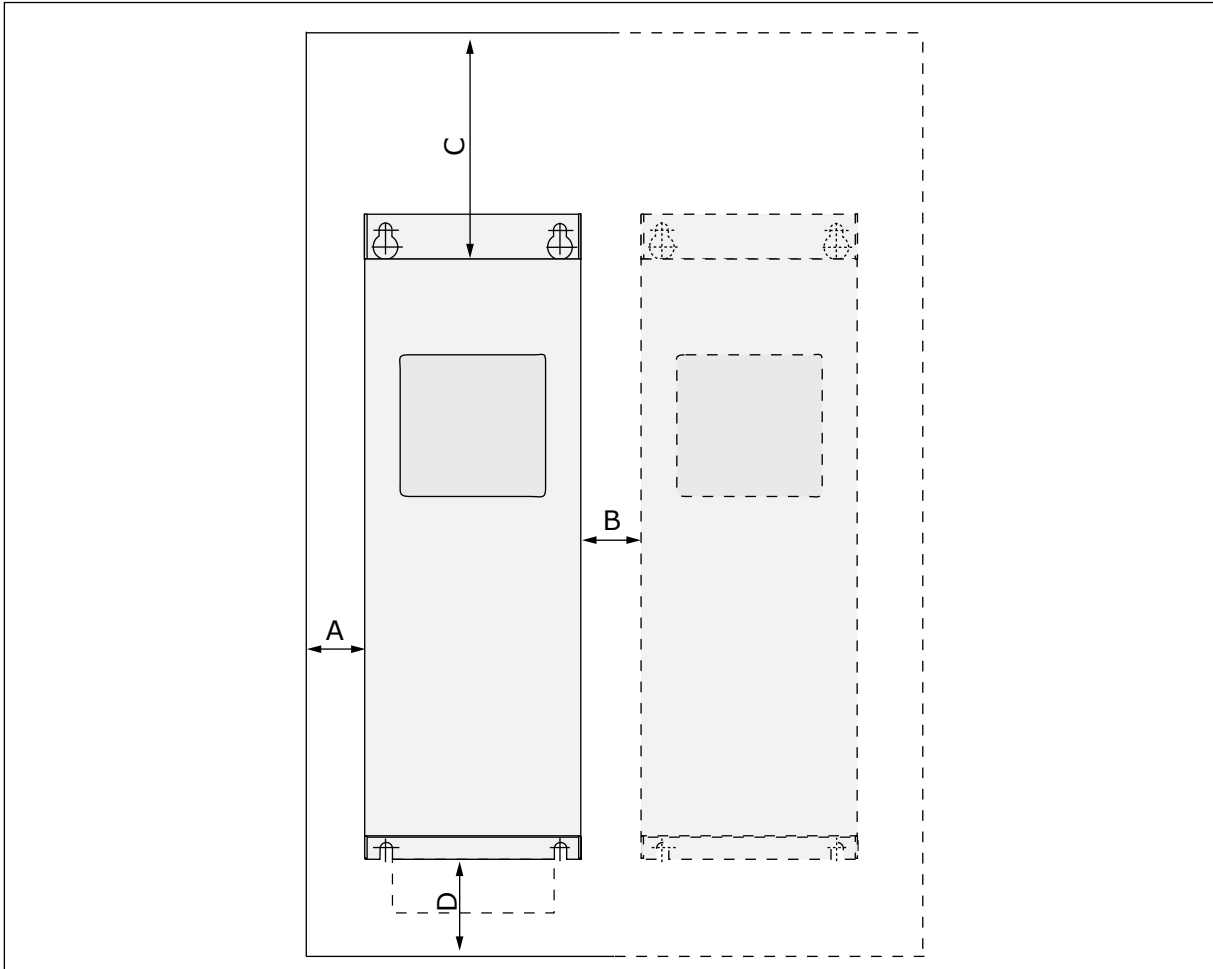

Fig. 33: Installation space

- | | |
|---|-----------------------------------|
| A. the clearance around the drive | C. the free space above the drive |
| B. the distance from a drive to a second drive, or the distance to the cabinet wall | D. the free space below the drive |

Table 13: The minimum clearances around the AC drive

Minimum clearance [mm]					Minimum clearance [in]			
Frame	A *	B *	C	D	A *	B *	C	D
MR4	20	20	100	50	0.8	0.8	3.9	2.0
MR5	20	20	120	60	0.8	0.8	4.7	2.4
MR6	20	20	160	80	0.8	0.8	6.3	3.1
MR7	20	20	250	100	0.8	0.8	9.8	3.9
MR8	20	20	300	150	0.8	0.8	11.8	5.9
MR9	20	20	350	200	0.8	0.8	13.8	7.9

* = For a drive with IP54 / UL Type 12, the minimum clearances A and B are 0 mm / 0 in.

Table 14: The necessary quantity of cooling air

Frame	The quantity of cooling air [m ³ /h]	The quantity of cooling air [CFM]
MR4	45	26.5
MR5	75	44.1
MR6	190	111.8
MR7	185	108.9
MR8	335	197.2
MR9	621	365.5

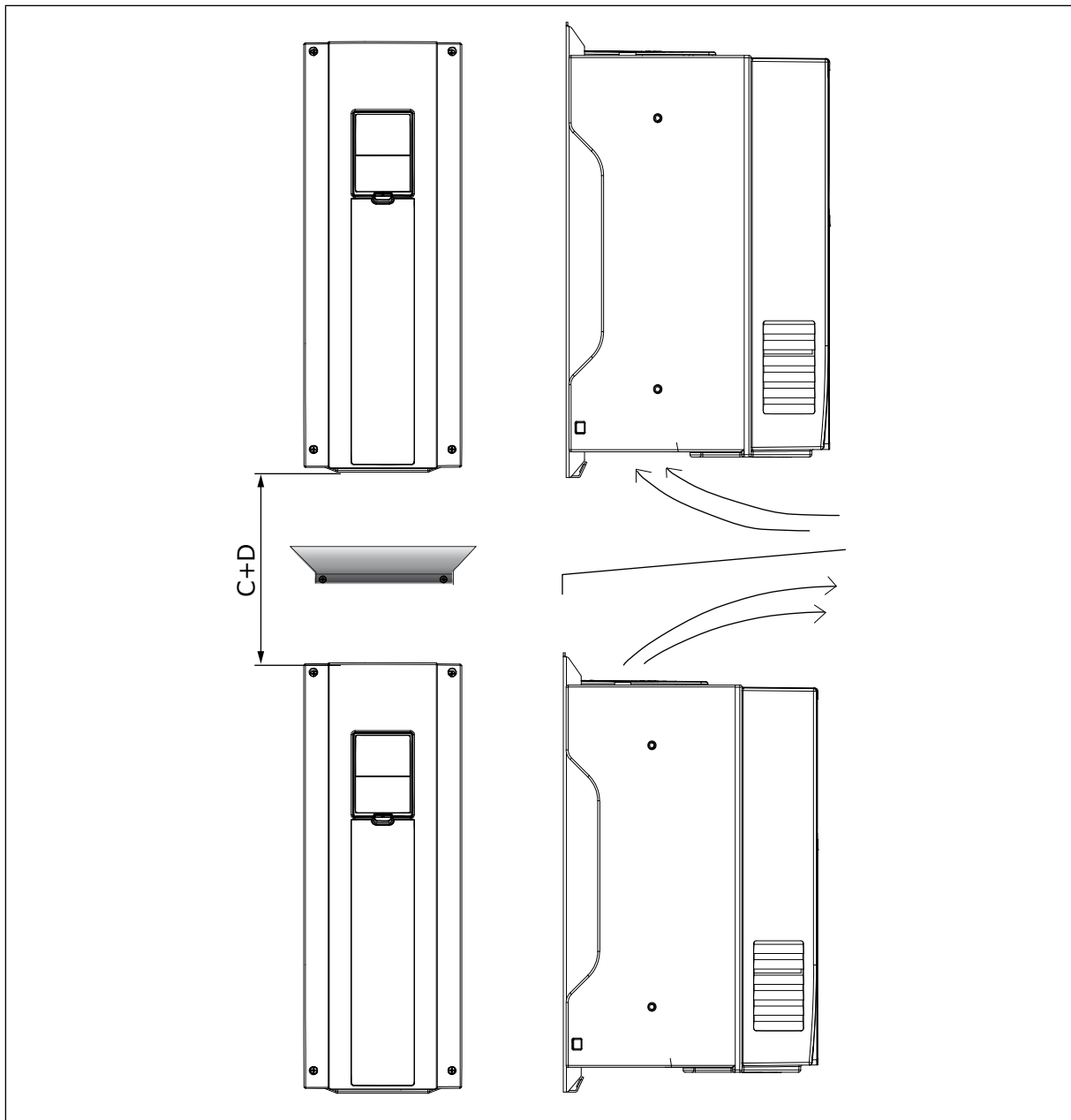

Fig. 34: The installation space when drives are installed on top of each other

If you install many drives above each other

1. The necessary free space is $C + D$.
2. Make the outlet air of the lower unit go away from the air intake of the upper unit. To do this, attach a metal plate to the cabinet wall between the drives.
3. When you install the drives in a cabinet, make sure that you prevent recirculation of air.

5 POWER CABLING

5.1 CABLE CONNECTIONS

The mains cables are connected to terminals L1, L2 and L3. The motor cables are connected to terminals U, V and W.

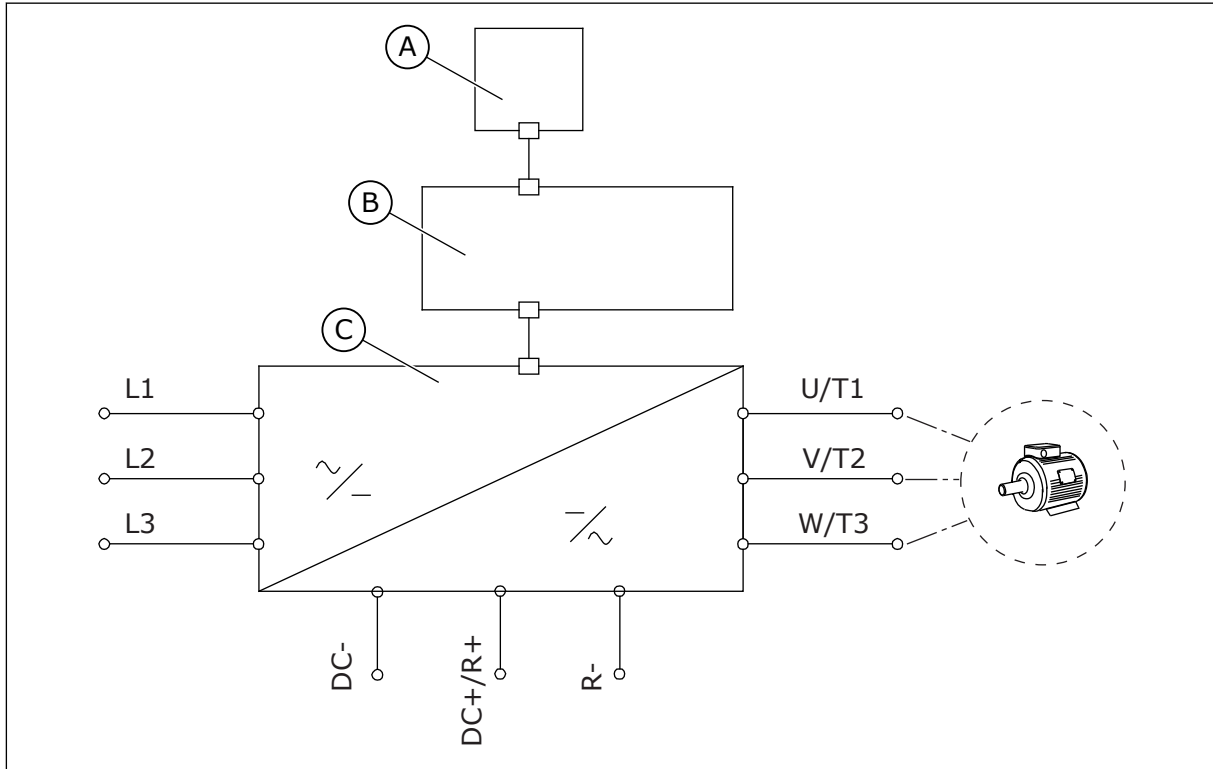

Fig. 35: The principal connection diagram

- A. The control panel
 B. The control unit
 C. The power unit

Use cables with a minimum heat resistance of +70 °C (158 °F). In the selection of the cables and the fuses, refer to the nominal **output** current of the drive. You can find the nominal output current on the nameplate.

Table 15: The selection of the correct cable

Cable type	EMC requirements		
	1st environment	2nd environment	
	Category C2	Category C3	Category C4
The mains cable	1	1	1
The motor cable	3 *	2	2
The control cable	4	4	4

1. A power cable for a fixed installation. A cable for the specified mains voltage. A shielded cable is not necessary. We recommend an MCMK cable.
2. A symmetrical power cable with a concentric protection wire. A cable for the specified mains voltage. We recommend an MCMK cable. See *Fig. 36*.
3. A symmetrical power cable with a compact low-impedance shield. A cable for the specified mains voltage. We recommend an MCCMK, or an EMCMK cable. We recommend that the cable transfer impedance [1...30MHz] is a maximum of 100 mΩ/m. See *Fig. 36*. * = For the EMC level C2, it is necessary to have a 360° grounding of the shield with cable glands in the motor end.
4. A screened cable with a compact low-impedance shield, for example a JAMAK, or an SAB/ÖZCuY-0 cable.

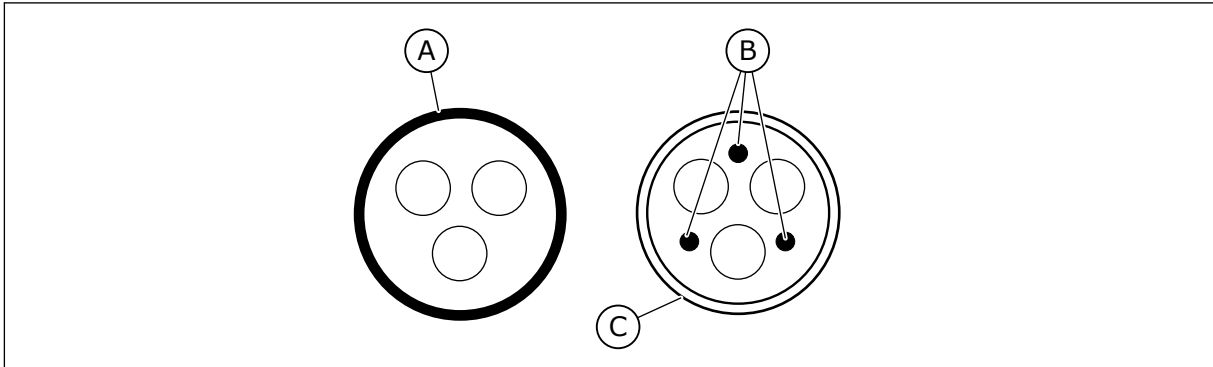

Fig. 36: Cables with PE conductors

- A. The PE conductor and the shield C. The shield
 B. The PE conductors

In all the frames, to obey the EMC requirements, use the default values of the switching frequencies.

If you installed a safety switch, make sure that the EMC protection continues from the start of the cables until their ends.

5.2 UL STANDARDS ON CABLING

To obey the UL (Underwriters Laboratories) regulations, use a UL-approved Class 1 copper wire with a minimum heat resistance of 60 or 75 °C (140 or 167 °F).

You can use the drive on a circuit that gives a maximum of 100 000 rms symmetrical amperes, and a maximum of 600 V, when the drive is protected by Class T and J fuses.

5.3 CABLE DIMENSIONING AND SELECTION

These instructions are valid only for processes that have 1 motor and 1 cable connection from the AC drive to the motor. In other conditions, speak to the manufacturer to get more information.

5.3.1 CABLE AND FUSE SIZES

We recommend the fuse type gG/gL (IEC 60269-1). To make a selection of the fuse voltage rating, refer to the mains. Do not use larger fuses than what is recommended in *Table 16* and *Table 17*.

Make sure that the operation time of the fuse is less than 0.4 seconds. The operation time agrees with the fuse type and the impedance of the supply circuit. For more information on faster fuses, speak to the manufacturer. The manufacturer can also recommend some aR (UL recognised, IEC 60269-4) and gS (IEC 60269-4) fuse ranges.

The table also shows the typical sizes and types of cables that can be used with the AC drive. In the selection of cables, refer to local regulations, cable installation conditions and cable specification.

**NOTE!**

The Vacon® 100 FLOW and HVAC software does not have the dynamic braking or the brake resistor functions.

Table 16: The cable and fuse sizes for Vacon® 100, mains voltage 208-240 V and 380-500 V

Frame	Type	IL [A]	Fuse [gG/gL] [A]	Mains, motor and brake resistor* cable Cu [mm ²]	Terminal cable size	
					Mains cable terminal [mm ²]	Grounding terminal [mm ²]
MR4	0003 2—0004 2 0003 5—0004 5	3.7—4.8 3.4—4.8	6	3x1.5+1.5	1—6 solid 1—4 stranded	1-6
	0006 2—0008 2 0005 5—0008 5	6.6—8.0 5.6—8.0	10	3x1.5+1.5	1—6 solid 1—4 stranded	1-6
	0011 2—0012 2 0009 5—0012 5	11.0—12.5 9.6—12.0	16	3x2.5+2.5	1—6 solid 1—4 stranded	1-6
MR5	0018 2 0016 5	18.0 16.0	20	3x6+6	1—10 Cu	1-10
	0024 2 0023 5	24.0 23.0	25	3x6+6	1—10 Cu	1-10
	0031 2 0031 5	31.0 31.0	32	3x10+10	1—10 Cu	1-10
MR6	0038 5	38.0	40	3x10+10	2.5—50 Cu/Al	2.5-35
	0048 2 0046 5	48.0 46.0	50	3x16+16 (Cu) 3x25+16 (Al)	2.5—50 Cu/Al	2.5-35
	0062 2 0061 5	62.0 61.0	63	3x25+16 (Cu) 3x35+10 (Al)	2.5—50 Cu/Al	2.5-35
MR7	0075 2 0072 5	75.0 72.0	80	3x35+16 (Cu) 3x50+16 (Al)	6-70 mm ² Cu/Al	6-70 mm ²
	0088 2 0087 5	88.0 87.0	100	3x35+16 (Cu) 3x70+21 (Al)	6-70 mm ² Cu/Al	6-70 mm ²
	0105 2 0105 5	105.0	125	3x50+25 (Cu) 3x70+21 (Al)	6-70 mm ² Cu/Al	6-70 mm ²
MR8	0140 2 0140 5	140.0	160	3x70+35 (Cu) 3x95+29 (Al)	Bolt size M8	Bolt size M8
	0170 2 0170 5	170.0	200	3x95+50 (Cu) 3x150+41 (Al)	Bolt size M8	Bolt size M8
	0205 2 0205 5	205.0	250	3x120+70 (Cu) 3x185+57 (Al)	Bolt size M8	Bolt size M8
MR9	0261 2 0261 5	261.0	315	3x185+95 (Cu) 2x3x120+41 (Al)	Bolt size M10	Bolt size M8
	0310 2 0310 5	310.0	350	2x3x95+50 (Cu) 2x3x120+41 (Al)	Bolt size M10	Bolt size M8

* = If you use a multi-conductor cable, 1 of the conductors of the brake resistor cable stays unconnected. It is also possible to use a single cable if you obey the minimum cross-sectional area of the cable.

Table 17: The cable and fuse sizes for Vacon® 100, mains voltage 525-690 V

Frame	Type	IL [A]	Fuse (gG/gL) [A]	Mains, motor and brake resistor* cable Cu [mm ²]	Terminal cable size	
					Mains cable terminal [mm ²]	Grounding terminal [mm ²]
MR5	0004 6	3.9	6	3x1.5+1.5	1 - 10 Cu	1 - 10
	0006 6	6.1	10	3x1.5+1.5	1 - 10 Cu	1 - 10
	0009 6	9.0	10	3x2.5+2.5	1 - 10 Cu	1 - 10
	0011 6	11.0	16	3x2.5+2.5	1 - 10 Cu	1 - 10
MR6	0007 7	7.5	10	3x2.5+2.5	2.5 - 50 Cu/Al	2.5 - 35
	0010 7	10.0	16	3x2.5+2.5	2.5 - 50 Cu/Al	2.5 - 35
	0013 7	13.5	16	3x6+6	2.5 - 50 Cu/Al	2.5 - 35
	0018 6 0018 7	18.0	20	3x10+10	2.5 - 50 Cu/Al	2.5 - 35
	0022 6 0022 7	22.0	25	3x10+10	2.5 - 50 Cu/Al	2.5 - 35
	0027 6 0027 7	27.0	32	3x10+10	2.5 - 50 Cu/Al	2.5 - 35
	0034 6 0034 7	34.0	35	3x16+16	2.5 - 50 Cu/Al	2.5 - 35
MR7	0041 6 0041 7	41.0	50	3x16+16 (Cu) 3x25+16 (Al)	6 - 70 mm ² Cu/Al	6 - 70 mm ²
	0052 6 0052 7	52.0	63	3x25+16 (Cu) 3x35+16 (Al)	6 - 70 mm ² Cu/Al	6 - 70 mm ²
	0062 6 0062 7	62.0	63	3x25+16 (Cu) 3x35+16 (Al)	6 - 70 mm ² Cu/Al	6 - 70 mm ²
MR8	0080 6 0080 7	80.0	80	3x35+16 (Cu) 3x50+21 (Al)	Bolt size M8	Bolt size M8
	0100 6 0100 7	100.0	100	3x50+25 (Cu) 3x70+21 (Al)	Bolt size M8	Bolt size M8
	0125 6 0125 7	125.0	125	3x70+35 (Cu) 3x95+29 (Al)	Bolt size M8	Bolt size M8

Table 17: The cable and fuse sizes for Vacon® 100, mains voltage 525-690 V

Frame	Type	IL [A]	Fuse (gG/gL) [A]	Mains, motor and brake resistor* cable Cu [mm ²]	Terminal cable size	
					Mains cable terminal [mm ²]	Grounding terminal [mm ²]
MR9	0144 6 0144 7	144.0	160	3x70+35 (Cu) 3x120+41 (Al)	Bolt size M10	Bolt size M10
	0170 7	170.0	200	3x95+50 (Cu) 3x150+41 (Al)	Bolt size M10	Bolt size M10
	0208 6 0208 7	208.0	250	3x120+70 (Cu) 3x185+57 (Al)	Bolt size M10	Bolt size M10

* = If you use a multi-conductor cable, 1 of the conductors of the brake resistor cable stays unconnected. It is also possible to use a single cable if you obey the minimum cross-sectional area of the cable.

The dimensions of the cables must agree with the requirements of the standard IEC60364-5-52.

- The cables must be PVC-isolated.
- The maximum ambient temperature is +30 °C.
- The maximum temperature of the cable surface is +70 °C.
- Use only cables with a concentric copper shield.
- The maximum number of parallel cables is 9.

When you use parallel cables, make sure that you obey the requirements of the cross-sectional area and the maximum number of cables.

For important information on the requirements of the grounding conductor, see chapter 2.4 *Grounding and earth fault protection*.

For the correction factors for each temperature, see the standard IEC60364-5-52.

5.3.2 CABLE AND FUSE SIZES, NORTH AMERICA

We recommend the fuse class T (UL & CSA). To make a selection of the fuse voltage rating, refer to the mains. Refer also to local regulations, cable installation conditions and cable specification. Do not use larger fuses than what is recommended in *Table 18* and *Table 19*.

Make sure that the operation time of the fuse is less than 0.4 seconds. The operation time agrees with the fuse type and the impedance of the supply circuit. For more information on faster fuses, speak to the manufacturer. The manufacturer can also recommend some high speed Class J (UL & CSA) and aR (UL recognised) fuse ranges.

The solid state short circuit protection does not supply protection for the branch circuit of the AC drive. To supply the branch circuit protection, refer to the National Electric Code and the local regulations. Do not use other devices than fuses to supply branch circuit protection.

**NOTE!**

The Vacon® 100 FLOW and HVAC software do not have the dynamic braking or the brake resistor functions.

Table 18: The cable and fuse sizes for Vacon® 100 in North America, mains voltage 208-240 V and 380-500 V

Frame	Type	IL [A]	Fuse (Class T/J) [A]	Mains, motor and brake resistor* cable Cu [AWG]	Terminal cable size	
					Mains cable terminal [AWG]	Grounding terminal [AWG]
MR4	0003 2 0003 5	3.7 3.4	6	14	24-10	17-10
	0004 2 0004 5	4.8	6	14	24-10	17-10
	0006 2 0005 5	6.6 5.6	10	14	24-10	17-10
	0008 2 0008 5	8.0	10	14	24-10	17-10
	0011 2 0009 5	11.0 9.6	15	14	24-10	17-10
	0012 2 0012 5	12.5 12.0	20	14	24-10	17-10
MR5	0018 2 0016 5	18.0 16.0	25	10	20-5	17-8
	0024 2 0023 5	24.0 23.0	30	10	20-5	17-8
	0031 2 0031 5	31.0	40	8	20-5	17-8
MR6	0038 5	38.0	50	4	13-0	13-2
	0048 2 0046 5	48.0 46.0	60	4	13-0	13-2
	0062 2 0061 5 **	62.0 61.0	80	4	13-0	13-2
MR7	0075 2 0072 5	75.0 72.0	100	2	9-2/0	9-2/0
	0088 2 0087 5	88.0 87.0	110	1	9-2/0	9-2/0
	0105 2 0105 5	105.0	150	1/0	9-2/0	9-2/0

Table 18: The cable and fuse sizes for Vacon® 100 in North America, mains voltage 208-240 V and 380-500 V

Frame	Type	IL [A]	Fuse (Class T/J) [A]	Mains, motor and brake resistor* cable Cu [AWG]	Terminal cable size	
					Mains cable terminal [AWG]	Grounding terminal [AWG]
MR8	0140 2 0140 5	140.0	200	3/0	1 AWG-350 kcmil	1 AWG-350 kcmil
	0170 2 0170 5	170.0	225	250 kcmil	1 AWG-350 kcmil	1 AWG-350 kcmil
	0205 2 0205 5	205.0	250	350 kcmil	1 AWG-350 kcmil	1 AWG-350 kcmil
MR9	0261 2 0261 5	261.0	350	2x250 kcmil	1 AWG-350 kcmil	1 AWG-350 kcmil
	0310 2 0310 5	310.0	400	2x350 kcmil	1 AWG-350 kcmil	1 AWG-350 kcmil

* = If you use a multi-conductor cable, 1 of the conductors of the brake resistor cable stays unconnected. It is also possible to use a single cable if you obey the minimum crosssectional area of the cable.

** = To obey the UL regulations with the 500 V drive, it is necessary to have cables with a +194 °F heat resistance.

Table 19: The cable and fuse sizes for Vacon® 100 in North America, mains voltage 525-690 V

Frame	Type	IL [A]	Fuse (Class T/J) [A]	Mains, motor and brake resistor* cable Cu [AWG]	Terminal cable size	
					Mains cable terminal [AWG]	Grounding terminal [AWG]
MR5 (600 V)	0004 6	3.9	6	14	20-5	17-8
	0006 6	6.1	10	14	20-5	17-8
	0009 6	9.0	10	14	20-5	17-8
	0011 6	11.0	15	14	20-5	17-8
MR6	0007 7	7.5	10	12	13-0	13-2
	0010 7	10.0	15	12	13-0	13-2
	0013 7	13.5	20	12	13-0	13-2
	0018 6 0018 7	18.0	20	10	13-0	13-2
	0022 6 0022 7	22.0	25	10	13-0	13-2
	0027 6 0027 7	27.0	30	8	13-0	13-2
	0034 6 0034 7	34.0	40	8	13-0	13-2
MR7	0041 6 0041 7	41.0	50	6	9-2/0	9-2/0
	0052 6 0052 7	52.0	60	6	9-2/0	9-2/0
	0062 6 0062 7	62.0	70	4	9-2/0	9-2/0
MR8	0080 6 0080 7	80.0	90	1/0	1 AWG-350 kcmil	1 AWG-350 kcmil
	0100 6 0100 7	100.0	110	1/0	1 AWG-350 kcmil	1 AWG-350 kcmil
	0125 6 0125 7	125.0	150	2/0	1 AWG-350 kcmil	1 AWG-350 kcmil

Table 19: The cable and fuse sizes for Vacon® 100 in North America, mains voltage 525-690 V

Frame	Type	IL [A]	Fuse (Class T/J) [A]	Mains, motor and brake resistor* cable Cu [AWG]	Terminal cable size	
					Mains cable terminal [AWG]	Grounding terminal [AWG]
MR9	0144 6 0144 7	144.0	175	3/0	1 AWG-350 kcmil	1 AWG-350 kcmil
	0170 7	170.0	200	4/0	1 AWG-350 kcmil	1 AWG-350 kcmil
	0208 6 0208 7	208.0	250	300 kcmil	1 AWG-350 kcmil	1 AWG-350 kcmil

* = If you use a multi-conductor cable, 1 of the conductors of the brake resistor cable stays unconnected. It is also possible to use a single cable if you obey the minimum crosssectional area of the cable.

The dimensions of the cables must agree with the requirements of the Underwriters Laboratories UL 61800-5-1.

- The cables must be PVC-isolated.
- The maximum ambient temperature is +86 °F.
- The maximum temperature of the cable surface is +158 °F.
- Use only cables with a concentric copper shield.
- The maximum number of parallel cables is 9.

When you use parallel cables, make sure that you obey the requirements of the cross-sectional area and the maximum number of cables.

For important information on the requirements of the grounding conductor, see the Underwriters Laboratories standard UL 61800-5-1.

For the correction factors for each temperature, see the instructions of the Underwriters Laboratories UL 61800-5-1.

5.4 BRAKE RESISTOR CABLES

Vacon® 100 AC drives have terminals for an optional external brake resistor. These terminals are identified with R+ and R- (in MR4 and MR5) or DC+/R+ and R- (in MR6, MR7, MR8 and MR9). You can find the dimensions that we recommend for the brake resistor cables in the tables in chapters 5.3.1 *Cable and fuse sizes* and 5.3.2 *Cable and fuse sizes, North America*.



CAUTION!

If you use a multi-conductor cable, 1 of the conductors of the brake resistor cable stays unconnected. Cut off the remaining conductor to prevent an accidental contact with a conducting component.

See the brake resistor ratings in chapter 8.1.6 *Brake resistor ratings*.

**NOTE!**

The frames MR7, MR8, and MR9 have the brake chopper, only if their type designation code has the code +DBIN. The frames MR4, MR5, and MR6 have the brake chopper as standard.

**NOTE!**

The Vacon® 100 FLOW and HVAC software do not have the dynamic braking or the brake resistor functions.

5.5 PREPARING FOR THE CABLE INSTALLATION

- Before you start, make sure that none of the components of the AC drive is live. Read carefully the warnings in chapter 2 *Safety*.
- Make sure that the motor cables are sufficiently far from other cables.
- The motor cables must cross other cables at an angle of 90°.
- If it is possible, do not put the motor cables in long parallel lines with other cables.
- If the motor cables are in parallel with other cables, obey the minimum distances (see *Table 20 The minimum distances between cables*).
- The distances are also valid between the motor cables and the signal cables of other systems.
- The maximum lengths of shielded motor cables are 100 m / 328 ft (for MR4), 150 m / 492 ft (for MR5 and MR6), and 200 m / 656 ft (for MR7, MR8, and MR9).
- If the cable insulation checks are necessary, see chapter 7.4 *Measuring the cable and motor insulation* for instructions.

Table 20: The minimum distances between cables

The distance between cables [m]	The length of the shielded cable [m]	The distance between cables [ft]	The length of the shielded cable [ft]
0.3	≤ 50	1.0	≤ 164.0
1.0	≤ 200	3.3	≤ 656.1

5.6 CABLE INSTALLATION

5.6.1 FRAMES MR4 TO MR7

Table 21: The cable stripping lengths [mm]. See the figure in step 1.

Frame	A	B	C	D	E	F	G
MR4	15	35	10	20	7	35	*
MR5	20	40	10	30	10	40	*
MR6	20	90	15	60	15	60	*
MR7	20	80	20	80	20	80	*

* = As short as possible.

Table 22: The cable stripping lengths [in]. See the figure in step 1.

Frame	A	B	C	D	E	F	G
MR4	0.6	1.4	0.4	0.8	0.3	1.4	*
MR5	0.8	1.6	0.4	1.2	0.4	1.6	*
MR6	0.8	3.6	0.6	2.4	0.6	2.4	*
MR7	0.8	3.1	0.8	3.1	0.8	3.1	*

* = As short as possible.

- Strip the motor cable, the mains cable, and the brake resistor cable.



NOTE!

The Vacon® 100 FLOW and HVAC software do not have the dynamic braking or the brake resistor functions.

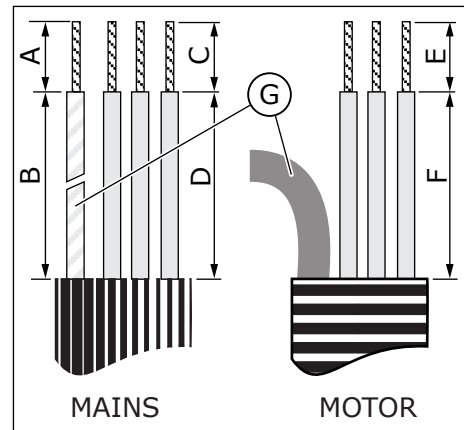

G. The grounding conductor

- Open the cover of the AC drive.

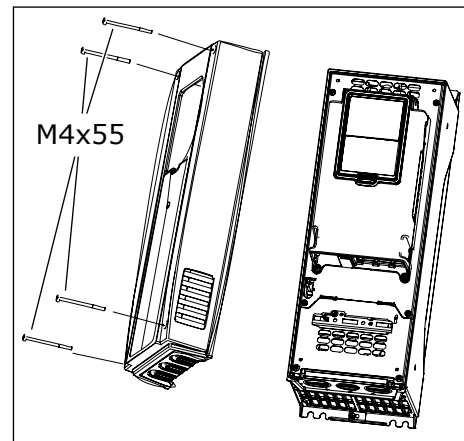

- 3 Remove the screws of the cable cover. Remove the cable cover. Do not open the cover of the power unit.

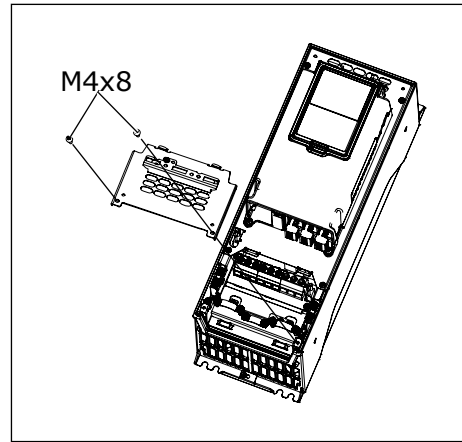

- 4 Put the grommets in the openings of the cable entry plate. These parts are included in the package. The picture shows the grommets in IP21 in the EU version.

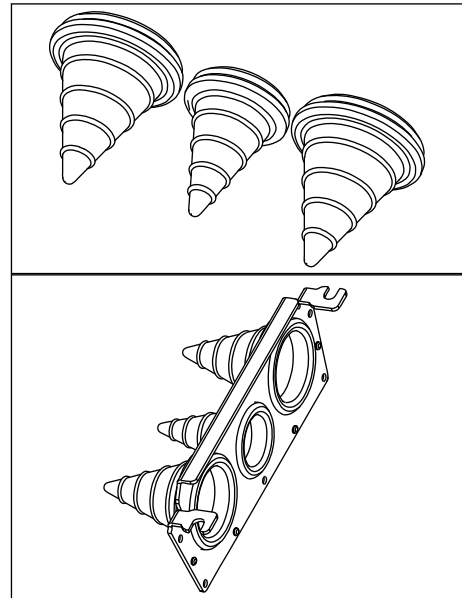

- 5 Put the cables - the mains cable, the motor cable and the optional brake cable - in the openings of the cable entry plate.
 - a) Cut the grommets open to move the cables through them. If the grommets fold in when you put the cable, pull the cable back to make the grommets straight.
 - b) Do not cut the grommet openings wider than what is necessary for the cables that you use.
 - c) With the enclosure class IP54, the connection between the grommet and the cable must be tight. Pull the first bit of the cable out of the grommet so that it stays straight. If this is not possible, make the connection tight with some insulation tape or a cable tie.

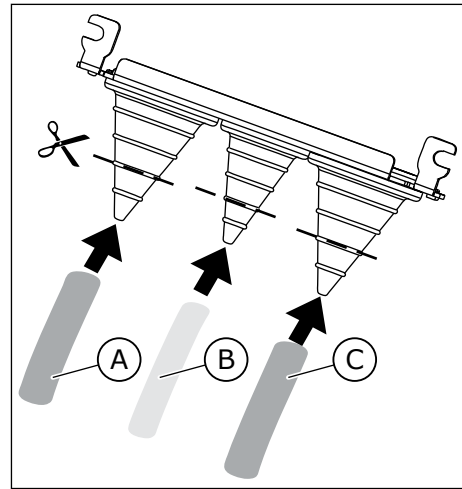

- A. The mains cable
- B. The brake cable
- C. The motor cable

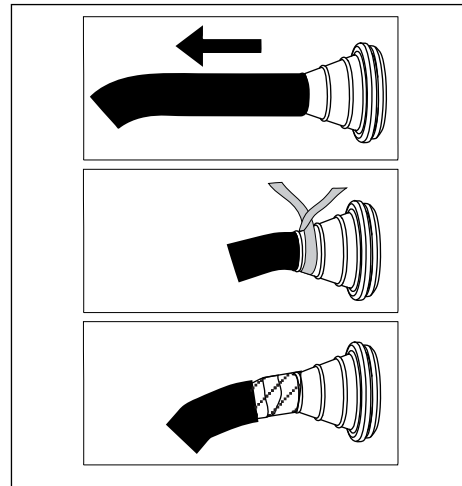

- 6 Remove the grounding clamps for cable shield and the grounding clamps for grounding conductor. The tightening torque is 2.2 Nm or 19.5 lb-in.

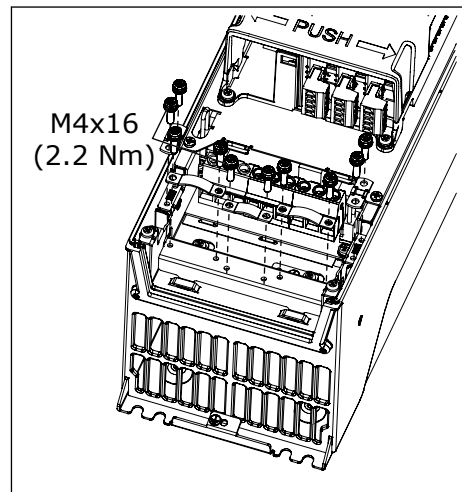

- 7 Put the cable entry plate with the cables into the groove on the frame of the drive.

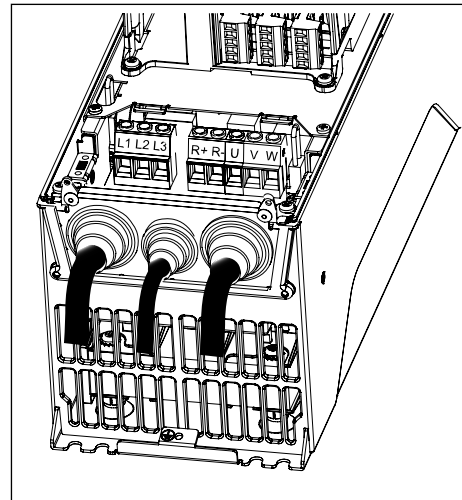

- 8 Connect the stripped cables.

- a) Expose the shield of all the 3 cables to make a 360-degree connection with the grounding clamps for cable shield.
- b) Connect the phase conductors of the mains cable and of the motor cable, and the conductors of the the brake resistor cable into the correct terminals.
- c) Attach the grounding conductor of each cable to a grounding terminal with a grounding clamp for grounding conductor.
- d) Make sure that the external grounding conductor is connected to the grounding bar. See chapter 2.4 *Grounding and earth fault protection*.
- e) See the correct tightening torques in *Table 23*.

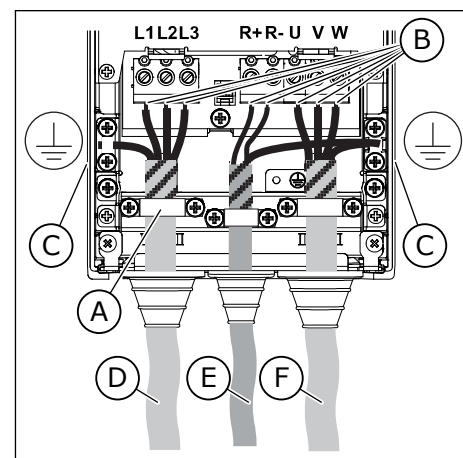

- A. The grounding clamp for cable shield
- B. The terminals
- C. The grounding terminal
- D. The mains cable
- E. The brake resistor cable
- F. The motor cable

- 9 Make sure that the grounding conductor is connected to the motor and also to the terminals that are identified with ⊕.
- a) To obey the requirements of the standard EN 61800-5-1, obey the instructions in chapter 2.4 *Grounding and earth fault protection*.
 - b) If a double grounding is necessary, use the grounding terminal under the drive. Use an M5 screw and tighten it to 2.0 Nm or 17.7 lb-in.

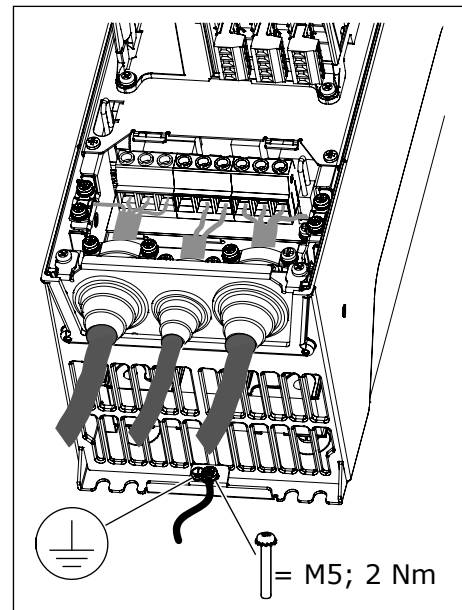

- 10 Attach again the cable cover and the cover of the drive.

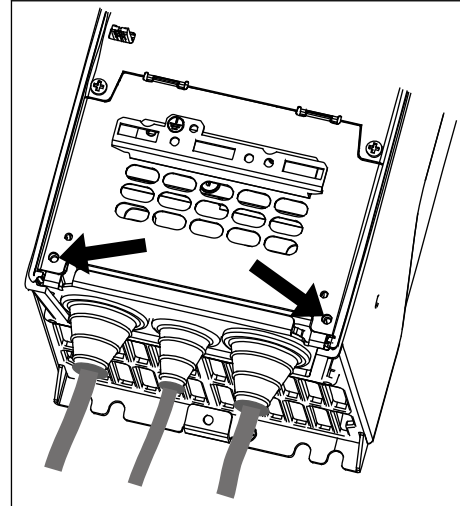
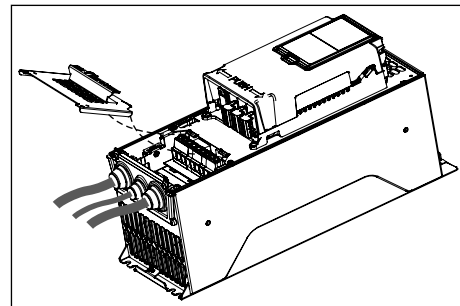

Table 23: The tightening torques of the terminals

Frame	Type	Tightening torque: the mains cable and motor cable terminals		Tightening torque: the grounding clamps for cable shield		Tightening torque: the grounding clamps for grounding conductor	
		Nm	lb-in.	Nm	lb-in.	Nm	lb-in.
MR4	0003 2 - 0012 2 0003 5 - 0012 5	0.5-0.6	4.5-5.3	1.5	13.3	2.0	17.7
MR5	0018 2 - 0031 2 0016 5 - 0031 5 0004 6 - 0011 6	1.2-1.5	10.6-13.3	1.5	13.3	2.0	17.7
MR6	0048 2 - 0062 2 0038 5 - 0061 5 0018 6 - 0034 6 0007 7 - 0034 7	10	88.5	1.5	13.3	2.0	17.7
MR7	0075 2 - 0105 2 0072 5 - 0105 5 0041 6 - 0062 6 0041 7 - 0062 7	8 * / 5.6 **	70.8 * / 49.6 **	1.5	13.3	8 * / 5.6 **	70.8 * / 49.6 **

* = The tightening torque for a torx screw.

** = The tightening torque for an Allen screw.

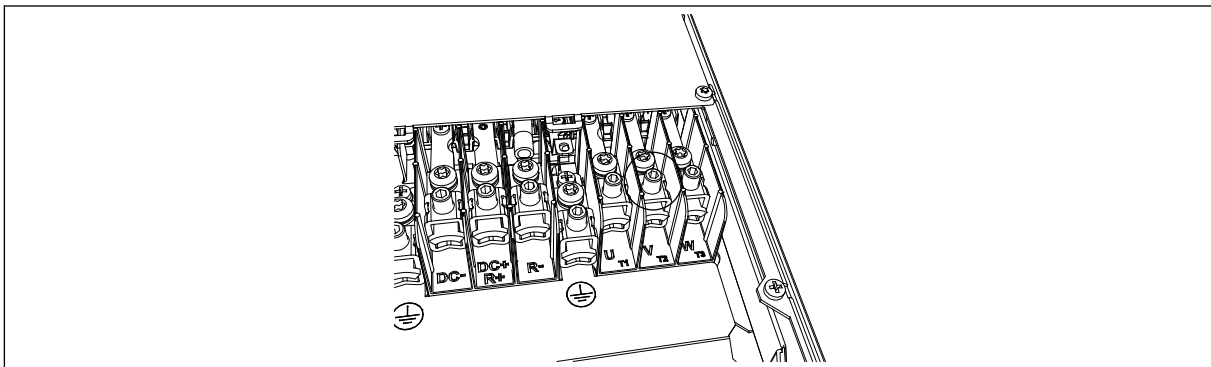

Fig. 37: The tightening torque for the Allen screw in MR7 is 5.6 Nm

5.6.2 FRAMES MR8 TO MR9

Table 24: The cable stripping lengths [mm]. See the figure in step 1.

Frame	A	B	C	D	E	F	G
MR8	40	180	25	300	25	300	*
MR9	40	180	25	300	25	300	*

* = As short as possible.

Table 25: The cable stripping lengths [in]. See the figure in step 1.

Frame	A	B	C	D	E	F	G
MR8	1.6	7.1	1	11.8	1	11.8	*
MR9	1.6	7.1	1	11.8	1	11.8	*

* = As short as possible.

- Strip the motor cable, the mains cable, and the brake resistor cable.



NOTE!

The Vacon® 100 FLOW and HVAC software do not have the dynamic braking or the brake resistor functions.

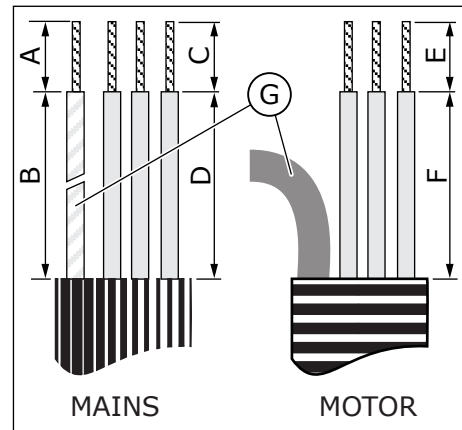

G. The grounding conductor

2 MR9 only: Open the cover of the AC drive.

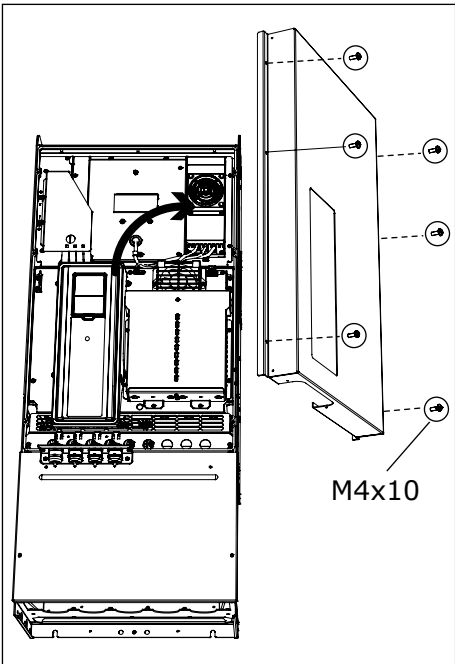

- 3 Remove the cable cover.

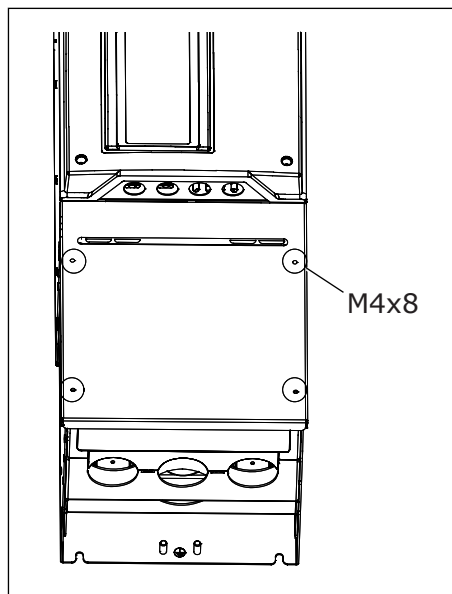

MR8

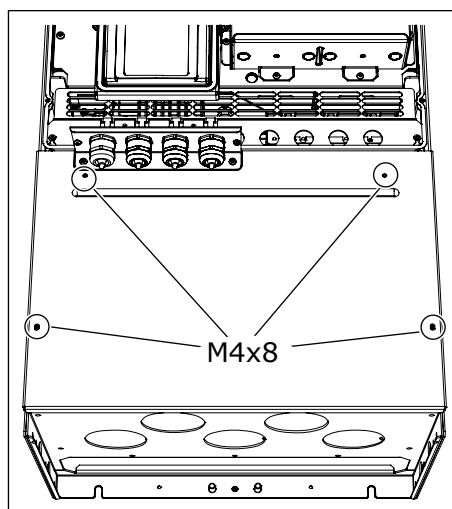

MR9

- 4 Remove the cable entry plate.

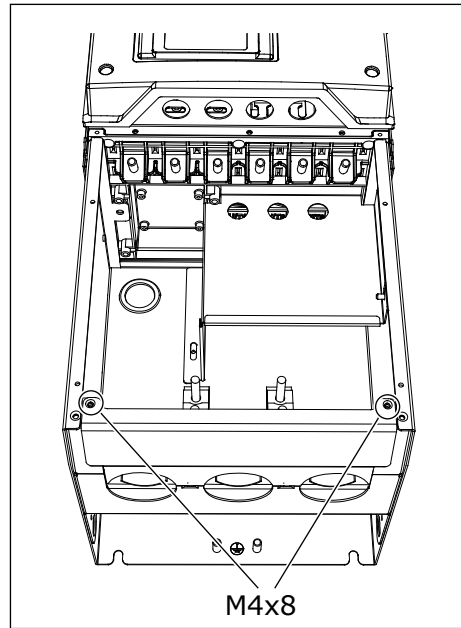

MR8

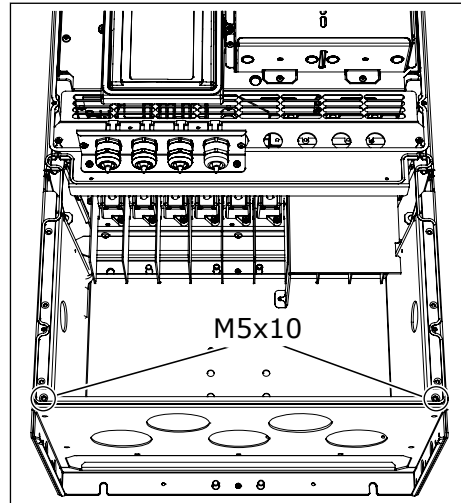

MR9

- 5 MR9 only: Loosen the screws and remove the sealing plate.

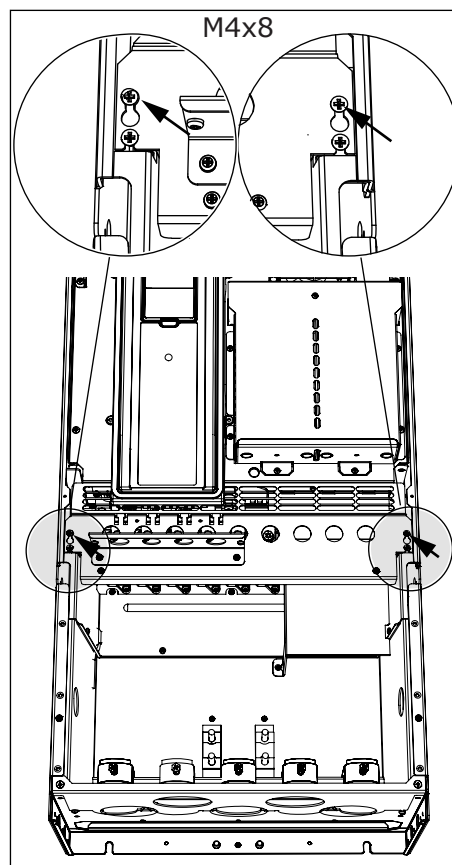

6 Remove the EMC shield plate.

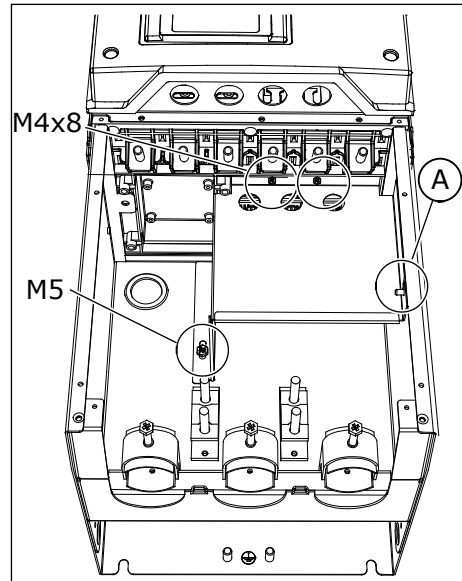

A. The wing nut in MR8

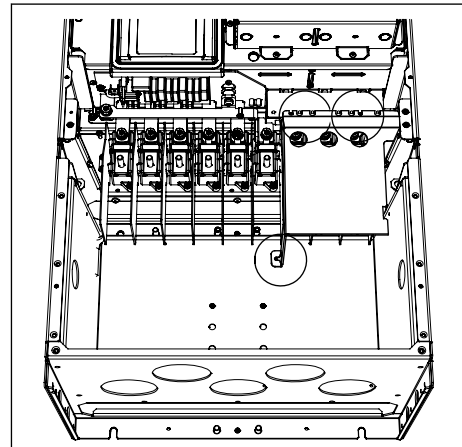

MR9

- 7 Find the motor cable terminals. The location of the terminals is different than usually, especially in MR8.

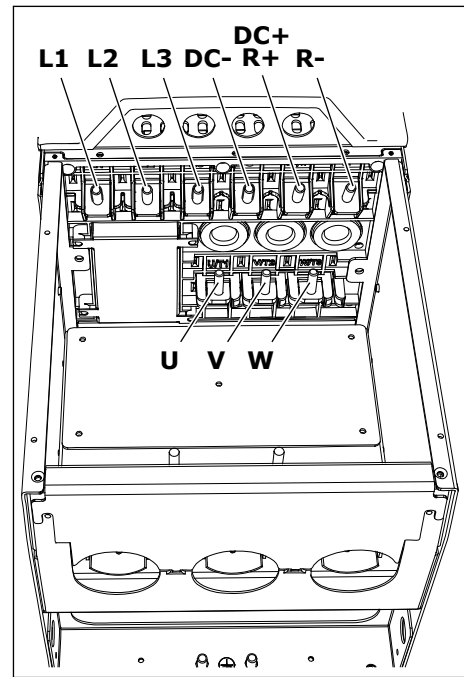

MR8

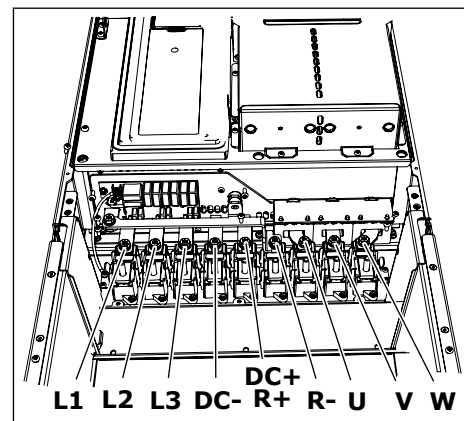

MR9

- 8 Cut the grommets open to move the cables through them.
- Do not cut the grommet openings wider than what is necessary for the cables that you use.
 - If the grommets fold in when you put the cable, pull the cable back to make the grommets straight.

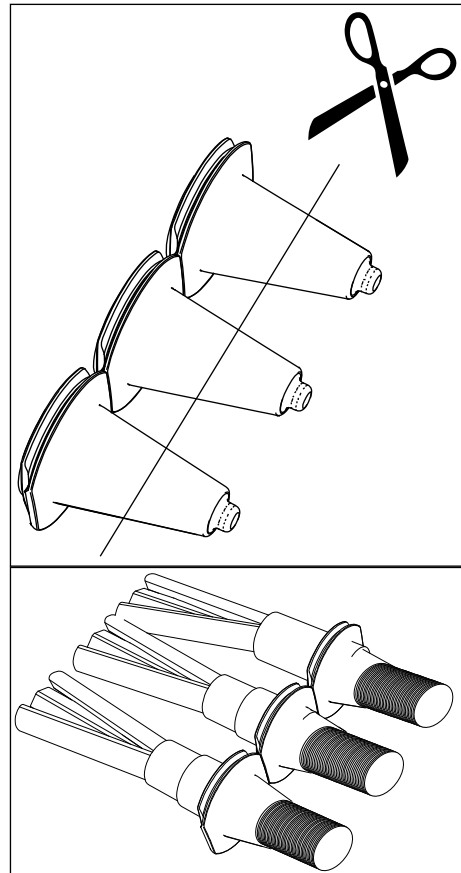

- 9 Attach the grommet and the cable so that the frame of the drive goes into the groove of the grommet.
- With the enclosure class IP54, the connection between the grommet and the cable must be tight. Pull the first bit of the cable out of the grommet so that it stays straight.
 - If this is not possible, make the connection tight with some insulation tape or a cable tie.

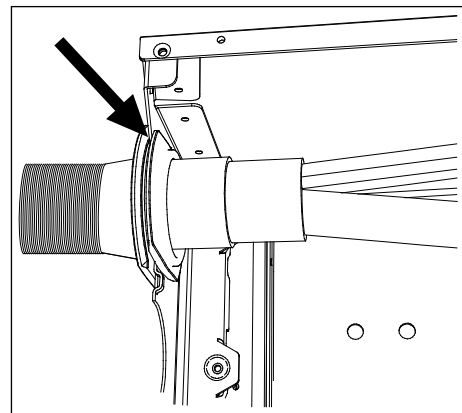

- 10 If you use thick cables, put the cable insulators in between the terminals to prevent contact between the cables.

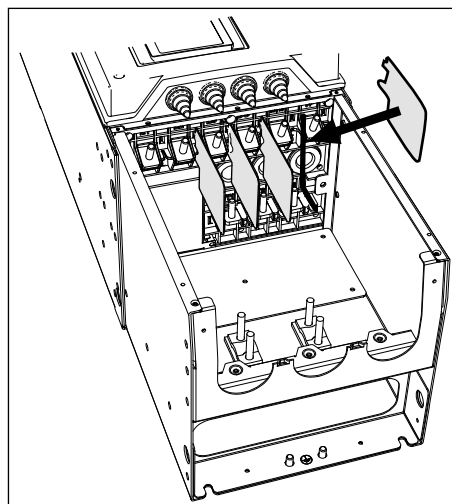

11 Connect the stripped cables.

- a) Connect the phase conductors of the mains cable and of the motor cable into the correct terminals. If you use a brake resistor cable, connect its conductors into the correct terminals.
- b) Attach the grounding conductor of each cable to a grounding terminal with a grounding clamp for grounding conductor.
- c) Make sure that the external grounding conductor is connected to the grounding bar. See chapter 2.4 *Grounding and earth fault protection*.
- d) See the correct tightening torques in *Table 26*.

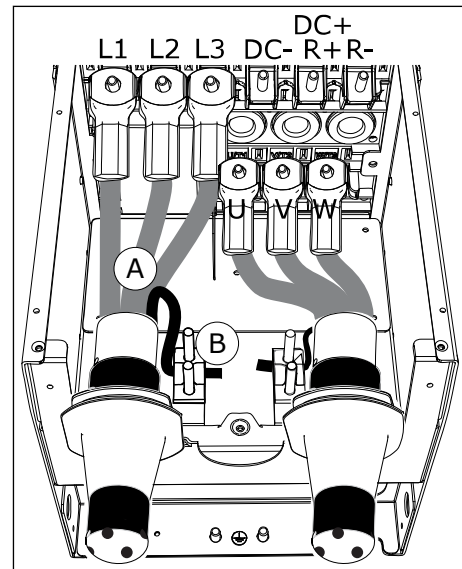

- A. Connection of the cables
- B. Make a grounding connection in MR8

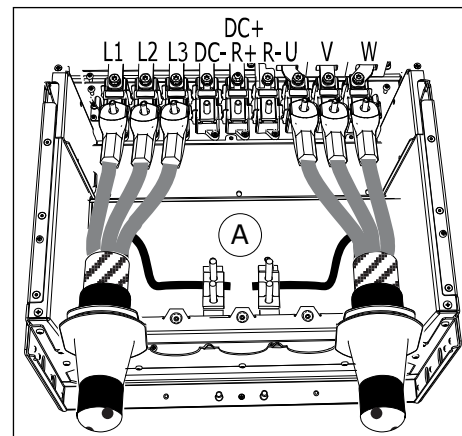

- A. Make a grounding connection in MR9

- 12 If you use many cables on one connector, put the cable lugs on top of each other.

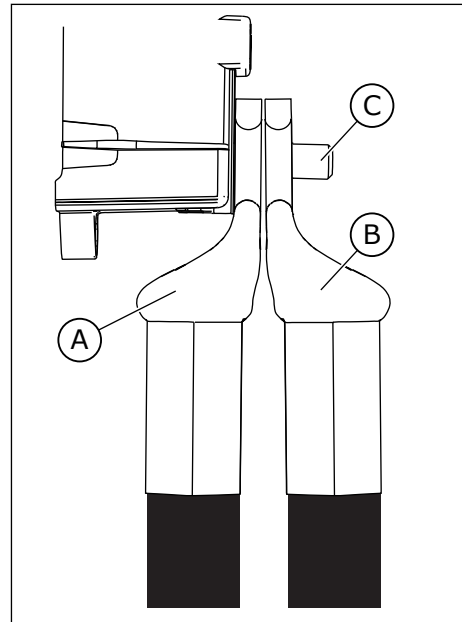

- A. The first cable lug
 B. The second cable lug
 C. The connector

- 13 Expose the shield of all 3 cables to make a 360-degree connection with the grounding clamp for cable shield.

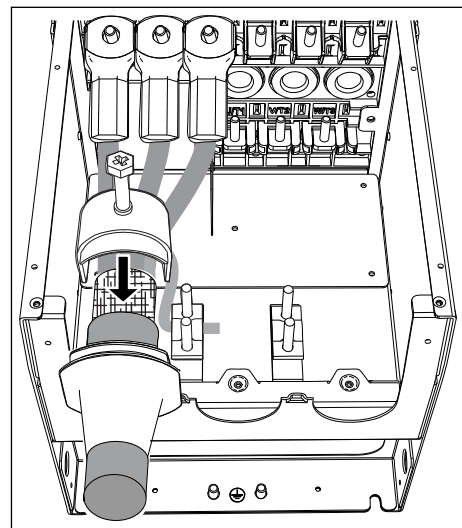

- 14 Attach again the EMC shield plate. For MR9, attach the sealing plate.

- 15 Attach the cable entry plate, and then the cable cover.

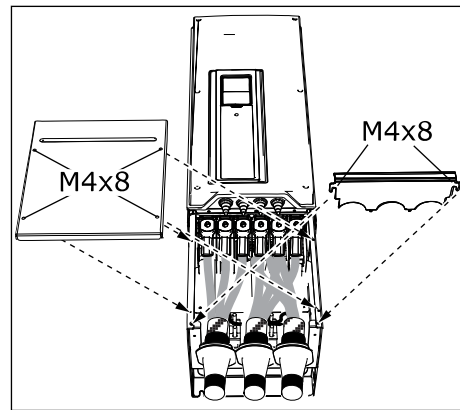

- 16 For MR9, attach the cover of the drive (unless you want to make the control connections first).

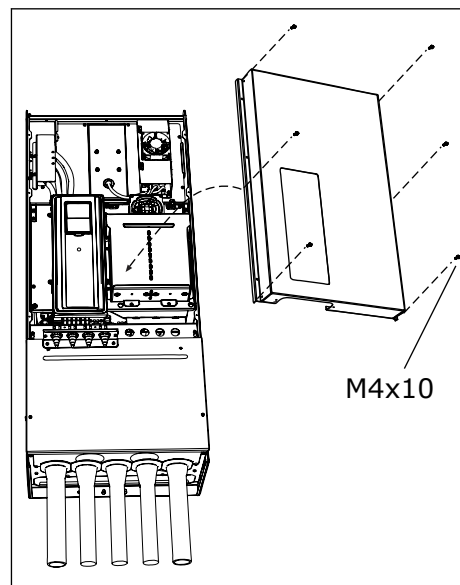

- 17 Make sure that the grounding conductor is connected to the motor and also to the terminals that are identified with ⊕.
- To obey the requirements of the standard EN 61800-5-1, obey the instructions in chapter 2.4 *Grounding and earth fault protection*.
 - Connect the protective conductor to 1 of the screw connectors with a cable shoe and an M8 screw.

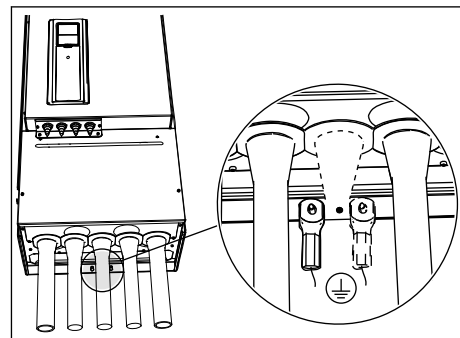

Table 26: Tightening torques of the terminals

Frame	Type	Tightening torque: the mains cable and motor cable terminals		Tightening torque: the grounding clamps for cable shield		Tightening torque: the grounding clamps for grounding conductor	
		[Nm]	lb-in.	[Nm]	lb-in.	[Nm]	lb-in.
MR8	0140 2 - 0205 2 0140 5 - 0205 5 0080 6 - 0125 6 0080 7 - 0125 7	30	266	1.5	13.3	20	177
MR9	0261 2 - 0310 2 0261 5 - 0310 5 0144 6 - 0208 6 0144 7 - 0208 7	40	266	1.5	13.3	20	177

5.7 INSTALLATION IN A CORNER-GROUNDED NETWORK

You can use corner grounding with the drive types (MR7 to MR9) with a rating of 72-310 A with a 380-480 V mains, and 75-310 A with a 208-240 V mains.

In these conditions, you must change the EMC protection level to C4. See the instructions in *7.6 Installation in an IT system*.

Do not use corner grounding with the drive types (MR4 to MR6) with a rating of 3.4-61 A with a 380-480 V mains, or 3.7-62 A with a 208-240 V mains.

Corner grounding is allowed for the MR4-6 drives (main voltage 208-230 V) up to 2000 m.

6 CONTROL UNIT

6.1 CONTROL UNIT COMPONENTS

The control unit of the AC drive contains the standard boards and the option boards. The option boards are connected to the slots of the control board (see 6.4 *Installation of option boards*).

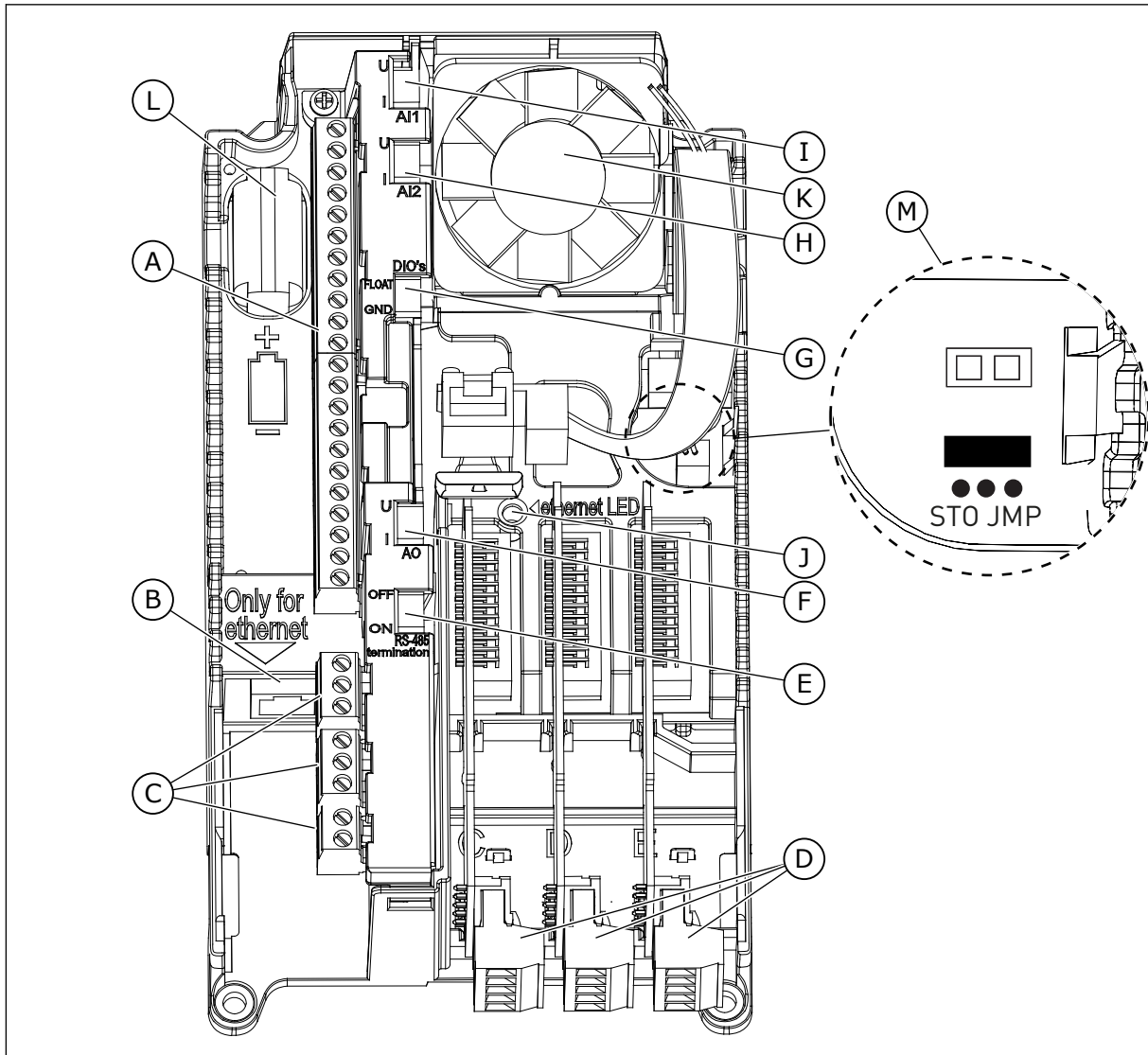

Fig. 38: The components of the control unit

- | | |
|--|--|
| <p>A. The control terminals for the standard I/O connections</p> <p>B. The Ethernet connection</p> <p>C. The relay board terminals for 3 relay outputs or 2 relay outputs and a thermistor</p> <p>D. The option boards</p> | <p>E. A DIP switch for the RS485 bus termination</p> <p>F. A DIP switch for the signal selection of Analogue Output</p> <p>G. A DIP switch for the isolation of the digital inputs from ground</p> <p>H. A DIP switch for the signal selection of Analogue Input 2</p> |
|--|--|

- I. A DIP switch for the signal selection of Analogue Input 1
- J. The status indicator of the Ethernet connection
- K. A fan (only in IP54 of MR4 and of MR5)
- L. The battery for the RTC
- M. The location and the default position of the Safe Torque Off (STO) jumper

When you receive the AC drive, the control unit contains the standard control interface. If you included special options in your order, the AC drive will be as in your order. On the next pages, you will find information on the terminals and general wiring examples.

It is possible to use the drive with an external power source with these properties: +24 VDC $\pm 10\%$, minimum 1000 mA. Connect the external power source to terminal 30. This voltage is sufficient to keep the control unit on and for you to set the parameters. The measurements of the main circuit (for example, the DC link voltage, and the unit temperature) are not available when the drive is not connected to mains.

The status LED of the drive shows the status of the drive. The status LED is located in the control panel, below the keypad, and it can show 5 different statuses.

Table 27: The statuses of the status LED of the drive

Colour of the LED light	Status of the drive
Blinking slowly	Ready
Green	Run
Red	Fault
Orange	Alarm
Blinking fast	Downloading software

6.2 CONTROL UNIT CABLING

The standard I/O board has 22 fixed control terminals and 8 relay board terminals. You can see the standard connections of the control unit and the descriptions of signals in *Fig. 39*.

6.2.1 SELECTION OF THE CONTROL CABLES

The control cables must be a minimum of 0.5 mm² screened multicore cables. See more on the cable types in *Table 15 The selection of the correct cable*. The terminal wires must be a maximum of 2.5 mm² for the relay board terminals and other terminals.

Table 28: The tightening torques of the control cables

The terminal	The terminal screw	The tightening torque	
		Nm	lb-in.
All the terminals of the I/O board and the relay board	M3	0.5	4.5

6.2.2 CONTROL TERMINALS AND DIP SWITCHES

Here you see the basic description of the terminals of the standard I/O board and the relay board. For more information, see *11.1 Technical data on control connections*.

Some terminals are assigned for signals that have optional functions that you can use with the DIP switches. See more in *6.2.2.1 Selection of terminal functions with DIP switches*.

		Standard I/O board																		
		Terminal	Signal	Description																
Reference potentiometer 1...10kΩ	2-wire transmitter	1	+10 Vref	Reference output																
		2	AI1+	Analogue input, voltage or current	Frequency reference															
Actual value I = (0)4...20mA	3	AI1-	Analogue input common, (current)																	
	4	AI2+	Analogue input, voltage or current	Frequency reference																
	5	AI2-	Analogue input common, (current)																	
		6	24Vout	24V auxiliary voltage																
		7	GND	I/O ground																
		8	DI1	Digital input 1	Start forward															
		9	DI2	Digital input 2	Start reverse															
		10	DI3	Digital input 3	External fault															
		11	CM	Common for DI1-DI6	*)															
		12	24Vout	24V auxiliary voltage																
		13	GND	I/O ground																
		14	DI4	Digital input 4	<table border="1"> <tr> <td>DI4</td> <td>DI5</td> <td>Freq. ref.</td> </tr> <tr> <td>Open</td> <td>Open</td> <td>Analog input 1</td> </tr> <tr> <td>Closed</td> <td>Open</td> <td>Preset Freq. 1</td> </tr> <tr> <td>Open</td> <td>Closed</td> <td>Preset Freq. 2</td> </tr> <tr> <td>Closed</td> <td>Closed</td> <td>Preset Freq. 3</td> </tr> </table>	DI4	DI5	Freq. ref.	Open	Open	Analog input 1	Closed	Open	Preset Freq. 1	Open	Closed	Preset Freq. 2	Closed	Closed	Preset Freq. 3
DI4	DI5	Freq. ref.																		
Open	Open	Analog input 1																		
Closed	Open	Preset Freq. 1																		
Open	Closed	Preset Freq. 2																		
Closed	Closed	Preset Freq. 3																		
		15	DI5	Digital input 5																
		16	DI6	Digital input 6	Fault reset															
		17	CM	Common for DI1-DI6	*)															
		18	AO1+	Analogue signal (+output)	Output frequency															
		19	AO1-/GND	Analogue output common / I/O ground																
		30	+24Vin	24V auxiliary input voltage																
		A	RS485	Serial bus, negative	Modbus RTU BACnet, N2															
		B	RS485	Serial bus, positive																
		21	RO1 NC	Relay output 1	RUN															
		22	RO1 CM																	
		23	RO1 NO																	
		24	RO2 NC	Relay output 2	FAULT															
		25	RO2 CM																	
		26	RO2 NO																	
		32	RO3 CM	Relay output 3	READY															
		33	RO3 NO																	

Fig. 39: The signals of the control terminals on the standard I/O board, and a connection example. If you include the optional code +SBF4 in your order, the relay output 3 is replaced with a thermistor input.

* = You can isolate digital inputs from ground with a DIP switch. See 6.2.2.2 *Isolation of digital inputs from ground*.

There are 2 different relay boards available.

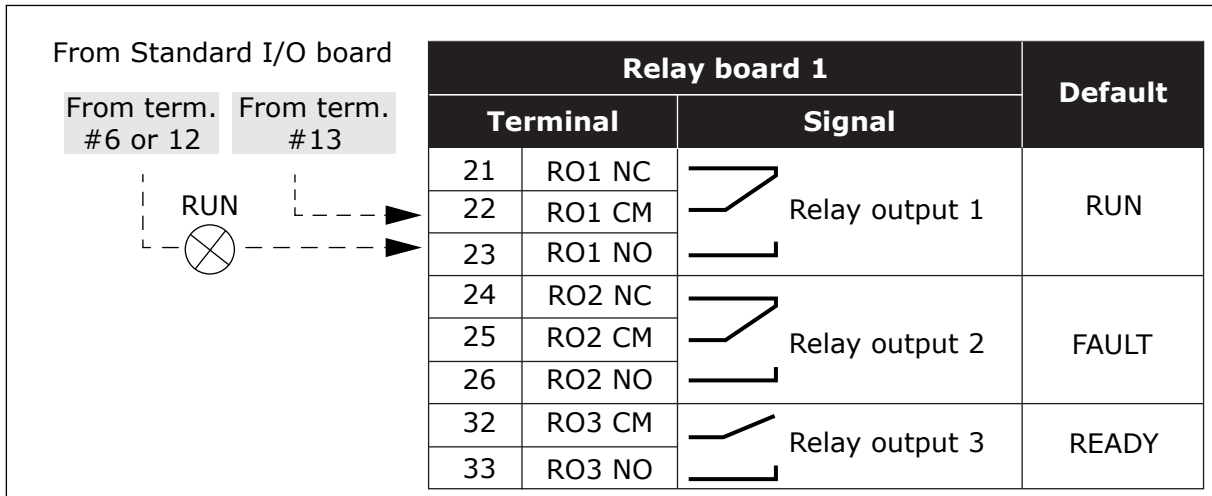

Fig. 40: The standard relay board (+SBF3)

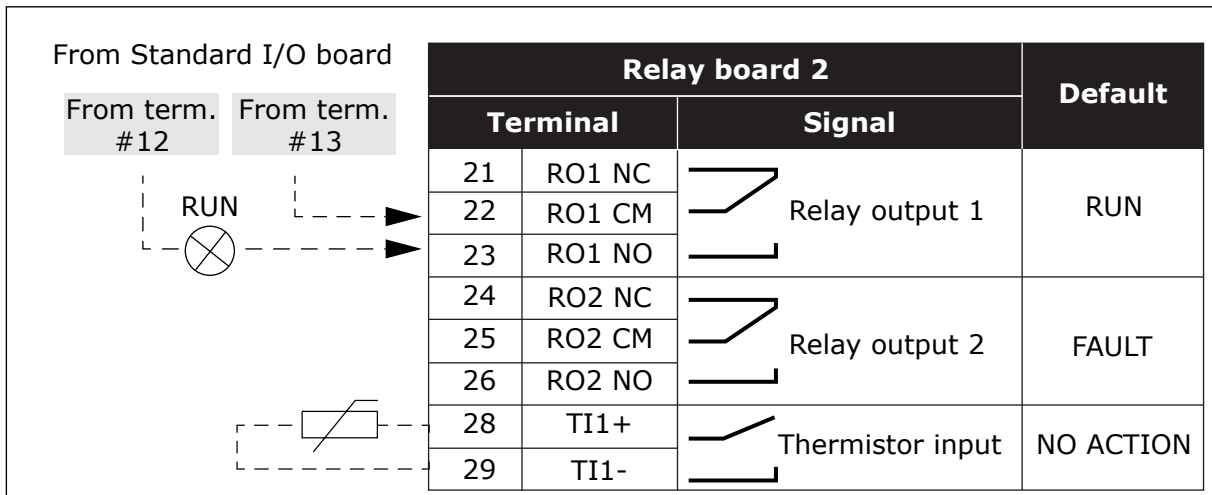

Fig. 41: The optional relay board (+SBF4)



NOTE!

The Thermistor input function is not automatically active.

To use the Thermistor input function, you must activate the parameter Thermistor Fault in the software. See the Application Manual.

6.2.2.1 Selection of terminal functions with DIP switches

You can make 2 selections with the DIP switches for specified terminals. The switches have 2 positions: up and down. You can see the location of the DIP switches and the possible selections in Fig. 42.

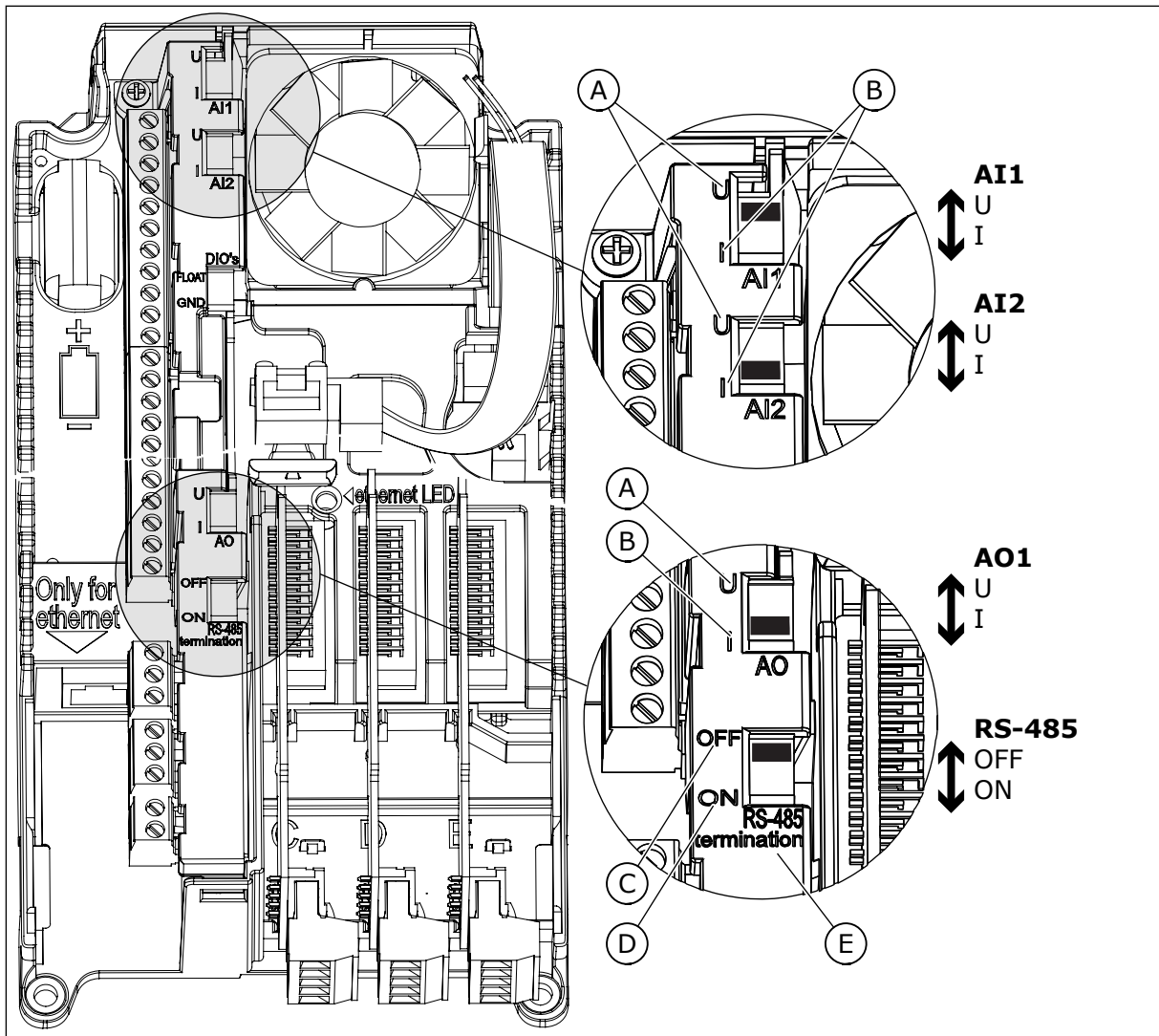

Fig. 42: The selections of the DIP switches

- A. The voltage signal (U), 0-10 V input
- B. The current signal (I), 0-20 mA input
- C. OFF
- D. ON
- E. The RS-485 bus termination

Table 29: The default positions of the DIP switches

The DIP switch	The default position
AI1	U
AI2	I
AO1	I
RS485 bus termination	OFF

6.2.2.2 Isolation of digital inputs from ground

It is possible to isolate from ground the digital inputs (terminals 8-10 and 14-16) on the standard I/O board. To do this, change the position of a DIP switch on the control board.

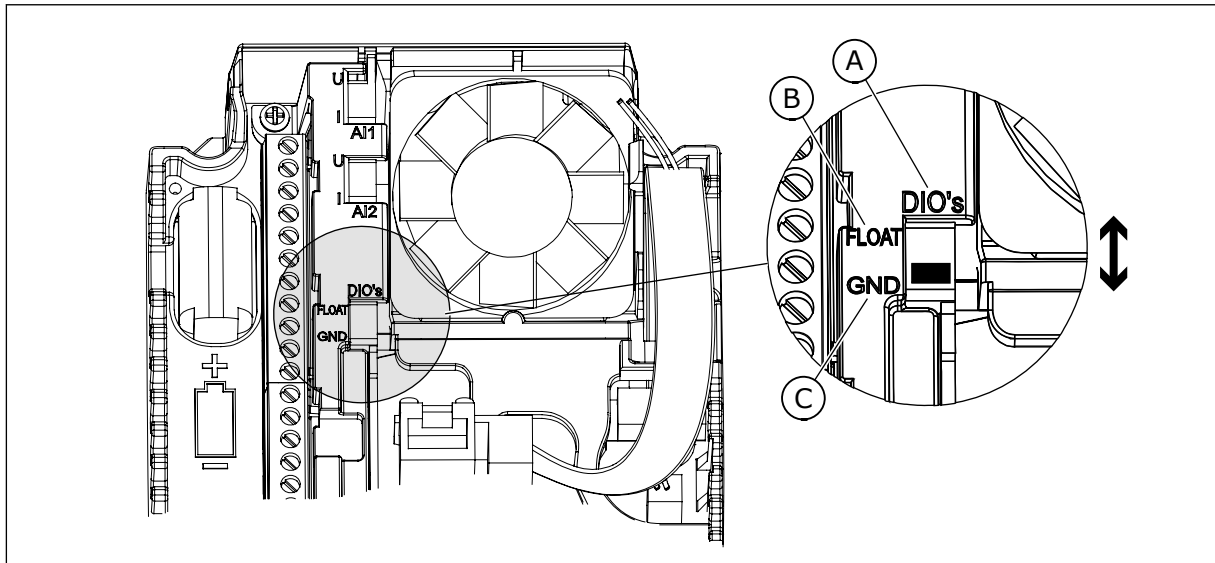

Fig. 43: Change the position of this switch to isolate the digital inputs from ground

- A. The digital inputs
- B. Floating
- C. Connected to GND (default)

6.3 FIELDBUS CONNECTION

You can connect the drive to fieldbus with an RS485 or an Ethernet cable. If you use an RS485 cable, connect it to terminal A and B of the standard I/O board. If you use an Ethernet cable, connect it to the Ethernet terminal below the cover of the drive.

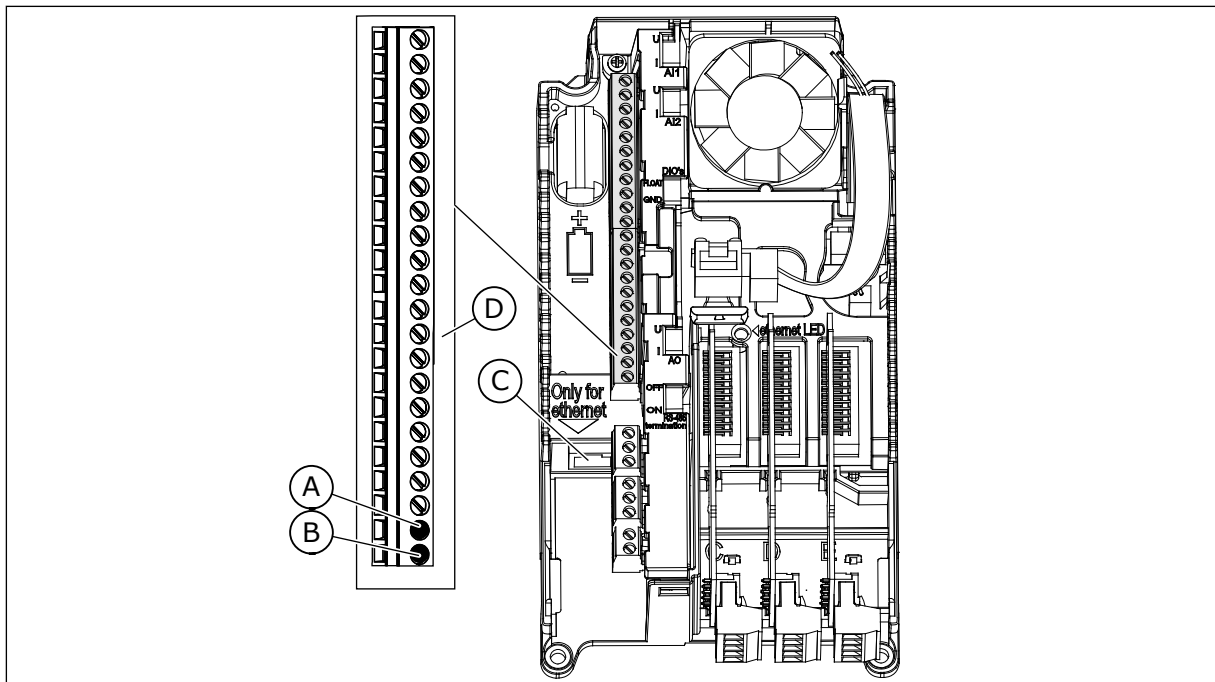

Fig. 44: The Ethernet and RS485 connections

- A. RS485 terminal A = Data -
- B. RS485 terminal B = Data +
- C. The Ethernet terminal
- D. The control terminals

6.3.1 USING FIELDBUS THROUGH AN ETHERNET CABLE

Table 30: Ethernet cable data

Item	Description
The plug type	A shielded RJ45 plug, maximum length 40 mm (1.57 in)
The cable type	CAT5e STP
The cable length	Maximum 100 m (328 ft)

ETHERNET CABLING

- 1 Connect the Ethernet cable to its terminal.

- 2 In IP21, cut free the opening on the cover of the AC drive for the Ethernet cable.
In IP54, cut a hole in a grommet and move the cable through it.
- a) If the grommet folds in when you put the cable, pull the cable back to make the grommet straight.
 - b) The hole in the grommet must not be wider than your cable.
 - c) Pull the first bit of the cable out of the grommet so that it stays straight. If this is not possible, make the connection tight with some insulation tape or a cable tie.

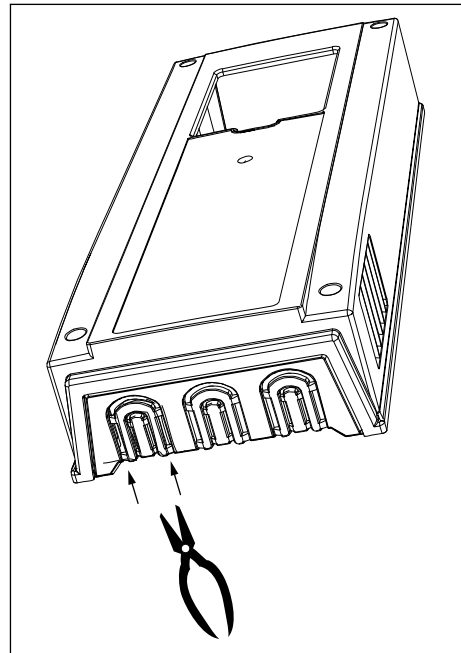

IP21

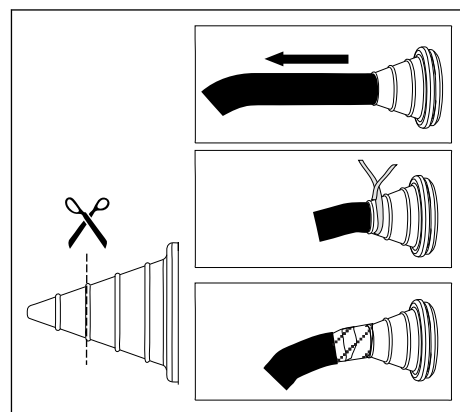

IP54

- Put the cover of the drive back. Keep the distance between the Ethernet cable and the motor cable at a minimum of 30 cm (11.81 in).

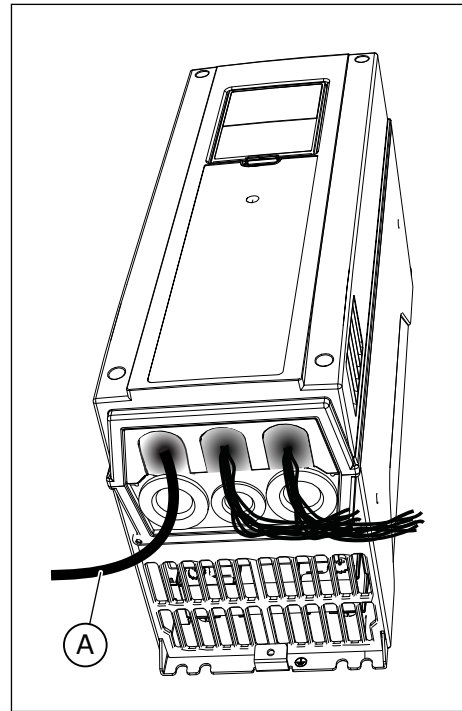

A. The Ethernet cable in IP21

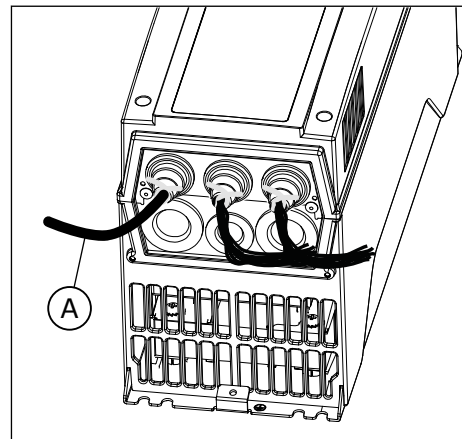

A. The Ethernet cable in IP54

See more in the Installation Manual of the fieldbus that you have.

6.3.2 USING FIELDBUS THROUGH AN RS485 CABLE

Table 31: RS485 cable data

Item	Description
The plug type	2.5 mm ²
The cable type	STP (shielded twisted pair), Belden 9841 or almost the same
The cable length	So that it agrees with the fieldbus. See the fieldbus manual.

RS485 CABLING

- 1 Remove approximately 15 mm (0.59 in) of the grey shield of the RS485 cable. Do this for the 2 fieldbus cables.
 - a) Strip the cables for approximately 5 mm (0.20 in) to put them in the terminals. Do not keep more than 10 mm (0.39 in) of the cable outside the terminals.
 - b) Strip the cable at such a distance from the terminal that you can attach it to the frame with the grounding clamp for control cable. Strip the cable at a maximum length of 15 mm (0.59 in). Do not remove the aluminium shield of the cable.

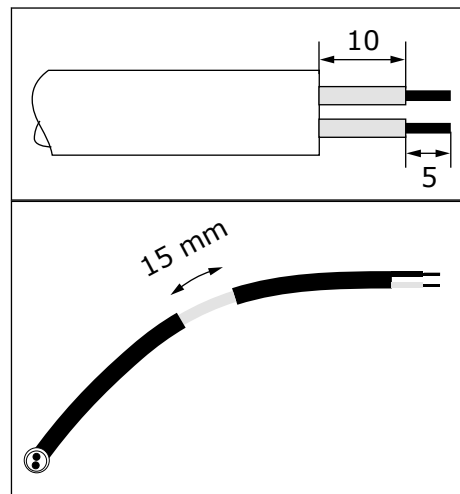

- 2 Connect the cable to the standard I/O board of the drive, in terminals A and B.

- A = negative
- B = positive

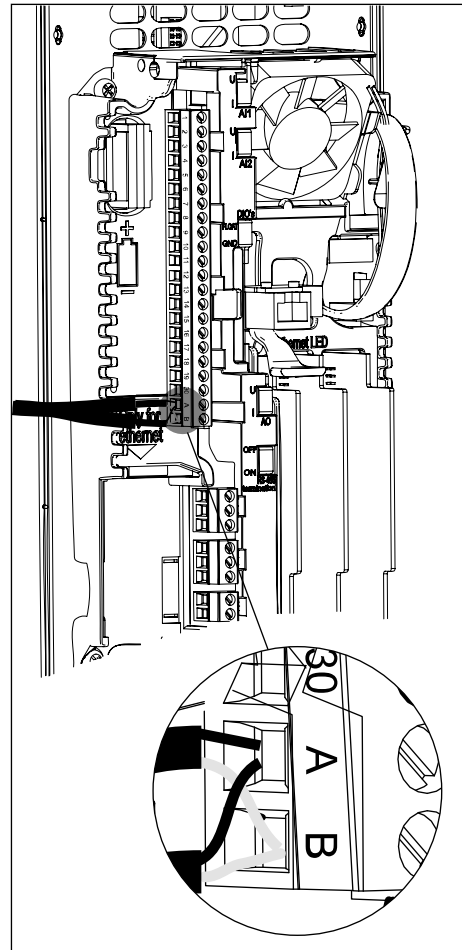

- 3 Attach the shield of the cable to the frame of the drive with a grounding clamp for control cable to make a grounding connection.

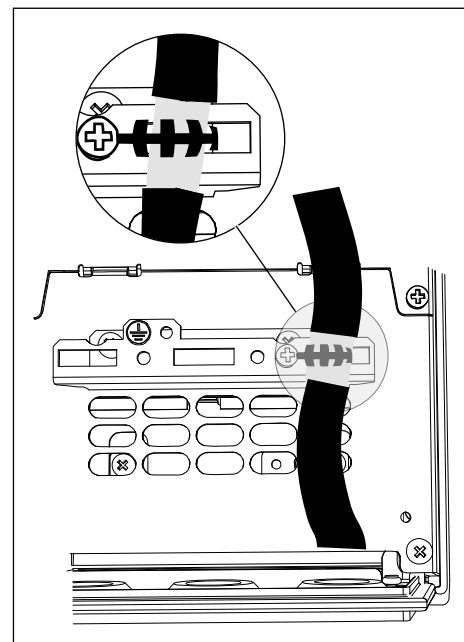

- 4 If the drive is the last device on the fieldbus line, set the bus termination.
- Find the DIP switches on the left side of the control unit of the drive.
 - Set the DIP switch of the RS485 bus termination to the ON position.
 - Biasing is built in the bus termination resistor. The termination resistance is 220 Ω .

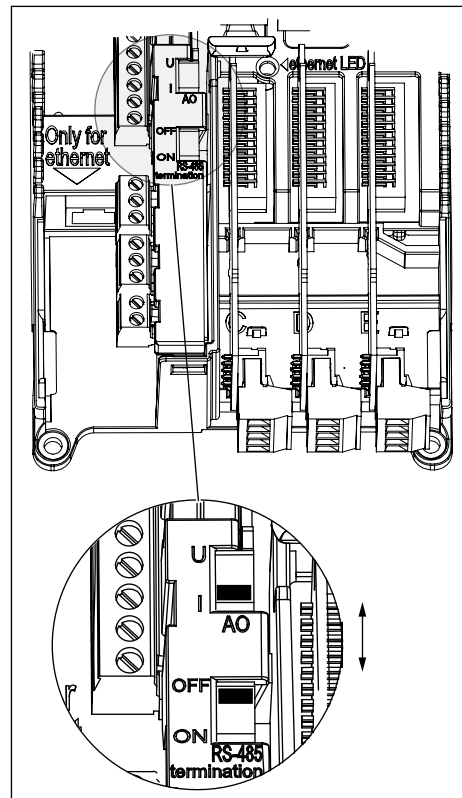

- 5 In IP21, unless you have cut the openings for other cables, cut an opening on the cover of the drive for the RS485 cable.

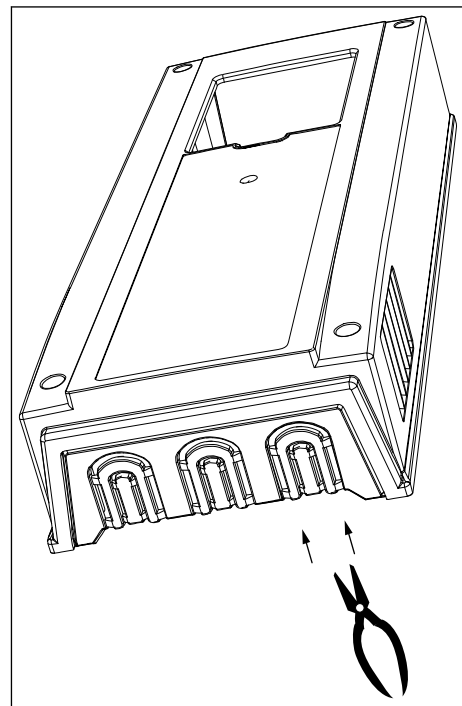

- 6 Put the cover of the drive back. Pull the RS485 cables to the side.
 - a) Keep the distance of the Ethernet, I/O and Fieldbus cables from the motor cable at a minimum of 30 cm (11.81 in).
 - b) Move the fieldbus cables away from the motor cable.

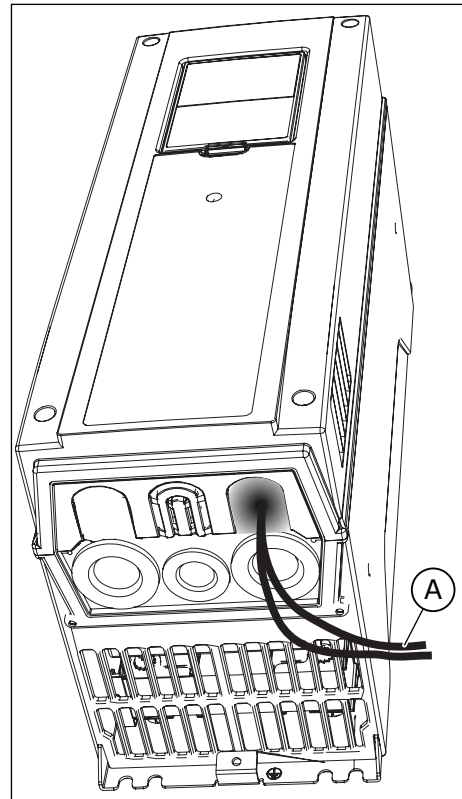

A. The fieldbus cables

- 7 Set the bus termination for the first and the last device of the fieldbus line. We recommend that the first device on the fieldbus is the master device.

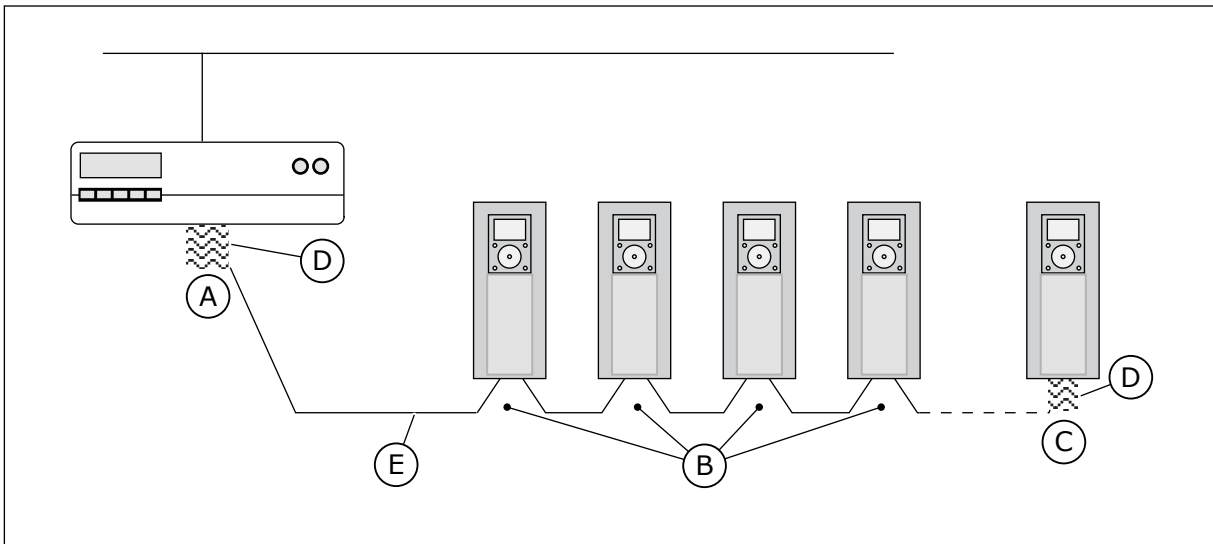

- | | |
|---|--|
| A. The termination is activated | D. The bus termination. The resistance is 220 Ω. |
| B. The termination is deactivated | E. The fieldbus |
| C. The termination is activated with a DIP switch | |

**NOTE!**

If you do power-down to the last device, there is no bus termination.

6.4 INSTALLATION OF OPTION BOARDS

**CAUTION!**

Do not install, remove, or replace option boards on the drive when the power is on. Doing this can cause damage to the boards.

Install the option boards into the option board slots of the drive. Refer to *Table 32*.

Table 32: The option boards and their correct option board slots

Type of the option board	Description of the option board	The correct slot or slots
OPTB1	The I/O expander board	C, D, E
OPTB2	The Thermistor relay board	C, D, E
OPTB4	The I/O expander board	C, D, E
OPTB5	The Relay board	C, D, E
OPTB9	The I/O expander board	C, D, E
OPTBF	The I/O expander board	C, D, E
OPTBH	The Temperature measurement board	C, D, E
OPTBJ	The Safe Torque Off board	E
OPTC4	The LonWorks fieldbus board	D, E
OPTE3	The Profibus DPV1 fieldbus board	D, E
OPTE5	The Profibus DPV1 fieldbus board (with a type D connector)	D, E
OPTE6	The CanOpen fieldbus board	D, E
OPTE7	The DeviceNet fieldbus board	D, E

THE INSTALLATION PROCEDURE

- 1 Open the cover of the AC drive.



WARNING!

Do not touch the control terminals. They can have a dangerous voltage also when the drive is disconnected from mains.

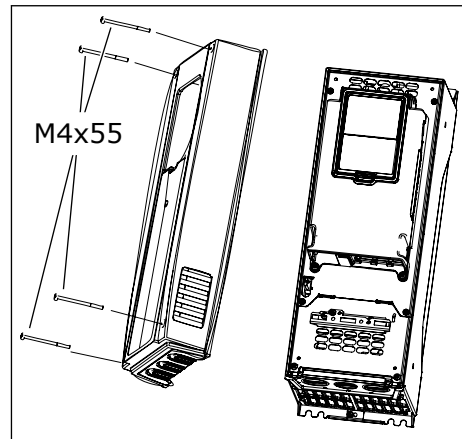

- 2 If you have an OPTB or an OPTC option board, make sure that the label on it says "dv" (dual voltage). This shows that the option board is compatible with the drive.



NOTE!

It is not possible to install option boards that are not compatible with the drive.

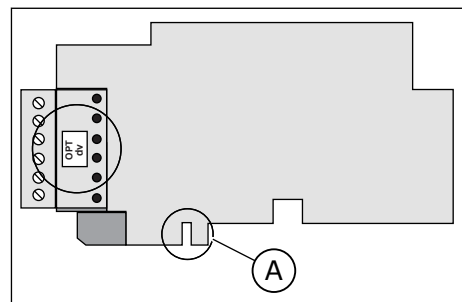

A. The slot coding

- 3 To get access to the option board slots, open the cover of the control unit.

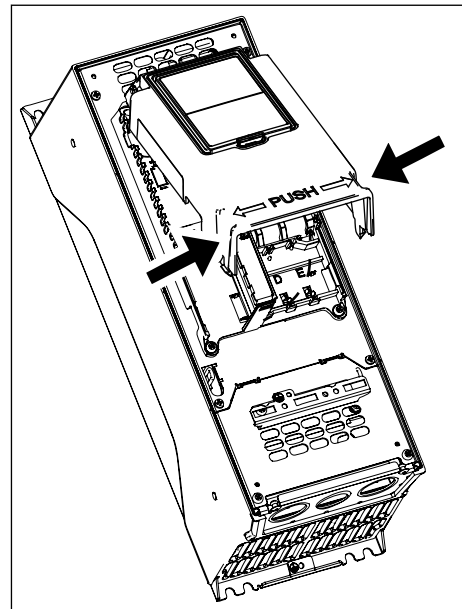

- 4 Install the option board into the correct slot: C, D or E. See *Table 32*.

- a) The option board has a slot coding, because of which it is not possible to install the option board in an incorrect slot.

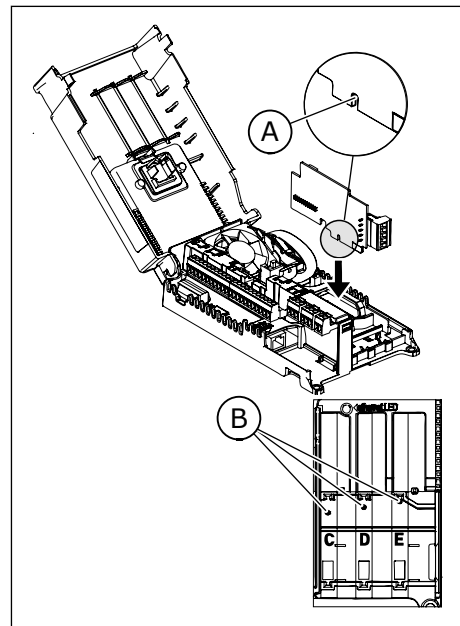

- A. The slot coding
B. The option board slots

- 5 Close the cover of the control unit. Put the cover of the AC drive back.

6.5 INSTALLATION OF A BATTERY FOR THE REAL TIME CLOCK (RTC)

To use the Real Time Clock (RTC), you must install a battery in the drive.

- 1 Use a ½ AA battery with 3.6 V and a capacity of 1000-1200 mAh. You can use, for example, a Panasonic BR-1/2 AA or a Vitzrocell SB-AA02.
- 2 Install the battery on the left side of the control panel. See *Fig. 38 The components of the control unit*.

The battery will last approximately 10 years. See more about the functions of the RTC in the Application Manual.

6.6 GALVANIC ISOLATION BARRIERS

The control connections are isolated from mains. The GND terminals are permanently connected to I/O ground.

The digital inputs on the standard I/O board can be galvanically isolated from the I/O ground. To isolate the digital inputs, use the DIP switch that has the positions FLOAT and GND.

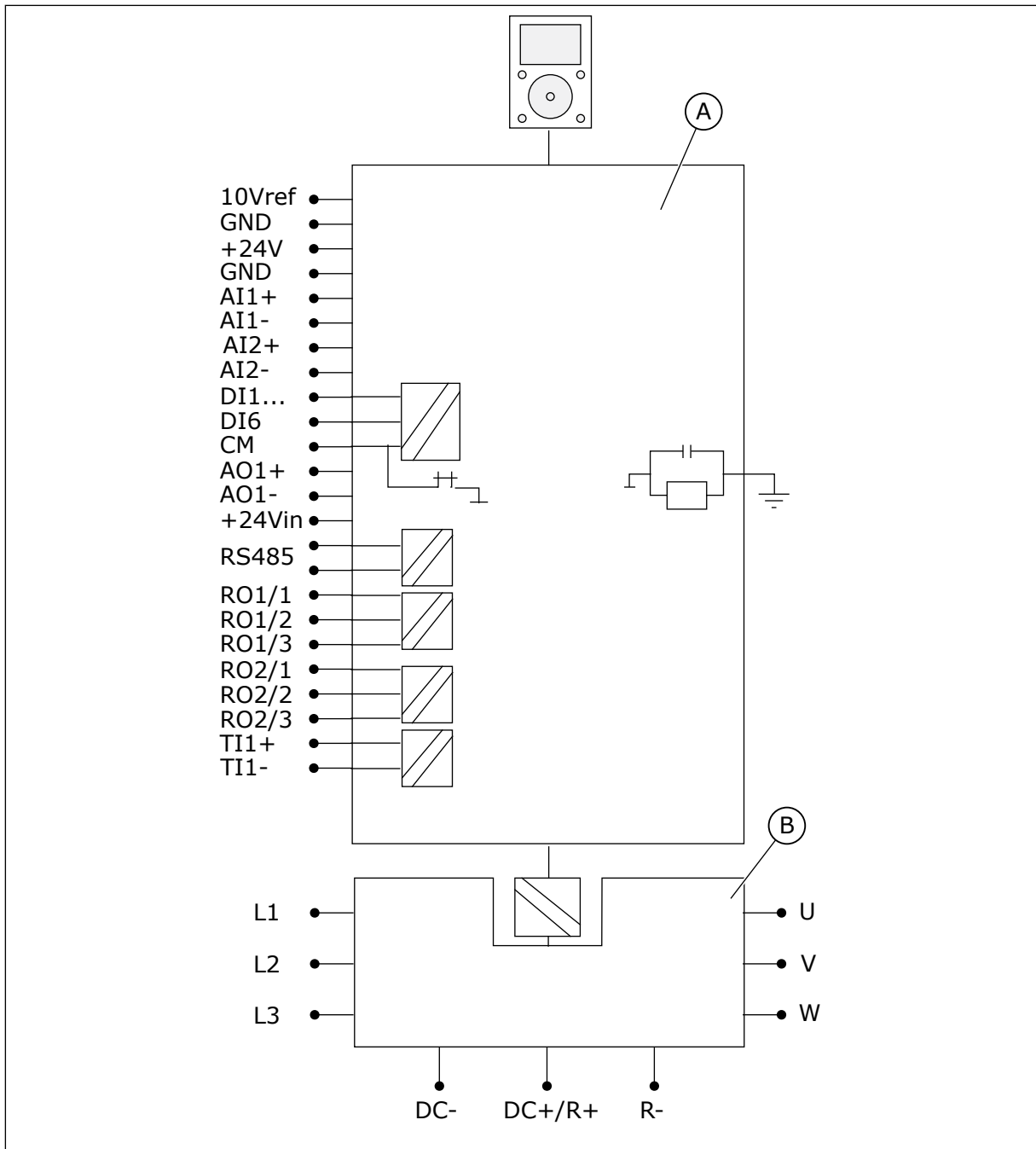

Fig. 45: The galvanic isolation barriers

A. The control unit

B. The power unit

7 COMMISSIONING AND ADDITIONAL INSTRUCTIONS

7.1 COMMISSIONING SAFETY

Before you start the commissioning, read these warnings.



WARNING!

Do not touch the internal components or the circuit boards of the drive when the drive is connected to mains. These components are live. A contact with this voltage is very dangerous. The galvanically isolated control terminals are not live.



WARNING!

Do not touch the motor cable terminals U, V, W, the brake resistor terminals or the DC terminals when the drive is connected to mains. These terminals are live when the drive is connected to mains, also when the motor does not operate.



WARNING!

Do not make connections to or from the AC drive when it is connected to mains. There is a dangerous voltage.



WARNING!

To do work on the connections of the drive, disconnect the drive from mains. Wait 5 minutes before you open the cover of the drive. Then use a measuring device to make sure that there is no voltage. The connections of the drive are live 5 minutes after it is disconnected from mains.



WARNING!

Before you do electrical work, make sure that there is no voltage.



WARNING!

Do not touch the control terminals. They can have a dangerous voltage also when the drive is disconnected from mains.



WARNING!

Before you connect the drive to mains, make sure that the front cover and the cable cover of the drive are closed. The connections of the AC drive are live when the drive is connected to mains.

7.2 COMMISSIONING OF THE DRIVE

Read the safety instructions in chapters 2 *Safety* and 7.1 *Commissioning safety* and obey them.

After the installation:

- Make sure that the motor is installed correctly.
- Make sure that the motor terminals are not connected to mains.
- Make sure that the AC drive and the motor are grounded.
- Make sure that you select the mains cable, the brake cable, and the motor cable correctly (see chapter 5.3 *Cable dimensioning and selection*).
- Make sure that the control cables are as far as possible from the power cables. See chapter 5.6 *Cable installation*.
- Make sure that the shields of the shielded cables are connected to a grounding terminal that is identified with ⊕ .
- Do a check of the tightening torques of all the terminals.
- Make sure that no power correction capacitors are connected to the motor cable.
- Make sure that the cables do not touch the electrical components of the drive.
- Make sure that the common inputs of the digital input groups are connected to +24 V or ground of the control terminal or the external power source.
- Do a check of the quality and quantity of the cooling air. See chapter 4.6 *Cooling* and Table 14 *The necessary quantity of cooling air*.
- Make sure that there is no condensation on the inner surfaces of the AC drive.
- Make sure that there are no unwanted objects in the installation space.
- Before you connect the drive to mains, do a check of the installation and the condition of all the fuses and other protective devices.

7.3 OPERATION OF THE MOTOR**7.3.1 CHECKS BEFORE STARTING THE MOTOR****Before you start the motor, do these checks.**

- Make sure that all the START and STOP switches that are connected to the control terminals are in the STOP position.
- Make sure that you can start the motor safely.
- Activate the Start-up wizard. See the Application Manual for the AC drive that you have.
- Set the maximum frequency reference (that is, the maximum speed of the motor), so that it agrees with the motor and the device that is connected to the motor.

7.4 MEASURING THE CABLE AND MOTOR INSULATION

Do these checks if necessary.

The insulation checks of the motor cable

1. Disconnect the motor cable from the terminals U, V, and W and from the motor.
2. Measure the insulation resistance of the motor cable between phase conductors 1 and 2, between phase conductors 1 and 3, and between phase conductors 2 and 3.
3. Measure the insulation resistance between each phase conductor and the grounding conductor.
4. The insulation resistance must be >1 MΩ at the ambient temperature of 20 °C (68 °F).

The insulation checks of the mains cable

1. Disconnect the mains cable from the terminals L1, L2, and L3 and from mains.
2. Measure the insulation resistance of the mains cable between phase conductors 1 and 2, between phase conductors 1 and 3, and between phase conductors 2 and 3.
3. Measure the insulation resistance between each phase conductor and the grounding conductor.
4. The insulation resistance must be $>1 \text{ M}\Omega$ at the ambient temperature of $20 \text{ }^\circ\text{C}$ ($68 \text{ }^\circ\text{F}$).

The insulation checks of the motor

1. Disconnect the motor cable from the motor.
2. Open the bridging connections in the motor connection box.
3. Measure the insulation resistance of each motor winding. The voltage must be the same or higher than the motor nominal voltage, but not higher than 1000 V.
4. The insulation resistance must be $>1 \text{ M}\Omega$ at the ambient temperature of $20 \text{ }^\circ\text{C}$ ($68 \text{ }^\circ\text{F}$).
5. Obey the instructions of the motor manufacturer.

7.5 INSTALLATION IN A MARINE ENVIRONMENT

When you install the AC drive in a marine environment, see the Marine Installation Guide.

7.6 INSTALLATION IN AN IT SYSTEM

If your mains is impedance-grounded (IT), the AC drive must have the EMC protection level C4. If your drive has the EMC protection level C2 or C3, it is necessary to change it to C4. To do this, remove the EMC jumpers. For a 600 and 690V product that is configured for a C4 installation on IT network the maximum switching frequency is limited to default 2 kHz.



WARNING!

Do not make changes in the AC drive when it is connected to mains. The components of the drive are live when the drive is connected to mains.



CAUTION!

Before you connect the AC drive to mains, make sure that the EMC level of the drive is correct. An incorrect EMC level can cause damage to the drive.

7.6.1 THE EMC JUMPER IN MR4, MR5 AND MR6

Change the EMC protection of the AC drive to level C4.

1. Open the cover of the AC drive.
2. In MR4 and MR5, to find the EMC jumpers, remove the cable cover.

- 3 Find the EMC jumpers that connect the RFI filters to ground.

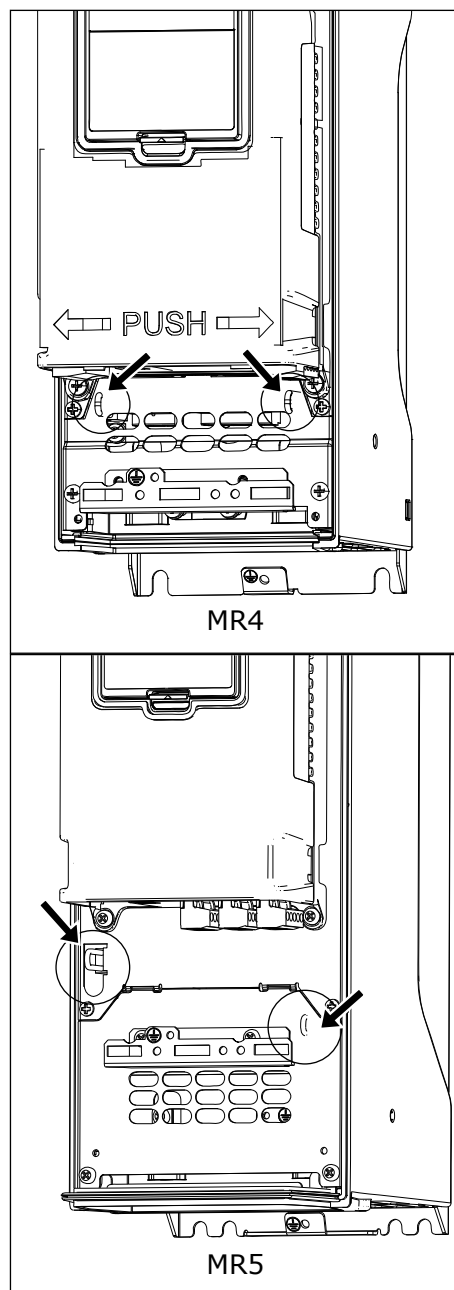

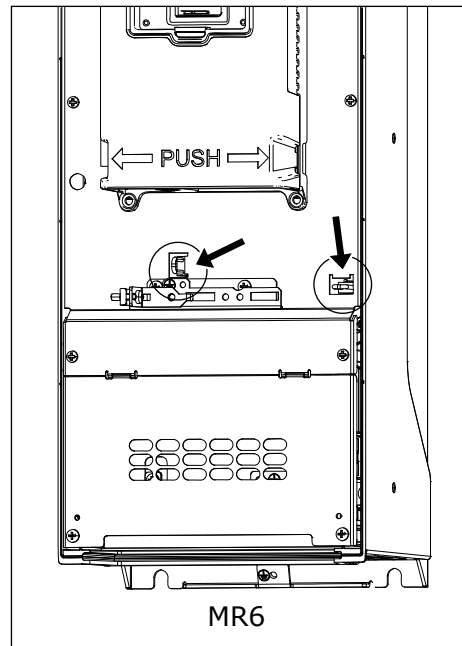

200-500 V

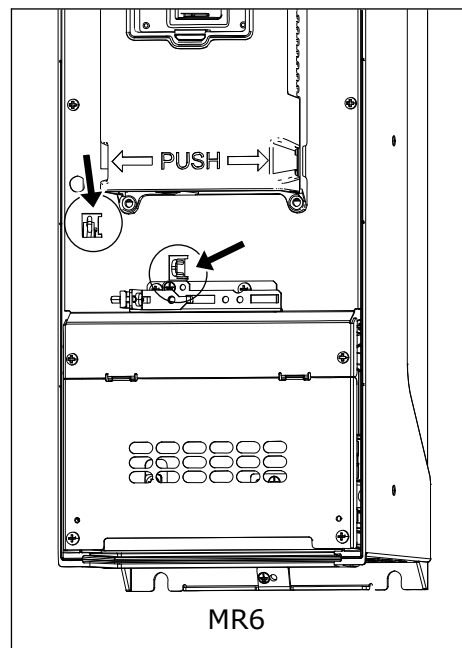

600/690 V

- 4 To disconnect the RFI filters from ground, remove the EMC jumpers. Pull the EMC jumper out with the tool.

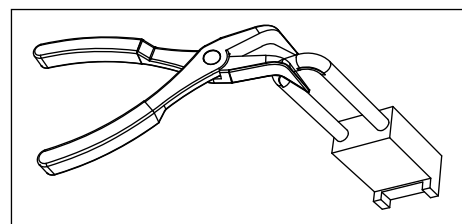

- 5 After the change, write "The EMC level was changed" and the date on the "product modified" label. If the label is not attached at this time, attach it on the drive near the name plate.

Product modified
Date:
Date:
Date:

7.6.2 THE EMC JUMPER IN MR7

Change the EMC protection of the AC drive to level C4.

HOW TO FIND THE EMC JUMPERS, 200-500 V

- 1 Open the cover of the AC drive.
- 2 Find the EMC box. To get access to the EMC jumper, remove the cover of the EMC box.

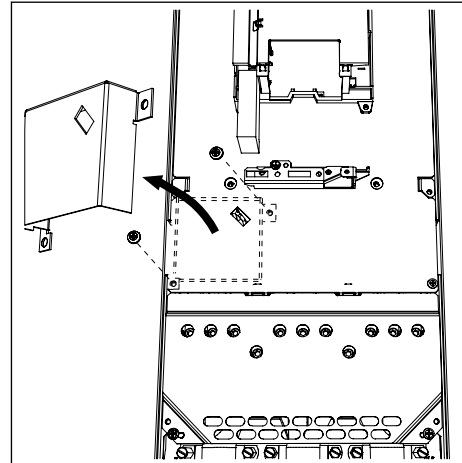

- 3 Remove the EMC jumper. Attach the cover of the EMC box again.

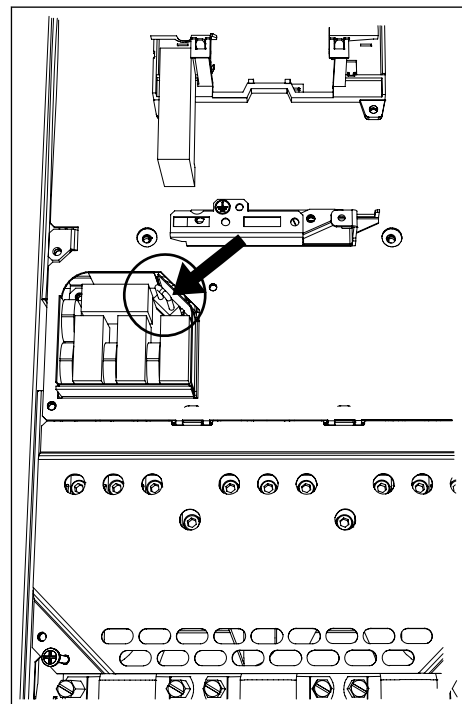

- 4 Find the DC grounding busbar between the terminals R- and U. To remove the busbar from the frame, remove the M4 screw.

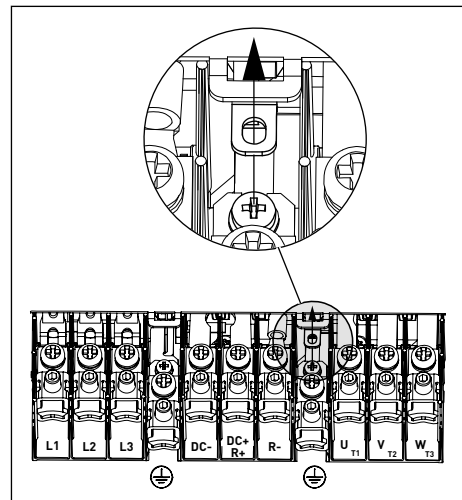

- 5 After the change, write "The EMC level was changed" and the date on the "product modified" label. If the label is not attached at this time, attach it on the drive near the name plate.

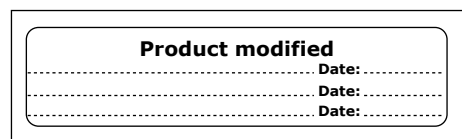

HOW TO FIND THE EMC JUMPERS, 600/690 V

- 1 Open the cover of the AC drive.
- 2 Remove the terminal cover.

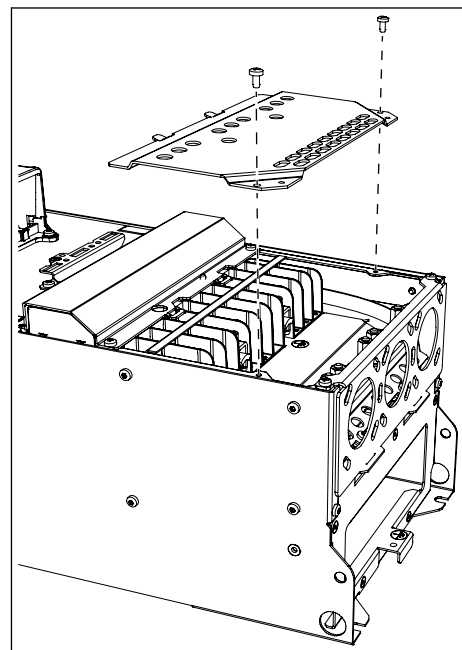

- 3 Remove the EMC jumper.

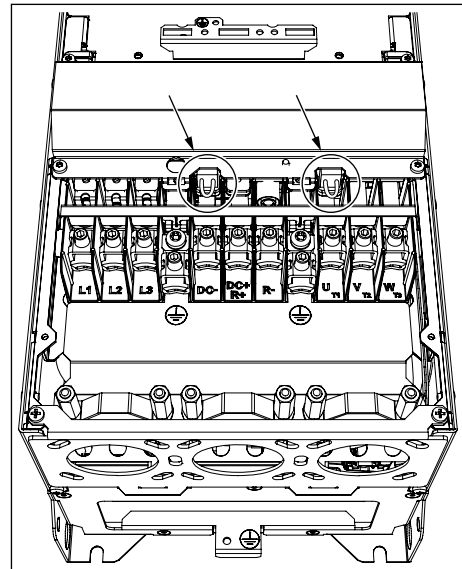

- 4 After the change, write "The EMC level was changed" and the date on the "product modified" label. If the label is not attached at this time, attach it on the drive near the name plate.

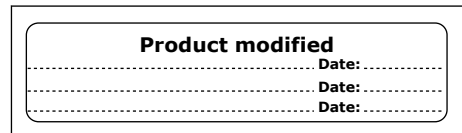

7.6.3 THE EMC JUMPER IN MR8

Change the EMC protection of the AC drive to level C4.

- 1 Open the cover of the AC drive.
- 2 Find the EMC box. To get access to the EMC jumper, remove the cover of the EMC box.

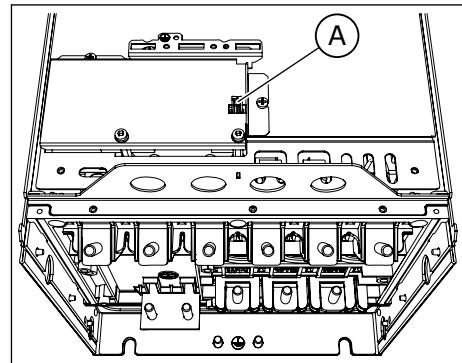

A. The EMC jumper

- 3 Remove the EMC jumper. Attach the cover of the EMC box again.

- 4 Find the grounding arm and push it down.

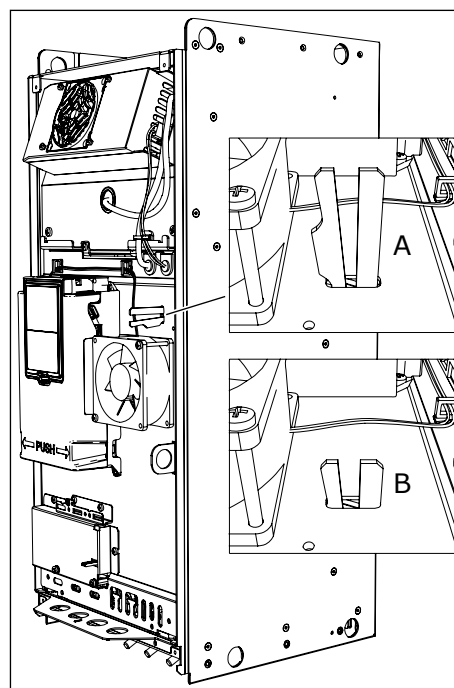

- A. The grounding arm is up
- B. The grounding arm is down (level C4)

- 5 After the change, write "The EMC level was changed" and the date on the "product modified" label. If the label is not attached at this time, attach it on the drive near the name plate.

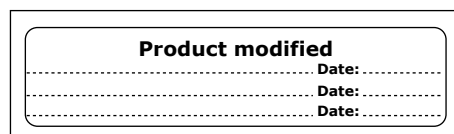

7.6.4 THE EMC JUMPER IN MR9

To make a change in the EMC protection of the AC drive, you must find the necessary EMC jumpers. To change the EMC level from C2 or C3 (in 690 V) to C4, remove the EMC jumpers. To change the EMC level from C4 to C2 or C3, install the EMC jumpers. You can find the EMC jumpers, which are not installed, in the accessories bag.

HOW TO FIND THE EMC JUMPER 1

- 1 Open the cover of the AC drive.
- 2 Remove the cover of the fan.
- 3 In IP54, also remove the fan.

- 4 Find the place of the jumper behind the fan.

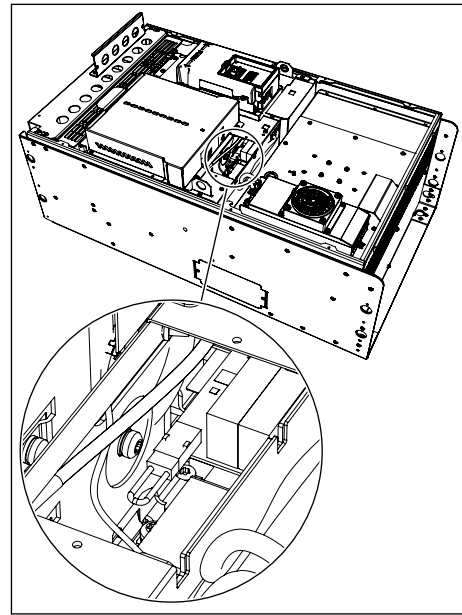

- 5 If you change the EMC level, write "The EMC level was changed" and the date on the "product modified" label. If the label is not attached at this time, attach it on the drive near the name plate.

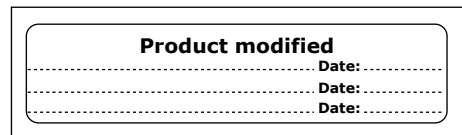

HOW TO FIND THE EMC JUMPERS 2 AND 3 (ONLY 200-500 V)

- 1 Remove the cover of the extension box, the touch shield, and the I/O plate with the I/O grommet plate.
- 2 Find the 2 EMC jumpers on the EMC board. They are not adjacent to each other.

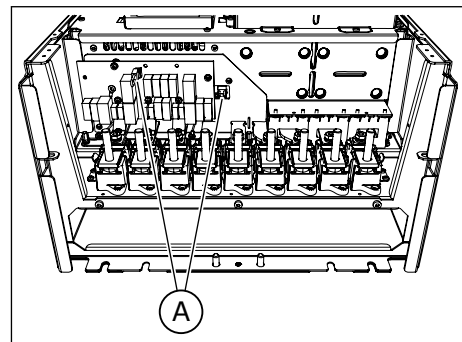

- 3 If you change the EMC level, write "The EMC level was changed" and the date on the "product modified" label. If the label is not attached at this time, attach it on the drive near the name plate.

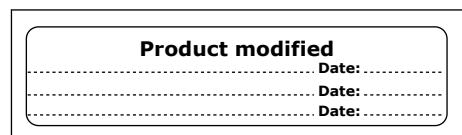

7.7 MAINTENANCE

To make sure that the drive operates correctly and has a long life, we recommend that you do regular maintenance. Refer to the table for maintenance intervals.

It is not necessary to replace the main capacitors of the drive, because they are a thin film type capacitors.

Table 33: The maintenance intervals and tasks

Maintenance interval	Maintenance task
Regularly	Do a check of the tightening torques of the terminals. Do a check of the filters.
6-24 months (The interval is different in different environments.)	Do a check of the mains cable terminals, the motor cable terminals and the control terminals. Make sure that the cooling fan operates correctly. Make sure that there is no corrosion on the terminals, the busbars or other surfaces. Do a check of the door filters, if you have a cabinet installation.
24 months (The interval is different in different environments.)	Clean the heatsink and the cooling tunnel.
3-6 years	In IP54, change the internal fan.
6-10 years	Change the main fan.
10 years	Replace the battery of the RTC.

8 TECHNICAL DATA, VACON® 100

8.1 AC DRIVE POWER RATINGS

8.1.1 MAINS VOLTAGE 208-240 V

Table 34: The power ratings of Vacon® 100 in mains voltage 208-240 V, 50-60 Hz, 3~

Frame	Drive type	Loadability							Motor shaft power			
		Low *			High *			Max current I _s 2s	230 V mains		230 V mains	
		Continuous current I _L [A]	Input current I _{in} [A]	10% overload current [A]	Continuous current I _H [A]	Input current I _{in} [A]	50% overload current [A]		10% overload 40°C [kW]	50% overload 50°C [kW]	10% overload 40°C [hp]	50% overload 50°C [hp]
MR4	0003	3.7	3.2	4.1	2.6	2.4	3.9	5.2	0.55	0.37	0.75	0.5
	0004	4.8	4.2	5.3	3.7	3.2	5.6	7.4	0.75	0.55	1.0	0.75
	0007	6.6	6.0	7.3	4.8	4.5	7.2	9.6	1.1	0.75	1.5	1.0
	0008	8.0	7.2	8.8	6.6	6.0	9.9	13.2	1.5	1.1	2.0	1.5
	0011	11.0	9.7	12.1	8.0	7.2	12.0	16.0	2.2	1.5	3.0	2.0
	0012	12.5	10.9	13.8	9.6	8.6	16.5	19.6	3.0	2.2	4.0	3.0
MR5	0018	18.0	16.1	19.8	12.5	11.5	18.8	25.0	4.0	3.0	5.0	4.0
	0024	24.0	21.7	26.4	18.0	16.1	27.0	36.0	5.5	4.0	7.5	5.0
	0031	31.0	27.7	34.1	25.0	22.5	37.5	46.0	7.5	5.5	10.0	7.5
MR6	0048	48.0	43.8	52.8	31.0	28.5	46.5	62.0	11.0	7.5	15.0	10.0
	0062	62.0	57.0	68.2	48.0	44.2	72.0	96.0	15.0	11.0	20.0	15.0
MR7	0075	75.0	69.0	82.5	62.0	57.0	93.0	124.0	18.5	15.0	25.0	20.0
	0088	88.0	82.1	96.8	75.0	70.0	112.5	150.0	22.0	18.5	30.0	25.0
	0105	105.0	99.0	115.5	88.0	82.1	132.0	176.0	30.0	22.0	40.0	30.0
MR8	0140	140.0	135.1	154.0	114.0	109.0	171.0	210.0	37.0	30.0	50.0	40.0
	0170	170.0	162.0	187.0	140.0	133.0	210.0	280.0	45.0	37.0	60.0	50.0
	0205	205.0	200.0	225.5	170.0	163.0	255.0	340.0	55.0	45.0	75.0	60.0
MR9	0261	261.0	253.0	287.1	211.0	210.0	316.5	410.0	75.0	55.0	100.0	75.0
	0310	310.0	301.0	341.0	251.0	246.0	376.5	502.0	90.0	75.0	125.0	100.0

* = See chapter 8.1.5 *Overload capability*.

**NOTE!**

The currents in given ambient temperatures (in chapter 8.2 *Vacon® 100 - technical data*) are achieved only when the switching frequency is equal to or less than the factory default.

If your process includes a cyclical load, for example if there are lifts or winches, speak to the manufacturer to get the dimensioning information.

8.1.2 MAINS VOLTAGE 380-500 V

Table 35: The power ratings of Vacon® 100 in mains voltage 380-500 V, 50-60 Hz, 3~

Frame	Drive type	Loadability						Motor shaft power				
		Low *			High *			Max current Is 2s	400 V mains		480 V mains	
		Continuous current IL [A]	Input current I _{in} [A]	10% overload current [A]	Continuous current I _H [A]	Input current I _{in} [A]	50% overload current [A]		10% overload 40°C [kW]	50% overload 50°C [kW]	10% overload 40°C [hp]	50% overload 50°C [hp]
MR4	0003	3.4	3.4	3.7	2.6	2.8	3.9	5.2	1.1	0.75	1.5	1.0
	0004	4.8	4.6	5.3	3.4	3.4	5.1	6.8	1.5	1.1	2.0	1.5
	0005	5.6	5.4	6.2	4.3	4.2	6.5	8.6	2.2	1.5	3.0	2.0
	0008	8.0	8.1	8.8	5.6	6.0	8.4	11.2	3.0	2.2	4.0	3.0
	0009	9.6	9.3	10.6	8.0	8.1	12.0	16.0	4.0	3.0	5.0	4.0
	0012	12.0	11.3	13.2	9.6	9.3	14.4	19.2	5.5	4.0	7.5	5.0
MR5	0016	16.0	15.4	17.6	12.0	12.4	18.0	24.0	7.5	5.5	10.0	7.5
	0023	23.0	21.3	25.3	16.0	15.4	24.0	32.0	11.0	7.5	15.0	10.0
	0031	31.0	28.4	34.1	23.0	21.6	34.5	46.0	15.0	11.0	20.0	15.0
MR6	0038	38.0	36.7	41.8	31.0	30.5	46.5	62.0	18.5	15.0	25.0	20.0
	0046	46.0	43.6	50.6	38.0	36.7	57.0	76.0	22.0	18.5	30.0	25.0
	0061	61.0	58.2	67.1	46.0	45.6	69.0	92.0	30.0	22.0	40.0	30.0
MR7	0072	72.0	67.5	79.2	61.0	58.2	91.5	122.0	37.0	30.0	50.0	40.0
	0087	87.0	85.3	95.7	72.0	72.0	108.0	144.0	45.0	37.0	60.0	50.0
	0105	105.0	100.6	115.5	87.0	85.3	130.5	174.0	55.0	45.0	75.0	60.0
MR8	0140	140.0	139.4	154.0	105.0	109.0	157.5	210.0	75.0	55.0	100.0	75.0
	0170	170.0	166.5	187.0	140.0	139.4	210.0	280.0	90.0	75.0	125.0	100.0
	0205	205.0	199.6	225.5	170.0	166.5	255.0	340.0	110.0	90.0	150.0	125.0
MR9	0261	261.0	258.0	287.1	205.0	204.0	307.5	410.0	132.0	110.0	200.0	150.0
	0310	310.0	303.0	341.0	251.0	246.0	376.5	502.0	160.0	132.0	250.0	200.0

* = See chapter 8.1.5 Overload capability.



NOTE!

The currents in given ambient temperatures (in chapter 8.2 *Vacon® 100 - technical data*) are achieved only when the switching frequency is equal to or less than the factory default.

If your process includes a cyclical load, for example if there are lifts or winches, speak to the manufacturer to get the dimensioning information.

8.1.3 MAINS VOLTAGE 525-600 V

Table 36: The power ratings of Vacon® 100 in mains voltage 525-600 V, 50-60 Hz, 3~

Frame	Drive type	Loadability							Motor shaft power	
		Low			High			Max current I _s 2s	600 V	
		Continu- ous current I _L [A]	Input current I _{in} [A]	10% over- load current [A]	Continu- ous current I _H [A]	Input current I _{in} [A]	50% over- load current [A]		10% over- load 40°C [Hp]	50% over- load 50°C [Hp]
MR5	0004	3.9	4.6	4.3	2.7	3.2	4.1	5.4	3.0	2.0
	0006	6.1	6.8	6.7	3.9	4.5	5.9	7.8	5.0	3.0
	0009	9.0	9.0	9.9	6.1	6.7	9.2	12.2	7.5	5.0
	0011	11.0	10.5	12.1	9.0	8.9	13.5	18.0	10.0	7.5
MR6	0018	18.0	19.9	19.8	13.5	15.2	20.3	27.0	15.0	10.0
	0022	22.0	23.3	24.2	18.0	19.8	27.0	36.0	20.0	15.0
	0027	27.0	27.2	29.7	22.0	23.1	33.0	44.0	25.0	20.0
	0034	34.0	32.8	37.4	27.0	27.0	40.5	54.0	30.0	25.0
MR7	0041	41.0	45.3	45.1	34.0	38.4	51.0	68.0	40.0	30.0
	0052	52.0	53.8	57.2	41.0	44.9	61.5	82.0	50.0	40.0
	0062	62.0	62.2	68.2	52.0	53.2	78.0	104.0	60.0	50.0
MR8	0080	80.0	90.0	88.0	62.0	72.0	93.0	124.0	75.0	60.0
	0100	100.0	106.0	110.0	80.0	89.0	120.0	160.0	100.0	75.0
	0125	125.0	127.0	137.5	100.0	104.0	150.0	200.0	125.0	100.0
MR9	0144	144.0	156.0	158.4	125.0	140.0	187.5	250.0	150.0	125.0
	0208	208.0	212.0	228.8	170.0	177.0	255.0	340.0	200.0	150.0

8.1.4 MAINS VOLTAGE 525-690 V

Table 37: The power ratings of Vacon® 100 in mains voltage 525-690 V, 50-60 Hz, 3~

Frame	Drive type	Loadability							Motor shaft power			
		Low			High			Max current I _s 2s	600 V		690 V	
		Continuous current I _L [A]	Input current I _{in} [A]	10% overload current [A]	Continuous current I _H [A]	Input current I _{in} [A]	50% overload current [A]		10% overload 40°C [Hp]	50% overload 50°C [Hp]	10% overload 40°C [kW]	50% overload 50°C [kW]
MR6	0007	7.5	9.1	8.3	5.5	6.8	8.3	11.0	5.0	3.0	5.5	4.0
	0010	10.0	11.7	11.0	7.5	9.0	11.3	15.0	7.5	5.0	7.5	5.5
	0013	13.5	15.5	14.9	10.0	11.6	15.0	20.0	10.0	7.5	11.0	7.5
	0018	18.0	19.9	19.8	13.5	15.2	20.3	27.0	15.0	10.0	15.0	11.0
	0022	22.0	23.3	24.2	18.0	19.8	27.0	36.0	20.0	15.0	18.5	15.0
	0027	27.0	27.2	29.7	22.0	23.1	33.0	44.0	25.0	20.0	22.0	18.5
	0034	34.0	32.8	37.4	27.0	27.0	40.5	54.0	30.0	25.0	30.0	22.0
MR7	0041	41.0	45.3	45.1	34.0	38.4	51.0	68.0	40.0	30.0	37.0	30.0
	0052	52.0	53.8	57.2	41.0	44.9	61.5	82.0	50.0	40.0	45.0	37.0
	0062	62.0	62.2	68.2	52.0	53.2	78.0	104.0	60.0	50.0	55.0	45.0
MR8	0080	80.0	90.0	88.0	62.0	72.0	93.0	124.0	75.0	60.0	75.0	55.0
	0100	100.0	106.0	110.0	80.0	89.0	120.0	160.0	100.0	75.0	90.0	75.0
	0125	125.0	127.0	137.5	100.0	104.0	150.0	200.0	125.0	100.0	110.0	90.0
MR9	0144	144.0	156.0	158.4	125.0	140.0	187.5	250.0	150.0	125.0	132.0	110.0
	0170	170.0	179.0	187.0	144.0	155.0	216.0	288.0	150.0	150.0	160.0	132.0
	0208	208.0	212.0	228.8	170.0	177.0	255.0	340.0	200.0	150.0	200.0	160.0

8.1.5 OVERLOAD CAPABILITY

The **low overload** means that if 110% of the continuous current (I_L) is necessary for 1 minute each 10 minutes, the remaining 9 minutes must be approximately 98% of I_L or less. This is to make sure that the output current is not more than I_L during the duty cycle.

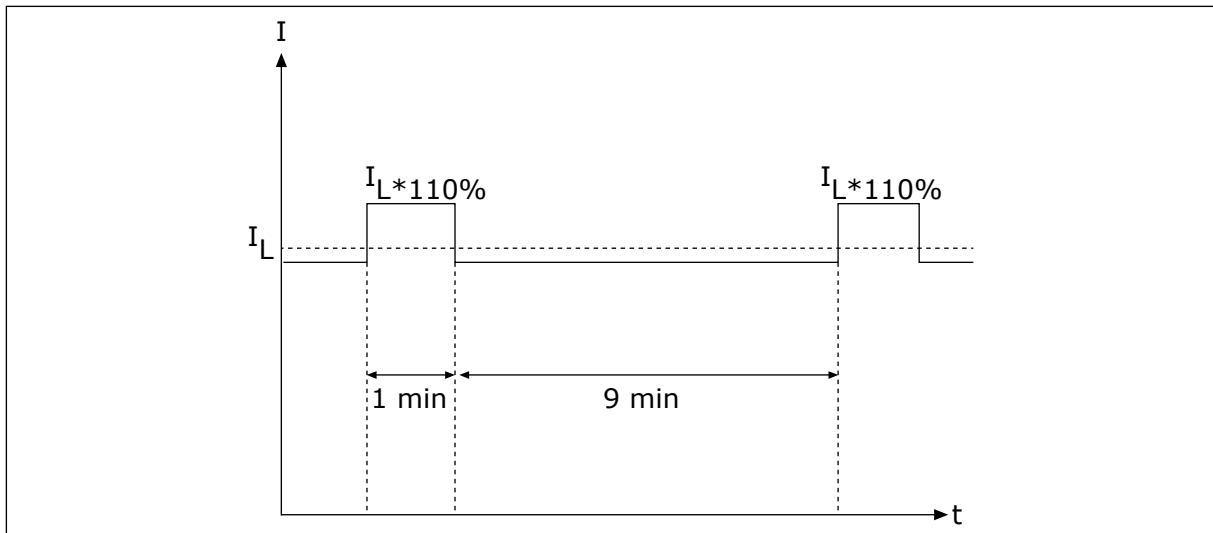

Fig. 46: Low overload

The **high overload** means that if 150% of the continuous current (I_H) is necessary for 1 minute each 10 minutes, the remaining 9 minutes must be approximately 92% of I_H or less. This is to make sure that the output current is not more than I_H during the duty cycle.

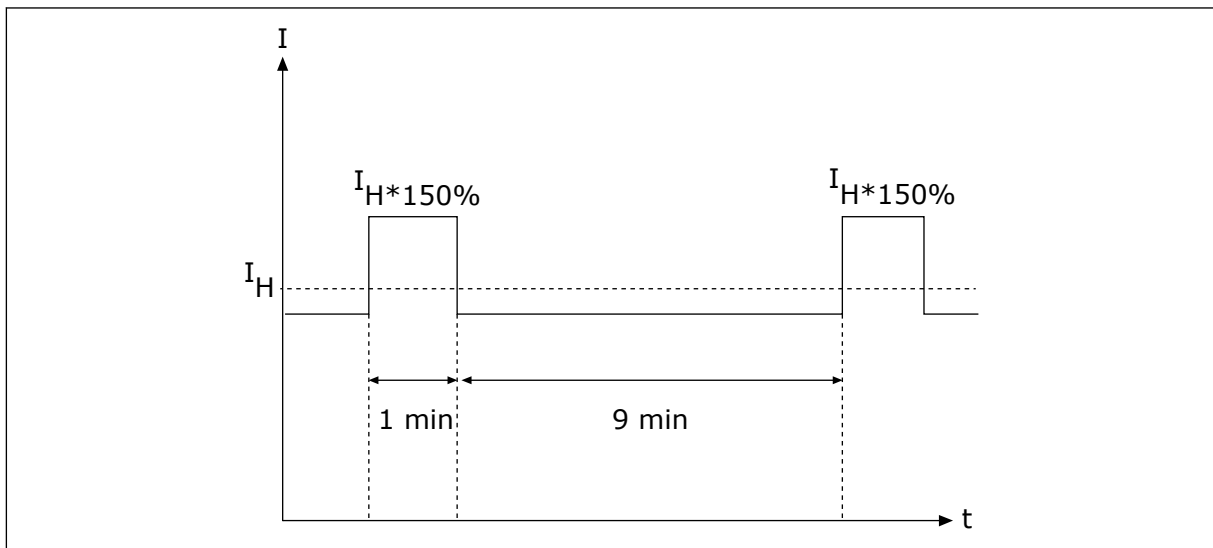

Fig. 47: High overload

For more information, refer to the standard IEC61800-2 (IEC:1998).

8.1.6 BRAKE RESISTOR RATINGS

Make sure that the resistance is higher than the set minimum resistance. The power handling capacity must be sufficient for the application.

Table 38: The recommended brake resistor types, mains voltage 208-240 V and 380-500 V

Frame	Duty cycle	Type of brake resistor	Resistance [Ω]
MR4	Light duty	BRR 0022 LD 5	63.0
	Heavy duty	BRR 0022 HD 5	63.0
MR5	Light duty	BRR 0031 LD 5	41.0
	Heavy duty	BRR 0031 HD 5	41.0
MR6	Light duty	BRR 0045 LD 5	21.0
	Heavy duty	BRR 0045 HD 5	21.0
MR7	Light duty	BRR 0061 LD 5	14.0
	Heavy duty	BRR 0061 HD 5	14.0
MR8	Light duty	BRR 0105 LD 5	6.5
	Heavy duty	BRR 0105 HD 5	6.5
MR9	Light duty	BRR 0300 LD 5	3.3
	Heavy duty	BRR 0300 HD 5	3.3

Table 39: The recommended brake resistor types, mains voltage 525-690 V

Frame	Drive type	Duty cycle	Type of brake resistor	Resistance [Ω]
MR5	0004-0011	Light duty	BRR 0013 LD 6	100
		Heavy duty	BRR 0013 HD 6	100
MR6	0007-0013	Light duty	BRR 0013 LD 6	100
		Heavy duty	BRR 0013 HD 6	100
	0018-0034	Light duty	BRR 0034 LD 6	30
		Heavy duty	BRR 0034 HD 6	30
MR7	0041	Light duty	BRR 0034 LD 6	30
		Heavy duty	BRR 0034 HD 6	30
	0052-0062	Light duty	BRR 0052 LD 6	18
		Heavy duty	BRR 0052 HD 6	18
MR8	0080	Light duty	BRR 0052 LD 6	18
		Heavy duty	BRR 0052 HD 6	18
	0100-0125	Light duty	BRR 0100 LD 6	9
		Heavy duty	BRR 0100 HD 6	9
MR9	0144	Light duty	BRR 0100 LD 6	9
		Heavy duty	BRR 0100 HD 6	9
	0170-0208	Light duty	BRR 0208 LD 6	7
		Heavy duty	BRR 0208 HD 6	7

- The light duty cycle is for brake resistor cyclic use (1 LD pulse in a 120-second period). The light duty resistor is rated for a 5-second ramp from full power to 0.
- The heavy duty cycle is for brake resistor cyclic use (1 HD pulse in a 120-second period). The heavy duty resistor is rated for a 3-second full power braking with a 7-second ramp to 0.

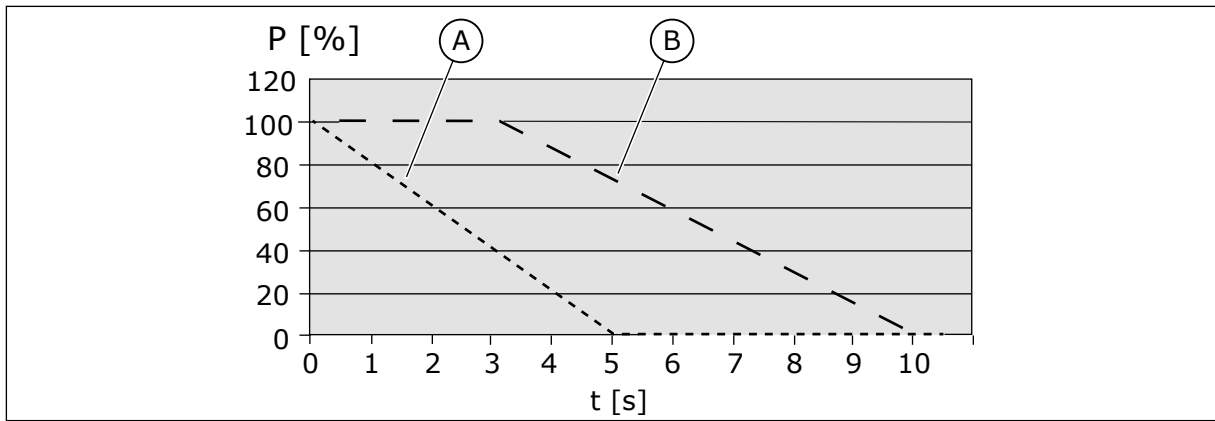

Fig. 48: The LD and HD pulses, P = brake power

A. Light duty (LD)

B. Heavy duty (HD)

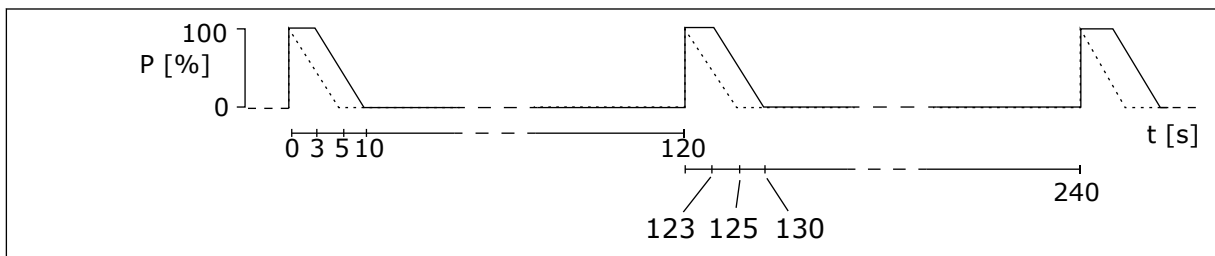

Fig. 49: The duty cycles of the LD and HD pulses

Table 40: The minimum resistance and the brake power, mains voltage 208-240 V

Frame	The minimum brake resistance [Ω]	Brake power* @405 VDC [kW]
MR4	30.0	2.6
MR5	20.0	3.9
MR6	10.0	7.8
MR7	5.5	11.7
MR8	3.0	25.2
MR9	1.4	49.7

* = When you use recommended resistor types.

Table 41: The minimum resistance and the brake power, mains voltage 380-500 V

Frame	The minimum brake resistance [Ω]	Brake power* @845 VDC [kW]
MR4	63.0	11.3
MR5	41.0	17.0
MR6	21.0	34.0
MR7	14.0	51.0
MR8	6.5	109.9
MR9	3.3	216.4

* = When you use recommended resistor types.

Table 42: The minimum resistance and the brake power, mains voltage 525-600 V

Frame	The minimum brake resistance [Ω]	Brake power* @1014 VDC [kW]
MR5	100	7.5
MR6	30	22.4
MR7	18	44.8
MR8	9	93.3
MR9	7	145

* = When you use recommended resistor types.

Table 43: The minimum resistance and the brake power, mains voltage 525-690 V

Frame	The minimum brake resistance [Ω]	Brake power* @1166 VDC [kW]
MR6	30	30
MR7	18	55
MR8	9	110
MR9	7	193

* = When you use recommended resistor types.

8.2 VACON® 100 - TECHNICAL DATA

Table 44: The technical data of the Vacon® 100 AC drive

Technical item or function		Technical data
Mains connection	Input voltage U_{in}	208-240 V, 380-500 V, 525-600 V, 525-690 V, -10%...+10%
	Input frequency	50-60 Hz, -5...+10%
	Connection to mains	Once per minute or less
	Starting delay	6 s (MR4 to MR6), 8 s (MR7 to MR9)
	Mains	<ul style="list-style-type: none"> Mains types: TN, TT, and IT Short circuit current: the maximum short circuit current must be < 100 kA.
Motor connection	Output voltage	0- U_{in}
	Continuous output current	IL: Ambient temperature max. +40 °C overload 1.1 x IL (1 min/10 min) IH: Ambient temperature max. +50 °C overload 1.5 x IH (1 min/10 min) IH in 600/690 V drives: Ambient temperature max. +40 °C overload 1.5 x IH (1 min/10 min)
	Output frequency	0-320 Hz (standard)
	Frequency resolution	0.01 Hz

Table 44: The technical data of the Vacon® 100 AC drive

Technical item or function	Technical data
Control characteristics	<p>Switching frequency (see parameter P3.1.2.3)</p> <p>200-500 V</p> <ul style="list-style-type: none"> • MR4-MR6: <ul style="list-style-type: none"> • 1.5-10 kHz • Default: 6 kHz (except for 0012 2, 0031 2, 0062 2, 0012 5, 0031 5 and 0061 5: 4 kHz) • MR7-MR9: <ul style="list-style-type: none"> • 1.5-6 kHz • Default: MR7: 4 kHz, MR8: 3 kHz, MR9: 2 kHz <p>600-690 V</p> <ul style="list-style-type: none"> • MR5-MR9: <ul style="list-style-type: none"> • 1.5-6 kHz • Default: 2 kHz • For a product that is configured for a C4 installation on IT network the maximum switching frequency is limited to default 2kHz. <p>Automatic switching frequency derating in case of overload.</p>
Frequency reference:	<p>Resolution 0.1% (10-bit), accuracy ±1%</p> <p>Resolution 0.01 Hz</p>
• Analogue input • Panel reference	
Field weakening point	8-320 Hz
Acceleration time	0.1-3000 s
Deceleration time	0.1-3000 s

Table 44: The technical data of the Vacon® 100 AC drive

Technical item or function	Technical data	
Ambient conditions	Ambient operating temperature	IL current: -10°C (no frost)...+40 °C IH current: -10°C (no frost)...+50 °C Maximum operating temperature: +50 °C
	Storage temperature	-40 °C...+70 °C
	Relative humidity	0-95% RH, non-condensing, non-corrosive
	Air quality: <ul style="list-style-type: none">• chemical vapours• mechanical particles	Tested according to IEC 60068-2-60 Test Ke: Flowing mixed gas corrosion test, Method 1 (H ₂ S [hydrogen sulfide] and SO ₂ [sulfur dioxide]) Designed according to <ul style="list-style-type: none">• IEC 60721-3-3, unit in operation, class 3C3 (IP21/UL Type 1 Models 3C2)• IEC 60721-3-3, unit in operation, class 3S2
	Altitude	100% nominal rating (no derating) up to 1000 m 1% derating for each 100m above 1000 m Maximum altitudes: <ul style="list-style-type: none">• 208-240 V: 4000 m (TN and IT systems)• 380-500 V: 4000 m (TN and IT systems)• 380-500 V: 2000 m (corner-grounded network)• 525-690 V: 2000 m (TN and IT systems, no corner grounding) Voltage for relay outputs: <ul style="list-style-type: none">• Up to 3000 m: Allowed up to 240 V• 3000-4000 m: Allowed up to 120 V Corner grounding is allowed for MR4-MR6 (main voltage 208-230 V) up to 2000 m (see chapter 5.7 <i>Installation in a corner-grounded network</i>).

Table 44: The technical data of the Vacon® 100 AC drive

Technical item or function	Technical data	
Ambient conditions	Vibration: <ul style="list-style-type: none"> • EN 61800-5-1 • EN 60068-2-6 	5-150 Hz Displacement amplitude 1 mm (peak) at 5-15.8 Hz (MR4-MR9) Maximum acceleration amplitude 1 G at 15.8-150 Hz (MR4-MR9)
	Shock: <ul style="list-style-type: none"> • EN 60068-2-27 	UPS Drop Test (for applicable UPS weights) Storage and shipping: maximum 15 G, 11 ms (in package)
	Enclosure class	IP21/UL Type 1: standard in entire kW/HP range IP54/UL Type 12: option NOTE! For IP54/Type 12, a control panel adapter is necessary.
EMC (at default settings)	Immunity	Fulfils EN 61800-3 (2004), 1st and 2nd environment
	Emissions	<ul style="list-style-type: none"> • 200-500 V: EN 61800-3 (2004), category C2. • 600-690 V: EN 61800-3 (2004), category C3. • All: The product is configurable to category C4 for installation on IT networks. The drive can be modified for IT type mains. See chapter 7.6 <i>Installation in an IT system</i>. The IP00 / UL Open Type drive has by default category C4.
Noise level	Average noise level (min-max) sound pressure level in dB(A)	The sound pressure depends on the cooling fan speed, which is controlled in accordance with the drive temperature. MR4: 45-56 MR5: 57-65 MR6: 63-72 MR7: 43-73 MR8: 58-73 MR9: 54-75
Safety standards and certifications	EN 61800-5-1 (2007), CE, cUL (See the nameplate of the drive for more approvals.)	

Table 44: The technical data of the Vacon® 100 AC drive

Technical item or function		Technical data
Protections	Overvoltage trip limit	Mains voltage 240 V: 456 VDC Mains voltage 500 V: 911 VDC Mains voltage 600 V: 1094 VDC Mains voltage 690 V: 1258 VDC
	Undervoltage trip limit	Depends on mains voltage (0.8775 x mains voltage): Mains voltage 240 V: trip limit 211 VDC Mains voltage 400 V: trip limit 351 VDC Mains voltage 500 V: trip limit 438 VDC Mains voltage 525 V: trip limit 461 VDC Mains voltage 600 V: trip limit 527 VDC Mains voltage 690 V: trip limit 606 VDC
	Earth fault protection	Yes
	Mains supervision	Yes
	Motor phase supervision	Yes
	Overcurrent protection	Yes
	Unit overtemperature protection	Yes
	Motor overload protection	Yes. * The motor overload protection activates at 110% of the full load current.
	Motor stall protection	Yes
	Motor underload protection	Yes
Short-circuit protection of +24 V and +10 V reference voltages	Yes	

* = For the motor thermal memory and the memory retention function to obey the UL 61800-5-1 requirements, you must use the system software version FW0072V007 or a newer version. If you use an older system software version, you must install a motor overtemperature protection to obey the UL regulations.

9 TECHNICAL DATA, VACON® 100 FLOW

9.1 AC DRIVE POWER RATINGS

9.1.1 MAINS VOLTAGE 208-240 V

Table 45: The power ratings of Vacon® 100 FLOW in mains voltage 208-240 V, 50-60 Hz, 3~

Frame	Drive type	Loadability *				Motor shaft power	
		Continuous current I _L [A]	Input current I _{in} [A]	10% overload current [A]	Max current I _S 2s	230 V mains	230 V mains
						10% overload 40°C [kW]	10% overload 40°C [hp]
MR4	0003	3.7	3.2	4.1	5.2	0.55	0.75
	0004	4.8	4.2	5.3	7.4	0.75	1.0
	0007	6.6	6.0	7.3	9.6	1.1	1.5
	0008	8.0	7.2	8.8	13.2	1.5	2.0
	0011	11.0	9.7	12.1	16.0	2.2	3.0
	0012	12.5	10.9	13.8	19.6	3.0	4.0
MR5	0018	18.0	16.1	19.8	25.0	4.0	5.0
	0024	24.0	21.7	26.4	36.0	5.5	7.5
	0031	31.0	27.7	34.1	46.0	7.5	10.0
MR6	0048	48.0	43.8	52.8	62.0	11.0	15.0
	0062	62.0	57.0	68.2	96.0	15.0	20.0
MR7	0075	75.0	69.0	82.5	124.0	18.5	25.0
	0088	88.0	82.1	96.8	150.0	22.0	30.0
	0105	105.0	99.0	115.5	176.0	30.0	40.0
MR8	0140	143.0	135.1	154.0	210.0	37.0	50.0
	0170	170.0	162.0	187.0	280.0	45.0	60.0
	0205	208.0	200.0	225.5	340.0	55.0	75.0
MR9	0261	261.0	253.0	287.1	410.0	75.0	100.0
	0310	310.0	301.0	341.0	502.0	90.0	125.0

* = See chapter 9.1.5 Overload capability.

**NOTE!**

The currents in given ambient temperatures (in chapter 9.2 *Vacon® 100 FLOW - technical data*) are achieved only when the switching frequency is equal to or less than the factory default.

If your process includes a cyclical load, for example if there are lifts or winches, speak to the manufacturer to get the dimensioning information.

9.1.2 MAINS VOLTAGE 380-500 V

Table 46: The power ratings of Vacon® 100 FLOW in mains voltage 380-500 V, 50-60 Hz, 3~

Frame	Drive type	Loadability *				Motor shaft power	
		Continuous current I _L [A]	Input current I _{in} [A]	10% overload current [A]	Max current I _S 2s	400 V mains	480 V mains
						10% overload 40°C [kW]	10% overload 40°C [hp]
MR4	0003	3.4	3.4	3.7	5.2	1.1	1.5
	0004	4.8	4.6	5.3	6.8	1.5	2.0
	0005	5.6	5.4	6.2	8.6	2.2	3.0
	0008	8.0	8.1	8.8	11.2	3.0	4.0
	0009	9.6	9.3	10.6	16.0	4.0	5.0
	0012	12.0	11.3	13.2	19.2	5.5	7.5
MR5	0016	16.0	15.4	17.6	24.0	7.5	10.0
	0023	23.0	21.3	25.3	32.0	11.0	15.0
	0031	31.0	28.4	34.1	46.0	15.0	20.0
MR6	0038	38.0	36.7	41.8	62.0	18.5	25.0
	0046	46.0	43.6	50.6	76.0	22.0	30.0
	0061	61.0	58.2	67.1	92.0	30.0	40.0
MR7	0072	72.0	67.5	79.2	122.0	37.0	50.0
	0087	87.0	85.3	95.7	144.0	45.0	60.0
	0105	105.0	100.6	115.5	174.0	55.0	75.0
MR8	0140	140.0	139.4	154.0	210.0	75.0	100.0
	0170	170.0	166.5	187.0	280.0	90.0	125.0
	0205	205.0	199.6	225.5	340.0	110.0	150.0
MR9	0261	261.0	258.0	287.1	410.0	132.0	200.0
	0310	310.0	303.0	341.0	502.0	160.0	250.0

* = See chapter 9.1.5 Overload capability.

**NOTE!**

The currents in given ambient temperatures (in chapter 9.2 *Vacon® 100 FLOW - technical data*) are achieved only when the switching frequency is equal to or less than the factory default.

If your process includes a cyclical load, for example if there are lifts or winches, speak to the manufacturer to get the dimensioning information.

9.1.3 MAINS VOLTAGE 525-600 V

Table 47: The power ratings of Vacon® 100 FLOW in mains voltage 525-600 V, 50-60 Hz, 3~

Frame	Drive type	Loadability				Motor shaft power
		Continuous current I_L [A]	Input current I_{in} [A]	10% overload current [A]	Max continuous current I_S 2s	600 V
						10% overload 40°C [Hp]
MR5	0004	3.9	4.6	4.3	5.4	3.0
	0006	6.1	6.8	6.7	7.8	5.0
	0009	9.0	9.0	9.9	12.2	7.5
	0011	11.0	10.5	12.1	18.0	10.0
MR6	0018	18.0	19.9	19.8	27.0	15.0
	0022	22.0	23.3	24.2	36.0	20.0
	0027	27.0	27.2	29.7	44.0	25.0
	0034	34.0	32.8	37.4	54.0	30.0
MR7	0041	41.0	45.3	45.1	68.0	40.0
	0052	52.0	53.8	57.2	82.0	50.0
	0062	62.0	62.2	68.2	104.0	60.0
MR8	0080	80.0	90.0	88.0	124.0	75.0
	0100	100.0	106.0	110.0	160.0	100.0
	0125	125.0	127.0	137.5	200.0	125.0
MR9	0144	144.0	156.0	158.4	250.0	150.0
	0208	208.0	212.0	228.8	340.0	200.0

9.1.4 MAINS VOLTAGE 525-690 V

Table 48: The power ratings of Vacon® 100 FLOW in mains voltage 525-690 V, 50-60 Hz, 3~

Frame	Drive type	Loadability				Motor shaft power	
		Continuous current I _L [A]	Input current I _{in} [A]	10% overload current [A]	Max continuous current I _S 2s	600 V	690 V
						10% overload 40°C [Hp]	10% overload 40°C [kW]
MR6	0007	7.5	6.8	8.3	11.0	5.0	5.5
	0010	10.0	9.0	11.0	15.0	7.5	7.5
	0013	13.5	11.6	14.9	20.0	10.0	11.0
	0018	18.0	15.2	19.8	27.0	15.0	15.0
	0022	22.0	19.8	24.2	36.0	20.0	18.5
	0027	27.0	23.1	29.7	44.0	25.0	22.0
	0034	34.0	27.0	37.4	54.0	30.0	30.0
MR7	0041	41.0	38.4	45.1	68.0	40.0	37.0
	0052	52.0	44.9	57.2	82.0	50.0	45.0
	0062	62.0	53.2	68.2	104.0	60.0	55.0
MR8	0080	80.0	72.0	88.0	124.0	75.0	75.0
	0100	100.0	89.0	110.0	160.0	100.0	90.0
	0125	125.0	104.0	137.5	200.0	125.0	110.0
MR9	0144	144.0	140.0	158.4	250.0	150.0	132.0
	0170	170.0	155.0	187.0	288.0	150.0	160.0
	0208	208.0	177.0	228.8	340.0	200.0	200.0

9.1.5 OVERLOAD CAPABILITY

The **low overload** means that if 110% of the continuous current (I_L) is required for 1 minute every 10 minutes, the remaining 9 minutes must be approximately 98% of I_L or less. This is to make sure that the output current is not more than I_L during the duty cycle.

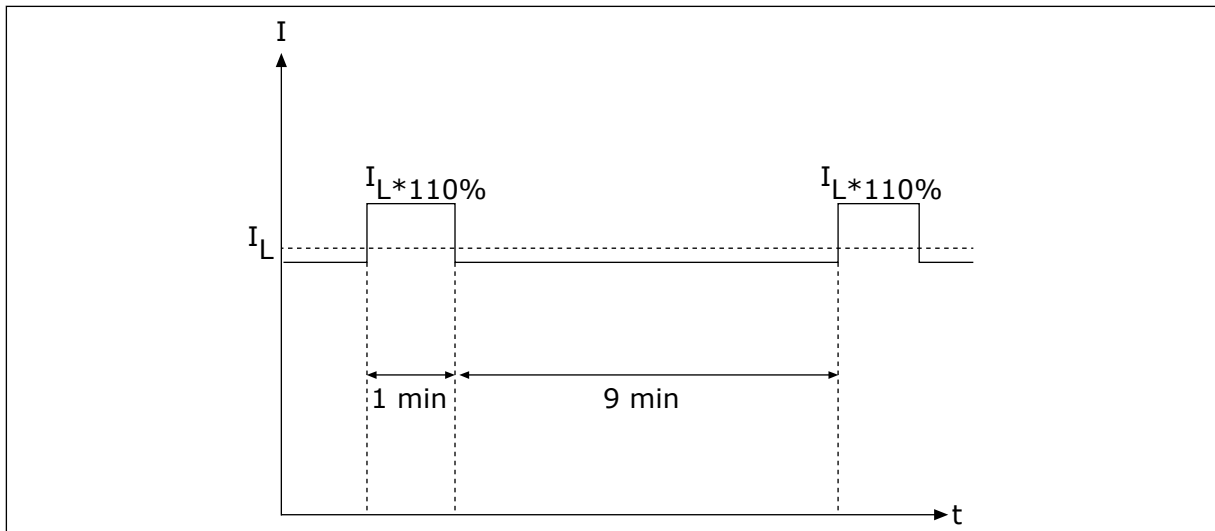

Fig. 50: Low overload in Vacon® 100 FLOW

For more information, refer to the standard IEC61800-2 (IEC:1998).

9.2 VACON® 100 FLOW - TECHNICAL DATA

Table 49: The technical data of the Vacon® 100 FLOW AC drive

Technical item or function		Technical data
Mains connection	Input voltage U_{in}	208-240 V, 380-500 V, 525-600 V, 525-690 V, -10%...+10%
	Input frequency	50-60 Hz, -5...+10%
	Connection to mains	Once per minute or less
	Starting delay	6 s (MR4 to MR6); 8 s (MR7 to MR9)
	Mains	<ul style="list-style-type: none"> • Mains types: TN, TT, and IT • Short circuit current: the maximum short circuit current must be < 100 kA.
Motor connection	Output voltage	0- U_{in}
	Continuous output current	I_L : Ambient temperature max. +40 °C overload 1.1 x I_L (1 min/10 min)
	Output frequency	0-320 Hz (standard)
	Frequency resolution	0.01 Hz

Table 49: The technical data of the Vacon® 100 FLOW AC drive

Technical item or function	Technical data
Control characteristics	<p>Switching frequency (see parameter P3.1.2.3)</p> <p>200-500 V</p> <ul style="list-style-type: none"> • MR4-MR6: <ul style="list-style-type: none"> • 1.5-10 kHz • Default: 6 kHz (except for 0012 2, 0031 2, 0062 2, 0012 5, 0031 5 and 0061 5: 4 kHz) • MR7-MR9: <ul style="list-style-type: none"> • 1.5-6 kHz • Default: MR7: 4 kHz, MR8: 3 kHz, MR9: 2 kHz <p>600-690 V</p> <ul style="list-style-type: none"> • MR5-MR9: <ul style="list-style-type: none"> • 1.5-6 kHz • Default: 2 kHz • For a product that is configured for a C4 installation on IT network the maximum switching frequency is limited to default 2kHz. <p>Automatic switching frequency derating in case of overload.</p>
Frequency reference:	<ul style="list-style-type: none"> • Analogue input • Panel reference <p>Resolution 0.1% (10-bit), accuracy ±1% Resolution 0.01 Hz</p>
Field weakening point	8-320 Hz
Acceleration time	0.1-3000 s
Deceleration time	0.1-3000 s

Table 49: The technical data of the Vacon® 100 FLOW AC drive

Technical item or function	Technical data
Ambient conditions	Ambient operating temperature IL current: -10°C (no frost)...+40 °C Up to 50 °C with derating (1.5%/1°C)
	Storage temperature -40 °C...+70 °C
	Relative humidity 0-95% RH, non-condensing, non-corrosive
	Air quality: <ul style="list-style-type: none"> • chemical vapours • mechanical particles Tested according to IEC 60068-2-60 Test Ke: Flowing mixed gas corrosion test, Method 1 (H ₂ S [hydrogen sulfide] and SO ₂ [sulfur dioxide]) Designed according to: <ul style="list-style-type: none"> • IEC 60721-3-3, unit in operation, class 3C3 (IP21/UL Type 1 Models 3C2) • IEC 60721-3-3, unit in operation, class 3S2
	Altitude 100% nominal rating (no derating) up to 1000 m 1% derating for each 100m above 1000 m Maximum altitudes: <ul style="list-style-type: none"> • 208-240 V: 4000 m (TN and IT systems) • 380-500 V: 4000 m (TN and IT systems) • 380-500 V: 2000 m (corner-grounded network) • 525-690 V: 2000 m (TN and IT systems, no corner grounding) Voltage for relay outputs: <ul style="list-style-type: none"> • Up to 3000 m : Allowed up to 240 V • 3000 m-4000 m: Allowed up to 120 V Corner grounding is allowed for MR4-MR6 (main voltage 208-230 V) up to 2000 m (see chapter 5.7 <i>Installation in a corner-grounded network</i>)

Table 49: The technical data of the Vacon® 100 FLOW AC drive

Technical item or function	Technical data	
Ambient conditions	Vibration: <ul style="list-style-type: none"> • EN 61800-5-1 • EN 60068-2-6 	5-150 Hz Displacement amplitude 1 mm (peak) at 5-15.8 Hz (MR4-MR9) Maximum acceleration amplitude 1 G at 15.8-150 Hz (MR4-MR9)
	Shock: <ul style="list-style-type: none"> • EN 60068-2-27 	UPS Drop Test (for applicable UPS weights) Storage and shipping: maximum 15 G, 11 ms (in package)
	Enclosure class	IP21/UL Type 1: standard in entire kW/HP range IP54/UL Type 12: option NOTE! For IP54/Type 12, a control panel adapter is necessary.
EMC (at default settings)	Immunity	Fulfils EN 61800-3 (2004), 1st and 2nd environment
	Emissions	<ul style="list-style-type: none"> • 200-500 V: EN 61800-3 (2004), category C2. • 600-690 V: EN 61800-3 (2004), category C3. • All: The product is configurable to category C4 for installation on IT networks. The drive can be modified for IT type mains. See chapter 7.6 <i>Installation in an IT system</i>. The IP00 / UL Open Type drive has by default category C4.
Noise level	Average noise level (min-max) sound pressure level in dB(A)	The sound pressure depends on the cooling fan speed, which is controlled in accordance with the drive temperature. MR4: 45-56 MR5: 53-65 MR6: 62-72 MR7: 43-73 MR8: 58-73 MR9: 54-75
Safety standards and certifications	EN 61800-5-1 (2007), CE, cUL (See the nameplate of the drive for more approvals.)	

Table 49: The technical data of the Vacon® 100 FLOW AC drive

Technical item or function		Technical data
Protections	Overvoltage trip limit	Mains voltage 240 V: 456 VDC Mains voltage 500 V: 911 VDC Mains voltage 600 V: 1094 VDC Mains voltage 690 V: 1258 VDC
	Undervoltage trip limit	Depends on mains voltage (0.8775 x mains voltage): Mains voltage 240 V: trip limit 211 VDC Mains voltage 400 V: trip limit 351 VDC Mains voltage 500 V: trip limit 438 VDC Mains voltage 525 V: trip limit 461 VDC Mains voltage 600 V: trip limit 527 VDC Mains voltage 690 V: trip limit 606 VDC
	Earth fault protection	Yes
	Mains supervision	Yes
	Motor phase supervision	Yes
	Overcurrent protection	Yes
	Unit overtemperature protection	Yes
	Motor overload protection	Yes. * The motor overload protection activates at 110% of the full load current.
	Motor stall protection	Yes
	Motor underload protection	Yes
Short-circuit protection of +24 V and +10 V reference voltages	Yes	

* = For the motor thermal memory and the memory retention function to obey the UL 61800-5-1 requirements, you must use the system software version FW0072V007 or a newer version. If you use an older system software version, you must install a motor overtemperature protection to obey the UL regulations.

10 TECHNICAL DATA, VACON® 100 HVAC

10.1 AC DRIVE POWER RATINGS

10.1.1 MAINS VOLTAGE 208-240 V

Table 50: The power ratings of Vacon® 100 HVAC in mains voltage 208-240 V, 50-60 Hz, 3~

Frame	Drive type	Loadability			Motor shaft power	
		Low*			230 V mains	208-240 V mains
		Continuous current I _L [A]	Input current I _{in} [A]	10% overload current [A]	10% overload 40°C [kW]	10% overload 40°C [Hp]
MR4	0003	3.7	3.2	4.1	0.55	0.75
	0004	4.8	4.2	5.3	0.75	1.0
	0006	6.6	6.0	7.3	1.1	1.5
	0008	8.0	7.2	8.8	1.5	2.0
	0011	11.0	9.7	12.1	2.2	3.0
	0012	12.5	10.9	13.8	3.0	4.0
MR5	0018	18.0	16.1	19.8	4.0	5.0
	0024	24.2	21.7	26.4	5.5	7.5
	0031	31.0	27.7	34.1	7.5	10.0
MR6	0048	48.0	43.8	52.8	11.0	15.0
	0062	62.0	57.0	68.2	15.0	20.0
MR7	0075	75.0	69.0	82.5	18.5	25.0
	0088	88.0	82.1	96.8	22.0	30.0
	0105	105.0	99.0	115.5	30.0	40.0
MR8	0140	143.0	135.1	154.0	37.0	50.0
	0170	170.0	162.0	187.0	45.0	60.0
	0205	208.0	200.0	225.5	55.0	75.0
MR9	0261	261.0	253.0	287.1	75.0	100.0
	0310	310.0	301.0	341.0	90.0	125.0

*See 10.1.4 Overload capability.

**NOTE!**

The currents in given ambient temperatures (in chapter 10.2 Vacon® 100 HVAC - technical data) are achieved only when the switching frequency is equal to or less than the factory default.

10.1.2 MAINS VOLTAGE 380-500 V

Table 51: The power ratings of Vacon® 100 HVAC in mains voltage 380-500 V, 50-60 Hz, 3~

Frame	Drive type	Loadability			Motor shaft power	
		Low*			400 V mains	480 V mains
		Continuous current I _L [A]	Input current I _{in} [A]	10% overload current [A]	10% overload 40°C [kW]	10% overload 40°C [Hp]
MR4	0003	3.4	3.4	3.7	1.1	1.5
	0004	4.8	4.6	5.3	1.5	2.0
	0005	5.6	5.4	6.2	2.2	3.0
	0008	8.0	8.1	8.8	3.0	5.0
	0009	9.6	9.3	10.6	4.0	5.0
	0012	12.0	11.3	13.2	5.5	7.5
MR5	0016	16.0	15.4	17.6	7.5	10.0
	0023	23.0	21.3	25.3	11.0	15.0
	0031	31.0	28.4	34.1	15.0	20.0
MR6	0038	38.0	36.7	41.8	18.5	25.0
	0046	46.0	43.6	50.6	22.0	30.0
	0061	61.0	58.2	67.1	30.0	40.0
MR7	0072	72.0	67.5	79.2	37.0	50.0
	0087	87.0	85.3	95.7	45.0	60.0
	0105	105.0	100.6	115.5	55.0	75.0
MR8	0140	140.0	139.4	154.0	75.0	100.0
	0170	170.0	166.5	187.0	90.0	125.0
	0205	205.0	199.6	225.5	110.0	150.0
MR9	0261	261.0	258.0	287.1	132.0	200.0
	0310	310.0	303.0	341.0	160.0	250.0

See 10.1.4 Overload capability.

**NOTE!**

The currents in given ambient temperatures (in chapter 10.2 Vacon® 100 HVAC - technical data) are achieved only when the switching frequency is equal to or less than the factory default.

10.1.3 MAINS VOLTAGE 525-600 V**Table 52: The power ratings of Vacon® 100 HVAC in mains voltage 525-600 V, 50-60 Hz, 3~**

Frame	Drive type	Loadability				Motor shaft power
		Continuous current I_L [A]	Input current I_{in} [A]	10% overload current [A]	Max continuous current I_S 2s	600 V
						10% overload 40°C [Hp]
MR5	0004	3.9	4.6	4.3	5.4	3.0
	0006	6.1	6.8	6.7	7.8	5.0
	0009	9.0	9.0	9.9	12.2	7.5
	0011	11.0	10.5	12.1	18.0	10.0
MR6	0018	18.0	19.9	19.8	27.0	15.0
	0022	22.0	23.3	24.2	36.0	20.0
	0027	27.0	27.2	29.7	44.0	25.0
	0034	34.0	32.8	37.4	54.0	30.0
MR7	0041	41.0	45.3	45.1	68.0	40.0
	0052	52.0	53.8	57.2	82.0	50.0
	0062	62.0	62.2	68.2	104.0	60.0
MR8	0080	80.0	90.0	88.0	124.0	75.0
	0100	100.0	106.0	110.0	160.0	100.0
	0125	125.0	127.0	137.5	200.0	125.0
MR9	0144	144.0	156.0	158.4	250.0	150.0
	0208	208.0	212.0	228.8	340.0	200.0

10.1.4 OVERLOAD CAPABILITY

The **low overload** means that if 110% of the continuous current (I_L) is required for 1 minute every 10 minutes, the remaining 9 minutes must be approximately 98% of I_L or less. This is to make sure that the output current is not more than I_L during the duty cycle.

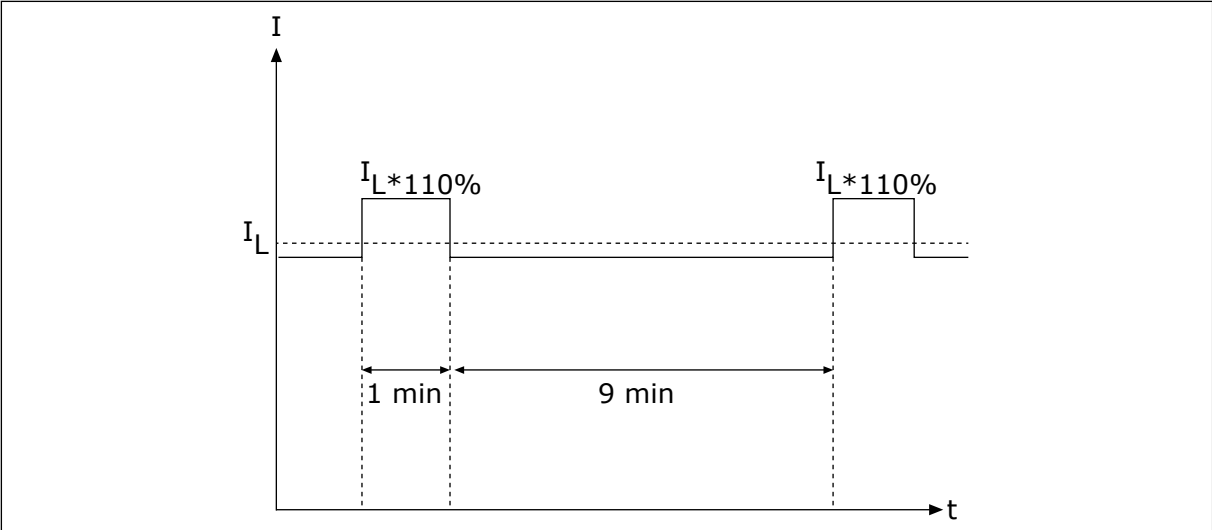

Fig. 51: Low overload in Vacon® 100 HVAC

For more information, refer to the standard IEC61800-2 (IEC:1998).

10.2 VACON® 100 HVAC - TECHNICAL DATA

Table 53: The technical data of the Vacon® 100 HVAC AC drive

Technical item or function		Technical data
Mains connection	Input voltage U_{in}	208-240 V, 380-500 V, 525-600 V, -10%...+10%
	Input frequency	50-60 Hz, -5...+10%
	Connection to mains	Once per minute or less
	Starting delay	6 s (MR4 to MR6); 8 s (MR7 to MR9)
	Mains	<ul style="list-style-type: none"> • Mains types: TN, TT, and IT • Short circuit current: the maximum short circuit current must be < 100 kA.
Motor connection	Output voltage	0- U_{in}
	Continuous output current	I_L : Ambient temperature max. +40 °C overload 1.1 x I_L (1 min/10 min)
	Output frequency	0-320 Hz (standard)
	Frequency resolution	0.01 Hz

Table 53: The technical data of the Vacon® 100 HVAC AC drive

Technical item or function	Technical data
Control characteristics	<p>Switching frequency (see parameter P3.1.2.3)</p> <p>200-500 V</p> <ul style="list-style-type: none"> • MR4-MR6: <ul style="list-style-type: none"> • 1.5-10 kHz • Default: 6 kHz (except for 0012 2, 0031 2, 0062 2, 0012 5, 0031 5 and 0061 5: 4 kHz) • MR7-MR9: <ul style="list-style-type: none"> • 1.5-6 kHz • Default: MR7: 4 kHz, MR8: 3 kHz, MR9: 2 kHz <p>600 V</p> <ul style="list-style-type: none"> • MR5-MR9: <ul style="list-style-type: none"> • 1.5-6 kHz • Default: 2 kHz • For a product that is configured for a C4 installation on IT network the maximum switching frequency is limited to default 2kHz. <p>Automatic switching frequency derating in case of overload.</p>
Frequency reference:	<p>Resolution 0.1% (10-bit), accuracy ±1%</p> <p>Resolution 0.01 Hz</p>
• Analogue input • Panel reference	
Field weakening point	8-320 Hz
Acceleration time	0.1-3000 s
Deceleration time	0.1-3000 s

Table 53: The technical data of the Vacon® 100 HVAC AC drive

Technical item or function	Technical data
Ambient conditions	Ambient operating temperature IL current: -10°C (no frost)...+40 °C Up to 50 °C with derating (1.5%/1°C)
	Storage temperature -40 °C...+70 °C
	Relative humidity 0-95% RH, non-condensing, non-corrosive
	Air quality: <ul style="list-style-type: none"> • chemical vapours • mechanical particles Tested according to IEC 60068-2-60 Test Ke: Flowing mixed gas corrosion test, Method 1 (H ₂ S [hydrogen sulfide] and SO ₂ [sulfur dioxide]) Designed according to: <ul style="list-style-type: none"> • IEC 60721-3-3, unit in operation, class 3C2 • IEC 60721-3-3, unit in operation, class 3S2
	Altitude 100% nominal rating (no derating) up to 1000 m 1% derating for each 100m above 1000 m Maximum altitudes: <ul style="list-style-type: none"> • 208-240 V: 4000 m (TN and IT systems) • 380-500 V: 4000 m (TN and IT systems) • 380-500 V: 2000 m (corner-grounded network) • 525-600 V: 2000 m (TN and IT systems, no corner grounding) Voltage for relay outputs: <ul style="list-style-type: none"> • Up to 3000 m : Allowed up to 240 V • 3000 m-4000 m: Allowed up to 120 V Corner grounding is allowed for MR4-MR6 (main voltage 208-230 V) up to 2000 m (see chapter 5.7 <i>Installation in a corner-grounded network</i>)
Ambient conditions	Vibration: <ul style="list-style-type: none"> • EN 61800-5-1 • EN 60068-2-6 5-150 Hz Displacement amplitude 1 mm (peak) at 5-15.8 Hz (MR4-MR9) Maximum acceleration amplitude 1 G at 15.8-150 Hz (MR4-MR9)
	Shock: <ul style="list-style-type: none"> • EN 60068-2-27 UPS Drop Test (for applicable UPS weights) Storage and shipping: maximum 15 G, 11 ms (in package)
	Enclosure class IP21/UL Type 1: standard in entire kW/HP range IP54/UL Type 12: option NOTE! For IP54/Type 12, a control panel adapter is necessary.

Table 53: The technical data of the Vacon® 100 HVAC AC drive

Technical item or function		Technical data
EMC (at default settings)	Immunity	Fulfils EN 61800-3 (2004), 1st and 2nd environment
	Emissions	<ul style="list-style-type: none"> • 200-500 V: EN 61800-3 (2004), category C2. • 600 V: EN 61800-3 (2004), category C3. • All: The product is configurable to category C4 for installation on IT networks. The drive can be modified for IT type mains. See chapter 7.6 <i>Installation in an IT system</i>. The IP00 / UL Open Type drive has by default category C4.
Noise level	Average noise level (min-max) sound pressure level in dB(A)	<p>The sound pressure depends on the cooling fan speed, which is controlled in accordance with the drive temperature.</p> <p>MR4: 45-56 MR5: 53-65 MR6: 62-72 MR7: 43-73 MR8: 58-73 MR9: 54-75</p>
Safety standards and certifications		EN 61800-5-1 (2007), CE, cUL (See the nameplate of the drive for more approvals.)

Table 53: The technical data of the Vacon® 100 HVAC AC drive

Technical item or function	Technical data	
Protections	Overvoltage trip limit	Mains voltage 240 V: 456 VDC Mains voltage 500 V: 911 VDC Mains voltage 600 V: 1094 VDC
	Undervoltage trip limit	Depends on mains voltage (0.8775 x mains voltage): Mains voltage 240 V: trip limit 211 VDC Mains voltage 400 V: trip limit 351 VDC Mains voltage 500 V: trip limit 438 VDC Mains voltage 525 V: trip limit 461 VDC Mains voltage 600 V: trip limit 527 VDC
	Earth fault protection	Yes
	Mains supervision	Yes
	Motor phase supervision	Yes
	Overcurrent protection	Yes
	Unit overtemperature protection	Yes
	Motor overload protection	Yes. * The motor overload protection activates at 110% of the full load current.
	Motor stall protection	Yes
	Motor underload protection	Yes
	Short-circuit protection of +24 V and +10 V reference voltages	Yes

* = For the motor thermal memory and the memory retention function to obey the UL 61800-5-1 requirements, you must use the system software version FW0072V007 or a newer version. If you use an older system software version, you must install a motor overtemperature protection to obey the UL regulations.

11 TECHNICAL DATA ON CONTROL CONNECTIONS

11.1 TECHNICAL DATA ON CONTROL CONNECTIONS

Table 54: The standard I/O board

Standard I/O board		
Terminal	Signal	Technical information
1	Reference output	+10 V, +3%, maximum current: 10 mA
2	Analogue input, voltage or current	Analogue input channel 1 0...+10 V (R _i = 200 kΩ) 4-20 mA (R _i =250 Ω) Resolution 0.1 %, accuracy ±1 % Selection V/mA with dip-switches (see chapter 6.2.2.1 <i>Selection of terminal functions with DIP switches</i>)
3	Analogue input common (current)	Differential input if not connected to ground Allows ±20 V common mode voltage to GND
4	Analogue input, voltage or current	Analogue input channel 2 Default: 4-20 mA (R _i =250 Ω) 0-10 V (R _i =200 kΩ) Resolution 0.1 %, accuracy ±1 % Selection V/mA with dip-switches (see chapter 6.2.2.1 <i>Selection of terminal functions with DIP switches</i>)
5	Analogue input common (current)	Differential input if not connected to ground Allows ±20 V common mode voltage to GND
6	24 V aux. voltage	+24 V, ±10%, max volt. ripple < 100 mVrms max. 250 mA Short-circuit protected
7	I/O ground	Ground for reference and controls (connected internally to frame ground through 1 MΩ)
8	Digital input 1	Positive or negative logic R _i = min. 5 kΩ 0-5 V = 0 15-30 V = 1
9	Digital input 2	
10	Digital input 3	
11	Common A for DIN1-DIN6	Digital inputs can be disconnected from ground, see chapter 6.2.2.2 <i>Isolation of digital inputs from ground.</i>

Table 54: The standard I/O board

Standard I/O board		
Terminal	Signal	Technical information
12	24 V aux. voltage	+24 V, $\pm 10\%$, max volt. ripple < 100mVrms max. 250 mA Short-circuit protected
13	I/O ground	Ground for reference and controls (connected internally to frame ground through 1 M Ω)
14	Digital input 4	Positive or negative logic R _i = min. 5 k Ω 0-5 V = 0 15-30 V = 1
15	Digital input 5	
16	Digital input 6	
17	Common A for DIN1-DIN6	Digital inputs can be isolated from ground, see chapter 6.2.2.2 <i>Isolation of digital inputs from ground.</i>
18	Analogue signal (+output)	Analogue output channel 1, selection 0 -20 mA, load <500 Ω Default: 0-20 mA 0-10 V Resolution 0.1 %, accuracy ± 2 % Selection V/mA with dip-switches (see chapter 6.2.2.1 <i>Selection of terminal functions with DIP switches</i>) Short-circuit protected
19	Analogue output common	
30	24V auxiliary input voltage	Can be used as external power backup for the control unit
A	RS485	Differential receiver/transmitter Set bus termination with dip switches (see chapter 6.2.2.1 <i>Selection of terminal functions with DIP switches</i>). Termination resistance = 220 Ω
B	RS485	

Table 55: The standard relay board (+SBF3)

Terminal	Signal	Technical information
21	Relay output 1 *	Change-over contact (SPDT) relay. 5.5 mm isolation between channels. Switching capacity <ul style="list-style-type: none"> • 24 VDC/8 A • 250 VAC/8 A • 125 VDC/0.4 A Minimum switching load <ul style="list-style-type: none"> • 5 V/10 mA
22		
23		
24	Relay output 2 *	Change-over contact (SPDT) relay. 5.5 mm isolation between channels. Switching capacity <ul style="list-style-type: none"> • 24 VDC/8 A • 250 VAC/8 A • 125 VDC/0.4 A Minimum switching load <ul style="list-style-type: none"> • 5 V/10 mA
25		
26		
32	Relay output 3 *	Normally-open (NO or SPST) contact relay. 5.5 mm isolation between channels. Switching capacity <ul style="list-style-type: none"> • 24 VDC/8 A • 250 VAC/8 A • 125 VDC/0.4 A Minimum switching load <ul style="list-style-type: none"> • 5 V/10 mA
33		

* = If you use 230 VAC as control voltage from the output relays, the control circuitry must be powered with a separate isolation transformer to limit the short circuit current and the overvoltage spikes. This is to prevent welding on the relay contacts. Refer to standard EN 60204-1, section 7.2.9.

Table 56: The optional relay board (+SBF4)

Terminal	Signal	Technical information
21	Relay output 1 *	Change-over contact (SPDT) relay. 5.5 mm isolation between channels. Switching capacity <ul style="list-style-type: none"> • 24 VDC/8 A • 250 VAC/8 A • 125 VDC/0.4 A Minimum switching load <ul style="list-style-type: none"> • 5 V/10 mA
22		
23		
24	Relay output 2 *	Change-over contact (SPDT) relay. 5.5 mm isolation between channels. Switching capacity <ul style="list-style-type: none"> • 24 VDC/8 A • 250 VAC/8 A • 125 VDC/0.4 A Minimum switching load <ul style="list-style-type: none"> • 5 V/10 mA
25		
26		
28	TI1+ TI1-	Thermistor input Rtrip = 4.7 kΩ (PTC) Measuring voltage 3.5V
29		

* = If you use 230 VAC as control voltage from the output relays, the control circuitry must be powered with a separate isolation transformer to limit the short circuit current and the overvoltage spikes. This is to prevent welding on the relay contacts. Refer to standard EN 60204-1, section 7.2.9.

VACON®

www.danfoss.com

Vacon Ltd
Member of the Danfoss Group
Runsorintie 7
65380 Vaasa
Finland

Document ID:



Rev. F

Sales code: DOC-INS100WM+DLUK