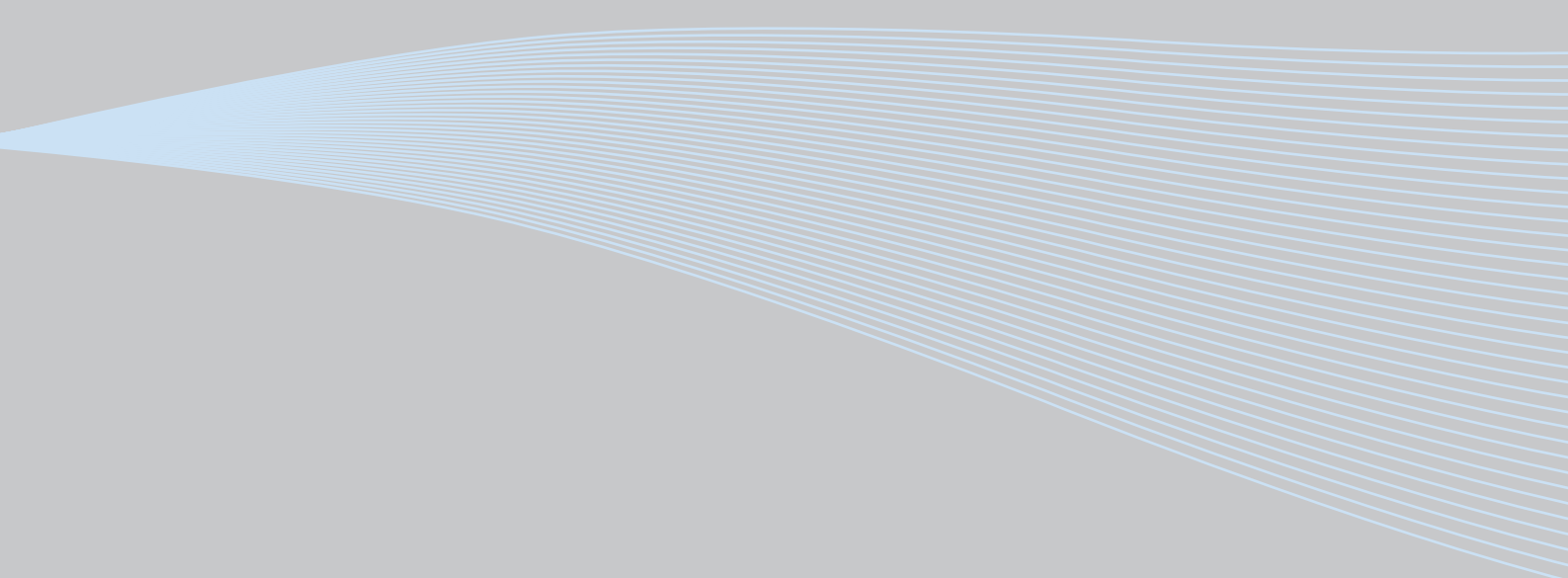


VACON[®] 20 X
AC DRIVES

BH APPLICATION MANUAL



INDEX

Document ID: DPD01381A

Rev. A

Version release date: 11.10.13

Corresponds to application package ACIT1124V101.vcx

1.	BH Application	2
1.1	Specific functions of Vacon BH application	2
1.2	ASi Board Diagnostic	3
1.3	Description of the terminals (D-option with AS-interface)	4
1.3.1	MU2 connections	4
1.3.2	MU3 connections	6
1.4	Description of the terminals (D-option with Profibus)	8
1.4.1	MU2 connections	8
1.4.2	MU3 connections	10
2.	Description of Groups	12
2.1	Monitor group: menu MON	12
2.1.1	ASi	12
2.1.2	Sensors	12
2.1.3	Motor	12
2.1.4	Drive	13
2.2	Parameter Groups: Menu PAR	14
2.2.1	Group Motor settings: Menu PAR G1	15
2.2.2	Group Start/Stop Settings: Menu PAR G2	16
2.2.3	Group References: Menu PAR G3	17
2.2.4	Group Ramps: Menu PAR G4	19
2.2.5	Group Input functions: Menu PAR G5	20
2.2.6	Group Output functions: Menu PAR G6	21
2.2.7	Group Mechanical brake: Menu PAR G7	22
2.2.8	Group Supervisions: Menu PAR G8	23
2.2.9	Group Motor Control: Menu PAR G9	24
2.2.10	Group Protections: Menu PAR G10	25
2.2.11	Group Automatic reset: Menu PAR G11	27
2.2.12	Group Non-ASi fieldbus: Menu PAR G12	28
2.2.13	Group Analogue output: Menu Par G13	29
2.2.14	Group User interface: Menu Par G14	29
2.3	System parameters, Faults and History faults: Menu FLT	30
2.4	Keypad Reference: Menu REF	32
3.	Parameter description	34
3.1	Motor Settings	34
3.2	Start/Stop settings	36
3.3	References	38
3.4	Ramps	40
3.5	Input functions	42
3.6	Output functions	44
3.7	Mechanical brake	46
3.8	Supervisions	47
3.9	Motor control	48
3.10	Protections	52
3.11	Automatic reset	58
3.12	Non-ASi fieldbus	59
3.12.1	Modbus fieldbus mapping	60
3.13	Analogue Output	62
3.14	User interface	62

4. Fault tracing 64

1. BH APPLICATION

The VACON® 20 CP/X drive with +D option contains a preloaded application for instant use. The parameters of this application are listed in chapter 2.2 of this manual and explained in more detail in chapter 2.

1.1 SPECIFIC FUNCTIONS OF VACON BH APPLICATION

The Vacon BH application allows flexible use of VACON® 20 CP/X frequency converters. The visibility of parameters and monitors is arranged in three access levels, selected by parameter P14.1.

Code	Parameter	Min	Max	Default	Description
P14.1	Parameter access level	0	2	0	0 = Basic 1 = Advanced 2 = Service

Basic:

- Monitor of ASi inputs and outputs (only with +D option and AS-interface connection)
- Monitor of sensors
- Monitor of main motor variables
- Setting of motor data
- Setting of Run control mode and commonly used speed reference
- Setting of basic ramp times
- Setting of quick stop function
- Setting of ASi inputs and outputs functions

Advanced:

- Basic + Monitor of more drive/motor variables
- More options for Start/stop and reference selection
- Setting of a second set of ramp times
- Setting of advanced motor control
- Setting of mechanical brake control
- Setting of protections and autoreset

Service:

- Advanced + Monitor of drive internal I/Os
- Setting of some extra motor control and protections features
- Setting of analogue and relay outputs¹⁾

¹⁾terminals of analogue output and relays are not accessible in standard Vacon 20 CP/X+D drive.

1.2 ASI BOARD DIAGNOSTIC

This information is valid only for Vacon® 20X with +D option and AS-interface connection.

Monitor V1.3 shows the state of ASi board, as numeric code.

Visual information is provided by red Fault led on the drive's cover.

Off: no anomaly

On: cumulative fault state. Reset is needed to restore operations.

Slow blinking: ASi board is not powered.

Fast blinking: ASi board is powered, but not communicating (to see V1.3).

A fault condition (code 64) is generated if communication fails while the drive is in Run state in Automatic mode.

This fault is automatically reset when Manual mode is selected. The drive can operate in Manual mode, even though the ASi anomaly is still displayed (alarm code 64).

Run is prevented in Automatic mode, until communications is restored.

1.3 DESCRIPTION OF THE TERMINALS (D-OPTION WITH AS-INTERFACE)

The following pictures describe the power and M12 terminals in Vacon 20X drives with D-option and AS-interface connection.

1.3.1 MU2 CONNECTIONS

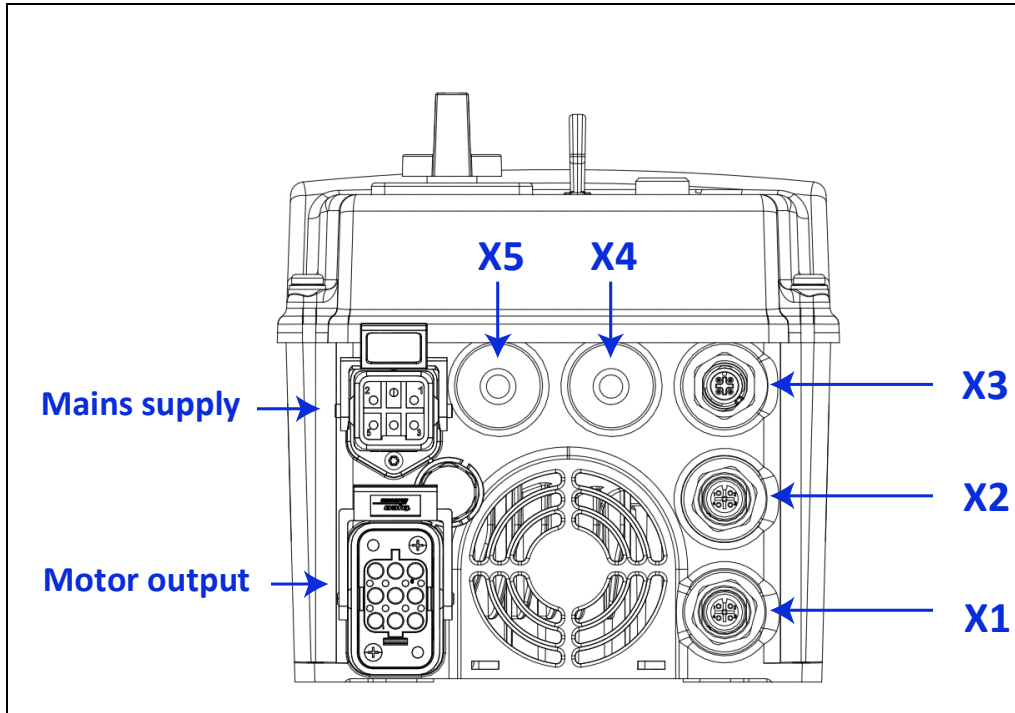


Figure 1. Power and control terminals in MU2.

Mains supply / Type HAN Q5/0 (Male)	
Pin	Function
1	L1
2	L2
3	L3
4	-
5	-
PE	Protective Earth

Table 1. Mains supply connector, MU2.

Motor output / Type HAN Q8 (Female)	
Pin	Function
1	U
2	Not connected
3	W
4	Brake (-)
5	Temperature sensor (+)
6	Brake (+)
7	V
8	Temperature sensor (-)
PE	Protective Earth

Table 2. Motor supply connector, MU2

	X1 Digital Input / Type M12 A-Coding - 5 pole (Female)	
	Pin	Function
	1	+24V [25mA max.]
	2	D input 1
	3	GND
	4	D input 2
5	Functional Earth	

Table 3. X1 connector, MU2.

	X2 Digital Input / Type M12 A-Coding - 5 pole (Female)	
	Pin	Function
	1	+24V [25mA max.]
	2	D input 3
	3	GND
	4	D input 4
5	Functional Earth	

Table 4. X2 connector, MU2.

	X3 ASi connections / Type M12 A-Coding - 4 pole (Male)	
	Pin	Function
	1	ASi +
	2	0V
	3	ASi -
4	+24V	

Table 5. AS-interface connector, MU2.

1.3.2 MU3 CONNECTIONS

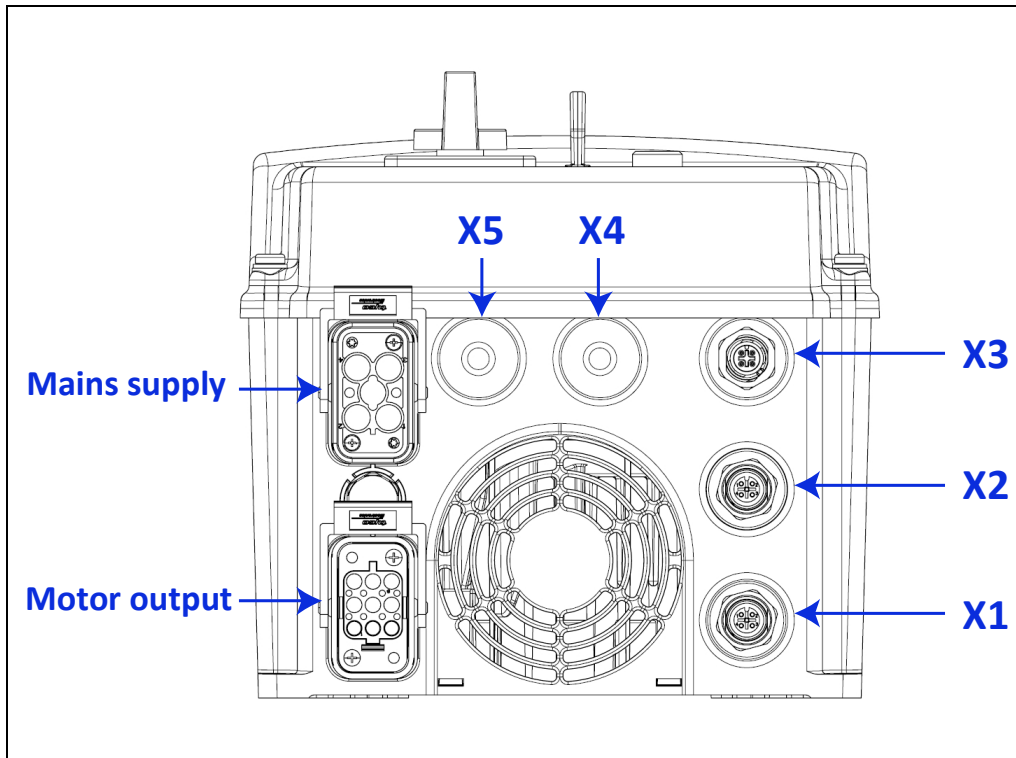


Figure 2. Power and control terminals in MU3.

Mains supply / Type HAN Q4/2 (Male)	
Pin	Function
1	L1
2	L2
3	L3
4	-
11	-
12	-
PE	Protective Earth

Table 6. Mains supply connector, MU3.

Motor output / Type HAN Q8 (Female)	
Pin	Function
1	U
2	Not connected
3	W
4	Brake (-)
5	Temperature sensor (+)
6	Brake (+)
7	V
8	Temperature sensor (-)
PE	Protective Earth

Table 7. Motor supply connector, MU3.

	X1 Digital Input / Type M12 A-Coding - 5 pole (Female)	
	Pin	Function
	1	+24V (25mA max.)
	2	D input 1
	3	GND
	4	D input 2
	5	Functional Earth

Table 8. X1 connector, MU3.

	X2 Digital Input / Type M12 A-Coding - 5 pole (Female)	
	Pin	Function
	1	+24V (25mA max.)
	2	D input 3
	3	GND
	4	D input 4
	5	Functional Earth

Table 9. X2 connector, MU3.

	X3 ASi connections / Type M12 A-Coding - 4 pole (Male)	
	Pin	Function
	1	ASi +
	2	0V
	3	ASi -
	4	+24V

Table 10. AS-interface connector, MU3.

1.4 DESCRIPTION OF THE TERMINALS (D-OPTION WITH PROFIBUS)

The following pictures describe the power and M12 terminals in Vacon 20X drives with D-option and Profibus connection.

1.4.1 MU2 CONNECTIONS

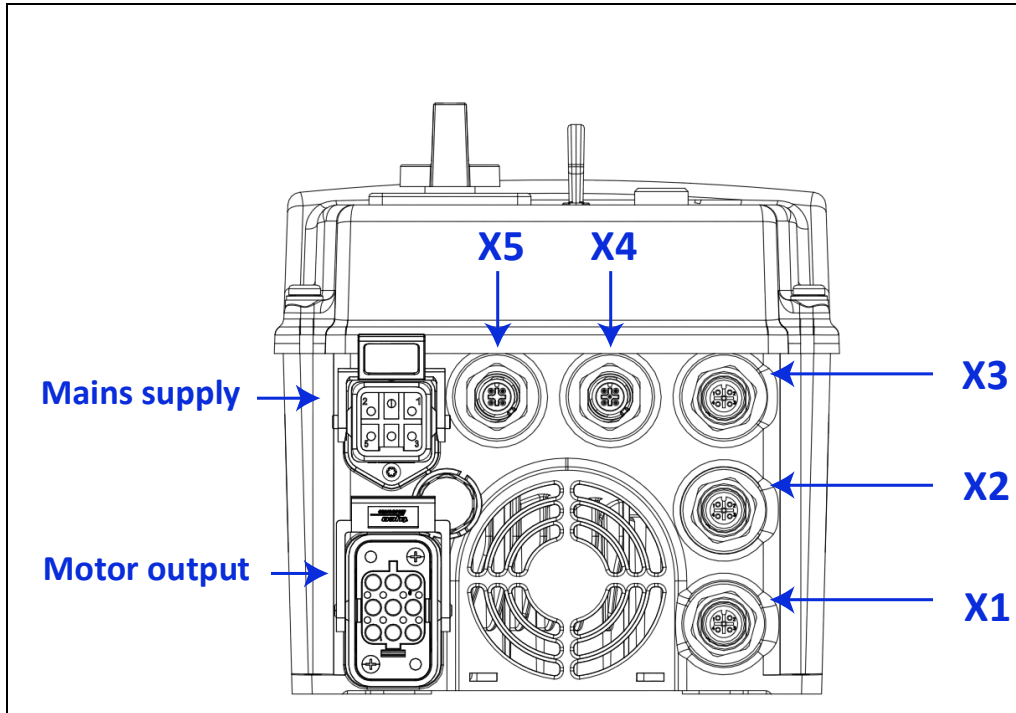


Figure 3. Power and control terminals in MU2.

Mains supply / Type HAN Q5/0 (Male)	
Pin	Function
1	L1
2	L2
3	L3
4	-
5	-
PE	Protective Earth

Table 11. Mains supply connector, MU2.

Motor output / Type HAN Q8 (Female)	
Pin	Function
1	U
2	Not connected
3	W
4	Brake (-)
5	Temperature sensor (+)
6	Brake (+)
7	V
8	Temperature sensor (-)
PE	Protective Earth

Table 12. Motor supply connector, MU2

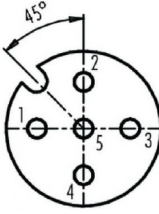
	X1 Digital Input / Type M12 A-Coding – 5 pole (Female)	
	Pin	Function
	1	+24V (25mA max.)
	2	D input 1
	3	GND
	4	D input 2
	5	Functional Earth

Table 13. X1 connector, MU2.

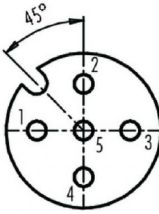
	X2 Digital Input / Type M12 A-Coding – 5 pole (Female)	
	Pin	Function
	1	+24V (25mA max.)
	2	D input 3
	3	GND
	4	D input 4
	5	Functional Earth

Table 14. X2 connector, MU2.

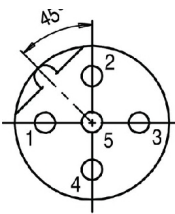
	X3 Profibus / Type M12 B-Coding – 5 pole (Female)	
	Pin	Function
	1	-
	2	A (green)
	3	-
	4	B (red)
	5	-

Table 15. Profibus Female connector, MU2.

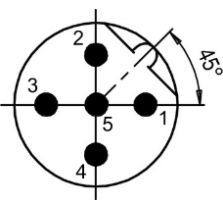
	X4 Profibus / Type M12 B-Coding – 5 pole (Male)	
	Pin	Function
	1	-
	2	A (green)
	3	-
	4	B (red)
	5	-

Table 16. Profibus Male connector, MU2.

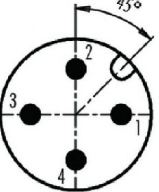
	X5 Auxiliary power supply / Type M12 A-Coding – 4 pole (Male)	
	Pin	Function
	1	Power supply +24V
	2	-
	3	Power supply GND
	4	-

Table 17. Auxiliary power supply connector, MU2.

1.4.2 MU3 CONNECTIONS

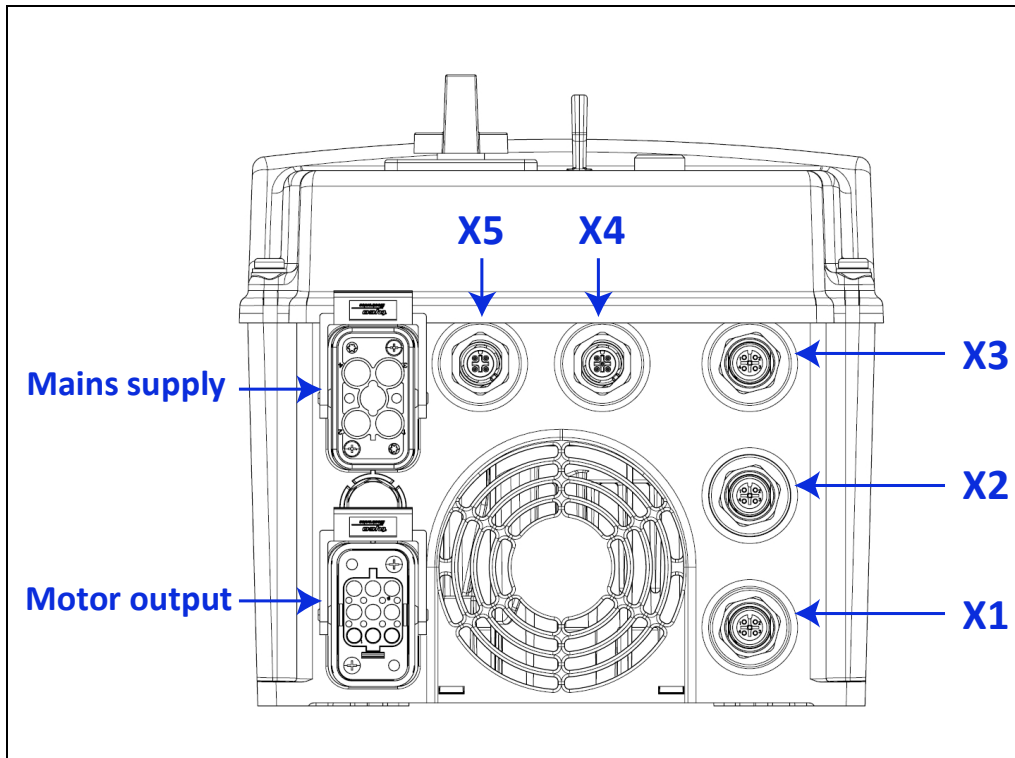


Figure 4. Power and control terminals in MU3.

Mains supply / Type HAN Q4/2 (Male)	
Pin	Function
1	L1
2	L2
3	L3
4	-
11	-
12	-
PE	Protective Earth

Table 18. Mains supply connector, MU3.

Motor output / Type HAN Q8 (Female)	
Pin	Function
1	U
2	Not connected
3	W
4	Brake (-)
5	Temperature sensor (+)
6	Brake (+)
7	V
8	Temperature sensor (-)
PE	Protective Earth

Table 19. Motor supply connector, MU3.

X1 Digital Input / Type M12 A-Coding – 5 pole (Female)	
Pin	Function
1	+24V (25mA max.)
2	D input 1
3	GND
4	D input 2
5	Functional Earth

Table 20. X1 connector, MU3.

X2 Digital Input / Type M12 A-Coding – 5 pole (Female)	
Pin	Function
1	+24V (25mA max.)
2	D input 3
3	GND
4	D input 4
5	Functional Earth

Table 21. X2 connector, MU3.

X3 Profibus / Type M12 B-Coding – 5 pole (Female)	
Pin	Function
1	-
2	A (green)
3	-
4	B (red)
5	-

Table 22. Profibus Female connector, MU3.

X4 Profibus / Type M12 B-Coding – 5 pole (Male)	
Pin	Function
1	-
2	A (green)
3	-
4	B (red)
5	-

Table 23. Profibus Male connector, MU3.

X5 Auxiliary power supply / Type M12 A-Coding – 4 pole (Male)	
Pin	Function
1	Power supply +24V
2	-
3	Power supply GND
4	-

Table 24. Auxiliary power supply connector, MU3.

2. DESCRIPTION OF GROUPS

2.1 MONITOR GROUP: MENU MON

VACON® 20 CP/X AC drive provides you with a possibility to monitor the actual values of parameters and signals as well as statuses and measurements. Some of the values to be monitored are adjusted. See Table 25, Table 26, Table 27 and Table 28 in which the monitoring values are presented.

2.1.1 ASi

Code	Monitoring value	Unit	Level	Description
V1.1	ASi Outputs 4, 3, 2, 1		Basic	State of received bits on ASi board
V1.2	ASi Inputs 4, 3, 2, 1		Basic	State of transmitted bits on ASi board
V1.3	ASi board state		Basic	0: power off 1: communication ok 2: no master 3: address=0 4: periphery fault 5: serious periphery fault

Table 25: ASi monitoring items.

NOTE: these values are valid only with Vacon 20 CP/X +D and AS-interface connection.

2.1.2 SENSORS

Code	Monitoring value	Unit	Level	Description
V2.1	Sensors 4, 3, 2, 1		Basic	State of sensors read on digital inputs

Table 26: Sensors monitoring item.

2.1.3 MOTOR

Code	Monitoring value	Unit	Level	Description
V3.1	Output frequency	Hz	Basic	Output frequency to motor
V3.2	Frequency reference	Hz	Basic	Frequency reference to motor control
V3.3	Motor speed	rpm	Basic	Motor speed in rpm
V3.4	Motor current	A	Basic	
V3.5	Motor torque	%	Advanced	Calculated shaft torque
V3.6	Motor shaft power	%	Advanced	Total power consumption of AC drive
V3.7	Motor voltage	V	Advanced	
V3.8	Motor temperature	%	Advanced	Calculated motor temperature
V3.9	Process variable		Advanced	Scaled process variable

Table 27: Motor monitoring items.

2.1.4 DRIVE

Code	Monitoring value	Unit	Level	Description
V4.1	DC link voltage	V	Advanced	
V4.2	Unit temperature	°C	Advanced	Heatsink temperature
V4.3	Board temperature	°C	Service	Power board temperature
V4.4	Actual output frequency	Hz	Service	Output frequency inclusive slip compensation
V4.5	Droop frequency reference	Hz	Service	Frequency setpoint inclusive droop correction
V4.6	Analogue input 1	%	Service	Analogue input AI1
V4.7	Analogue input 2	%	Service	Analogue input AI2
V4.8	DI3, DI2, DI1		Service	Digital inputs status
V4.9	DI6, DI5, DI4		Service	Digital inputs status
V4.10	DO, RO2, RO1		Service	Digital outputs status
V4.11	Analogue output	%	Service	Analogue output

Table 28: Drive monitoring items.


2.2 PARAMETER GROUPS: MENU PAR

The Decentralized Application embodies the following parameter groups:

Menu and Parameter group	Description
Group Motor settings: Menu PAR G1	Motor settings
Group Start/Stop Settings: Menu PAR G2	Start/Stop and mode settings
Group References: Menu PAR G3	Frequency reference selection
Group Ramps: Menu PAR G4	Ramp times
Group Input functions: Menu PAR G5	Digital input programming
Group Output functions: Menu PAR G6	ASi and digital output programming
Group Mechanical brake: Menu PAR G7	Mechanical brake programming
Group Supervisions: Menu PAR G8	Supervision programming
Group Motor Control: Menu PAR G9	Motor control and U/f parameters
Group Protections: Menu PAR G10	Protections configuration
Group Automatic reset: Menu PAR G11	Auto reset after fault configuration
Group Non-ASi fieldbus: Menu PAR G12	Non-ASi Fieldbus data out parameters
Group Analogue output: Menu Par G13	Analogue output programming
Group User interface: Menu Par G14	User interface parameters

Table 29: Parameter groups

Column explanations:

- Code = Location indication on the keypad; Shows the operator the parameter number.
- Parameter= Name of parameter
- Min = Minimum value of parameter
- Max = Maximum value of parameter
- Unit = Unit of parameter value; Given if available
- Default = Value preset by factory
- ID = ID number of the parameter
- Description= Short description of parameter values or its function
-  = The parameter may be changed only in Stop state

2.2.1 GROUP MOTOR SETTINGS: MENU PAR G1

Code	Parameter	Min	Max	Unit	Default	Level	Description
P1.1	Motor nominal voltage	120	500	V	400	Basic	Find this value U_n on the rating plate of the motor. This parameter sets the voltage at the field weakening point to $100\% * U_{nMotor}$. Note also used connection (Delta/Star).
P1.2	Motor nominal frequency	8.00	320.00	Hz	50.00	Basic	Find this value f_n on the rating plate of the motor.
P1.3	Motor nominal speed	80	20000	rpm	1440	Basic	Find this value n_n on the rating plate of the motor.
P1.4	Motor nominal current	$0.2 * I_H$	$2 * I_H$	A	I_H	Basic	Find this value I_n on the rating plate of the motor.
P1.5	Motor Cos Phi	0.30	1.00		0.85	Basic	Find this value on the rating plate of the motor
P1.6	Motor current limit	$0.2 * I_H$	$2 * I_H$	A	$1.5 * I_H$	Basic	Maximum motor current from AC drive
P1.7	U/f optimization	0	1		1	Basic	0 = Not active 1 = Auto torque boost
P1.8	Motor control mode	0	1		0	Advanced	0 = Frequency control 1 = Speed control
P1.9	Load drooping	0.00	20.00	%	0.00	Advanced	Speed loss at 100% load
P1.10	Motor Identification	0	1		0	Basic	0 = not active 1 = standstill identification (to activate, RUN command within 20s)

Table 30: Group Motor settings.

NOTE!	P1.6 is automatically set equal to 150% of motor nominal current when P1.4 is modified
--------------	--

2.2.2 GROUP START/STOP SETTINGS: MENU PAR G2

Code	Parameter	Min	Max	Unit	Default	Level	Description
P2.1	AUTO Start/Stop logic	0	3		0	Basic	Logic = 0: Start sgn 1 = Start Forward Start sgn 2 = Start Backward Logic = 1: Start sgn 1 = Start Forward (edge) Start sgn 2 = Start Backward (edge) Logic = 2: Start sgn 1 = Start Start sgn 2 = Reverse Logic = 3: Start sgn 1 = Start (edge) Start sgn 2 = Reverse
P2.2	AUTO Run control	0	1*		1	Advanced	0= Start 1-Start 2 signals 1= non-ASi fieldbus
P2.3	Start function	0	1		0	Advanced	0=Ramping 1=Flying start
P2.4	Stop function	0	1		0	Advanced	0=Coasting 1=Ramping
P2.5	Quick Stop Function	0	1		0	Basic	0=Signal level 1=Signal edge
P2.6	Manual Start mode	0	1		1	Advanced	0=Signal level 1=Signal edge

Table 31: Group Start/Stop settings.

NOTE!	(*)Selection 1 is available only if ASi board is not installed. In this case a different fieldbus can be used to control the drive. When ASi board is installed this parameter is automatically set to 0.
--------------	---

2.2.3 GROUP REFERENCES: MENU PAR G3

Code	Parameter	Min	Max	Unit	Default	Level	Description
P3.1	Minimum frequency	0.00	P3.2	Hz	0.00	Basic	Minimum allowed frequency reference
P3.2	Maximum frequency	P3.1	320.00	Hz	50.00	Basic	Maximum allowed frequency reference
P3.3	AUTO Frequency reference selection	0	2 ¹⁾		2	Basic	Selection of AUTO reference source: 0 = Preset frequency 0 1 = Motor potentiometer 2 = Non-ASi fieldbus
P3.4	Preset frequency 0	P3.1	P3.2	Hz	50.00	Basic	Multistep speed 0
P3.5	Preset frequency 1	P3.1	P3.2	Hz	10.00	Basic	Multistep speed 1 ²⁾
P3.6	Preset frequency 2	P3.1	P3.2	Hz	15.00	Basic	Multistep speed 2 ²⁾
P3.7	Preset frequency 3	P3.1	P3.2	Hz	20.00	Basic	Multistep speed 3 ²⁾
P3.8	Preset frequency 4	P3.1	P3.2	Hz	25.00	Advanced	Multistep speed 4 ²⁾
P3.9	Preset frequency 5	P3.1	P3.2	Hz	30.00	Advanced	Multistep speed 5 ²⁾
P3.10	Preset frequency 6	P3.1	P3.2	Hz	40.00	Advanced	Multistep speed 6 ²⁾
P3.11	Preset frequency 7	P3.1	P3.2	Hz	50.00	Advanced	Multistep speed 7 ²⁾
P3.12	Motor potentiometer Mode	0	1		0	Advanced	0: Step up/down 1: Continuous
P3.13	Motor potentiometer Step Up	0.01	50.00	Hz	5.00	Basic	At any edge of increase signal
P3.14	Motor potentiometer Step Down	0.01	50.00	Hz	5.00	Basic	At any edge of decrease signal
P3.15	Motor potentiometer in Reverse	0	1		0	Basic	0: Forward 1: Reverse
P3.16	Motor potentiometer Ramp time	1	50	Hz/s	5	Advanced	Rate of change in the motor potentiometer reference when increased or decreased.
P3.17	Motor potentiometer Copy ref.	0	1		0	Advanced	In case MotPot is alternated with Preset. 0: Keep memory of previous MotPot Ref 1: Start from actual Ref
P3.18	Motor potentiometer Reset	0	2		0	Basic	Motor potentiometer frequency reference reset logic. 0 = No reset 1 = Reset if stopped or powered down 2 = Reset if powered down
P3.19	MANUAL Reference selection	0	2		1 ³⁾	Advanced	Selection of MANUAL reference source: 0 = Manual Preset speed 1 = Panel potentiometer 2 = Manual Preset speed + Panel Potentiometer Correction
P3.20	Manual Preset speed	0.00	P3.2	Hz	50.00	Basic	

Table 32: Group References.

P3.21	Panel Potentiometer Min. Frequency	0.00	P3.21	Hz	0.0	Advanced	Minimum freq. reference from potentiometer
P3.22	Panel Potentiometer Max. Frequency	P3.20	P3.2	Hz	50.00	Advanced	Maximum freq.reference from potentiometer
P3.23	Panel Potentiometer Min. Correction	-100.00	0.00	%	-10.00	Advanced	Ref adjust at minimum potentiometer signal
P3.24	Panel Potentiometer Max. Correction	0.00	100.00	%	10.00	Advanced	Ref adjust at maximum potentiometer signal

Table 32: Group References.

NOTE!	<p>¹⁾ Selection 2 is available only if ASi board is not installed. In this case a different fieldbus can be used to control the reference. When ASi board is installed this parameter is automatically set to 0.</p> <p>²⁾ In AUTO mode, preset speed 1-8 can be directly activated by ASi outputs or Sensors signals, independently from P3.3 setting. If P3.3 = 1 and the reference is restored to motor potentiometer, after a preset speed, P3.17 defines the initial value for the reference.</p> <p>³⁾ When ASi board is installed this parameter is automatically set to 0.</p>
--------------	---

2.2.4 GROUP RAMPS: MENU PAR G4

Code	Parameter	Min	Max	Unit	Default	Level	Description
P4.1	Acceleration time 1	0.1	3000.0	s	3.0	Basic	Defines the time required for the output frequency to increase from zero frequency to maximum frequency
P4.2	Deceleration time 1	0.1	3000.0	s	3.0	Basic	Defines the time required for the output frequency to decrease from maximum frequency to zero frequency
P4.3	Ramp 1 shape	0.0	10.0	s	0.0	Basic	Rounded speed profile.
P4.4	Acceleration time 2	0.1	3000.0	s	10.0	Advanced	Time from 0 to max frequency
P4.5	Deceleration time 2	0.1	3000.0	s	10.0	Advanced	Time from 0 to max frequency
P4.6	Ramp 2 shape	0.0	10.0	s	0.0	Advanced	Rounded speed profile.
P4.7	Acceleration time 2 freq. threshold	0.00	P3.2	Hz	0.00	Advanced	Threshold for auto change from acc1 to acc2
P4.8	Deceleration time 2 freq. threshold	0.00	P3.2	Hz	0.00	Advanced	Threshold for auto change from dec2 to dec1
P4.9	Quick Stop dec. time	0.1	3000.0	s	1.0	Basic	Time from max frequency to 0

Table 33: Group Ramps.

2.2.5 GROUP INPUT FUNCTIONS: MENU PAR G5

Code	Parameter	Min	Max	Unit	Default	Level	Description
P5.1	Start signal 1	0	8		1	Basic	Start signal 1 when control place is I/O 1 (FWD) See P2.1 for function. 0 = not used 1 = ASi Output 1 2 = ASi Output 1 3 = ASi Output 1 4 = ASi Output 1 5 = Sensor 1 6 = Sensor 2 7 = Sensor 3 8 = Sensor 4
P5.2	Start signal 2	0	8		2	Basic	Start signal 2 when control place is I/O 1 (REV). See P2.1 for function. See P5.1 for selections.
P5.3	Preset frequency selection 0	0	8		3	Basic	Binary selector for Preset speeds (0-7).
P5.4	Preset frequency selection 1	0	8		0	Basic	Binary selector for Preset speeds (0-7).
P5.5	Preset frequency selection 2	0	8		0	Advanced	Binary selector for Preset speeds (0-7).
P5.6	Fault reset	0			4	Basic	Resets all active faults
P5.7	Force brake	0	8		0	Basic	Forces brake open
P5.8	External fault open	0	8		0	Advanced	Fault is signal low See P5.1 for selections
P5.9	External fault close	0	8		0	Advanced	Fault if signal high See P5.1 for selections
P5.10	Run enable	0	8		0	Advanced	Must be on to set drive in Ready state
P5.11	Acc/dec ramp selection	0	8		0	Advanced	Activates ramp 2 See P5.1 for selections
P5.12	Motor potentiometer UP	0	8		0	Basic	Reference increase See P5.1 for selections
P5.13	Motor potentiometer DOWN	0	8		0	Basic	Reference decrease See P5.1 for selections
P5.14	Quick Stop open	0	8		0	Basic	If configured, low signal activates stop with specific ramp. See P5.1 for selections.
P5.15	Quick Stop open	0	8		0	Basic	If configured, high signal activates stop with specific ramp. See P5.1 for selections.

Table 34: Group Input functions.

2.2.6 GROUP OUTPUT FUNCTIONS: MENU PAR G6

Code	Parameter	Min	Max	Unit	Default	Level	Description
P6.1	ASi Input 1	0	17		5	Basic	Bit0 transmitted on ASi bus 0: not used 1: Sensor 1 2: Sensor 2 3: Sensor 3 4: Sensor 4 5: Ready + Auto 6: Run 7: Fault 8: Fault or warning 9: Reverse 10: Running feedback ¹⁾ 11: Automatic mode 12: At speed (internal) 13: Output freq superv 14: Output current superv 15: Brake command 16: Quick stop 17: Ready
P6.2	ASi Input 2	0	17		13	Basic	Bit1 transmitted on ASi bus. See P6.1 for selections
P6.3	ASi Input 3	0	17		2	Basic	Bit2 transmitted on ASi bus. See P6.1 for selections
P6.4	ASi Input 4	0	17		4	Basic	Bit2 transmitted on ASi bus. See P6.1 for selections
P6.5	R01 function ²⁾	0	13		0	Service	Function selection for R01: 0 = Not used 1 = Ready 2 = Run 3 = General fault 4 = General fault inverted 5 = Warning 6 = Reversed 7 = At speed 8 = Output freq. supervision 9 = Output current superv. 10 = ASi Output 1 11 = ASi Output 2 12 = ASi Output 3 13 = ASi Output 4
P6.6	R02 function ²⁾	0	13		0	Service	See P6.5
P6.7	R01 ON delay	0.00	320.00	s	0.00	Service	ON delay for relay
P6.8	R01 OFF delay	0.00	320.00	s	0.00	Service	OFF delay for relay
P6.9	R01 inversion	0	1		0	Service	0 = no inversion 1 = inverted
P6.10	R02 ON delay	0.00	320.00	s	0.00	Service	See P6.7
P6.11	R02 OFF delay	0.00	320.00	s	0.00	Service	See P6.8

Table 35: Group Output Functions.

NOTE!	¹⁾ when Automatic mode is not assigned to any Input, Running Feedback includes also information about Automatic.			
	Automatic	Run	Out Freq >= Setpoint	Feedback
	0	-	-	0
	1	0	-	1
	1	1	0	0
	1	1	1	1
	²⁾ relay terminals are not accessible in standard V20X+D drive			

2.2.7 GROUP MECHANICAL BRAKE: MENU PAR G7

Code	Parameter	Min	Max	Unit	Default	Level	Description
P7.1	Brake open frequency ¹⁾	0.00	10.00	Hz	0.00	Advanced	Frequency threshold for brake open
P7.2	Brake open current	0.00	100.0	%	0.0	Advanced	Current threshold for brake open
P7.3	Brake close frequency	0.00	10.00	Hz	1.00	Advanced	Frequency threshold for brake close (Start = 0)
P6.4	Brake close delay	0.00	10.00	s	0.00	Advanced	Respected in any condition (fault, no enable), apart direct control from Asi input.

Table 36: Group Mechanical brake.

NOTE!	¹⁾ note: if P7.1 > 0Hz, frequency reference is internally limited to P7.1 + 0.1 Hz until the brake is released. If the thresholds in P7.1 and P7.2 are not reached within 3s from Start command Fault 56 "Brake Time Out" is triggered.
--------------	--

2.2.8 GROUP SUPERVISIONS: MENU PAR G8

Code	Parameter	Min	Max	Unit	Default	Level	Description
P8.1	Running Ok speed tolerance	0.0	100.0	%	90.0	Advanced	
P8.2	Output frequency supervision	0	2		2	Advanced	0 = not used 1 = Low limit 2 = High limit
P8.3	Frequency supervision limit	0.00	P3.2	Hz	35.00	Advanced	Output frequency supervision threshold
P8.4	Current supervision limit	0.00	2 x I _H	A	0.00	Advanced	Current supervision threshold
P8.5	Process display source selection	0	4		1	Advanced	Selection of variable proportional to process: 0 = Output frequency 1 = Motor speed 2 = Motor torque 3 = Motor power 4 = Motor current
P8.6	Process display decimal digits	0	3		1	Advanced	Decimals on display
P8.7	Process display max value	0.0	3276.7		100.0	Advanced	Process display max value (it depends on P7.11: with zero decimal digit the max value is 32767; with 1 decimal digit the max value is 3276.7)

Table 37: Group supervisions.

2.2.9 GROUP MOTOR CONTROL: MENU PAR G9

Code	Parameter	Min	Max	Unit	Default	Level	Description
P9.1	Field Weakening Point frequency	8.00	320.00	Hz	50.00	Advanced	Field weakening point frequency
P9.2	Field Weakening Point voltage	10.00	200.00	%	100.00	Advanced	Voltage at FWP as % of Motor nominal voltage
P9.3	U/f ratio selection(*)	0	2		0	Advanced	0 = linear 1 = quadratic 2 = programmable
P9.4	U/f midpoint frequency(*)	0.00	P9.2	Hz	50.00	Advanced	Midpoint frequency for programmable U/f curve
P9.5	U/f midpoint voltage(*)	0.00	P9.3	%	100.00	Advanced	Midpoint voltage for programmable U/f curve
P9.6	Zero frequency voltage(*)	0.00	40.00	%	0.00	Advanced	Voltage at 0,00 Hz as % of Motor nominal voltage
P9.7	RS voltage drop(*)	0.00	100.00	%	0.00	Advanced	Voltage drop on the motor windings as % of Motor nominal voltage
P9.8	Switching frequency	1.5	16.0	kHz	4.0	Advanced	Increasing the switching frequency reduces the capacity of the drive.
P9.9	Drooping Mode	0	1		1	Advanced	0: constant 1: speed dependent
P9.10	Droop filter time	0.00	3.00	s	0.10	Advanced	Constant time of filter on droop calculation
P9.11	Brake chopper	0	2		0	Advanced	0 = Disabled 1 = Enabled in RUN 2 = Enabled in READY
P9.12	Brake chopper level	600	900	V	650	Advanced	DC-link voltage to start chopper.
P9.13	DC brake current	0.3 x I _H	2 x I _H	A	I _H	Basic	Defines the current injected into the motor during DC-braking. 0 = Disabled
P9.14	DC braking time at stop	0.00	600.00	s	0.00	Basic	Determines if braking is ON or OFF and the braking time of the DC-brake when the motor is stopping.
P9.15	Frequency to stop DC braking at ramp stop	0.10	10.00	Hz	1.50	Basic	The output frequency at which the DC-braking is applied.
P9.16	DC braking time at start	0.00	600.00	s	0.00	Basic	Determines the braking time of the DC-brake when the motor is starting.
P9.17	Overvoltage controller	0	1		0	Service	0 = Enabled 1 = Disabled
P9.18	Undervoltage controller	0	1		0	Service	0 = Enabled 1 = Disabled
P9.19	Switching frequency controller	0	1		0	Service	0 = Enabled 1 = Disabled

Table 38: Group Motor control.

NOTE!

(*) Parameter is automatically set by motor identification.

2.2.10 GROUP PROTECTIONS: MENU PAR G10



Parameters of Motor thermal protection (P10.9 to P10.12 and P10.18-P10.19)

The motor thermal protection is to protect the motor from overheating. The drive is capable of supplying higher than nominal current to the motor. If the load requires this high current there is a risk that the motor will be thermally overloaded. This is the case especially at low frequencies. At low frequencies the cooling effect of the motor is reduced as well as its capacity. If the motor is equipped with an external fan the load reduction at low speeds is small.

The motor thermal protection is based on a calculated model and it uses the output current of the drive to determine the load on the motor.


The motor thermal protection can be adjusted with parameters. The thermal current I_T specifies the load current above which the motor is overloaded. This current limit is a function of the output frequency.

The thermal stage of the motor can be monitored on the control keypad display. See chapter 1.

	If you use long motor cables (max. 100m) together with small drives (≤ 1.5 kW) the motor current measured by the drive can be much higher than the actual motor current due to capacitive currents in the motor cable. Consider this when setting up the motor thermal protection functions.
	The calculated model does not protect the motor if the airflow to the motor is reduced by blocked air intake grill. The model starts from zero if the control board is powered off.

Parameters of Stall protection (P10.2 to P10.4)

The motor stall protection protects the motor from short time overload situations such as one caused by a stalled shaft. The reaction time of the stall protection can be set shorter than that of motor thermal protection. The stall state is defined with two parameters, P10.3 (*Stall time*) and P10.4 (*Stall frequency limit*). If the current is as high as the P1.6 (Current Limit) and the current limiter has reduced the output frequency below the P10.4 for the time P10.3 than the set limit the stall state is true. There is actually no real indication of the shaft rotation. Stall protection is a type of overcurrent protection.

	If you use long motor cables (max. 100m) together with small drives (≤ 1.5 kW) the motor current measured by the drive can be much higher than the actual motor current due to capacitive currents in the motor cable. Consider this when setting up the motor thermal protection functions.
---	--

Parameters of Underload protection (P10.5 to P10.8)

The purpose of the motor underload protection is to ensure that there is load on the motor when the drive is running. If the motor loses its load there might be a problem in the process, e.g. a broken belt or a dry pump.

Motor underload protection can be adjusted by setting the underload curve with parameters P10.6 (Underload protection: Field weakening area load) and P10.7 (*Underload protection: Zero frequency load*), see below. The underload curve is a squared curve set between the zero frequency and the field weakening point. The protection is not active below 5Hz (the underload time counter is stopped).

The torque values for setting the underload curve are set in percentage which refers to the nominal torque of the motor. The motor's name plate data, parameter motor nominal current and the drive's nominal current I_L are used to find the scaling ratio for the internal torque value. If other than nominal motor is used with the drive, the accuracy of the torque calculation decreases.



If you use long motor cables (max. 100m) together with small drives (≤ 1.5 kW) the motor current measured by the drive can be much higher than the actual motor current due to capacitive currents in the motor cable. Consider this when setting up the motor thermal protection functions.

Code	Parameter	Min	Max	Unit	Default	Level	Description
P10.1	Earth fault	0	2		2	Advanced	0 = No action 1 = Warning 2 = Fault
P10.2	Motor stall fault	0	2		1	Advanced	See P10.1
P10.3	Stall time limit	0.0	300.0	s	5.0	Advanced	This is the maximum time allowed for a stall stage.
P10.4	Stall frequency limit	0.10	320.00	Hz	15.00	Advanced	For a stall state to occur, the output frequency must have remained below this limit for a certain time.
P10.5	Underload fault	0	2		0	Advanced	See P10.1
P10.6	Underload protection: Field weakening area load	10.0	150.0	%	50.0	Advanced	This parameter gives the value for the minimum torque allowed when the output frequency is above the field weakening point.
P10.7	Underload fault: Zero frequency load	5.0	150.0	%	10.0	Advanced	This parameter gives value for the minimum torque allowed with zero frequency.
P10.8	Underload fault: Time limit	1.0	300.0	s	20.0	Advanced	This is the maximum time allowed for an underload state to exist.
P10.9	Motor thermal fault	0	2		2	Advanced	See P10.1
P10.10	Motor ambient temperature factor	-20	100	°C	40	Advanced	Ambient temperature in °C
P10.11	Motor thermal zero speed cooling	0.0	150.0	%	40.0	Advanced	Defines the cooling factor at zero speed in relation to the point where the motor is running at nominal speed without external cooling.
P10.12	Motor thermal time constant	1	200	min	45	Advanced	The time constant is the time within which the calculated thermal stage has reached 63% of its final value.
P10.13	Fieldbus communication fault	0	2		1	Advanced	See P10.1
P10.14	Thermistor fault	0	2		0	Service	See P10.1

Table 39: Group Protections.

P10.15	Response to Safe Torque Off	0	3		1	Advanced	0 = No action 1 = Warning 2 = Fault, not stored in history menu 3 = Fault, stored in history menu
P10.16	Input phase fault	0	2		2	Service	See P10.1
P10.17	Input phase fault ripple limit	0	75		0	Service	0 = internal value 1 = max sensitivity -> 75 = min sensitivity
P10.18	Motor temperature initialization	0	2		2	Service	0 = start from minimum 1 = start from constant value 2 = start from last value
P10.19	Motor temperature initial value	0	100	%	33	Service	Initial value(P10.18 = 1) or factor for last previous value(P10.18 = 2)

Table 39: Group Protections.

2.2.11 GROUP AUTOMATIC RESET: MENU PAR G11

Code	Parameter	Min	Max	Unit	Default	Level	Description
P11.1	Automatic reset	0	1		0	Basic	0 = Disabled 1 = Enabled
P11.2	Wait time	0.10	10.0	s	0.50	Advanced	Wait time before the first reset is executed.
P11.3	Trial time	0.00	60.0	s	30.00	Advanced	When the trial time has elapsed, and the fault is still active, the drive will trip to fault.
P11.4	Number of trials	1	10		3	Advanced	NOTE: Total number of trials (irrespective of fault type)
P11.5	Restart function	0	2		0	Advanced	The start mode for Automatic reset is selected with this parameter: 0 = Ramp 1 = Flying start 2 = According to par. P2.3

Table 40: Group Automatic reset.

2.2.12 GROUP NON-ASI FIELDBUS: MENU PAR G12

Code	Parameter	Min	Max	Unit	Default	Level	Description
P12.1	Fieldbus Data OUT 1 selection	0	10		0	Basic / Service ²⁾	Variable mapped on PD1: 0 = Output current 1 = Motor speed 2 = Motor current 3 = Motor voltage 4 = Motor torque 5 = Motor power 6 = DC-link voltage 7 = Active fault code 8 = Analogue AI1 9 = Analogue AI2 10 = Digital inputs state 11 = PID feedback value 12 = PID setpoint 13 = Analogue AI3 14 = Temperature 1 15 = Temperature 2 16 = Temperature 3
P12.2	Fieldbus Data OUT 2 selection	0	10		1	Basic / Service ²⁾	Variable mapped on PD2. See P12.1
P12.3	Fieldbus Data OUT 3 selection	0	10		2	Basic / Service ²⁾	Variable mapped on PD3. See P12.1
P12.4	Fieldbus Data OUT 4 selection	0	10		4	Basic / Service ²⁾	Variable mapped on PD4. See P12.1
P12.5	Fieldbus Data OUT 5 selection	0	10		5	Basic / Service ²⁾	Variable mapped on PD5. See P12.1
P12.6	Fieldbus Data OUT 6 selection	0	10		3	Basic / Service ²⁾	Variable mapped on PD6. See P12.1
P12.7	Fieldbus Data OUT 7 selection	0	10		6	Basic / Service ²⁾	Variable mapped on PD7. See P12.1
P12.8	Fieldbus Data OUT 8 selection	0	10		7	Basic / Service ²⁾	Variable mapped on PD8. See P12.1
P12.9	ASi Outputs emulation ²⁾	0	5		0	Basic / Service ²⁾	PDI used as ASi outputs emulator. 0 = Not used 1 = PDI1 2 = PDI2 3 = PDI3 4 = PDI4 5 = PDI5

Table 41: Group Non-ASi fieldbus.

NOTE!	¹⁾ Parameters of this group are visible at Basic level when ASi board is not installed. They are anyway visible at Service level.
	²⁾ A different fieldbus can also simulate ASi interface. Outputs and Inputs will be mapped on Process Data.

2.2.13 GROUP ANALOGUE OUTPUT: MENU PAR G13

Code	Parameter	Min	Max	Unit	Default	Level	Description
P13.1	A01 function	0	6		2	Service	0 = Not used (fixed 100%) 1 = Freq. reference (0-fmax) 2 = Output freq. (0 -fmax) 3 = Motor speed (0 - Speed max) 4 = Output current (0-I _{nMotor}) 5 = Motor torque (0-T _{nMotor}) 6 = Motor power (0-P _{nMotor})
P13.2	A01 minimum	0	1		0	Service	0 = 0V 1 = 2V
P13.3	A01 Output scale	0,0	1000,0	%	100.0	Service	Scaling factor
P13.4	A01 filter time	0.00	10.00	s	0.10	Service	Filtering time of analogue output signal. 0 = No filtering

Table 42: Group Analogue output.

2.2.14 GROUP USER INTERFACE: MENU PAR G14

Code	Parameter	Min	Max	Unit	Default	ID	Description
P14.1	Parameters access level	0	2		0	Basic	0 = Basic 1 = Advanced 2 = Service
P14.2	Parameters lock	0	1		0	Basic	0 = Edit Enabled 1 = Edit Disabled

Table 43: Group User interface.

2.3 SYSTEM PARAMETERS, FAULTS AND HISTORY FAULTS: MENU FLT

Code	Parameter	Min	Max	Unit	Default	ID	Description
V1.1	API system SW ID					2314	
V1.2	API system SW version					835	
V1.3	Power SW ID					2315	
V1.4	Power SW version					834	
V1.5	Application ID					837	
V1.6	Application revision					838	
V1.7	System load					839	
When no fieldbus board has been installed, the following values are visible:							
V2.1	Communication status					808	Status of Modbus communication. Format: xx.yyy where xx = 0 - 64 (Number of error messages) yyy = 0 - 999 (Number of good messages)
P2.2	Fieldbus protocol	0	1		0	809	0 = Not used 1 = Modbus used
P2.3	Slave address	1	255		1	810	
P2.4	Baud rate	0	8		5	811	0 = 300 1 = 600 2 = 1200 3 = 2400 4 = 4800 5 = 9600 6 = 19200 7 = 38400 8 = 57800
P2.6	Parity type	0	2		0	813	0 = None 1 = Odd 2 = Even
P2.7	Communication time out	0	255	s	0	814	
P2.8	Reset communication status	0	1		0	815	
When OPTE6 (CANopen) option board has been installed, the following values are visible:							
V2.1	CANopen communication status					14004	
P2.2	CANopen operation mode	1	2		1	14003	
P2.3	CANopen Node ID	1	127		1	14001	
P2.4	CANopen baud rate	1	8		6	14002	
When OPTE7 (DeviceNet) option board has been installed, the following values are visible:							
V2.1	DeviceNet communication status					14014	
P2.2	Output assembly type	20	111		21	14012	
P2.3	MAC ID	0	63		63	14010	
P2.4	Baud Rate	1	3		1	14011	

Table 44: System parameters, Faults and History faults.

P2.5	Input assembly type	70	117		71	14013	
When OPTE3/E5(Profibus) option board has been installed, the following values are visible:							
V2.1	Profibus communication status					14022	
P2.2	Fieldbus protocol					14023	
P2.3	Active protocol					14024	
P2.4	Active baud rate					14025	
P2.5	Telegram type					14027	
P2.6	Operate mode	1	3		1	14021	
P2.7	Slave address	2	126		126	14020	
Other information:							
V3.1	MWh counter					827	
V3.2	Power on day counter					828	
V3.3	Power on hour counter					829	
V3.4	RUN day counter					840	
V3.5	RUN hour counter					841	
V3.6	Fault counter					842	
V3.7	Panel parameter set status monitor						Hidden when PC is connected
P4.2	Restore factory defaults	0	1		0	831	1 = Restore factory defaults for all parameters
P4.3	Password	0	9999		000 0	832	
P4.4	Time for keypad backlight	0	99	min	5	833	
P4.5	Save parameters to Keypad	0	1		0		1= Upload all parameters to Keypad Hidden when PC is connected. This function works properly only with drive supplied.
P4.6	Download parameters from Keypad	0	1		0		1= Download all parameters to Keypad Hidden when PC is connected. This function works properly only with drive supplied.
F5.x	Active fault menu	0	9				
F6.x	Fault history menu	0	9				

Table 44: System parameters, Faults and History faults.

2.4 KEYPAD REFERENCE: MENU REF

This menu is not used even if it is automatically entered when pressing the LOC/REM keypad and shows the frequency reference in Local control mode.

The reference is also not active.

3. PARAMETER DESCRIPTION

Due to its user-friendliness and simplicity of use, the most parameters only require a basic description which is given in the parameter tables in chapter 2.2.

In this chapter, you will find additional information on certain most advanced parameters. Should you not find the information you need contact your distributor.

3.1 MOTOR SETTINGS

P1.1 MOTOR NOMINAL VOLTAGE

Value must be read on motor nameplate. Changing of the value will set the voltage at field weakening point (P9.2) to value 100%.

P1.2 MOTOR NOMINAL FREQUENCY

Value must be read on motor nameplate. Changing of the value will set the field weakening point (P9.1) to same value.

P1.3 MOTOR NOMINAL SPEED

Value must be read on motor nameplate. Speed must be referred to nominal frequency and nominal load condition (not synchronous speed).

P1.4 MOTOR NOMINAL CURRENT

Value must be read on motor nameplate.

P1.5 MOTOR COS PHI

Value must be read on motor nameplate.

P1.6 CURRENT LIMIT

Maximum motor current supplied from the drive. This parameter is automatically set equal to 150% of motor nominal current, when P1.4 is modified. If a different limit is wanted, it must be programmed after setting of P1.4.

P1.7 U/F CURVE OPTIMIZATION

0: Not used

1: Automatic voltage boost (improves motor torque).

P1.8 MOTOR CONTROL MODE

0: Frequency control

1: Speed control (sensorless control)

In speed control, the motor slip is compensated.

P1.9 LOAD DROOPING

This function increases the natural slip of asynchronous motors, by decreasing the output frequency proportionally to motor torque. Frequency is instead increased if the motor is braking. This can help the load sharing, when motors driven by different converters are mechanically coupled.

The parameter sets the speed variation (as % of nominal speed) when the motor is at 100% load. Normally droop action is decreased when the motor is running at low speed. Parameter P9.9 allows to set a speed independent droop.

P1.10 **MOTOR IDENTIFICATION**

This procedure measures motor stator resistance and automatically sets U/f characteristic, to obtain good torque also at low speed.

0: not active

1: standstill identification

Run command must be given and hold high within 20s after programming the value 1. The motor does not rotate and the drive will automatically exit run state at the end of the measurements.

Procedure sets the following parameters: P9.3, P9.4, P9.5, P9.6, P9.7.

Also speed control (P1.8 =1) is activated.

Note: optimized U/f settings will cause motor current values comparable to nominal one, also at very low speed. External cooling of the motor is needed if the motor works in this condition for significant time.

3.2 START/STOP SETTINGS

P2.1 START/DIRECTION LOGIC

AUTO Start/Direction logic

These logics are based on Start1 and Start2 signals (defined with P5.1 and P5.2), which allow the control of Run and direction in AUTOMATIC mode.

0	DIN1: run forward on signal level DIN2: run backward on signal level
1	DIN1: run forward on signal rising edge DIN2: run backward on signal rising edge
2	DIN1: run on signal level DIN2: reverse on signal level
3	DIN1: run on signal rising edge DIN2: reverse on signal level

For mode 0 and 1, only one signal can be high, otherwise alarm 55 is shown.

For mode 1 and 3, Run edge is acquired only if the drive is Ready, in Automatic mode and not in Quick stop state. Run condition is then kept until the signal is high.

P2.2 AUTO RUN CONTROL

This parameter is enabled when ASi board is not present. It defines the source for Run control.

0	Start1- Start2 signals
1	Non-ASi fieldbus

P2.3 START FUNCTION

- 0: Ramping
- 1: Flying start

P2.4 STOP FUNCTION

Selection number	Selection name	Description
0	Coasting	The motor is allowed to stop on its own inertia. The control by the drive is discontinued and the drive current drops to zero as soon as the stop command is given.
1	Ramp	After the Stop command, the speed of the motor is decelerated according to the set deceleration parameters to zero speed.

NOTE: this parameter is forced to 1, in case a Quick Stop signal has been configured.

NOTE: fall of Enable signal, when configured, always determines stop by coasting.

P2.5 QUICK STOP MODE

Quick stop is activated through the input signal defined in P5.14 (or P5.15).

Signal low (or high) forces the drive to stop, ramping down with the time defined in P4.9. The ramp to zero is continued also in case the signal returns high (or low).

This parameter defines the mode Quick stop is managed.

0: Signal level

Quick stop is set when the signal is low (signal defined in P5.14) or high (signal defined in P5.15).

It is reset when the drive has reached stop condition and the signal is restored to normal level. How the drive in AUTO mode actually restarts the motor depend on logic set in P2.1.

If P2.1 = 1 or 3, a new rising edge on Start signal is needed.

If P2.1 = 0 or 2, the drive restarts immediately if Start signal is high.

In MANUAL mode it depends on logic set in P2.6.

If P2.6 = 0, the drive restarts immediately if Start command is still activated.

If P2.6 = 1, a new rising edge on Start command is needed.

1: Signal edge

Quick stop is set on falling edge (signal defined in P5.14) or rising edge (signal defined in P5.15) of the signal.

It is reset when the drive has reached stop condition and the Start signal (Start command on operator panel in MANUAL) is low, independently from the level of Quick stop signal.

Quick stop condition can be diagnosed through ASi input. It is also signalled by Alarm 63.

P2.6 MANUAL START MODE

0: Level

Once the drive is started in Manual mode, it will automatically resume Run condition after a fault or a power loss (if ASi voltage is kept up).

It will restart also after a Quick Stop, if P2.5 = 0.

1: Edge

Once the drive is started in Manual mode, a new start is prevented after a fault, a power loss or a Quick Stop. The previous Run command must be canceled by Stop button, to enable a new start.

3.3 REFERENCES

P3.1 MIN FREQUENCY

Minimum frequency reference, for Automatic control. Manual control allows a different minimum.

Note: if motor current limit is reached, actual output frequency might be lower than parameter. If this is not acceptable, stall protection should be activated.

P3.2 MAX FREQUENCY

Maximum frequency reference, for Automatic and Manual control.

P3.3 AUTO REFERENCE SELECTION

Defines the source of main frequency reference in Automatic.

0: Preset speed 0

1: Motorpotentiometer

2: non ASi Fieldbus (only without ASi board)

Preset speed 1-8 can be directly activated by ASi outputs or sensors.

P3.4 PRESET SPEED 0

Basic preset reference

P3.5 PRESET SPEED 1

P3.6 PRESET SPEED 2

P3.7 PRESET SPEED 3

P3.8 PRESET SPEED 4

P3.9 PRESET SPEED 5

P3.10 PRESET SPEED 6

P3.11 PRESET SPEED 7

Preset speeds are selected by digital signals defined in P5.3, P5.4 and P5.5 (binary code).

P3.12 MOTOR POTENTIOMETER MODE

0: step up / down. Frequency reference is changed at any edge of Increase/Decrease signals, of the quantity defined in P3.13 and P3.14.

1: continuous. Frequency reference is continuously changed when Increase/Decrease signals are high, with the rate defined in P3.15.

P3.13 MOTPOT STEP UP

P3.14 MOTPOT STEP DOWN

Variation of reference at any Inc/Dec signals edge, when drive is in Run state.

Reference is anyway limited between P 3.1 and P 3.2 values.

P3.15 MOTPOT IN REVERSE

0: same reference used in forward

1: different reference

P3.16 MOTPOT RAMP

Rate of reference variation when Inc/Dec signals are high and drive is in Run state.

Reference is anyway limited between P 3.1 and P 3.2 values.

P3.17 MOTPOT COPY REF

In case the reference is restored to motorpotentiometer, after a preset speed, P3.17 defines the initial value for the reference.

0: keep memory of reference previously reached with motpot control

1: start from actual reference

P3.18 MOTOR POTENTIOMETER MEMORY

0: No reset

1: Reset at stop or power down

2: Reset at power down

Note: memory of motopotentiometer is reset if both Inc and Dec signals are high for at least 3 seconds, when drive is in Stop state.

P3.19 MANUAL REFERENCE SELECTION

Defines the source of frequency reference in Manual.

0: Preset speed

1: Panel potentiometer

2: Preset + Potent adjust (potentiometer adjusts preset speed)

P3.20 MANUAL PRESET SPEED

Basic preset reference for manual mode

P3.21 PANEL POTENTIOMETER MIN FREQ**P3.22 PANEL POTENTIOMETER MAX FREQ**

Define the minimum and maximum reference controlled with potentiometer on panel.

P3.23 PANEL POTENTIOMETER MIN CORRECTION**P3.24 PANEL POTENTIOMETER MAX CORRECTION**

Define the minimum and maximum correction on preset reference, controlled with potentiometer on panel.

3.4 RAMPS**P4.1 ACCELERATION TIME 1**

Ramp time, referred to variation from zero frequency to max frequency.

P4.2 DECELERATION TIME 1

Ramp time, referred to variation from max frequency to zero.

P4.3 RAMP 1 S SHAPE

When value is greater than zero, acceleration and deceleration ramps have a S shape.

The parameter is the time needed to reach full acc/dec.

When value is greater than zero, acceleration and deceleration ramps have a S shape. The parameter is the time needed to reach full acc/dec.

The start and end of acceleration and deceleration ramps can be smoothed with this parameter. Setting value 0 gives a linear ramp shape which causes acceleration and deceleration to act immediately to the changes in the reference signal.

Setting value 0.1...10 seconds for this parameter produces an S-shaped acceleration/deceleration. The acceleration time is determined with parameters P1.3 and P1.4.

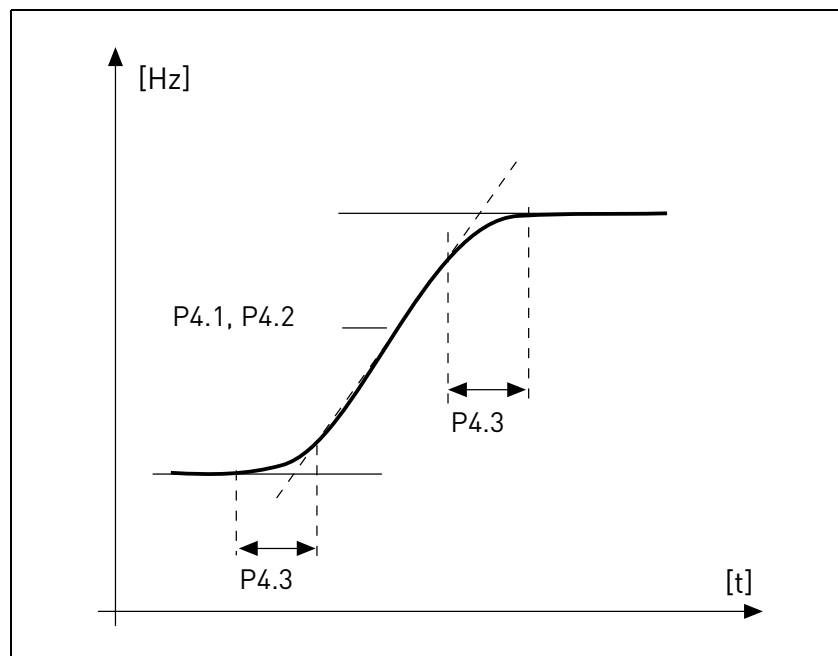


Figure 5. Acceleration/deceleration (S-shaped).

These parameters are used to reduce mechanical erosion and current spikes when the reference is changed.

P4.4 ACCELERATION TIME 2**P4.5 DECELERATION TIME 2****P4.6 RAMP 2 S SHAPE**

Ramp 2 is available only in Automatic mode, and is activated through digital signal defined in P5.11. Automatic activation based on output frequency is also available.

P4.7 THRESHOLD ACCELERATION TIME 2**P4.8 THRESHOLD DECELERATION TIME 2**

If P4.7 is not 0, acceleration time 2 is activated when output frequency is higher than the value.

If P4.8 is not 0, deceleration time 2 is activated when output frequency is higher than the value.

P4.9 QUICK STOP DECELERATION TIME

Specific ramp time for quick stop. To see description of P2.5 for details about the function.

3.5 INPUT FUNCTIONS

P5.1 START SIGNAL 1

P5.2 START SIGNAL 2

Signals for start and direction. Logic is selected with P2.1.

0: Function not used

1: ASi Output 1

2: ASi Output 2

3: ASi Output 3

4: ASi Output 4

5: Sensor 1

6: Sensor 2

7: Sensor 3

8: Sensor 4

P5.3 PRESET SPEED BIT0

P5.4 PRESET SPEED BIT1

P5.5 PRESET SPEED BIT2

Signals for preset speed selection, with binary coding.

Required action			Activated frequency
B2	B1	B0	Preset frequency 0
B2	B1	■ B0	Preset frequency 1
B2	■ B1	B0	Preset frequency 2
B2	B1	■ B0	Preset frequency 3
■ B2	B1	B0	Preset frequency 4
B2	■ B1	■ B0	Preset frequency 5
B2	B1	■ B0	Preset frequency 6
■ B2	■ B1	■ B0	Preset frequency 7

Table 45. Selection of preset frequencies; ■ = input activated

P5.6 FAULT RESET

Active on rising edge.

Note: an automatic fault reset is triggered when Manual mode is activated on operator panel.

P5.7 FORCE BRAKE

Signal high opens the mechanical brake.

P5.8 EXTERNAL FAULT, CLOSE

Fault is triggered by high signal.

P5.9 EXTERNAL FAULT, OPEN

Fault is triggered by low signal.

P5.10 RUN ENABLE

Motor stops by coasting if the signal is missing.

Note: The drive is not in Ready state when Enable is low.

P5.11 RAMP TIME 2 SELECTION

Ramp 2 is selected by signal high.

P5.12 MOTOR POTENTIOMETER UP

Signal high causes speed increase.

P5.13 MOTOR POTENTIOMETER DOWN

Signal high causes speed reduction.

P5.14 QUICK STOP OPEN

Signal low forces the drive to stop, ramping down with the time defined in P4.9.

To see description of P2.5 for details about the function.

P5.15 QUICK STOP CLOSE

Similar to P5.14, but in this case Quick Stop is activated by high signal.

3.6 OUTPUT FUNCTIONS**P6.1 ASI INPUT 1****P6.2 ASI INPUT 2****P6.3 ASI INPUT 3****P6.4 ASI INPUT 4**

Meaning of ASi input bit.

0: not used

1: Sensor 1

2: Sensor 2

3: Sensor 3

4: Sensor 4

5: Ready + Automatic (both conditions are needed to have the bit high)

6: Run

7: Fault

8: Fault or warning

9: Reverse

10: Running feedback¹⁾

11: Automatic mode

12: At speed (reference reached, from internal motor control)

13: Output freq superv

14: Output current superv

15: Brake command

16: Quick stop active

¹⁾ when Automatic mode is not assigned to a specific Input, Running Feedback input includes also information about Automatic.

Automatic	Run	Output frequency <= Setpoint	Feedback
0	-	-	0
1	0	-	1
1	1	0	0
1	1	1	1

P6.5 RO1 SIGNAL SELECTION**P6.6 RO2 SIGNAL SELECTION**

Function for internal relays.

0: not used

1: Ready

2: Run

3: Fault

4: Fault inverted

5: Fault or warning

6: Reverse

7: At speed (motor control feedback)

8: Output freq superv

9: Output current superv

10: ASi Output 1

11: ASi Output 2

12: ASi Output 3

13: ASi Output 4

Note: relay terminals are not accessible in standard V20X+D drive.

P6.7 RO1 ON DELAY**P6.8 RO1 OFF DELAY**

Possible delays for ON/OFF transitions.

P6.9 RO1 INVERSION

Inversion of relay state.

P6.10 RO2 ON DELAY**P6.11 RO2 OFF DELAY**

Possible delays for ON/OFF transitions.

3.7 MECHANICAL BRAKE

P7.1 BRAKE OPEN FREQUENCY

P7.2 BRAKE OPEN CURRENT

Thresholds that must be reached for external brake open at start.

If P7.1 > 0Hz, frequency reference is internally limited to P7.1 + 0.1 Hz until the brake is released.

Fault 56 Brake Time Out is triggered if the thresholds in P7.1 and P7.2 are not reached within 3s from Start command.

P7.3 BRAKE CLOSE FREQUENCY

The brake is closed when the start command is low and output frequency is below this threshold. Possible delay in P7.4.

P7.4 BRAKE CLOSE DELAY

Respected in any stop condition (quick, fault, no enable), apart direct control from ASi input, when the signal goes low.

3.8 SUPERVISIONS

P8.1 ***RUNNING FEEDBACK TOLERANCE***

When output frequency has reached this percentage of reference, running feedback is set high.

P8.2 ***FREQUENCY SUPERVISION FUNCTION***

- 0: No supervision
- 1: Low limit
- 2: High limit

P8.3 ***FREQUENCY SUPERVISION LIMIT***

Threshold value.

P8.4 ***CURRENT SUPERVISION LIMIT***

Threshold value.

P8.5 ***PROCESS DISPLAY SOURCE***

Monitor V3.9 can show a process value, proportional to a variable measured by the drive. Source variables are:

- 0: output frequency (max: Fmax)
- 1: motor speed (max: Speed at Fmax)
- 2: motor torque (max: Tnom)
- 3: motor power (max: Pnom)
- 4: motor current (max: Inom)

P8.6 ***PROCESS DISPLAY DECIMAL DIGITS***

Number of decimals shown on monitor V3.9 and also on parameter P8.7.

P8.7 ***PROCESS DISPLAY MAX VALUE***

Value shown on V3.9 when source variable is at its maximum. Proportionality is kept if the source overtakes the maximum.

3.9 MOTOR CONTROL

P9.1 FIELD WEAKENING POINT

Output frequency corresponding to max voltage.

Note: if P1.2 Nominal Frequency is changed, P9.1 will be set at same value.

P9.2 FIELD WEAKENING POINT VOLTAGE

Motor voltage when frequency is above FWP, defined as % of nominal voltage.

Note: if P1.1 Nominal Voltage is changed, P9.2 will be set at 100%.

P9.3 U/F SELECTION

0: linear

The voltage of the motor changes linearly as a function of output frequency from zero frequency voltage P9.6 to the field weakening point (FWP) voltage P9.2 at FWP frequency P9.1 This default setting should be used if there is no special need for another setting.

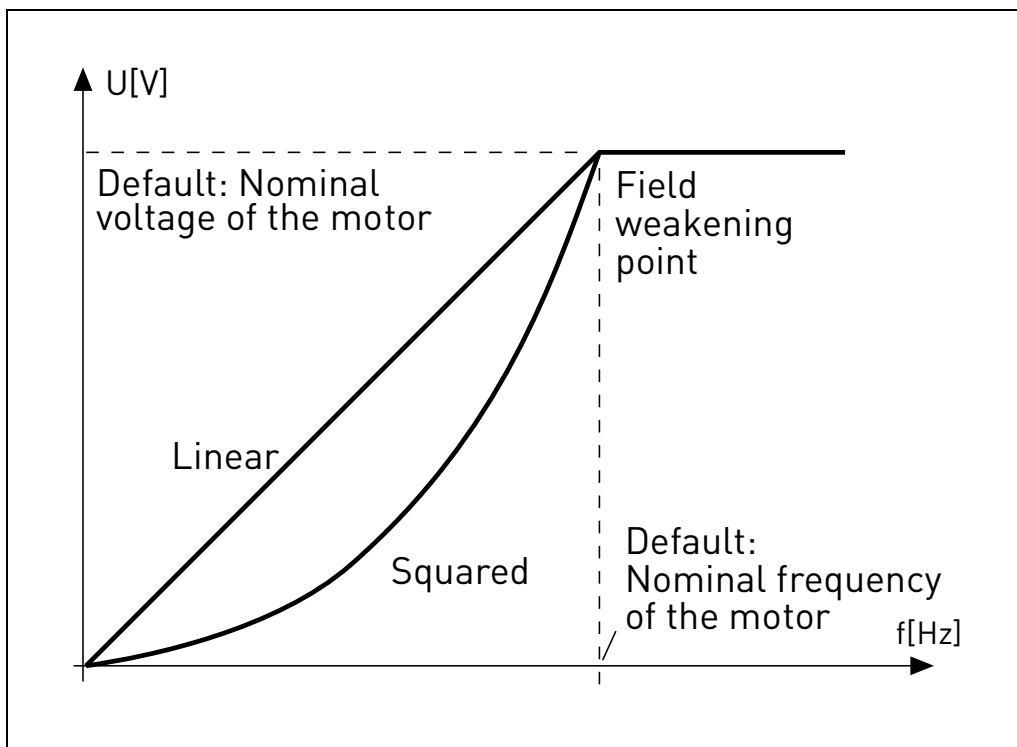


Figure 6. Linear and quadratic curve of the motor voltage.

1: quadratic

(from voltage P9.6 at 0Hz, to voltage P9.2 at P9.1 frequency)

The voltage of the motor changes from zero point voltage P9.6 following a squared curve from zero to the field weakening point P9.2. The motor runs under-magnetized below the field weakening point and produces less torque. Squared U/f ratio can be used in applications where torque demand is proportional to the square of the speed, e.g. in centrifugal fans and pumps.

2: programmable

The U/f curve can be programmed with three different points: Zero frequency voltage (P1), Midpoint voltage/frequency (P2) and Field weakening point (P3).

Programmable U/f curve can be used if more torque is needed at low frequencies. The optimal settings can automatically be achieved with Motor identification run.

Note: motor identification automatically sets this parameter to 2.

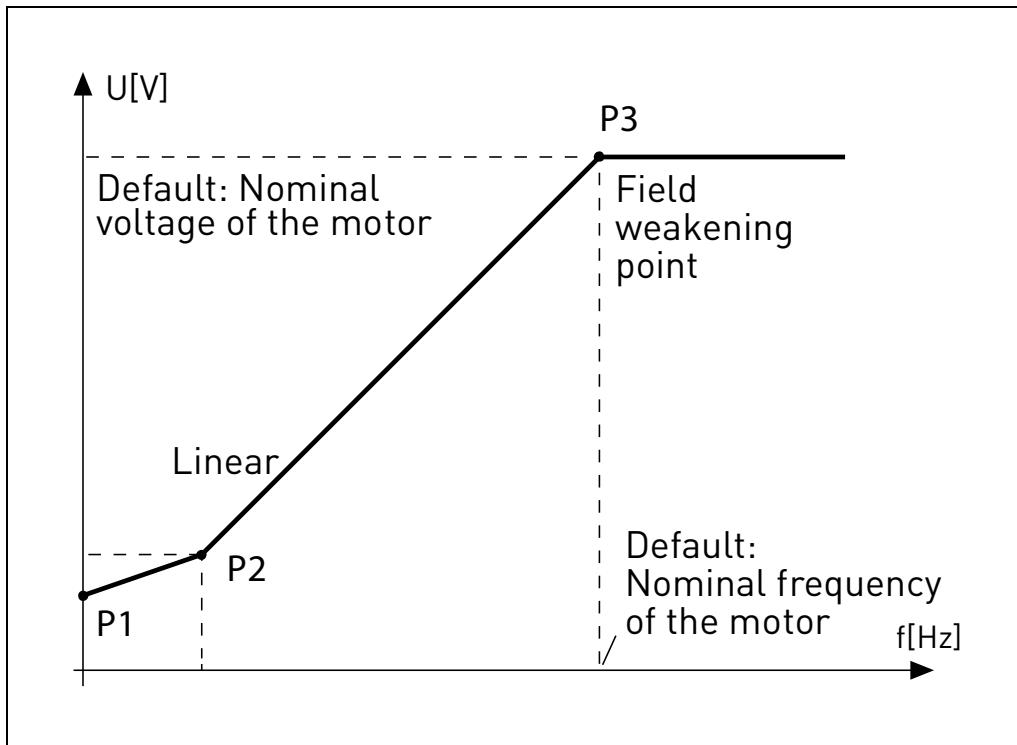


Figure 7. Programmable curve.

P9.4 U/F MID POINT FREQUENCY

Enabled if P9.3= 2.

Note: motor identification automatically sets this parameter.

P9.5 U/F MID POINT VOLTAGE

Enabled if P9.3= 2.

Note: motor identification automatically sets this parameter.

P9.6 VOLTAGE AT F0

Motor voltage at frequency zero.

Note: motor identification automatically sets this parameter.

P9.7 RS VOLTAGE DROP

Voltage drop on stator windings, at motor nominal current, defined as % of nominal voltage. Value affects motor torque estimation, slip compensation and voltage boost.

Note: it is suggested not to program manually the value, but to perform motor identification procedure that automatically sets the value.

P9.8 SWITCHING FREQUENCY

PWM frequency. Values above default can cause thermic overload of the drive.

P9.9 DROOPING MODE

0: constant.

Load drooping factor is constant through the whole frequency range.

1: speed dependent.

Load drooping is reduced linearly from nominal frequency to zero frequency.

P9.10 DROOP FILTER TIME

Time constant of the low pass filter applied to droop frequency variation.

P9.11 BRAKE CHOPPER

0: Chopper disabled

1: Chopper enabled in Run state

2: Chopper enabled in Ready state

P9.12 BRAKE CHOPPER LEVEL

DC link voltage above which chopper is activated.

P9.13 DC BRAKING CURRENT

DC current injected at start or stop.

P9.14 STOP DC CURRENT TIME

Time for DC current injection at stop.

P9.15 STOP DC CURRENT FREQUENCY

DC current is injected below this frequency.

P9.16 START DC BRAKE TIME

Time for DC current injection at start.

P9.17 OVERVOLTAGE REGULATOR

Overvoltage regulator automatically increases deceleration ramp time if the internal DC link voltage is too high.

0: enabled

1: disabled

P9.18 **UNDERVOLTAGE REGULATOR**

Undervoltage regulator automatically decelerates the motor if the internal DC link voltage is too low.

0: enabled

1: disabled

P9.19 **SWITCHING FREQUENCY REGULATOR**

Switching frequency regulator automatically decreases the PWM frequency if the unit temperature is too high.

0: enabled

1: disabled

3.10 PROTECTIONS

P10.1 EARTH FAULT

0: No action

1: Warning

2: Fault

Output currents sum not zero.

P10.2 MOTOR STALL FAULT

0: No action

1: Warning

2: Fault

This is an overload protection. Stall is recognized by maximum motor current (=P1.5) and low output frequency.

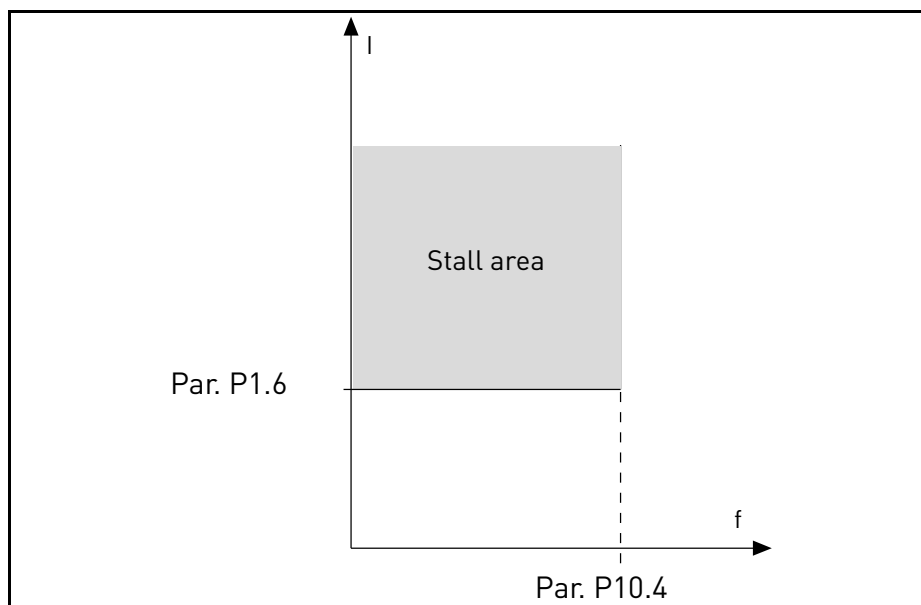


Figure 8. Stall characteristic settings.

P10.3 STALL TIME LIMIT

This time can be set between 0.0 and 300.0 s.

This is the maximum time allowed for all stage. the stall time is counted by an internal up/down counter. If the stall time counter value goes above this limit the protection will cause a trip.

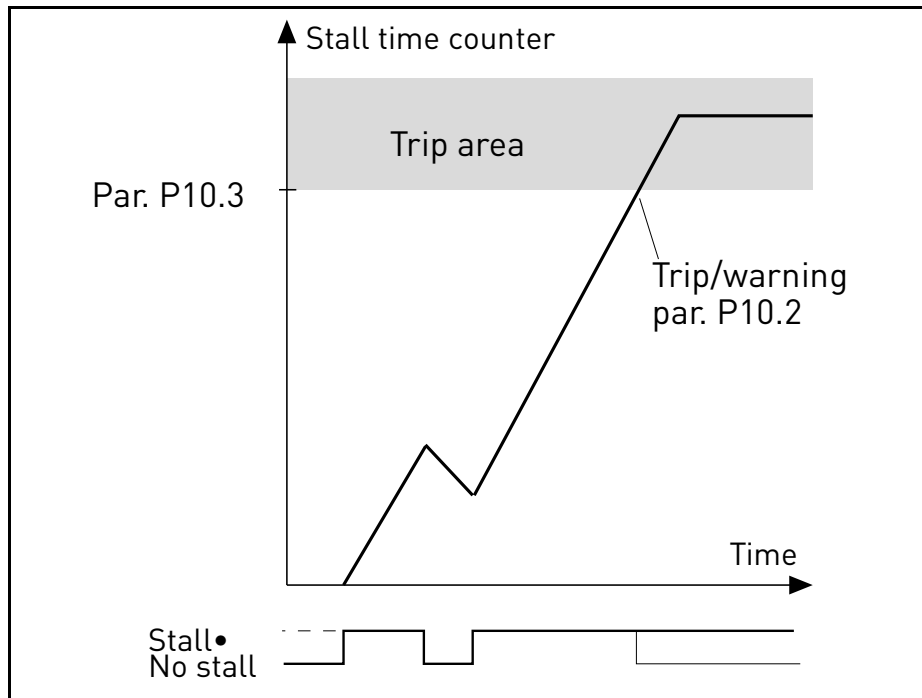


Figure 9. Stall time count.

P10.4 STALL FREQUENCY LIMIT

Stall is recognized when the current limiter has reduced the output frequency below P10.4, for the time in P10.3.

P10.5 UNDERLOAD FAULT

- 0: No action
- 1: Warning
- 2: Fault

Underload is recognized when torque is above the minimum curve defined by P10.6 and P10.7, for the programmed time P10.8.

P10.6 UNDERLOAD FAULT: FIELD WEAKENING AREA LOAD

The torque limit can be set between 10.0-150.0% x T_{nMotor} .

This parameter gives the value for the minimum torque allowed when the output frequency is above the field weakening point.

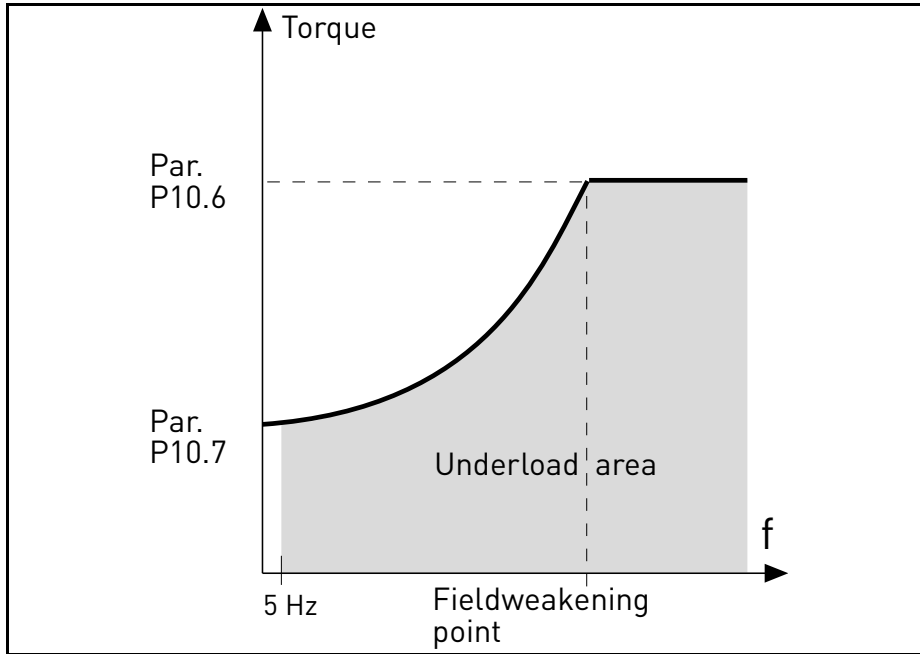


Figure 10. Underload characteristic settings.

P10.7 UNDERLOAD FAULT: ZERO FREQUENCY LOAD

P10.8 UNDERLOAD FAULT: TIME LIMIT

Definition of minimum load at nominal and zero speed zero. Fault condition delay. This time can be set between 1.0 and 300.0 s.

This is the maximum time allowed for an underload state to exist. An internal up/down counter counts the accumulated underload time. If the underload counter value goes above this limit the protection will cause a trip according to parameter P10.5). If the drive is stopped the underload counter is reset to zero.

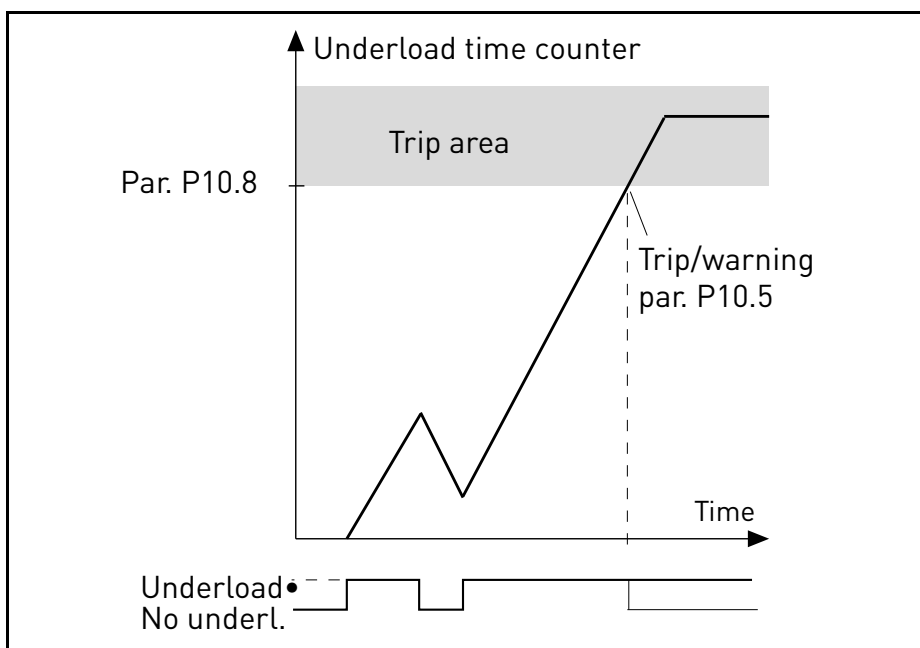


Figure 11. Underload time counter.

P10.9 MOTOR THERMAL FAULT

- 0: No action
- 1: Warning
- 2: Fault

This is a software protection, based on time integral of current.

P10.10 MOTOR AMBIENT TEMPERATURE FACTOR

Change if environment is not standard.

P10.11 MOTOR THERMAL ZERO SPEED COOLING

Defines the cooling factor at zero speed in relation to the point where the motor is running at nominal speed without external cooling. See Figure 12.

The default value is set assuming that there is no external fan cooling the motor. If an external fan is used this parameter can be set to 90% (or even higher).

Setting this parameter does not affect the maximum output current of the drive which is determined by parameter P1.6 alone.

The corner frequency for the thermal protection is 70% of the motor nominal frequency (P1.2).

Set 100% if the motor has independent fan or cooling. Set 30-40% if the fan is on motor shaft.

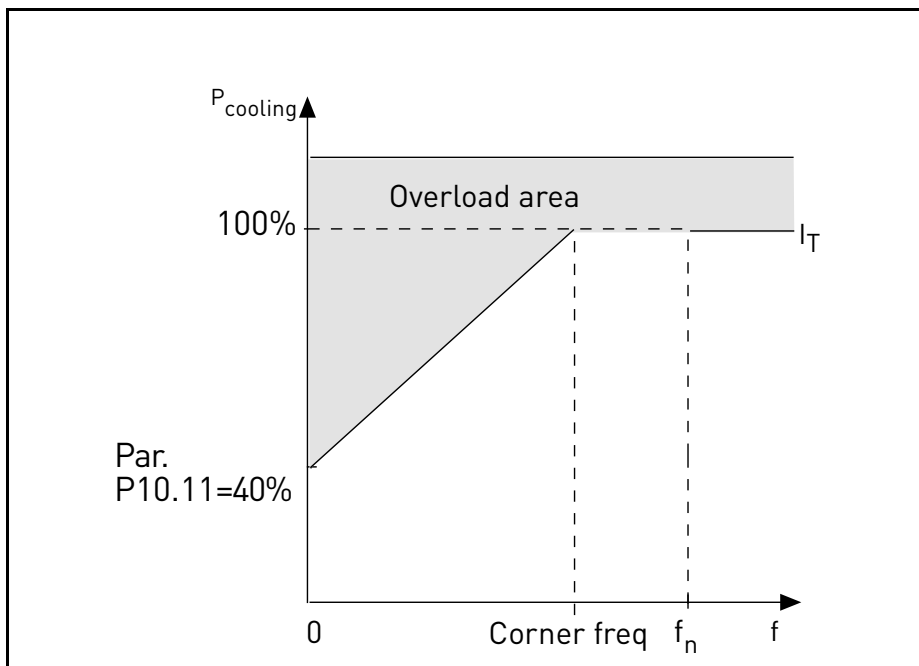


Figure 12. Motor thermal current I_T curve.

P10.12 MOTOR THERMAL TIME CONSTANT

Time at nominal current, to reach nominal temperature.

The time constant is the time within which the calculated thermal stage has reached 63% of its final value. The bigger the frame and/or slower the speed of the motor, the longer the time constant.

The motor thermal time is specific to the motor design and it varies between different motor manufacturers. The default value of the parameter varies from size to size.

If the motor's t_6 -time (t_6 is the time in seconds the motor can safely operate at six times the rated current) is known (given by the motor manufacturer) the time constant parameter can be set basing on it. As a rule of thumb, the motor thermal time constant in minutes equals to $2 \cdot t_6$. If the drive is in stop stage the time constant is internally increased to three times the set parameter value. The cooling in stop stage is based on convection and the time constant is increased.

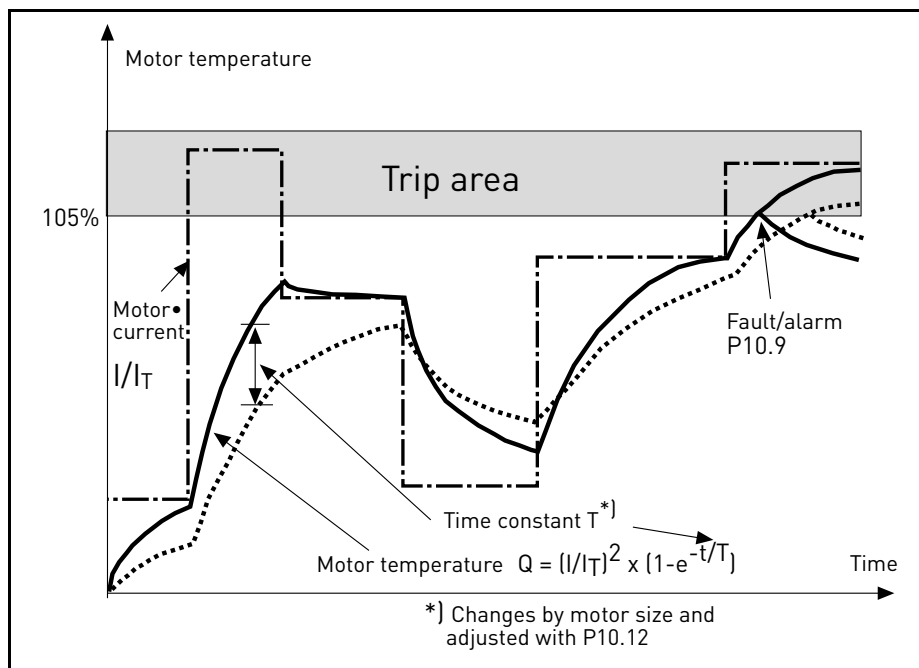


Figure 13. Motor temperature calculation.

P10.13 FIELD BUS COMMUNICATION FAULT

0: No action

1: Warning

2: Fault

Communication lost.

P10.14 THERMISTOR FAULT

0: No action

1: Warning

2: Fault

Impedance on thermistor input is above fault threshold.

P10.15 RESPONSE TO SAFE TORQUE OFF

0: No action
1: Warning
2: Fault, not stored in history
3: Fault, stored in history
Safe Torque Off disabled.

P10.16 INPUT PHASE FAULT

0: No action
1: Warning
2: Fault
Input phase missing.

P10.17 INPUT PHASE FAULT RIPPLE LIMIT

Sensitivity for input phases check
0: internal value (default)
1-75: sensitivity from maximum(1) to minimum (75)

P10.18 MOTOR TEMPERATURE INITIALIZATION

Setting of estimated motor temperature at power on
0: initialized at minimum value
1: initialized at constant value from P10.19
2: initialized at last previous value, with P10.19 used as factor

P10.19 MOTOR TEMPERATURE INITIAL VALUE

If P10.18= 1, motor temperature is initialized with this value.
If P10.18= 2, motor temperature is initialized with last previous value, multiplied by this value as % factor.

3.1.1 AUTOMATIC RESET

P11.1 AUTOMATIC RESET

0: Disabled

1: Enabled

The automatic reset function deletes fault state when the fault cause has been eliminated and the wait time P11.2 has elapsed. Parameter P11.4 determines the maximum number of automatic resets that can be effected during the trial time set by parameter P11.3. The time count starts from the first automatic reset. If the number of faults detected during the trial time exceeds the values of trials, the fault status becomes permanent and a reset command is needed.

P11.2 WAIT TIME

Time after which the converter attempts to restart the motor automatically after the fault has been eliminated.

P11.3 TRIAL TIME

Total time for reset attempts.

P11.4 NUMBER OF TRIALS

Trials attempted during time P11.3.

P11.5 RESTART FUNCTION

Start function after an automatic fault reset.

0: Start with ramp

1: Flying start

2: As defined in P2.3

3.12 NON-ASI FIELDBUS

P12.1 TO

P12.8 *FIELDBUS DATA OUT 1 - 8 SEL*

Parameter couples read only variables to output process data 1.

0: not used

1: output frequency

2: motor speed

3: motor current

4: motor voltage

5: motor torque

6: motor power

7: DC link voltage

8: active fault code

9: ASi inputs (ASi emulation)

10: sensors state (binary)

P12.9 *ASI OUTPUTS EMULATION*

Parameter defines the input process data possibly used to emulate ASi outputs.

0: not used

1: PDI1

2: PDI2

3: PDI3

4: PDI4

5: PDI5

3.12.1 MODBUS FIELDBUS MAPPING**3.12.1.1 Fieldbus Data IN: Master -> Slave**

Modbus register	Name	Description	Range
2001	Control word	Drive control	Binary coded: b0: Run b1: Reverse b2: Fault Reset (on edge)
2002	General control word	Not used	
2003	Speed reference	Reference	0...10000 as 0,00...100,00% of Min freq. - Max freq. range
2004	Fieldbus Data IN 1	Programmable	0...10000 It can emulate ASi Output (See P12.9)
2005	Fieldbus Data IN 2	Programmable	0...10000 It can emulate ASi Output (See P12.9)
2006	Fieldbus Data IN 3	Programmable	0...10000 It can emulate ASi Output (See P12.9)
2007	Fieldbus Data IN 4	Programmable	0...10000 It can emulate ASi Output (See P12.9)
2008	Fieldbus Data IN 5	Programmable	0...10000 It can emulate ASi Output (See P12.9)
2009	Fieldbus Data IN 6	Not used	-
2010	Fieldbus Data IN 7	Not used	-
2011	Fieldbus Data IN 8	Not used	-

Table 46. Modbus Data inputs. They can vary depending on fieldbus used (See specific fieldbus option board installation manual).

Notes:

- CW b0 Run is acquired on edge, only if the drive is in Ready state (see Status Word b0) and actual control place is Fieldbus.
- CW b2 Fault Reset is active even if control place is not the Fieldbus.
- Fieldbus different from Modbus have their own Control Word (see manual of the specific fieldbus board).

3.12.1.2 *Fieldbus Data OUT: Slave ->Master*

Modbus register	Name	Description	Range
2101	Status word	Drive state	Binary coded: b0: Ready b1: Run b2: Reverse b3: Fault b4: Warning b5: Freq. reference reached b6: Zero speed
2102	General Status word	Drive state	b0: Ready b1: Run b2: Reverse b3: Fault b4: Warning b5: Freq. reference reached b6: AUTO mode b7: MANUAL mode b8: Brake command
2103	Actual speed(*)	Actual speed	0...10000 as 0,00...100,00% of Min freq. - Max freq. range
2104	Fieldbus Data OUT 1	Programmable	See P12.1
2105	Fieldbus Data OUT 2	Programmable	See P12.2
2106	Fieldbus Data OUT 3	Programmable	See P12.3
2107	Fieldbus Data OUT 4	Programmable	See P12.4
2108	Fieldbus Data OUT 5	Programmable	See P12.5
2109	Fieldbus Data OUT 6	Programmable	See P12.6
2110	Fieldbus Data OUT 7	Programmable	See P12.7
2111	Fieldbus Data OUT 8	Programmable	See P12.8

Table 47. Modbus data outputs. They can vary depending on fieldbus used (See specific fieldbus option board installation manual).

Notes:

- Fieldbus different from Modbus have their own Status Word (see manual of the specific fieldbus board).

3.13 ANALOGUE OUTPUT

P13.1 ANALOGUE OUTPUT FUNCTION

Signal coupled to analogue output.

Selection	Selection name	Value corresponding to maximum output
0	Not used	output always fixed at 100%
1	Frequency reference	Max frequency(P3.2)
2	Output frequency	Max frequency(P3.2)
3	Motor speed	Motor nominal speed
4	Motor current	Motor nominal current
5	Motor torque	Motor nominal torque (absolute value)
6	Motor power	Motor nominal power (absolute value)

Table 48. Analogue output signals.

P13.2 ANALOGUE OUTPUT MINIMUM SIGNAL

0: 0V

1: 2V

P13.3 ANALOGUE OUTPUT SCALING

Scaling factor.

P13.4 ANALOGUE OUTPUT FILTER TIME

Time constant of low pass filter.

Note: analogue output terminals are not accessible in standard Vacon 20X+D drive.

3.14 USER INTERFACE

P14.1 PARAMETERS ACCESS LEVEL

See chapter 1

0: Basic

1: Advanced

2: Service

P14.2 PARAMETERS LOCK

0: Edit enabled

1: Edit disabled

4. FAULT TRACING

Fault code	Fault name	Possible cause	Remedy
1	Overcurrent	AC drive has detected too high a current ($>4 \cdot I_H$) in the motor cable: <ul style="list-style-type: none"> sudden heavy load increase short circuit in motor cables unsuitable motor 	Check loading. Check motor. Check cables and connections. Make identification run. Check ramp times.
2	Overvoltage	The DC-link voltage has exceeded the limits defined. <ul style="list-style-type: none"> too short a deceleration time brake chopper is disabled high overvoltage spikes in supply Start/Stop sequence too fast 	Make deceleration time longer. Use brake chopper or brake resistor (available as options). Activate overvoltage controller. Check input voltage.
3	Earth fault	Current measurement has detected that the sum of motor phase current is not zero. <ul style="list-style-type: none"> insulation failure in cables or motor 	Check motor cables and motor.
8	System fault	Component fault Malfunction	Reset the fault and restart. Should the fault re-occur, contact the distributor near to you.
9	Undervoltage	DC-link voltage is under the voltage limits defined. <ul style="list-style-type: none"> most probable cause: too low a supply voltage AC drive internal fault defect input fuse external charge switch not closed <p>NOTE! This fault is activated only if the drive is in Run state.</p>	In case of temporary supply voltage break reset the fault and restart the AC drive. Check the supply voltage. If it is adequate, an internal failure has occurred. Contact the distributor near to you.
10	Input phase	Input line phase is missing.	Check supply voltage, fuses and cable.
13	AC drive under-temperature	Too low temperature measured in power unit's heatsink or board. Heatsink temperature is under -10°C .	Check the ambient temperature.
14	AC drive over-temperature	Too high temperature measured in power unit's heatsink or board. Heatsink temperature is over 100°C .	Check the correct amount and flow of cooling air. Check the heatsink for dust. Check the ambient temperature. Make sure that the switching frequency is not too high in relation to ambient temperature and motor load.
15	Motor stalled	Motor is stalled.	Check motor and load.

Table 49. Fault codes and descriptions.

Fault code	Fault name	Possible cause	Remedy
16	Motor overtemperature	Motor is overloaded.	Decrease motor load. If no motor overload exists, check the temperature model parameters.
17	Motor Underload	Motor is under loaded	Check load.
19	Power overload	Supervision for drive power	Drive power is too high: decrease load.
25	Watchdog	Error in the microprocessor monitoring Malfunction Component fault	Reset the fault and restart. If the fault occurs again, please contact your closest Vacon representative.
27	Back EMF	Protection of unit when starting with rotating motor	Reset the fault and restart. Should the fault re-occur, contact the distributor near to you.
30	STO fault	Safe torque off signal does not allow drive to be set as ready	Reset the fault and restart. Should the fault re-occur, contact the distributor near to you.
35	Application error	The application is not working	Please contact your closest Vacon representative.
41	IGBT temp	IGBT temperature (UnitTemperature + I2T) too high	Check loading. Check motor size. Make identification run.
50	4 mA fault (Analog input)	Selected signal range: 4...20 mA (see Application Manual) Current less than 4 mA Signal line broken detached The signal source is faulty	Check the analog input's current source and circuit.
51	External fault	Error message on digital input. The digital input was programmed as an input for external error messages. The input is active.	Check the programming and check the device indicated by the error message. Check the cabling for the respective device as well.
52	Keypad communication fault	The connection between the control keypad and the frequency converter is broken.	Check keypad connection and keypad cable.
53	Fieldbus communication fault	The data connection between the fieldbus master and fieldbus board is broken	Check installation and fieldbus master.
54	Fieldbus Interface error	Defective option board or slot	Check board and slot.
55	Wrong run command	Wrong run alarm and stop command	Run forward and backward are activated at the same time
56	Brake time out	Threshold for brake open are not reached	Check the settings of the mechanical brake and of the motor.
57	Identification	Identification alarm	Motor identification has not been successfully completed

Table 49. Fault codes and descriptions.

Fault code	Fault name	Possible cause	Remedy
63	Quick Stop	Quick Stop activated	The drive has been stopped with Quick Stop digital input or Quick Stop command by fieldbus
64	ASi communication not OK	ASi board is not working properly.	Check the state on monitor V1.3

Table 49. Fault codes and descriptions.

VACON[®]

DRIVEN BY DRIVES

Find your nearest Vacon office
on the Internet at:

www.vacon.com

Document ID:



Manual authoring:
documentation@vacon.com

Vacon Plc.
Runsorintie 7
65380 Vaasa
Finland

Subject to change without prior notice
© 2013 Vacon Plc.

Rev. A