

VACON CX/CXL/CXS FREQUENCY CONVERTERS

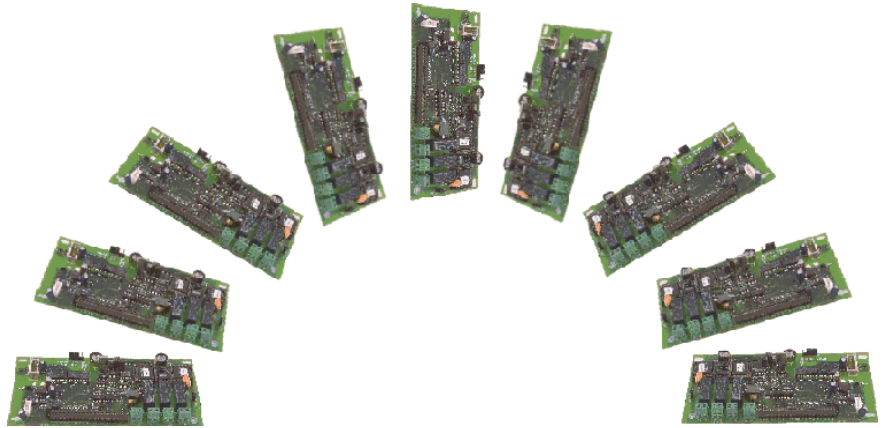

Profibus DP Fieldbus Option Board

USER'S MANUAL

Subject to changes without notice

FOR SMOOTH CONTROL



vacon

INDEX

1. GENERAL	3
2. SPECIFICATIONS	4
2.1 General	4
2.2 Profibus cable	4
3. PROFIBUS DP	6
3.1 General	6
3.2 Profiles	6
4. INSTALLATION	7
5. CONNECTIONS	9
5.1 Board layout	9
5.2 Profibus connections	9
5.3 I/O-control connections	10
6. COMMISSIONING	11
7. PROFIBUS-VACON CX INTERFACE	12
7.1 General	12
7.2 PPO-types	12
7.3 Process Data	15
7.3.1 Control Word	15
7.3.2 Status Word	16
7.3.3 State Machine	16
7.3.4 Speed Reference	17
7.3.5 Actual Value	18
7.3.6 PD1-PD4	18
7.4 Parameter Data	19
7.4.1 Actual Values	19
7.4.2 Parameter Read and Write	20
7.4.3 Fault Code	20
8. FAULT TRACKING	21
9. TYPE FILES	22
9.1 GSD-file	22
APPENDIX A	23
Board layout	23
Profibus connections	23
APPENDIX B	24
APPENDIX C: INSTALLATION	26
Installation of Profibus DP in Vacon CXS drives	26

1. GENERAL

Vacon frequency converters can be connected to the Profibus DP by using a Fieldbus board. The converter can then be controlled, monitored and programmed from the Host system.

The used I/O can also be extended with the Fieldbus board:

- 4 digital inputs (standard signals)
- 4 digital outputs (2 standard signal)
- 1 relay output (standard signal)
- Thermistor input (can be directly connected to the motor thermistors for overtemperature trip)
- Encoder input

The Profibus fieldbus board can be installed inside the frequency converter as instructed in this manual. Note that the installation procedure is different for CX/CXL (board CX202OPT) and CXS frequency converters (CX210OPT).

The control connections are isolated from the mains potential and the I/O ground is connected to the frame of the device via a 1 M Ω resistor and 4.7 nF capacitor*. The control I/O ground can also be connected directly to the frame by changing the position of the jumper X9 (GND ON/OFF) to ON-position. Digital inputs are also isolated from the I/O ground.

NOTE !

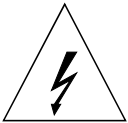

Internal components and circuit boards (except for the isolated I/O terminals) are at mains potential when the frequency converter is connected to the mains. This voltage is extremely dangerous and may cause death or severe injury if you come into contact with it.

The control I/O terminals are isolated from the mains potential, but the I/O:s (if jumper X9 is in OFF-position) may have dangerous voltage connected even if the power is off on the frequency converter.

* Default value = X9 is GND OFF- position)

2. SPECIFICATIONS

2.1 General

Profibus DP - connections	Interface	9-pin DSUB connector (female)
	Transfer method	RS-485, Half duplex
	Transfer cable	Twisted pair (1 pair and shield)
	Electrical isolation	500 V DC
I/O -control connections	Digital input (4 pcs)	24 V: "0" ≤10 V, "1" ≥18 V, R _i = 5 kΩ
	Digital output (4 pcs)	Open collector output, 50 mA/48 V
	Relay output (1 pcs)	Max.switching voltage: 300 V DC, 250 V AC Max.switching load: 8 A / 24 V DC 0,4 A / 300 V AV 2 kVA / 250 V DC Max.continuous load: 2 A rms
	Thermistor input (1 pcs)	R _{trip} = 4.7 kΩ
	Encoder input (3 pcs)	24 V: "0" ≤10 V, "1" ≥18 V, R _i = 3.3 kΩ 5 V: "0" ≤2 V, "1" ≥3 V, R _i = 330 Ω
	Aux. voltage	24 V (±20%), max 50 mA
Safety		Fulfils EN50178 standard

Communication mode	Profibus DP	
PPO types	1	
	2	
	3	
	4	
Communication parameters - Address - Baud Rate	1 to 127	
	9.6 kBaud to 12 MBaud	

Table 2-1. Profibus communication data

2.2 Profibus cable

Profibus devices are connected in a bus structure. Up to 32 stations (master or slaves) can be connected in one segment. The bus is terminated by an active bus terminator at the beginning and end of each segment (see figure 2-1). To ensure error-free operation, both bus terminations must always be powered. When more than 32 stations are used, repeaters (line amplifiers) must be used to connect the individual bus segments.

The maximum cable length depends on the transmission speed and cable type (see table 2-4). The specified cable length can be increased by the use of repeaters. The use of more than 3 repeaters in series is not recommended.

Parameter	Line A	Line B
Impedance	135 ... 165 Ω (3 to 20 Mhz)	100 ... 130 Ω (f > 100kHz)
Capacity	< 30 pF/m	< 60 pF/m
Resistance	< 110 Ω / km	-
Wire gauge	> 0,64 mm	> 0,53 mm
Conductor area	> 0,34 mm ²	> 0,22 mm ²

Table 2-2 Line Parameter

Baud rate (kbit/s)	9.6	19.2	93.75	187.5	500	1500	3000-12000
Length line A (m)	1200	1200	1200	1000	400	200	100
Length line B (m)	1200	1200	1200	600	200	-	-

Table 2-3 Line length for different transmission speeds

Following cables can be used (e.g):

Belden	Profibus Data Cable	3079A
Olflex	Profibus Cable	21702xx
Siemens	SINEC L2 LAN cable for profibus	6XV1 830-0AH10

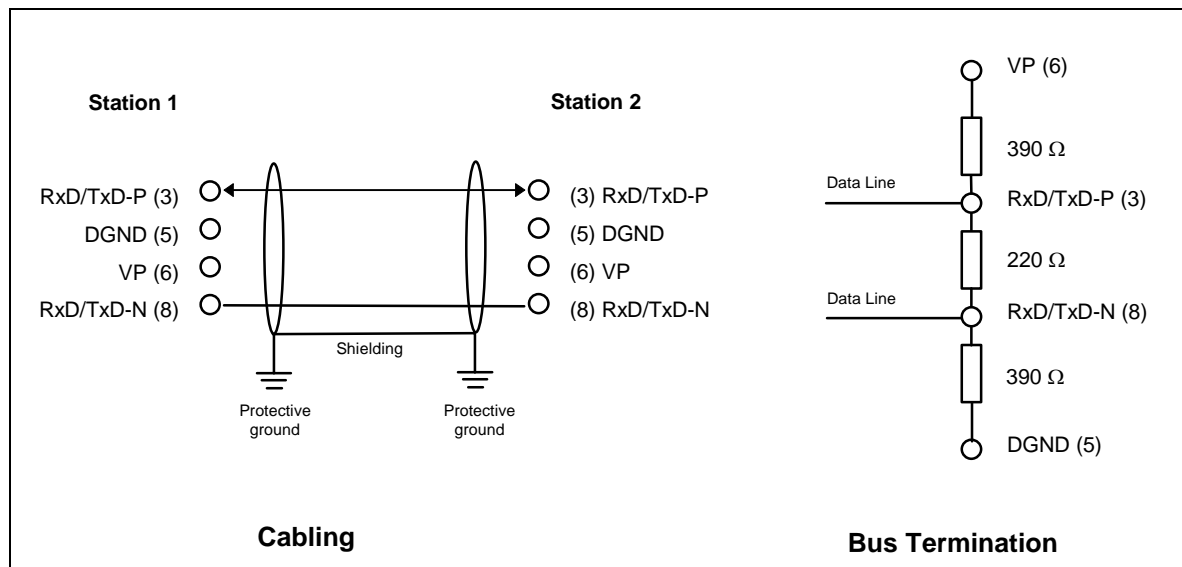

Figure 2-1 Cabling and bus termination

3. PROFIBUS DP

3.1 General

PROFIBUS is a vendor-independent, open fieldbus standard for a wide range of applications in manufacturing, process and building automation. Vendor independence and openness are guaranteed by the PROFIBUS standard EN 50 170. With PROFIBUS, devices of different manufacturers can communicate without special interface adjustments. PROFIBUS can be used for both high-speed time critical data transmission and extensive complex communication tasks. The PROFIBUS family consists of three compatible versions.

PROFIBUS-DP

Optimized for high speed and inexpensive hookup, this PROFIBUS version is designed especially for communication between automation control systems and distributed I/O at the device level. PROFIBUS-DP can be used to replace parallel signal transmission with 24 V or 0 to 20 mA.

PROFIBUS-PA

PROFIBUS-PA is designed especially for process automation. It permits sensors and actuators to be connected on one common bus line even in intrinsically-safe areas. PROFIBUS-PA permits data communication and power over the bus using a 2-wire technology according to the international standard IEC 1158-2.

PROFIBUS-FMS

PROFIBUS-FMS is the general-purpose solution for communication tasks at the cell level. Powerful FMS services open up a wide range of applications and provide great flexibility. PROFIBUS-FMS can also be used for extensive and complex communication tasks.

PROFIBUS specifies the technical and functional characteristics of a serial fieldbus system with which decentralized digital controllers can be networked together from the field level to the cell level. PROFIBUS distinguishes between master devices and slave devices.

Master devices determine the data communication on the bus. A master can send messages without an external request when it holds the bus access rights (the token). Masters are also called active stations in the PROFIBUS protocol.

Slave devices are peripheral devices. Typical slave devices include input/output devices, valves, drives and measuring transmitters. They do not have bus access rights and they can only acknowledge received messages or send messages to the master when requested to do so. Slaves are also called passive stations.

3.2 Profiles

The PROFIBUS-DP protocol defines how user data are to be transmitted between the stations over the bus. User data are not evaluated by the PROFIBUS-DP transmission protocol. The meaning is specified in the profiles. In addition, the profiles specify how PROFIBUS-DP is to be used in the application area. The following PROFIBUS-DP profile is used in VACON CX Profibus fieldbus board.

Variable-Speed Drive Profile (3.071)

Leading manufacturers of drive technology have jointly defined the PROFIDRIVE profile. The profile specifies how the drives are to be parameterized and how the setpoints and actual values are to be transmitted. This enables drives from different vendors to be exchanged. The profile contains necessary specifications for speed control and positioning. It specifies the basic drive functions while leaving sufficient freedom for application-specific expansions and further developments. The profile describes the mapping of the application functions for DP or FMS.

4. INSTALLATION

NOTE! These instructions apply if you have received the Profibus board for Vacon CX or CXL drives (CX202OPT) as an accessory. Otherwise the board has already been installed for you at the factory.

Instructions for the installation of Profibus option board for Vacon CXS drives (CX210OPT) you will find in Appendix C.

Before doing any commissioning, carefully read the safety instructions in the "Vacon CX/CXL/CXS frequency converter, User's manual" chapter "SAFETY". Check that you have received all the Fieldbus board parts: Fieldbus board, plastic board, power cable (black terminal), data cable (blue terminal) and earthing screw.

Fieldbus board can be installed in the place reserved for an option board inside the frequency converter (see figure 4-1).

A	Remove the control panel and jumper X4 from the control board (1).
B	Connect the power cable to control board terminal X5 (2) and the data cable to terminal X14 (3). The power cable can also be connected to terminal X6, if the power cable from the power board is connected to terminal X5.
C	Bend the data cable into an "S-curve" as far as possible from the power board transformer (4) before you place the plastic board above the control board.
D	Remove the protection foil of the plastic board and place the plastic board on the control board, remember the right position of the plastic board (5).
E	Install the Fieldbus board above the plastic board by the larger holes and push it downward so that the narrow part of the hole in the board fits the cut on the sleeve. Check that the installation is stable. If you have difficulties placing the plastic board and the Fieldbus board, slightly bend the regulator A4 (6) and capacitor C59 (7) of the control board.
F	Connect the power cable to terminal X6 of the Fieldbus board (8) and the data cable to the terminal X14 (9).
G	Install the jumper which you removed from the terminal X4 of the control board, on the terminal X9 of the Fieldbus board (10) in ON or OFF position.
H	If the package includes the cable cover (11), fasten it into position as shown in figure 4-1.
I	Install the earthing screw (12).
J	After this install the control panel and connect the needed control signals.
K	If you use a 5 V encoder input, install the jumpers on terminal X15 (see figure 5-1) of the Fieldbus board (one jumper on the two upper pins and the other on the two lower).

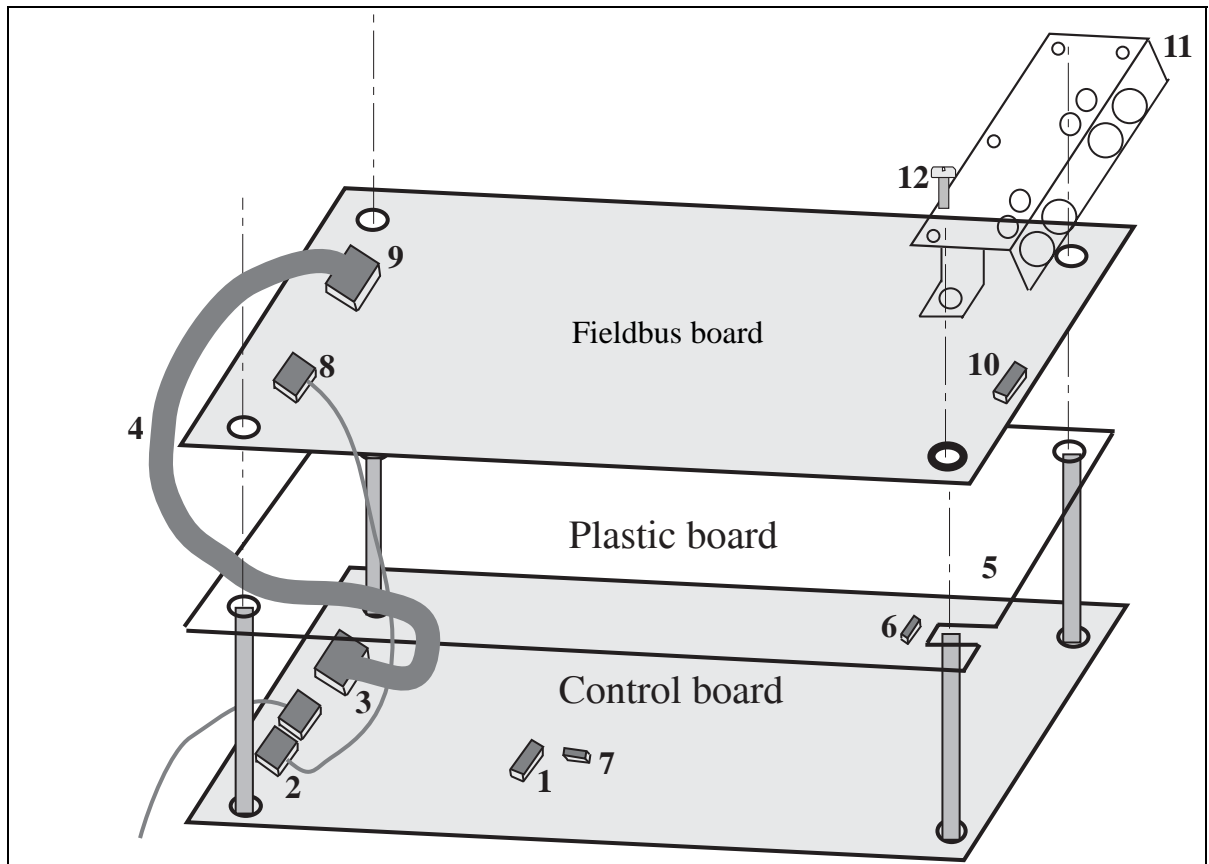
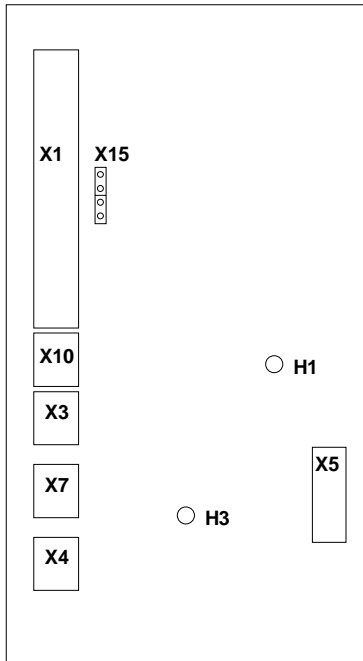

Figure 4-1. Fieldbus board installed onto the control board

5. CONNECTIONS (CX202OPT)

(For the board layout and connections of the small Profibus DP board, Vacon CX210OPT, see Appendix A)

5.1 Board layout



Terminals:

- X1 I/O - terminals
- X10 Digital Output terminal
- X3 Digital Output terminal
- X7 Relay Output terminal
- X4 Thermistor input
- X15 Encoder input selection

- X5 Screw terminal to Profibus DP

- X9 Connection of control I/O ground:
 - ON - Directly to the frame of the device
 - OFF- To the frame of the device via RC filter

- X17 Connection of control Fieldbus shield:
 - ON - Directly to the frame of the device
 - OFF- To the frame of the device via RC filter

Figure 5-1. Fieldbus board

Diagnostic LED:

- H1 Data Exchange state for Profibus DP, Red. The red LED goes out when communication is established
H1 led is active when Fieldbus board is not ready to exchange data
- H3 Supply Voltage, Green.
H3 led is active if the Fieldbus board has supply voltage.

5.2 Profibus connections

Screw Connector connector X5: (Terminal resistors not included in the package)

Signal	Connector X5	Description
Shield	X5-241	Cable shield
VP	X5-242	Supply voltage of the terminating resistance
RxD/TxD-P	X5-243	Receive/Transmission data positive (B)
RxD/TxD-N	X5-244	Receive/Transmission data negative (A)
DGND	X5-245	Data Ground

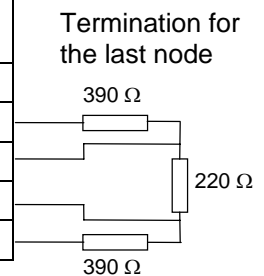

Table 5-1. X5 screw connector terminals

Note! If Vacon is the last device then the bus termination must be set. Install the resistors to the screw terminal (see table 5-1)

5.3 I/O-control connections

Terminal	Signal	Description	
201...205	Not used		
206	+24 V	Control voltage output Voltage for switches, etc. max. 0.05 A	
207	GND	I/O ground Ground for reference and controls	
208	COME	Common for DIE1-DIE4 Connect to GND or +24 V	
209	DIE1	Programmable: External fault OR Selection of active control source	Contact open = no fault Contact closed = fault Contact open = VACON IO-terminal Contact closed = Fieldbus
210	DIE2	Run disable	Contact open = start of motor enabled Contact closed = start of motor disabled
211	DIE3	Acceler. / Decel. time selection	Contact open = time 1 selected Contact closed = time 2 selected
212	DIE4	Jogging speed selection	Contact open = no action Contact closed = jogging speed
213			Not Used
214	DIE6A+	Pulse input A (differential input)	
215	DIE6A-		
216	DIE7B+	Pulse input B (differential input)	90 degrees phase shift compared to pulse input A
217	DIE7B-		
218	DOE1	Encoder direction output	
219	DOE2	Encoder divider 1/64 output	
220			Not Used
221	TI+	Thermistor input	
222	TI-		
225	RO4/1		Relay output 4, FAULT
226	RO4/2		
231	DOE3	Open collector output 3	READY
232	GND	I/O ground	Ground for reference and controls
233	DOE4	Open collector output 4	RUN
234	GND	I/O ground	Ground for reference and controls

Figure 5-2. Control connections

NOTE! Thermistor input (Terminals 221 and 222) must be shorted if not used

READY = ON, when mains voltage has been applied and VACON CX is ready to operate

RUN = ON, when the motor is running

FAULT = ON, if a fault occurs

6. COMMISSIONING

READ FIRST THE COMMISSIONING OF THE FREQUENCY CONVERTER IN VACON CX/CXL/CXS FREQUENCY CONVERTER USER'S MANUAL (CHAPTER 8.)

Commissioning of the Fieldbus board:

Check that Multi-purpose Control Application II (or e.g. Fieldbus Application) is selected.
- Parameter P0.1 = 0

For further information about use of parameters, see Vacon CX/CXL/CXS User's Manual, Chapter 7.

Start-up test:

FREQUENCY CONVERTER APPLICATION

1. Check that the control panel is not the active control source.
(See Vacon CX/CXL/CXS frequency converter User's manual, Chapter 7.)
2. Set parameter "Fieldbus control select" to value 1(On).

MASTER SOFTWARE

1. Set Control Word value to **0hex**.
2. Set Control Word value to **47Fhex**.
3. Frequency converter status is RUN
4. Set Reference value to **5000** (=50,00%).
5. The Actual value is 5000 and the frequency converter output frequency is 25,00 Hz
6. Set Control Word value to **7Dhex**.
7. Frequency converter status is STOP

If Status Word bit 3 = 1 Status of frequency converter is FAULT.

7. PROFIBUS-VACON CX INTERFACE

Features of the Profibus-Vacon CX interface:

- Direct control of Vacon CX (e.g. Run, Stop, Direction, Speed reference, Fault reset)
- Full access to all Vacon CX parameters
- Monitor Vacon CX status (e.g. Output frequency, Output current, Fault code ..)

7.1 General

Data transfer between Profibus DP master and slave takes place via the Input/Output data field. The master writes to slave's Output data and the slave answers by sending the contents of its Input data to the master. The contents of Input /Output data is defined in a device profile, PROFIDRIVE is the device profile for frequency converters.

The Vacon CX frequency converter can be controlled by Profibus DP master using PPO-types defined in PROFIDRIVE (see next chapter). When fieldbus has been selected as the frequency converter's active control place, the frequency converter's operation can be controlled from the Profibus DP master. Whether or not the active control place is fieldbus, the frequency converter can be monitored and its parameters can be set by the Profibus DP master.

7.2 PPO-types

PPOs (Parameter/Process Data Object) are communication objects in PROFIBUS DP. PPOs in VACON CX:

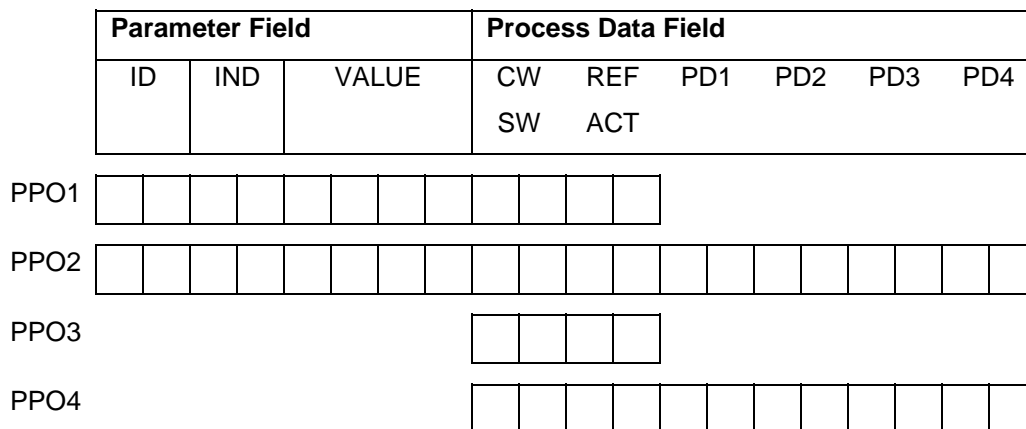

Byte

- ID Parameter type and number
- IND Parameter subindex
- VALUE Parameter value
- CW Control Word
- SW Status Word
- REF Reference Value
- ACT Actual Value
- PD Process Data

ID

ID byte1								ID byte2							
15	14	13	12	11	10	9	8	7	6	5	4	3	2	1	0
Request/Response type				SM		Parameter Number									

SM: Spontaneous bit (not used)

Request/Response types

Request	Function
0	No request
1	Read parameter value (word)
2	Write parameter value (word)

Response	Function
0	No response
1	Parameter value ready (word)
7	Request rejected (+fault code)

Fault Number (if response = 7)

Fault Number	Description
0	Illegal Parameter
1	Parameter is read only (e.g. actual values)
2	Parameter value is out of limits
17	Request temporarily rejected (e.g. can be changed only for STOP state)
18	Other fault
101	Unknown request type

Example1, (PPO1 mode):

Read parameter number 102 (Par 1.2).

Start frequency converter and set speed reference 50,00%.

Command Master - Slave:

ID	1066 hex	1 - Read parameter value
		066 - Parameter 102 (= Maximum frequency)
IND	0000 hex	0000 - No meaning
VALUE	0000 0000 hex	0000 0000 - No meaning
CW	047F hex	04 7F- Start command (see chapter control word and state machine)
REF	1388 hex	Speed ref. 50,00% (= 25,00 Hz if parameter min. frequency 0 Hz and max. frequency 50 Hz)

PPO1 frame:

10	66	00	00	00	00	00	00	00	04	7F	13	88
----	----	----	----	----	----	----	----	----	----	----	----	----

Answer Slave - Master:

ID	1066 hex	1 - Parameter value ready 066 - Parameter 102 (= Maximum frequency)
IND	0000 hex	0000 - No meaning
VALUE	0000 0032 hex	0000 0032 - Parameter value = 32hex (50 Hz)
SW	0000 hex	0000 - frequency converter status (see chapter status word and state machine)
ACT	0000 hex	Current speed 0,00% (= 0,00 Hz if parameter min. frequency 0 Hz and max. frequency 50 Hz)

PPO1 frame:

10	66	00	00	00	00	00	32	00	00	00	00
----	----	----	----	----	----	----	----	----	----	----	----

Example 2, (PPO1 mode):

Write to parameter number 701 (Par 7.1) value 2.

Keep Run mode on and Send speed reference 75,00%.

Command Master - Slave:

ID	22BD hex	2 - Write parameter value 2BD - Parameter 701 (= Response to reference fault)
IND	0000 hex	0000 - No meaning
VALUE	0000 0002 hex	0000 0002 - Parameter value
CW	047F hex	04 7F- Start command (see chapter control word and state machine)
REF	1D4C hex	Speed ref. 75,00% (= 37,50 Hz if parameter min. frequency 0 Hz and max. frequency 50 Hz)

PPO1 frame:

22	BD	00	00	00	00	00	02	04	7F	1D	4C
----	----	----	----	----	----	----	----	----	----	----	----

Answer Slave - Master:

ID	12BD hex	1 - Parameter value ready 2BD - Parameter 701 (= Response to reference fault)
IND	0000 hex	0000 - No meaning
VALUE	0000 0032 hex	0000 0032 - Parameter value = 32HEX (50 Hz)
SW	0337 hex	0337- frequency converter status (see chapter status word and state machine)
ACT	09C4 hex	Current speed 25,00% (= 12,50 Hz if parameter min. frequency 0 Hz and max. frequency 50 Hz)

PPO1 frame:

12	BD	00	00	00	00	00	00	03	37	09	C4
----	----	----	----	----	----	----	----	----	----	----	----

7.3 Process Data

Direct control of Vacon CX (e.g. Run, Stop, Direction, Speed reference, Fault reset) and frequency converter status (e.g. Output frequency, Output current, Fault code ..) can be handled by using PPO types 1 to 4.

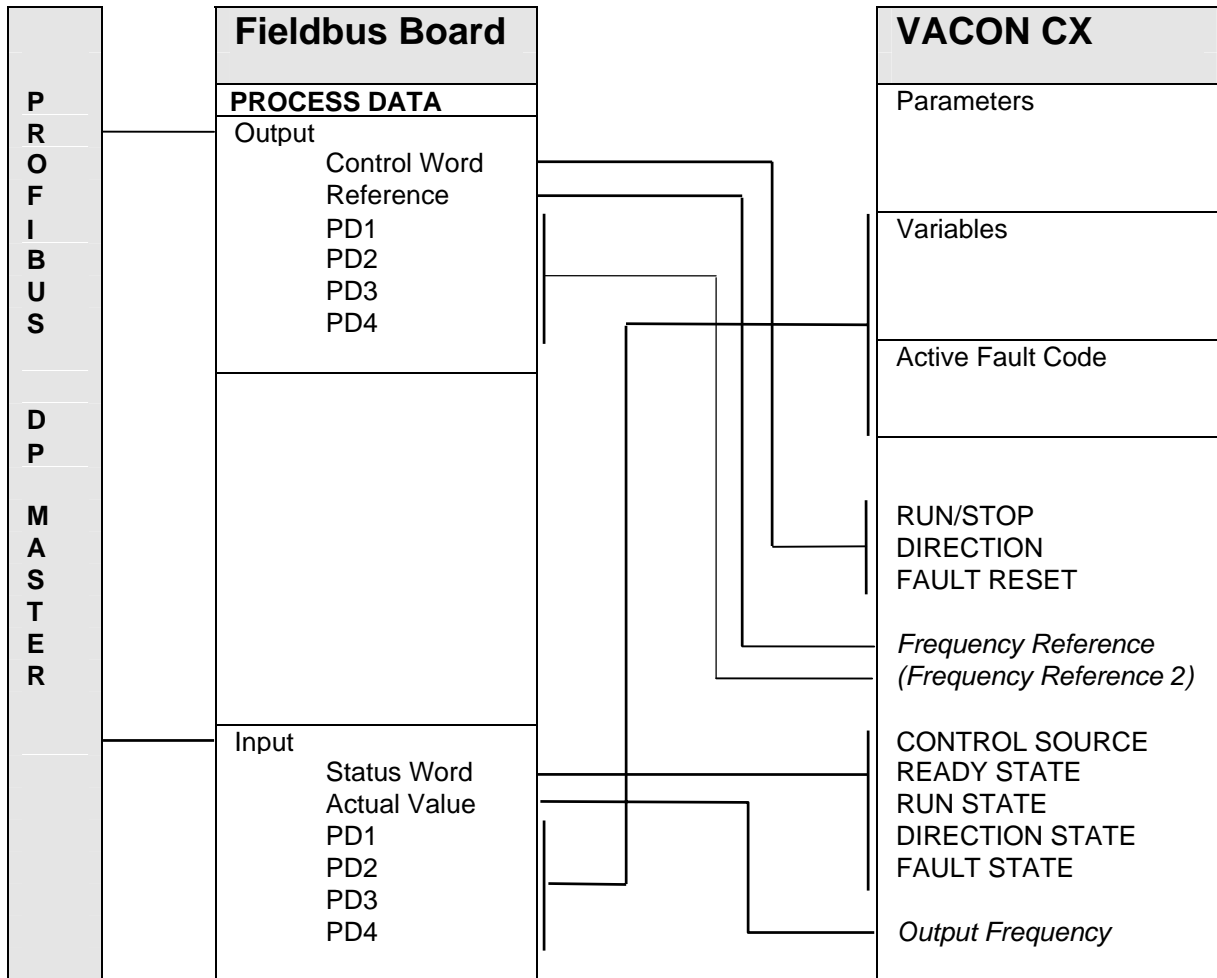

7.3.1 Control Word

The Control command for the state machine (see figure 7.1). The state machine describes the device status and the possible control sequence of the frequency converter.

The control word is composed of 16 bits that have the following meanings:

Bit	Description	
	Value = 0	Value = 1
0	STOP 1 (by ramp)	ON 1
1	STOP 2 (by coast)	ON 2
2	STOP 3 (by ramp)	ON 3
3	RUN DISABLE	ENABLE
4	No Action	START
5	No Action	START
6	No Action	START
7	No Action	FAULT RESET (0 -> 1)
8	No Action	No Action
9	No Action	No Action

10	Disable Profibus control	Enable Profibus control
11	Not used	Not used
12	Not used	Not used
13	Not used	Not used
14	Not used	Not used
15	Not used	Not used

7.3.2 Status Word

Information about the status of the device and messages is indicated in the status word. The status word is composed of 16 bits that have the following meanings:

Bit	Description	
	Value = 0	Value = 1
0	Not Ready (initial)	READY
1	Not Ready	READY
2	DISABLE	ENABLE
3	NO FAULT	FAULT ACTIVE
4	STOP 2 OFF	STOP 2 ON
5	STOP 3 OFF	STOP 3 ON
6	START ENABLE	START DISABLE
7	No Warning	Warning
8	Reference \neq Actual value	Reference = Actual value
9	Fieldbus control OFF	Fieldbus control ON
10	Not used	Not used
11	Not used	Not used
12	FC stopped	Running
13	Not used	Not used
14	Not used	Not used
15	Not used	Not used

7.3.3 State Machine

The state machine describes the device status and the possible control sequence of the frequency converter. The state transitions can be generated by using "control word" parameter. The "status word" parameter indicates the current status of the state machine. The modes **INIT**, **STOP**, **RUN** and **FAULT** (see figure 7-1) correspond to the actual mode of the Frequency converter.

DISABLE (Bit6=1) is one value of the "status word".
Bit0=0 is one value of the "control word".

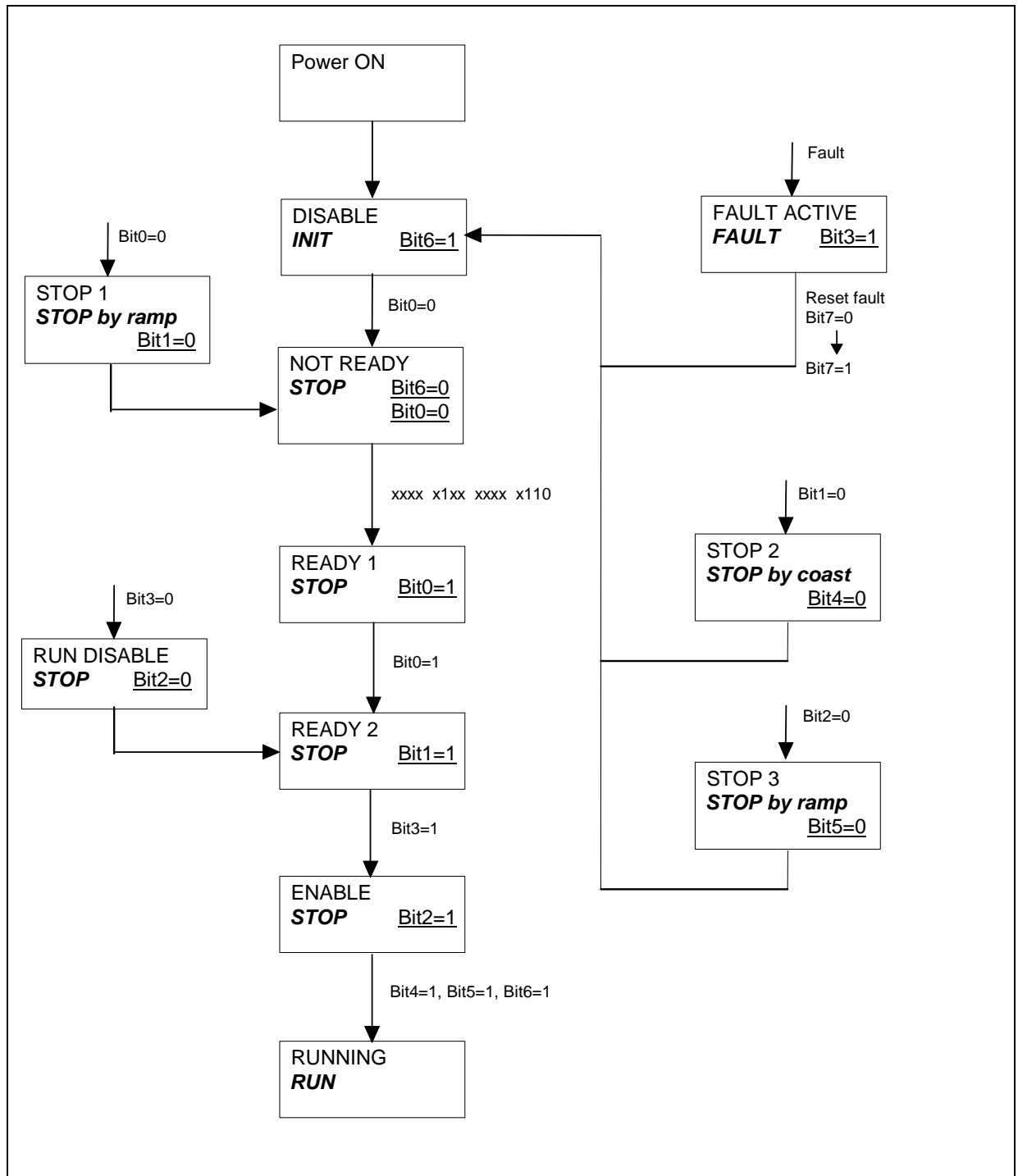

Figure 7-1. States of the device control

7.3.4 Speed Reference

Speed reference of the frequency converter. The range is -10000... 10000, percentage of frequency area between set minimum and maximum frequency.

-10000	=	100,00 %	(Direction reverse)
0	=	0,00 %	(Direction forward)
10000	=	100,00 %	(Direction forward)

7.3.5 Actual Value

Actual value of the motor. The range is -10000... 10000, percentage of frequency area between set minimum and maximum frequency.

-10000	=	100,00 %	(Direction reverse)
0	=	0,00 %	(Direction forward)
10000	=	100,00 %	(Direction forward)

7.3.6 PD1-PD4

The master can read the frequency converter's actual values using process data variables. There are four process data variables and each of them can be selected to show one of the monitoring page variables or active fault code. Selection can be done in two different ways:

By master:	Parameter	916.1	PD1
		916.2	PD2
		916.3	PD3
		916.4	PD4
By control panel:	Parameter	Process Data 1	PD1
		Process Data 2	PD2
		Process Data 3	PD3
		Process Data 4	PD4

Set the number of the variable to be monitored (see table 7-1) or number 99 for the active fault code to the value of the parameter.

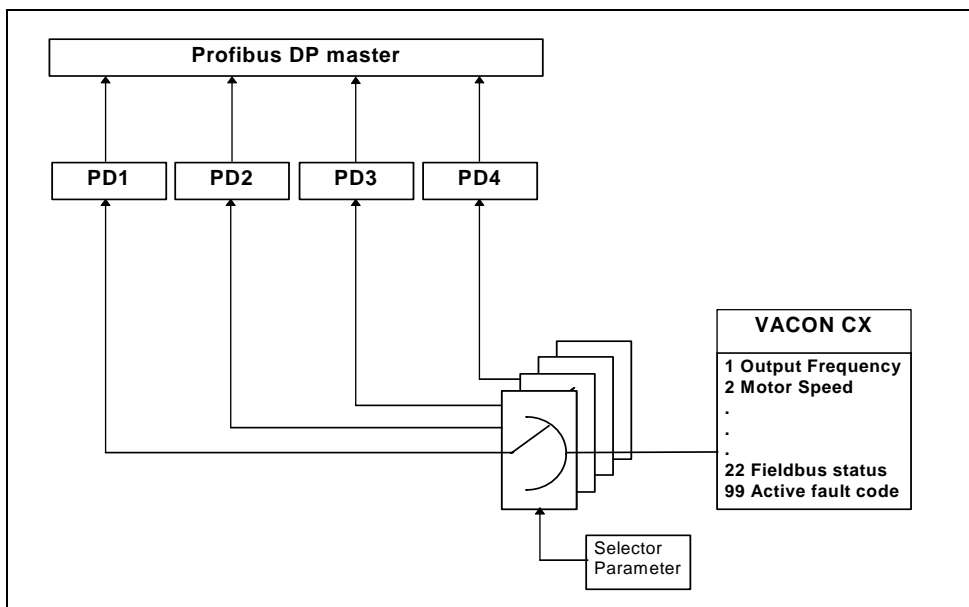
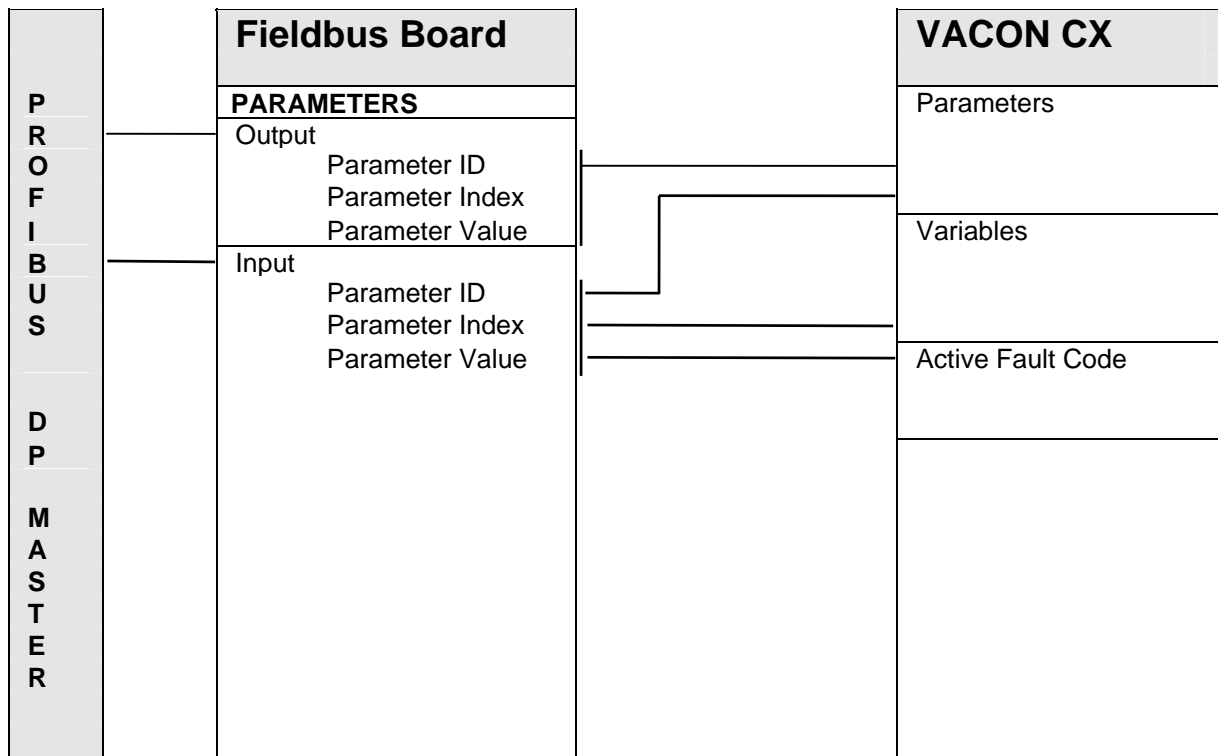

Figure 7-2. Control of Process Data

7.4 Parameter Data



The Vacon variables and fault codes can be read and parameters can be read and written using PPO types 1 and 2.

7.4.1 Actual Values

Actual Values can be read by using the parameter read function.

Profibus parameter numbers according to monitored item numbers are as follows.

Parameter number	Vacon variable
1	n1
2	n2
.	.
.	.
98	n98

Number	Data name	Step	Unit	Description
V1	Output frequency	0,01	Hz	Frequency to the motor
V2	Motor speed	1	rpm	Calculated motor speed
V3	Motor current	0,1	A	Measured motor current
V4	Motor torque	1	%	Calculated actual torque/nominal torque of the unit
V5	Motor power	1	%	Calculated actual power/nominal power of the unit
V6	Motor voltage	1	V	Calculated motor voltage
V7	DC-link voltage	1	V	Measured DC-link voltage
V8	Temperature	1	°C	Temperature of the heat sink

V9	Operating day counter		DD.dd	Operating days 1), not resettable
V10	Operating hours, "trip counter"		HH.hh	Operating hours 2), can be reset with program-button #3
V11	MW-hours	0,001	MWh	Total amount of MW-hours, not resettable
V12	MW-hours, "trip counter"	0,001	MWh	MW-hours, can be reset with programmable button #4
V13	Voltage/analogue input	0,01	V	Voltage of the terminal U _{IN+} (control board)
V14	Current/analogue input	0,01	mA	Current of terminals I _{IN+} and I _{IN-} (control board)
V15	Digital input status, gr. A			0 = Open Input, 1 = Closed Input (Active)
V16	Digital input status, gr. B			0 = Open Input, 1 = Closed Input (Active)
V17	Digital and relay output status			0 = Open Input, 1 = Closed Input (Active)
V18	Control program			Version number of the control software
V19	Unit nominal power	0,1	kW	Shows the power size of the unit
V20	Motor temperature rise	1	%	100% = temperature of motor has risen to nominal value

Table 7-1 Monitored Items

1) DD = full days, dd = decimal part of a day

2) HH = full hours, hh = decimal part of an hour

For Special Actual Values see Appendix B.

7.4.2 Parameter Read and Write

The Vacon variables and parameters can be read and written using the Parameter Read/Write function.

Profibus parameters according to parameter numbers are as follows.

Parameter Number	Vacon parameter group	Vacon parameter number
101 - 199	Group 1	1 - 99
201 - 299	Group 2	1 - 99
.	.	
.	.	
801 - 899	Group 8	1 - 99
901 - 999	Profibus DP parameter	
1001 - 1099	Group 9	1 - 99
.	.	
.	.	
1901 - 1999	Group 18	1 - 99

Numbering of the parameter as well as parameter ranges and steps can be found in the application manual in question. The parameter value should be given without decimals. The Profibus DP parameter group can be set by the Profibus DP master only, not on the VACON CX control panel.

7.4.3 Fault Code

When a fault is active, fault codes can be read using the Parameter Read function. Profibus parameter number according to the fault code is as follows.

Parameter number	Vacon variable
99	Active fault code

List and description of the fault codes are in *VACON CX/CXL/CXS USER'S MANUAL*

8. FAULT TRACKING

Fault Type	Possible cause	Checking
Fault 19 is active in Vacon CX	The data cable connection between control board and fieldbus board is not working	Check the installation - if installation is correct contact the nearest Vacon distributor
Fault 27 is active in Vacon CX	Profibus DP Master is not active and the control source is fieldbus	Check the system Master device
UL led is not active (Supply Voltage, Green).	The power cable connection between control board and fieldbus board is not working	Check the installation - if installation is correct contact the nearest Vacon distributor
DE led is active (Data Exchange not Ready) and actual value n22 = 0	Fieldbus board has not received a parameterization telegram or the telegram is incorrect.	Check the configuration in the Profibus DP master.
	Bus wire break	Check the bus cables
DE led is active (Data Exchange not Ready) and actual value n 22 = 1	Fieldbus board has not received a configuration telegram or the telegram is incorrect.	Check the type files (GSD)

9. Type Files

9.1 GSD-file

```
#Profibus_DP
GSD_Revision           = 1
Vendor_Name            = "Vaasa Control"
Model_Name             = "Vacon CX202OPT"
Revision               = "1.0"
Ident_Number          = 0x9500
Protocol_Ident        = 0
Station_Type          = 0
FMS_supp              = 1
Hardware_Release      = "HW1.0"
Software_Release      = "SW1.0"
9.6_supp              = 1
19.2_supp             = 1
93.75_supp            = 1
187.5_supp            = 1
500_supp              = 1
1.5M_supp             = 1
3M_supp               = 1
6M_supp               = 1
12M_supp              = 1
MaxTsdr_9.6          = 60
MaxTsdr_19.2         = 60
MaxTsdr_93.75        = 60
MaxTsdr_187.5        = 60
MaxTsdr_500          = 100
MaxTsdr_1.5M         = 150
MaxTsdr_3M           = 250
MaxTsdr_6M           = 450
MaxTsdr_12M          = 800
Redundancy            = 0
Repeater_Ctrl_Sig    = 0
24V_Pins              = 0
Implementation_Type   = "Profibus for Vacon CX  "
Freeze_Mode_supp     = 1
Sync_Mode_supp       = 1
Auto_Baud_supp       = 1
Set_Slave_Add_supp   = 0
Min_Slave_Intervall  = 20
Modular_Station      = 1
Max_Module            = 4
Max_Input_Len        = 20
Max_Output_Len       = 20
Max_Data_Len         = 40
Modul_Offset         = 0
Fail_Safe             = 1
Max_Diag_Data_Len    = 6
Module = "VACON PPO 1" 0xF3, 0xF1
EndModule;
Module = "VACON PPO 2" 0xF3, 0xF5
EndModule;
Module = "VACON PPO 3" 0xF1
EndModule;
Module = "VACON PPO 4" 0xF5
EndModule;
```

APPENDIX A

CONNECTIONS (small Profibus DP Board, Vacon CX210OPT)

Board layout

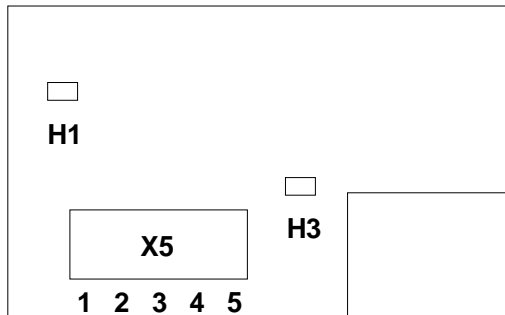

Figure 1. Profibus board

Terminals:

X5 Screw terminal to Profibus DP

Diagnostic LED:

H1 Data Exchange state for Profibus DP, Red.
 H1 led is active when Fieldbus board is not ready to exchange data

H3 Supply Voltage, Red.
 H3 led is active if the Fieldbus board has supply voltage.

Profibus connections

Screw Connector connector X5: (Terminal resistors not included in the package)

Signal	Connector X5	Description
Shield	X5-1	Cable shield
VP	X5-2	Supply voltage of the terminating resistance
RxD/TxD-P	X5-3	Receive/Transmission data positive (B)
RxD/TxD-N	X5-4	Receive/Transmission data negative (A)
DGND	X5-5	Data Ground

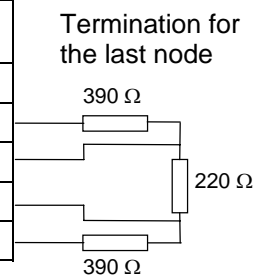

Table 1. D-sub connector

Note! If Vacon is the last device then the bus termination must be set. Install the resistors to the screw terminal (see table 5-1)

APPENDIX B

Special Actual Values

By default, the *Actual Value* corresponds to the motor rotation speed in percentage.

Actual Value can be attached some other monitored variable. Meaning of *Actual Value* can be selected by resetting a Control Word bits 15...11. The user can choose to show one of the monitoring page variables or the active fault code.

Control Word (bits 15...11) is binary coded as follows:

Control Word					Description
bit 15	bit 14	bit 13	bit 12	bit 11	
0	0	0	0	0	Default, Actual Speed (%)
0	0	0	0	1	V1 (see table 0-1)
0	0	0	1	0	V2 (see table 0-1)
0	0	0	1	1	V3 (see table 0-1)
					.
					.
1	1	1	0	1	V29 (see table 0-1)
1	1	1	1	0	Active Fault Code
1	1	1	1	1	Default, Actual Speed (%)

NOTE: The minimum interval allowed to change the bits above is 500ms!

#	Data name	Step	Unit	Description
V1	Output frequency	0,01	Hz	Frequency to the motor
V2	Motor speed	1	rpm	Calculated motor speed
V3	Motor current	0,1	A	Measured motor current
V4	Motor torque	1	%	Calculated actual torque/nominal torque of the unit
V5	Motor power	1	%	Calculated actual power/nominal power of the unit
V6	Motor voltage	1	V	Calculated motor voltage
V7	DC-link voltage	1	V	Measured DC-link voltage
V8	Temperature	1	°C	Temperature of the heat sink
V9	Operating day count		DD.dd	Operating days ¹⁾ , not resetable
V10	Operating hours, "trip counter"		HH.hh	Operating hours ²⁾ , can be reset with program-button #3
V11	MW-hours	0,001	MWh	Total MW-hours, not resetable
V12	MW-hours, "trip counter"	0,001	MWh	MW-hours, can be reset with programmable button #4
V13	Voltage/analogue input	0,01	V	Voltage of the terminal U _{in+} (control board)
V14	Current/analogue input	0,01	mA	Current of terminals I _{in+} and I _{in-} (control board)
V15	Digital input status, gr. A			0 = Open Input, 1 = Closed Input (Active)
V16	Digital input status, gr. B			0 = Open Input, 1 = Closed Input (Active)
V17	Digital and relay output status			0 = Open Input, 1 = Closed Input (Active)
V18	Control program			Version number of the control software
V19	Unit nominal power	0,1	kW	Shows the power size of the unit
V20	Motor temperature rise	1	%	100%= temperature of motor has risen to nominal value

¹⁾ DD = full days, dd = decimal part of a day

²⁾ HH = full hours, hh = decimal part of an hour

APPENDIX C: INSTALLATION

Installation of Profibus DP in Vacon CXS drives

NOTE: The option boards on the pictures may not look exactly the same as the one you have purchased. These instructions are, still, applicable.

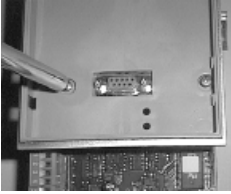
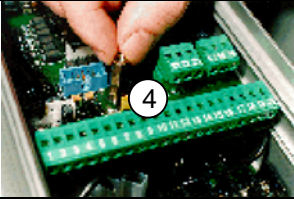
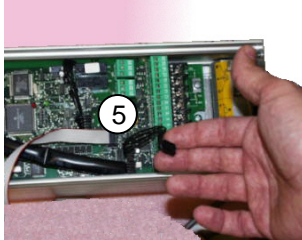
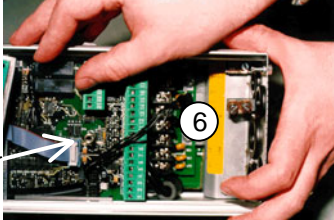
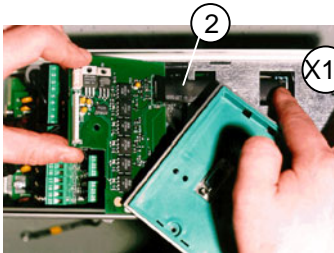
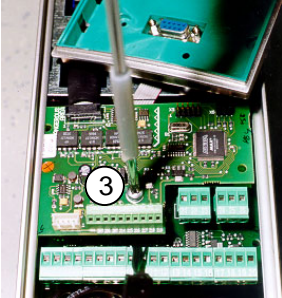
A	Remove the control panel and the panel base. 	
B	Remove the fixing screw from the control board and replace it with a stand sleeve (4). 	
C	Connect the power cable (5) to terminal X5 of the control board. The power cable can also be connected to terminal X6 if terminal X5 is already reserved by the power cable from the power board. 	
D	Remove the protective foil of the plastic board and place the plastic board above the control board. Be sure to place the plastic board correctly so that the stand sleeve (4) comes out through the hole on the board. 	
E	Place the board on the protective plastic board (6) and connect the data cable (2) to terminal X14 of the control board. The stand sleeve should come out through the metal-edged hole. 	
F	Secure the board on the stand sleeve with the screw (3) attached. 	

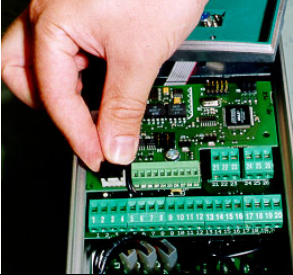
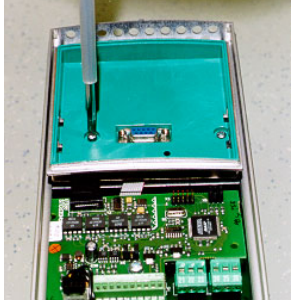
<p>G</p>	<p>Connect the power cable (5) to terminal X9 on the option board.</p>	
<p>H</p>	<p>Attach the control panel base with four screws.</p>	
<p>I Check the connections. Remove all foreign objects from inside the frequency drive. Put the control panel and the frequency drive cover back to their places.</p>		

Vacon Oyj

P.O. Box 25
Runsorintie 7
FIN-65381 VAASA
FINLAND
Phone: +358-201-2121
Fax: +358-201-212 205