



NX FREQUENCY CONVERTERS

MULTI-MOTOR APPLICATION

ALFIFF26

USER'S MANUAL

Vacon Multi-Motor Application (Software ALFIF26) Ver. 1.02

INDEX

1.	INTRODUCTION	3
2.	CONTROL I/O	4
3.	MULTI-MOTOR APPLICATION – PARAMETER LISTS.....	5
3.1	<i>Monitoring values (Control keypad: menu M1).....</i>	<i>5</i>
3.2	<i>Basic parameters (Control keypad: Menu P2 → P2.1).....</i>	<i>6</i>
3.3	<i>Input signals (Control keypad: Menu P2 → P2.2).....</i>	<i>9</i>
3.4	<i>Output signals (Control keypad: Menu P2 → P2.3).....</i>	<i>11</i>
3.5	<i>Drive control parameters (Control keypad: Menu P2 → P2.4).....</i>	<i>12</i>
3.6	<i>Prohibit frequency parameters (Control keypad: Menu P2 → P2.5).....</i>	<i>12</i>
3.7	<i>Motor control parameters (Control keypad: Menu P2 → P2.6).....</i>	<i>12</i>
3.8	<i>Protections (Control keypad: Menu P2 → P2.7)</i>	<i>13</i>
3.9	<i>Autorestart parameters (Control keypad: Menu P2 → P2.8).....</i>	<i>13</i>
3.10	<i>Keypad control (Control keypad: Menu K3).....</i>	<i>14</i>
3.11	<i>System menu (Control keypad: Menu S6).....</i>	<i>14</i>
3.12	<i>Expander boards (Control keypad: Menu E7).....</i>	<i>14</i>
4.	DESCRIPTION OF PARAMETERS	15
4.1	<i>BASIC PARAMETERS.....</i>	<i>15</i>
4.2	<i>INPUT SIGNALS.....</i>	<i>20</i>
4.3	<i>OUTPUT SIGNALS.....</i>	<i>23</i>
4.4	<i>DRIVE CONTROL.....</i>	<i>26</i>
4.5	<i>PROHIBIT FREQUENCIES</i>	<i>29</i>
4.6	<i>MOTOR CONTROL.....</i>	<i>30</i>
4.7	<i>PROTECTIONS.....</i>	<i>31</i>
4.8	<i>AUTO RESTART PARAMETERS.....</i>	<i>38</i>
4.9	<i>KEYPAD CONTROL PARAMETERS.....</i>	<i>39</i>

Multicontrol Application

1. Introduction

The Multi-Motor Application for Vacon NXL is based on NXL Multi-Control Application. PID-control, PFC and motor potentiometer-feature are removed. The purpose of this application is to use two different parameter sets, which are selected using digital input. When the drive is commissioned, the only visible parameter group is P2.1 (Basic parameters). The special parameters can be browsed and edited after changing the value of par. [2.1.11](#) (Parameter conceal).

The direct frequency reference can be selected from the analogue inputs, fieldbus, keypad or using preset speeds.

- Digital inputs DIN2, DIN3, (DIN4) and optional dig. inputs DIE1, DIE2, DIE3 are freely programmable.
- Internal and optional digital/relay and analogue outputs are freely programmable.
- Analogue input 1 can be programmed as current input, voltage input or **digital input DIN4**.

NOTE! If the analogue input 1 has been programmed as DIN4 with [parameter 2.2.6](#) (AI1 Signal Range), check that the jumper selections (Error! Reference source not found.) are correct.

Additional functions:

- Programmable Start/Stop and Reverse signal logic
- Reference scaling
- 2 Preset speeds
- Analogue input range selection, signal scaling, inversion and filtering
- Frequency limit supervision
- Programmable start and stop functions
- DC-brake at start and stop
- Prohibit frequency area
- Programmable U/f curve and U/f optimisation
- Adjustable switching frequency
- Autorestart function after fault
- Protections and supervisions (all fully programmable; off, warning, fault):
 - Current input fault
 - External fault
 - Output phase
 - Under voltage
 - Earth fault
 - Motor thermal, stall and underload protection
 - Thermistor
 - Fieldbus communication
 - Option board

2. Control I/O

Reference potentiometer

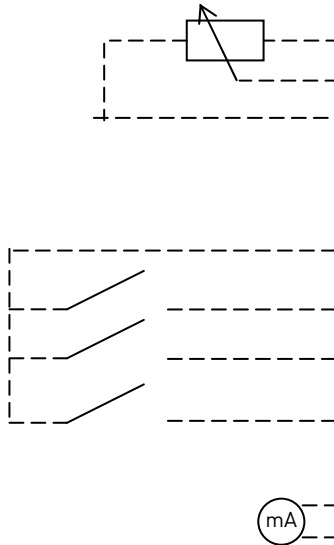

Terminal	Signal	Description
1	+10V _{ref}	Reference output
2	AI1+	Analogue input, voltage range 0—10V DC.
3	AI1-	I/O Ground
4	AI2+	Analogue input, voltage range 0—10V DC, or current range 0/4—20mA
5	AI2- /GND	
6	+24V	Control voltage output
7	GND	I/O ground
8	DIN1	Start forward
9	DIN2	Start reverse (programmable)
10	DIN3	Motor parameter set selection (programmable)
11	GND	I/O ground
18	AO1+	Output frequency
19	AO1-	Analogue output
A	RS 485	Serial bus
B	RS 485	Serial bus
30	+24V	24V aux. input voltage
21	RO1	Relay output 1 FAULT
22	RO1	
23	RO1	

Table 1- 1. Multi-Motor application default I/O configuration.

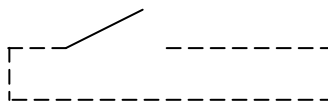

Terminal	Signal	Description
1	+10V _{ref}	Reference output
2	AI1+ or DIN 4	Analogue input, voltage range 0—10V DC
3	AI1-	I/O Ground
4	AI2+	Analogue input, current range 0—20mA
5	AI2- /GND	
6	+ 24 V	Control voltage output
7	GND	I/O ground

Table 1- 2. AI1 configuration, when programmed as DIN4

3. Multi-Motor Application – Parameter lists

On the next pages you will find the lists of parameters within the respective parameter groups. The parameter descriptions are given on pages 15 to 38.

Column explanations:

Code	=	Location indication on the keypad; Shows the operator the present param. number
Parameter	=	Name of parameter
Min	=	Minimum value of parameter
Max	=	Maximum value of parameter
Unit	=	Unit of parameter value; Given if available
Default	=	Value preset by factory
Cust	=	Customer's own setting
ID	=	ID number of the parameter (used with PC tools)
	=	On the parameter code: parameter value can only be changed after the FC has been stopped.

3.1 Monitoring values (Control keypad: menu M1)

The monitoring values are the actual values of parameters and signals as well as statuses and measurements. Monitoring values cannot be edited.

See Vacon NXL User's Manual, Chapter 7.3.1 for more information.

Code	Parameter	Unit	ID	Description
V1.1	Output frequency	Hz	1	Frequency to the motor
V1.2	Frequency reference	Hz	25	
V1.3	Motor speed	rpm	2	Calculated motor speed
V1.4	Motor current	A	3	Measured motor current
V1.5	Motor torque	%	4	Calculated actual torque/nom. torque of the motor
V1.6	Motor power	%	5	Calculated actual power/nom. power of the motor
V1.7	Motor voltage	V	6	Calculated motor voltage
V1.8	DC-link voltage	V	7	Measured DC-link voltage
V1.9	Unit temperature	°C	8	Heat sink temperature
V1.10	Analogue input 1		13	AI1
V1.11	Analogue input 2		14	AI2
V1.12	Analogue output current	mA	26	A01
V1.13	Analogue output current 1, expander board	mA	31	
V1.14	Analogue output current 2, expander board	mA	32	
V1.15	DIN1, DIN2, DIN3		15	Digital input statuses
V1.16	DIE1, DIE2, DIE3		33	I/O expander board: Digital input statuses
V1.17	RO1		34	Relay output 1 status
V1.18	ROE1, ROE2, ROE3		35	I/O exp. board: Relay output statuses
V1.19	DOE 1		36	I/O exp. board: Digital output 1 status
V1.20	Active parameter set		1519	Parameter set, which is used to motor control.

Table 1- 3. Monitoring values

3.2 Basic parameters (Control keypad: Menu P2 → P2.1)

3.2.1 Par. Set 1 (G2.1.1)

Code	Parameter	Min	Max	Unit	Default	ID	Note
P2.1.1.1	Min frequency	0,00	2.1.1.2	Hz	0,00	101	
P2.1.1.2	Max frequency	2.1.1.1	320,00	Hz	50,00	102	NOTE: If f_{max} > than the motor synchronous speed, check suitability for motor and drive system
P2.1.1.3	Acceleration time 1	0,1	3000,0	s	1,0	103	
P2.1.1.4	Deceleration time 1	0,1	3000,0	s	1,0	104	
P2.1.1.5	Current limit	$0,1 \times I_L$	$1,5 \times I_L$	A	I_L	107	NOTE: Formulas apply approximately for frequency converters up to MF3. For greater sizes, consult the factory.
P2.1.1.6	Nominal voltage of the motor	180	690	V	NXL2:230v NXL5:400v	110	
P2.1.1.7	Nominal frequency of the motor	30,00	320,00	Hz	50,00	111	Check the rating plate of the motor
P2.1.1.8	Nominal speed of the motor	300	20 000	rpm	1440	112	The default applies for a 4-pole motor and a nominal size frequency converter.
P2.1.1.9	Nominal current of the motor	$0,3 \times I_L$	$1,5 \times I_L$	A	I_L	113	Check the rating plate of the motor
P2.1.1.10	Motor $\cos\phi$	0,30	1,00		0,85	120	Check the rating plate of the motor
P2.1.1.11	Start function	0	1		0	505	0=Ramp 1=Flying start
P2.1.1.12	Stop function	0	1		0	506	0=Coasting 1=Ramp
P2.1.1.13	U/f optimisation	0	1		0	109	0=Not used 1=Automatic torque boost
P2.1.1.14	U/f ratio selection	0	3		0	108	0=Linear 1=Squared 2=Programmable 3=Linear with flux optim.
P2.1.1.15	U/f curve midpoint frequency	0,00	2.1.1.18	Hz	50,00	604	
P2.1.1.16	U/f curve midpoint voltage	0,00	100,00	%	100,00	605	$n\% \times U_{nmot}$ Parameter max. value = par. 2.1.1.19
P2.1.1.17	Output voltage at zero frequency	0,00	40,00	%	0,00	606	$n\% \times U_{nmot}$
P2.1.1.18	Field weakening point	30,00	320,00	Hz	50,00	602	
P2.1.1.19	Voltage at field weakening point	10,00	200,00	%	100,00	603	$n\% \times U_{nmot}$

Table 1- 4. Motor set 1 parameters G2.1.1

3.2.2 Par. Set 2 (G2.1.2)

Code	Parameter	Min	Max	Unit	Default	ID	Note
P2.1.2.1	Min frequency	0,00	2.1.2.2	Hz	0,00	1500	
P2.1.2.2	Max frequency	2.1.2.1	320,00	Hz	50,00	1501	NOTE: If f_{max} > than the motor synchronous speed, check suitability for motor and drive system
P2.1.2.3	Acceleration time 1	0,1	3000,0	s	1,0	1502	
P2.1.2.4	Deceleration time 1	0,1	3000,0	s	1,0	1503	
P2.1.2.5	Current limit	$0,1 \times I_L$	$1,5 \times I_L$	A	I_L	1504	NOTE: Formulas apply approximately for frequency converters up to MF3. For greater sizes, consult the factory.
P2.1.2.6	Nominal voltage of the motor	180	690	V	NXL2:230v NXL5:400v	1505	
P2.1.2.7	Nominal frequency of the motor	30,00	320,00	Hz	50,00	1506	Check the rating plate of the motor
P2.1.2.8	Nominal speed of the motor	300	20 000	rpm	1440	1507	The default applies for a 4-pole motor and a nominal size frequency converter.
P2.1.2.9	Nominal current of the motor	$0,3 \times I_L$	$1,5 \times I_L$	A	I_L	1508	Check the rating plate of the motor
P2.1.2.10	Motor $\cos\phi$	0,30	1,00		0,85	1509	Check the rating plate of the motor
P2.1.2.11	Start function	0	1		0	1510	0=Ramp 1=Flying start
P2.1.2.12	Stop function	0	1		0	1511	0=Coasting 1=Ramp
P2.1.2.13	U/f optimisation	0	1		0	1512	0=Not used 1=Automatic torque boost
P2.1.2.14	U/f ratio selection	0	3		0	1513	0=Linear 1=Squared 2=Programmable 3=Linear with flux optim.
P2.1.2.15	U/f curve midpoint frequency	0,00	2.1.2.18	Hz	50,00	1514	
P2.1.2.16	U/f curve midpoint voltage	0,00	100,00	%	100,00	1515	$n\% \times U_{nmot}$ Parameter max. value = par. 2.1.2.19
P2.1.2.17	Output voltage at zero frequency	0,00	40,00	%	0,00	1516	$n\% \times U_{nmot}$
P2.1.2.18	Field weakening point	30,00	320,00	Hz	50,00	1517	
P2.1.2.19	Voltage at field weakening point	10,00	200,00	%	100,00	1518	$n\% \times U_{nmot}$

Table 1- 5. Motor set 2 parameters G2.1.2

3.2.3 Basic parameters (Control keypad: Menu P2.1.3 → P2.1.11)

P2.1.3	I/O reference	0	4		0	117	0=AI1 1=AI2 2=Keypad reference 3=Fieldbus reference (FBSpeedReference)
P2.1.4	AI2 signal range	1	4		2	390	Not used if AI2 Custom min <> 0% or AI2 custom max. <> 100% 1=0–20 mA 2=4–20 mA 3=0V – 10V 4=2V – 10V
P2.1.5	Analogue output function	0	8		1	307	0=Not used 1=Output freq. (0– f_{max}) 2=Freq. reference (0– f_{max}) 3=Motor speed (0–Motor nominal speed) 4=Output current (0– I_{nMotor}) 5=Motor torque (0– T_{nMotor}) 6=Motor power (0– P_{nMotor}) 7=Mot. voltage (0– U_{nMotor}) 8=DC-link volt (0– U_{nMotor})
P2.1.6	DIN2 function	0	7		1	319	0=Not used 1=Start Reverse (DIN1=Start forward) 2=Reverse (DIN1=Start) 3=Stop pulse (DIN1=Start pulse) 4=External fault, cc 5=External fault, oc 6=Run enable 7=Preset speed 2
P2.1.7	DIN3 function	0	9		9	301	0=Not used 1=Reverse 2=External fault, cc 3=External fault, oc 4=Fault reset 5=Run enable 6=Preset speed 1 7=Preset speed 2 8=DC-braking command 9=Parameter set selection
P2.1.8	Preset speed 1	0,00	Max. freq.	Hz	10,00	105	
P2.1.9	Preset speed 2	0,00	Max. freq.	Hz	50,00	106	
P2.1.10	Automatic restart	0	1		0	731	0=Not used 1=Used
P2.1.11	Parameter conceal	0	1		1	115	0=All parameters and menus visible 1=Only group P2.1 and menus M1 to H5 visible

Table 1- 6. Basic parameters P2.1.3 -> P2.1.11

3.3 Input signals (Control keypad: Menu P2 → P2.2)

Code	Parameter	Min	Max	Unit	Default	Cust	ID	Note
P2.2.1	Expander board DIE1 function	0	9		7		368	0=Not used 1=Reverse 2=External fault, cc 3=External fault, oc 4=Fault reset 5=Run enable 6=Preset speed 1 7=Preset speed 2 8=DC-braking command 9= Parameter set selection
P2.2.2	Expander board DIE2 function	0	9		4		330	As par. 2.2.1
P2.2.3	Expander board DIE3 function	0	9		9		369	As par. 2.2.1
P2.2.4	DIN4 function (AI1)	0	9		2		499	Used if P2.2.6 = 0 Selections as in par.2.2.1
P2.2.5	AI1 signal selection	0	29		10		377	10=AI1 (1=Local, 0=input 1) 11=AI2 (1=Local, 1= input 2) 20=Exp. AI1 (2=exp.board 0=input 1) 21=Exp AI2 (2=exp.board 1=input 2)
P2.2.6	AI1 signal range	0	4		3		379	0=Digital input 4 1=0mA – 20mA (MF4-->) 2=4mA – 20mA (MF4-->) 3=0V – 10V 4=2V – 10V Not used if AI2 Custom min > 0% or AI2 custom max. < 100% Note! See NXL User's manual, chapter 7.3.6: AI1 mode
P2.2.7	AI1 custom minimum setting	0,00	100,00	%	0,00		380	
P2.2.8	AI1 custom maximum setting	0,00	100,00	%	100,00		381	
P2.2.9	AI1 inversion	0	1		0		387	0=Not inverted 1=Inverted
P2.2.10	AI1 filter time	0,00	10,00	s	0,10		378	0=No filtering
P2.2.11	AI2 signal selection	0			11		388	As par. 2.2.5
P2.2.12	AI2 signal range	1	4		2		390	Not used if AI2 Custom min <> 0% or AI2 custom max. <> 100% 1=0–20 mA 2=4–20 mA 3=0V – 10V 4=2V – 10V
P2.2.13	AI2 custom minimum setting	0,00	100,00	%	0,00		391	
P2.2.14	AI2 custom maximum setting	0,00	100,00	%	100,00		392	
P2.2.15	AI2 inversion	0	1		0		398	0=Not inverted 1=Inverted
P2.2.16	AI2 filter time	0,00	10,00	s	0,10		389	0=No filtering
P2.2.17	Reference scaling minimum value	0,00	P2.2.18		0,00		344	
P2.2.18	Reference scaling maximum value	P2.2.19	320,00		0,00		345	

P2.2.19	Keypad control reference selection	0	4		2		121	0=A11 1=A12 2=Keypad reference 3=Fieldbus reference (FBSpeedreference) 4=Motor potentiometer
P2.2.20	Fieldbus control reference selection	0	4		3		122	See above

Table 1- 7. Input signals, P2.2

3.4 Output signals (Control keypad: Menu P2 → P2.3)

Code	Parameter	Min	Max	Unit	Default	Cust	ID	Note
P2.3.1	Relay output 1 function	0	16		3		313	0=Not used 1=Ready 2=Run 3=Fault 4=Fault inverted 5=FC overheat warning 6=Ext. fault or warning 7=Ref. fault or warning 8=Warning 9=Reversed 10=Preset speed 11=At speed 12=Mot. regulator active 13=OP freq. limit superv.1 14=Control place: IO 15=Thermistor fault/warning 16=Active parameter set
P2.3.2	Expander board relay output 1 function	0	16		2		314	As parameter 2.3.1
P2.3.3	Expander board relay output 2 function	0	16		3		317	As parameter 2.3.1
P2.3.4	Expander board digital output 1 function	0	16		1		312	As parameter 2.3.1
P2.3.5	Analogue output function	0	8		1		307	See par. 2.1.5
P2.3.6	Analogue output filter time	0,00	10,00	s	1,00		308	0=No filtering
P2.3.7	Analogue output inversion	0	1		0		309	0=Not inverted 1=Inverted
P2.3.8	Analogue output minimum	0	1		0		310	0=0 mA 1=4 mA
P2.3.9	Analogue output scale	10	1000	%	100		311	
P2.3.10	Expander board analogue output 1 function	0	12		0		472	As parameter P2.1.5
P2.3.11	Expander board analogue output 2 function	0	12		0		479	As parameter P2.1.5
P2.3.12	Output frequency limit 1 supervision	0	2		0		315	0=No limit 1=Low limit supervision 2=High limit supervision
P2.3.13	Output frequency limit 1; Supervised value	0,00	Max. freq	Hz	0,00		316	

Table 1- 8. Output signals, G2.3

3.5 Drive control parameters (Control keypad: Menu P2 → P2.4)

Code	Parameter	Min	Max	Unit	Default	Cust	ID	Note
P2.4.1	Ramp 1 shape	0,0	10,0	s	0,0		500	0=Linear >0=S-curve ramp time
P2.4.2	Brake chopper	0	3		0		504	0=Disabled 1=Used in Run state 3=Used in Run and Stop state
P2.4.3	DC braking current	$0,15 \times I_n$	$1,5 \times I_n$	A	Varies		507	
P2.4.4	DC braking time at stop	0,00	600,00	s	0,00		508	0=DC brake is off at stop
P2.4.5	Frequency to start DC braking during ramp stop	0,10	10,00	Hz	1,50		515	
P2.4.6	DC braking time at start	0,00	600,00	s	0,00		516	0=DC brake is off at start
P2.4.7	Flux brake	0	1		0		520	0=Off 1=On
P2.4.8	Flux braking current	0,0	Varies	A	0,0		519	

Table 1- 9. Drive control parameters, P2.4

3.6 Prohibit frequency parameters (Control keypad: Menu P2 → P2.5)

Code	Parameter	Min	Max	Unit	Default	Cust	ID	Note
P2.5.1	Prohibit frequency range 1 low limit	0,0	Par. 2.5.2	Hz	0,0		509	0=Not used
P2.5.2	Prohibit frequency range 1 high limit	0,0	Max. freq	Hz	0,0		510	0=Not used
P2.5.3	Prohibit frequencies acc./dec. ramp scaling	0,1	10,0	Times	1,0		518	Multiplier of the currently selected ramp time between prohibit frequency limits

Table 1- 10. Prohibit frequency parameters, P2.5

3.7 Motor control parameters (Control keypad: Menu P2 → P2.6)

Code	Parameter	Min	Max	Unit	Default	Cust	ID	Note
P2.6.1	Motor control mode	0	1		0		600	0=Frequency control 1=Speed control
P2.6.2	Switching frequency	1,0	16,0	kHz	6,0		601	Depends on kW
P2.6.3	Overvoltage controller	0	1		1		607	0=Not used 1=Used
P2.6.4	Undervoltage controller	0	1		1		608	0=Not used 1=Used

Table 1- 11. Motor control parameters, P2.6

3.8 Protections (Control keypad: Menu P2 → P2.7)

Code	Parameter	Min	Max	Unit	Default	Cust	ID	Note
P2.7.1	Response to 4mA reference fault	0	3		0		700	0=No response 1=Warning 2=Fault, stop acc. to stop mode 3=Fault, stop by coasting
P2.7.2	Response to external fault	0	3		2		701	0=No response 1=Warning 2= Fault, stop acc. to stop mode 3=Fault, stop by coasting
P2.7.3	Response to undervoltage fault	1	3		2		727	
P2.7.4	Output phase supervision	0	3		2		702	
P2.7.5	Earth fault protection	0	3		2		703	
P2.7.6	Thermal protection of the motor	0	3		2		704	
P2.7.7	Motor ambient temperature factor	-100,0	100,0	%	0,0		705	
P2.7.8	Motor cooling factor at zero speed	0,0	150,0	%	40,0		706	
P2.7.9	Motor thermal time constant	1	200	min	45		707	
P2.7.10	Motor duty cycle	0	100	%	100		708	
P2.7.11	Stall protection	0	3		1		709	As par. 2.7.1
P2.7.12	Stall current limit	0,1	$I_{n\text{motor}} \times 2$	A	$I_{n\text{motor}} \times 1.3$		710	
P2.7.13	Stall time limit	1,00	120,00	s	15,00		711	
P2.7.14	Stall frequency limit	1,0	Max. freq	Hz	25,0		712	
P2.7.15	Underload protection	0	3		0		713	As par. 2.7.1
P2.7.16	Underload curve at nominal frequency	10,0	150,0	%	50,0		714	
P2.7.17	Underload curve at zero frequency	5,0	150,0	%	10,0		715	
P2.7.18	Underload protection time limit	2,00	600,00	s	20,00		716	
P2.7.19	Response to thermistor fault	0	3		0		732	As par. 2.7.1
P2.7.20	Response to fieldbus fault	0	3		2		733	As par. 2.7.1
P2.7.21	Response to slot fault	0	3		2		734	As par. 2.7.1

Table 1- 12. Protections, P2.7

3.9 Autorestart parameters (Control keypad: Menu P2 → P2.8)

Code	Parameter	Min	Max	Unit	Default	Cust	ID	Note
P2.8.1	Wait time	0,10	10,00	s	0,50		717	
P2.8.2	Trial time	0,00	60,00	s	30,00		718	
P2.8.3	Start function	0	2		0		719	0=Ramp 1=Flying start 2=According to par. 2.4.6

Table 1- 13. Auto-restart parameters, P2.8

3.10 Keypad control (Control keypad: Menu K3)

The parameters for the selection of control place and direction on the keypad are listed below. See the Keypad control menu in the Vacon NXL User's Manual.

Code	Parameter	Min	Max	Unit	Default	Cust	ID	Note
P3.1	Control place	1	3		1		125	1 = I/O terminal 2 = Keypad 3 = Fieldbus
R3.2	Keypad reference	Min. freq	Max. freq	Hz				
P3.3	Direction (on keypad)	0	1		0		123	0 = Forward 1 = Reverse
P3.4	Stop button	0	1		1		114	0=Limited function of Stop button 1=Stop button always enabled

Table 1- 14. Keypad control parameters, M3

3.11 System menu (Control keypad: Menu S6)

For parameters and functions related to the general use of the frequency converter, such as customised parameter sets or information about the hardware and software, see Chapter 7.3.6 in the Vacon NXL User's Manual.

3.12 Expander boards (Control keypad: Menu E7)

The E7 menu shows the expander boards attached to the control board and board-related information. For more information, see Chapter 7.3.7 in the Vacon NXL User's Manual.

4. Description of parameters

4.1 BASIC PARAMETERS

2.1.1.1, 2.1.2.1, 2.1.1.2, 2.1.2.2 Minimum/maximum frequency

Defines the frequency limits of the frequency converter.
The maximum value for these parameters is 320 Hz.

2.1.1.3, 2.1.2.3, 2.1.1.4, 2.1.2.4 Acceleration time 1, deceleration time 1

These limits correspond to the time required for the output frequency to accelerate from the zero frequency to the set maximum frequency.

2.1.1.5, 2.1.2.5 Current limit

This parameter determines the maximum motor current from the frequency converter. To avoid motor overload, set this parameter according to the rated current of the motor. The current limit is equal to the rated converter current (I_L) by default.

2.1.1.6, 2.1.2.6 Nominal voltage of the motor

Find this value U_n on the rating plate of the motor. This parameter sets the voltage at the field weakening point to $100\% \times U_{n\text{motor}}$.

2.1.1.7, 2.1.2.7 Nominal frequency of the motor

Find this value f_n on the rating plate of the motor. This parameter sets the field weakening point to the same value.

2.1.1.8, 2.1.2.8 Nominal speed of the motor

Find this value n_n on the rating plate of the motor.

2.1.1.9, 2.1.2.9 Nominal current of the motor

Find this value I_n on the rating plate of the motor.

2.1.1.10, 2.1.2.10 Motor cos phi

Find this value "cos phi" on the rating plate of the motor.

2.1.1.11, 2.1.2.11 Start function

Ramp:

0 The frequency converter starts from 0 Hz and accelerates to maximum frequency within the set acceleration time. (Load inertia or starting friction may cause prolonged acceleration times).

Flying start:

1 The frequency converter is able to start into a running motor by applying a small torque to motor and searching for the frequency corresponding to the speed the motor is running at. The searching starts from the maximum frequency towards the actual frequency until the correct value is detected.

Thereafter, the output frequency will be increased/decreased to the set reference value according to the set acceleration/deceleration parameters.

Use this mode if the motor is coasting when the start command is given. With the flying start, it is possible to ride through short mains voltage interruptions.

2.1.1.12, 2.1.2.12 *Stop function*

Coasting:

0 The motor coasts to a halt without control from the frequency converter after the Stop command.

Ramp:

1 After the Stop command, the speed of the motor is decelerated according to the set deceleration parameters.
If the regenerated energy is high it may be necessary to use an external braking resistor for faster deceleration.

2.1.1.13, 2.1.2.13 *U/f optimisation*

0 Not used

1 **Automatic torque boost**
The voltage to the motor changes automatically, which makes the motor produce sufficient torque to start and run at low frequencies. The voltage increase depends on the motor type and power. Automatic torque boost can be used in applications where starting torque due to starting friction is high, e.g. in conveyors.

NOTE! *In high torque – low speed applications – it is likely that the motor will overheat. If the motor has to run a prolonged time under these conditions, special attention must be paid to cooling the motor. Use external cooling for the motor if the temperature tends to rise too high.*

2.1.1.14, 2.1.2.14 *U/f ratio selection*

Linear: The voltage of the motor changes linearly with the frequency in the constant flux area from 0 Hz to the field weakening point where the nominal voltage is supplied to the motor. Linear U/f ratio should be used in constant torque applications.
0 **This default setting should be used if there is no special need for another setting.**

Squared: The voltage of the motor changes following a squared curve form with the frequency in the area from 0 Hz to the field weakening point where the nominal voltage is also supplied to the motor. The motor runs under magnetised below the field weakening point and produces less torque and electromechanical noise. Squared U/f ratio can be used in applications where torque demand of the load is proportional to the square of the speed, e.g in centrifugal fans and pumps.
1

Programmable U/f curve:

- 2 The U/f curve can be programmed with three different points. Programmable U/f curve can be used if the other settings do not satisfy the needs of the application.

Linear with flux optimisation:

- 3 The frequency converter starts to search for the minimum motor current and in order to save energy, lower the disturbance level and the noise. Can be used in applications with constant motor load, such as fans, pumps etc.

2.1.1.15, 2.1.2.15 U/f curve, middle point frequency

If the programmable U/f curve has been selected, this parameter defines the middle point frequency of the curve.

2.1.1.16, 2.1.2.16 U/f curve, middle point voltage

If the programmable U/f curve has been selected, this parameter defines the middle point voltage of the curve.

2.1.1.17, 2.1.2.17 Output voltage at zero frequency

This parameter defines the zero frequency voltage of the curve.

2.1.1.18, 2.1.2.18 Field weakening point

The field weakening point is the output frequency at which the output voltage reaches the value set with parameter 2.1.1.19/2.1.2.19.

2.1.1.19, 2.1.2.19 Voltage at field weakening point

Above the frequency at the field weakening point, the output voltage remains at the value set with this parameter. Below the frequency at the field weakening point, the output voltage depends on the setting of the U/f curve parameters.

When the motor nominal voltage and nominal frequency are set, the FWP and voltage at FWP are automatically given the corresponding values. If you need different values for the field weakening point and the voltage, change these parameters **after** setting the nominal voltage and frequency parameters.

2.1.3 I/O Reference selection

Defines the selected frequency reference source when the drive is controlled from the I/O terminal.

- 0 AI1 reference (terminals 2 and 3, e.g. potentiometer)
- 1 AI2 reference (terminals 5 and 6, e.g. transducer)
- 2 Keypad reference (parameter 3.2)
- 3 Reference from Fieldbus (FBSpeedReference)

2.1.4 *AI2 (I_m) signal range*

- 1 Signal range 0...20 mA
- 2 Signal range 4...20 mA
- 3 Signal range 0...10V
- 4 Signal range 2...10V

Note! The selections have no effect if par. 2.2.13 > 0%, or par. 2.2.14 < 100%.

2.1.5 *Analogue output function*

This parameter selects the desired function for the analogue output signal. See the table on page 7 for the parameter values.

2.1.6 *DIN2 function*

This parameter has 7 selections. If digital input DIN2 need not be used, set the parameter value to 0.

- 1 Start reverse
- 2 Reverse
- 3 Stop pulse
- 4 External fault
Contact closed: Fault is displayed and motor stopped when the input is active
- 5 External fault
Contact open: Fault is displayed and motor stopped when the input is not active
- 6 Run enable
Contact open: Start of motor disabled
Contact closed: Start of motor enabled
Coast stop if dropped during RUN
- 7 Preset speed 2

2.1.7 *DIN3 function*

This parameter has 9 selections. If digital input DIN3 need not be used, set the param. value to 0.

- 1 Reverse
Contact open: Forward
Contact closed: Reverse
- 2 External fault
Contact closed: Fault is displayed and motor stopped when the input is active
- 3 External fault
Contact open: Fault is displayed and motor stopped when the input is not active
- 4 Fault reset
Contact closed: All faults reset
- 5 Run enable
Contact open: Start of motor disabled
Contact closed: Start of motor enabled
Coast stop if dropped during RUN

- 6 Preset speed 1
- 7 Preset speed 2
- 8 DC braking command
Contact closed: In Stop mode, the DC braking operates until the contact is opened.
DC-braking current is about 10% of the value selected with [par. 2.4.3](#).
- 9 Parameter set selection
Contact open: Parameter set 1 is active (Parameter group G2.1.1)
Contact close: Parameter set 2 is active (Parameter group G2.1.2)

2.1.8 *Preset speed 1*

2.1.9 *Preset speed 2*

Parameter values are automatically limited between the minimum and maximum frequencies.

2.1.10 *Automatic restart function*

The automatic restart is taken into use with this parameter

0 = Disabled

1 = Enabled (3 automatic restarts, see [par. 2.8.1 – 2.8.3](#))

2.1.11 *Parameter conceal*

With this parameter you can hide all other parameter groups except the basic parameter group (P2.1).

Note! The factory default of this parameter is **1**, i.e. all parameter groups except P2.1 have been hidden. The other parameter groups cannot be browsed or edited before the value of this parameter is set to **0**.

0 = Disabled (all parameter groups can be browsed with the keypad)

1 = Enabled (only the basic parameters, P2.1, can be browsed with the keypad)

4.2 INPUT SIGNALS

2.2.1 Expander board DIE1 function

This parameter has 9 selections. If the expander board digital input DIN1 need not be used, set the parameter value to 0.

Selections are as in parameter 2.1.7

2.2.2 Expander board DIE2 function

The selections are the same as in parameter 2.1.7

2.2.3 Expander board DIE3 function

The selections are the same as in parameter 2.1.7.

2.2.4 DIN4 Function

If the value of [par. 2.2.6](#) is set to 0, All functions as digital input 4. The selections are the same as in parameter 2.1.7.

NOTE! If you program the analogue input as DIN4 check that the jumper selections are correct (see figure below)

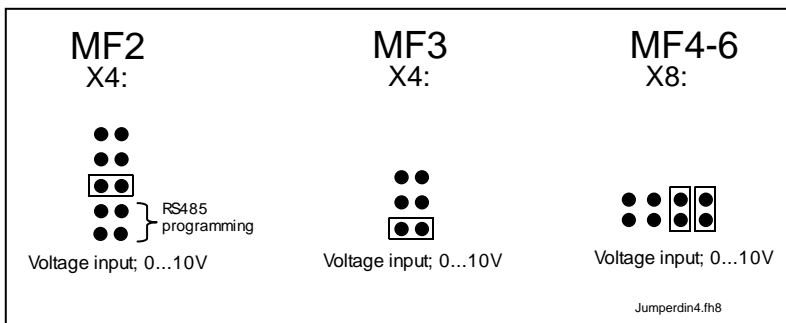

2.2.5 All signal selection

Connect the All signal to the analogue input of your choice with this parameter.

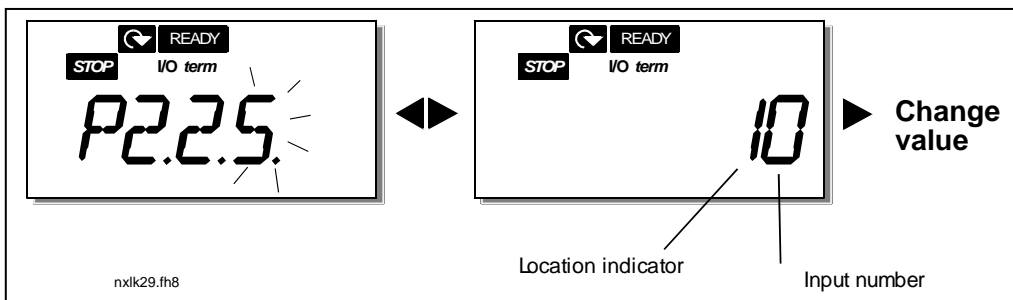

The value of this parameter is formed of the board indicator and the respective input terminal number. See figure above.

Board indicator 1 = Local inputs
Board indicator 2 = Expander board inputs

Input number 0 = Input 1
Input number 1 = Input 2
Input number 2 = Input 3
⋮
Input number 9 = Input 10

Example:

If you set the value of this parameter to **10**, you have selected the local input 1 for the AI1 signal. Again, if the value is set to **21**, the expander board input 2 has been selected for the AI1 signal.

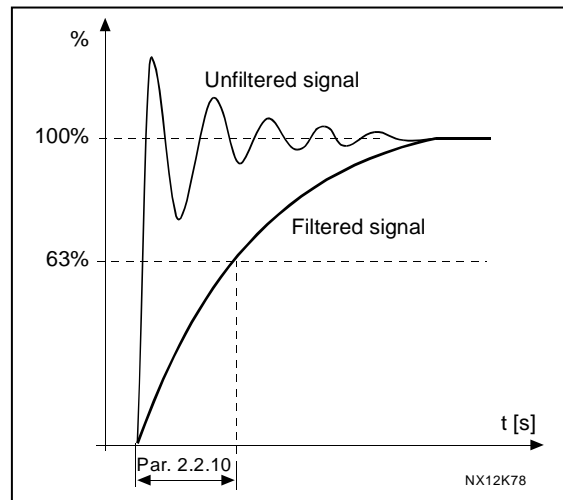

If you want to use the values of analogue input signal for e.g. testing purposes only, you can set the parameter value to **0 - 9**. In this case, value **0** corresponds to **0%**, value **1** corresponds to **20%** and any value between **2** and **9** corresponds to **100%**.

2.2.6 AI1 signal range

With this parameter you can select the AI1 signal range.

0 = DIN 4
1 = Signal range 0...20mA (only for sizes MF4 and bigger)
2 = Signal range 4...20mA (only for sizes MF4 and bigger)
3 = Signal range 0...10V
4 = Signal range 2...10V

Note! The selections have no effect if par. 2.2.7 > 0%, or par. 2.2.8 < 100%.

If the value of par. 2.2.6 is set to **0**, AI1 functions as digital input 4.
See par. 2.2.4

2.2.7 AI1 custom setting minimum

2.2.8 AI1 custom setting maximum

Set the custom minimum and maximum levels for the AI1 signal within 0...10V.

2.2.9 AI1 signal inversion

By setting the parameter value to **1** the AI1 signal inversion takes place.

2.2.10 AI1 signal filter time

This parameter, given a value greater than 0, activates the function that filters out disturbances from the incoming analogue U_{in} signal.
Long filtering time makes the regulation response slower.

2.2.11 *AI2 signal selection*

Connect the AI2 signal to the analogue input of your choice with this parameter. See [par. 2.2.5](#) for the value setting procedure.

2.2.12 *AI2 signal range*

- 1 = Signal range 0...20mA
- 2 = Signal range 4...20mA
- 3 = Signal range 0...10V
- 4 = Signal range 2...10V

Note! The selections have no effect if par. 2.2.13 > 0%, or par.2.2.14 < 100%.

2.2.13 *AI2 custom minimum*

2.2.14 *AI2 custom maximum*

These parameters allow you to scale the input current signal between 0 and 20 mA.

2.2.15 *Analogue input AI2 signal inversion*

By setting the parameter value to 1 the AI2 signal inversion takes place.

2.2.16 *Analogue input AI2 signal filter time*

See corresponding parameter [2.2.10](#).

2.2.17 *Reference scaling minimum value*

2.2.18 *Reference scaling maximum value*

You can choose a scaling range for the frequency reference between the [Minimum](#) and [Maximum](#) frequency. If no scaling is desired set the parameter value to 0.
In the figures below, voltage input AI1 with signal range 0...10V is selected for reference.

2.2.19 *Keypad frequency reference selection*

Defines the selected reference source when the drive is controlled from the keypad

- 0 AI1 reference (by default AI1, terminals 2 and 3, e.g. potentiometer)
- 1 AI2 reference (by default AI2, terminals 5 and 6, e.g. transducer)
- 2 Keypad reference (parameter 3.2)
- 3 Reference from Fieldbus (FBSpeedReference)

2.2.20 *Fieldbus frequency reference selection*

Defines the selected reference source when the drive is controlled from the fieldbus.
Same selections as 2.2.19 above.

4.3 OUTPUT SIGNALS

- 2.3.1 *Relay output 1 function*
- 2.3.2 *Expander board relay output 1 function*
- 2.3.3 *Expander board relay output 2 function*
- 2.3.4 *Expander board digital output 1 function*

Setting value	Signal content
0 = Not used	Out of operation
	<u>Relay output R01 and expander board programmable relays (R01, R02) are activated when:</u>
1 = Ready	The frequency converter is ready to operate
2 = Run	The frequency converter operates (motor is running)
3 = Fault	A fault trip has occurred
4 = Fault inverted	A fault trip <u>not</u> occurred
5 = Frequency converter overheat warning	The heat-sink temperature exceeds +70°C
6 = External fault or warning	Fault or warning depending on par. 2.7.2
7 = Reference fault or warning	Fault or warning depending on par. 2.7.1 - if analogue reference is 4–20 mA and signal is <4mA
8 = Warning	Always if a warning exists
9 = Reversed	The reverse command has been selected
10 = Preset speed	A preset speed has been selected
11 = At speed	The output frequency has reached the set reference
12 = Motor regulator activated	Overvoltage or overcurrent regulator was activated
13 = Output frequency limit 1 supervision	The output frequency goes outside the set supervision low limit/high limit (see parameters 2.3.12 and 2.3.13 below)
14 = Control from I/O terminals	Selected control place (Menu K3 ; par. 3.1) is "I/O terminal"
15 = Thermistor fault or warning	The thermistor input of option board indicates overtemperature. Fault or warning depending on parameter 2.7.19 .
16 = Active parameter set indication	Open contactor=Set 1, closed contactor=Set2

Table 1- 15. Output signals via R01 and expander board R01, R02 and DO1.

2.3.5 *Analogue output function*

This parameter selects the desired function for the analogue output signal. See the table on page 7 for the parameter values.

2.3.6 Analogue output filter time

Defines the filtering time of the analogue output signal.
 If you set value **0** for this parameter, no filtering takes place.

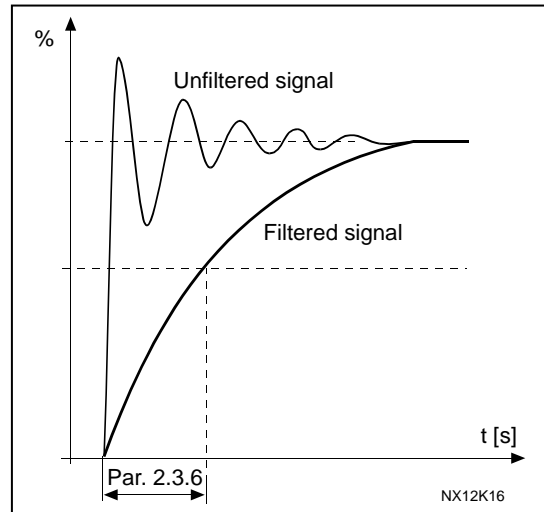

2.3.7 Analogue output invert

Inverts the analogue output signal:

Maximum output signal = 0 %
 Minimum output signal = Maximum set value (parameter 2.3.9)

- 0 Not inverted
- 1 Inverted

See parameter 2.3.9 below.

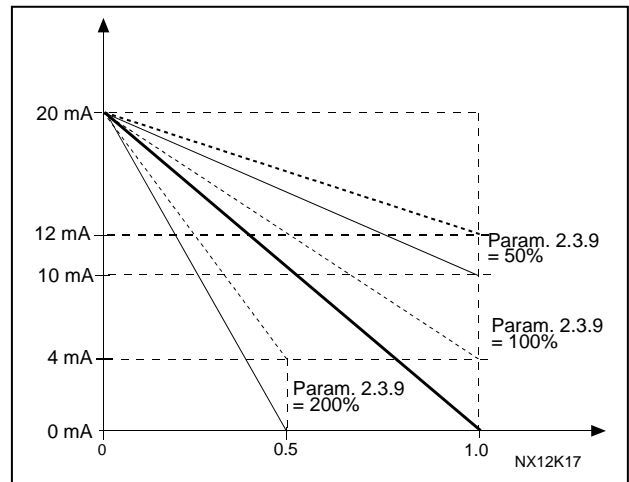

2.3.8 Analogue output minimum

Sets the signal minimum to either 0 mA or 4 mA (living zero). Note the difference in the analogue output scaling in parameter 2.3.9.

2.3.9 Analogue output scale

Scaling factor for the analogue output.

Signal	Max. value of the signal
Output frequency	100% x f_{max}
Motor speed	100% x Motor nom. speed
Output current	100% x I_{nMotor}
Motor torque	100% x T_{nMotor}
Motor power	100% x P_{nMotor}
Motor voltage	100% x U_{nMotor}
DC-link voltage	1000 V

Table 1- 16. Analogue output scaling

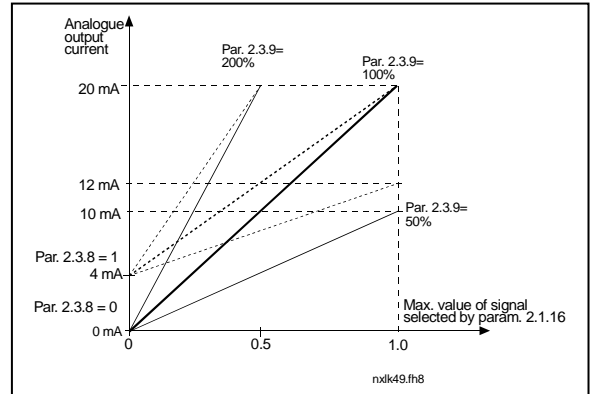

2.3.10 Expander board analogue output 1 function

2.3.11 Expander board analogue output 2 function

These parameters select the desired functions for the expander board analogue output signals. See par 2.1.5 for the parameter values.

2.3.12 Output frequency limit 1 supervision function

- 0 No supervision
- 1 Low limit supervision
- 2 High limit supervision

If the output frequency goes under/over the set limit (par. 2.3.13) this function generates a warning message via the relay outputs depending on the settings of parameters 2.3.1 – 2.3.4.

2.3.13 Output frequency limit 1 supervised value

Selects the frequency value supervised by parameter 2.3.12.

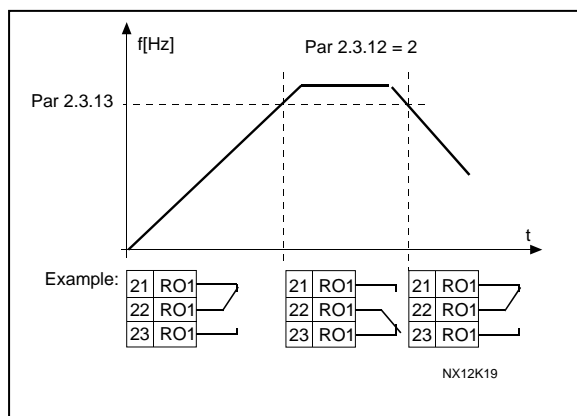

4.4 DRIVE CONTROL

2.4.1 *Acceleration/Deceleration ramp 1 shape*

The start and end of the acceleration and deceleration ramp can be smoothed with this parameter. Setting value 0 gives a linear ramp shape, which causes acceleration and deceleration to act immediately to the changes in the reference signal. Setting value 0.1...10 seconds for this parameter produces an S-shaped acceleration/deceleration.

2.4.2 *Brake chopper*

Note! An internal brake chopper is installed in all other sizes but MF2

- 0 No brake chopper used
- 1 Brake chopper used in Run state
- 3 Used in Run and Stop state

When the frequency converter is decelerating the motor, the inertia of the motor and the load are fed into an external brake resistor. This enables the frequency converter to decelerate the load with a torque equal to that of acceleration (provided that the correct brake resistor has been selected). See separate Brake resistor installation manual.

2.4.3 *DC-braking current*

Defines the current injected into the motor during DC-braking.

2.4.4 *DC-braking time at stop*

Determines if braking is ON or OFF and the braking time of the DC-brake when the motor is stopping. The function of the DC-brake depends on the stop function.

- 0 DC-brake is not used
- >0 DC-brake is in use and its function depends on the Stop function. The DC-braking time is determined with this parameter

Stop function = Coasting:

After the stop command, the motor coasts to a stop without control from the frequency converter.

With the DC injection, the motor can be electrically stopped in the shortest possible time, without using an optional external braking resistor.

The braking time is scaled by the frequency when the DC-braking starts. If the frequency is greater than the nominal frequency of the motor, the set value of parameter 2.4.4 determines the braking time. When the frequency is $\leq 10\%$ of the nominal, the braking time is 10% of the set value of parameter 2.4.4.

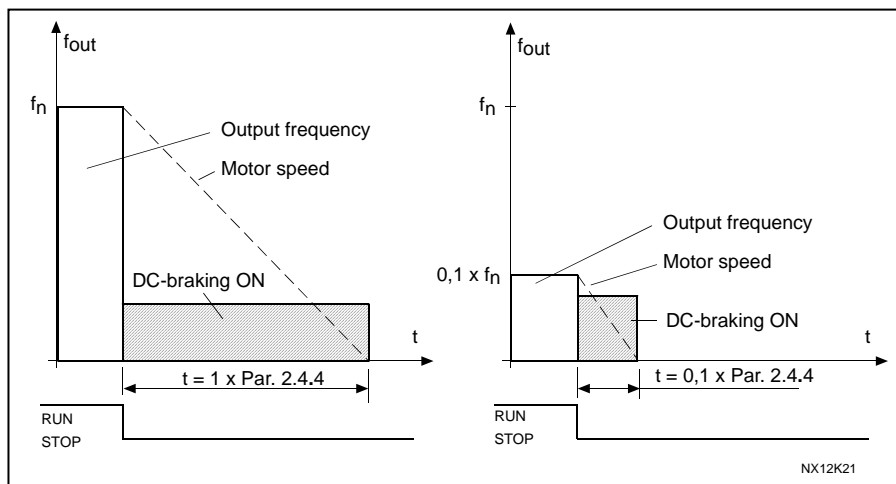

Stop function = Ramp:

After the Stop command, the speed of the motor is reduced according to the set deceleration parameters, as fast as possible, to the speed defined with parameter 2.4.5, where the DC-braking starts.

The braking time is defined with parameter 2.4.4. If high inertia exists, it is recommended to use an external braking resistor for faster deceleration.

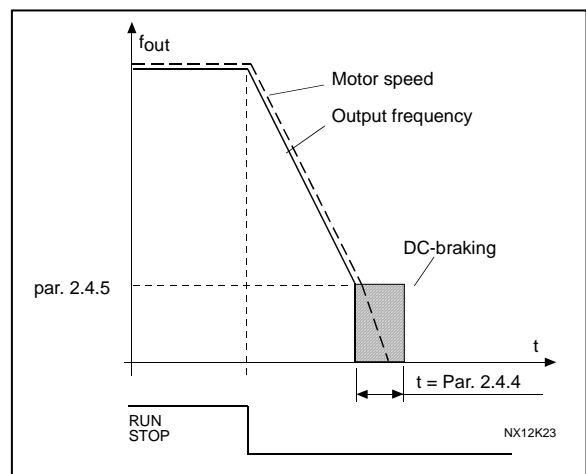

2.4.5 DC-braking frequency in ramp stop

The output frequency at which the DC-braking is applied.

2.4.6 *DC-braking time at start*

DC-brake is activated when the start command is given. This parameter defines the time before the brake is released. After the brake is released, the output frequency increases according to the set start function.

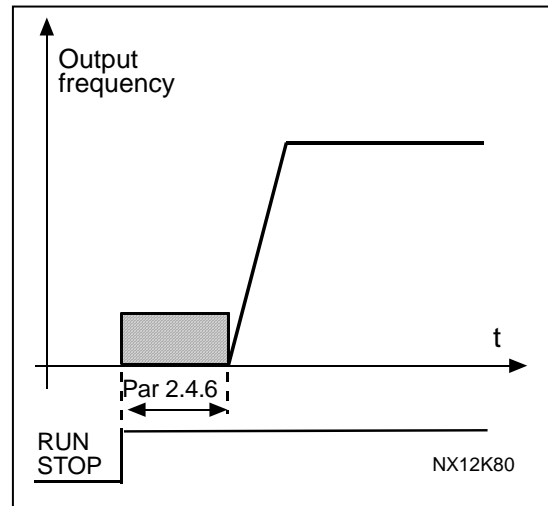

2.4.7 *Flux brake*

The flux braking can be set ON or OFF.

0 = Flux braking OFF

1 = Flux braking ON

2.4.8 *Flux braking current*

Defines the flux braking current value. It can be set between $0.3 \times I_H$ (approximately) and the [Current limit](#).

4.5 PROHIBIT FREQUENCIES

- 2.5.1 *Prohibit frequency area 1; Low limit*
- 2.5.2 *Prohibit frequency area 1; High limit*

In some systems it may be necessary to avoid certain frequencies because of mechanical resonance problems. With these parameters it is possible to set a limit for the "skip frequency" region.

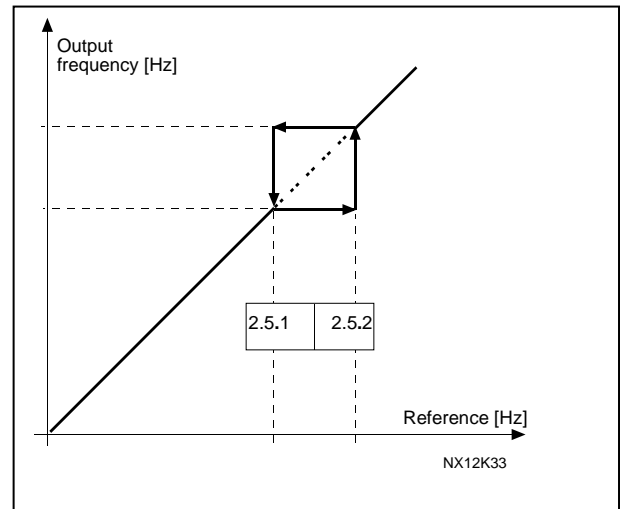

- 2.5.3 *Acceleration/deceleration ramp speed scaling ratio between prohibit frequency limits*

Defines the acceleration/deceleration time when the output frequency is between the selected prohibit frequency range limits (parameters 2.5.1 and 2.5.2). The ramping time (selected acceleration/ deceleration time 1 or 2) is multiplied with this factor. E.g. value 0.1 makes the acceleration time 10 times shorter than outside the prohibit frequency range limits.

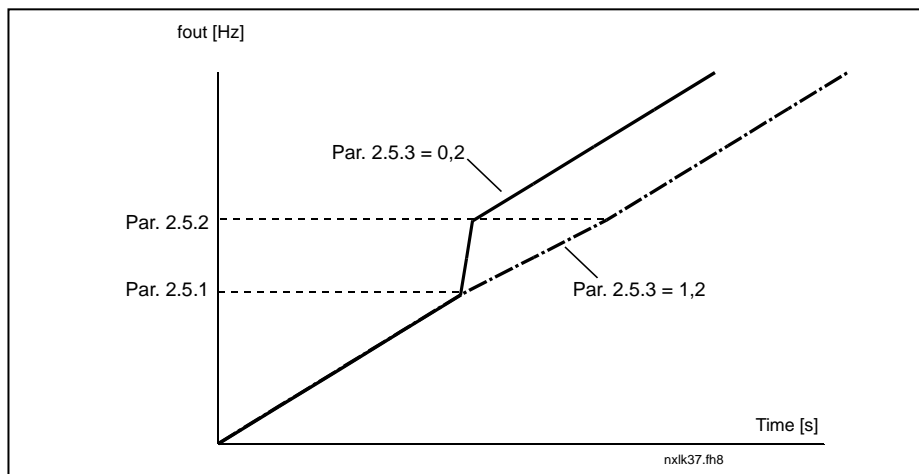

4.6 MOTOR CONTROL

2.6.1 *Motor control mode*

- | | | |
|---|--------------------|---|
| 0 | Frequency control: | The I/O terminal and keypad references are frequency references and the frequency converter controls the output frequency (output frequency resolution = 0.01 Hz) |
| 1 | Speed control: | The I/O terminal and keypad references are speed references and the frequency converter controls the motor speed (accuracy $\pm 0,5\%$). |

2.6.2 *Switching frequency*

Motor noise can be minimised using a high switching frequency. Increasing the switching frequency reduces the capacity of the frequency converter unit.

Switching frequency for Vacon NXL: 1...16 kHz

2.6.3 *Overvoltage controller*

2.6.4 *Undervoltage controller*

These parameters allow the under-/overvoltage controllers to be switched out of operation. This may be useful, for example, if the mains supply voltage varies more than -15% to $+10\%$ and the application will not tolerate this over-/undervoltage. This regulator controls the output frequency taking the supply fluctuations into account.

Note: Over-/undervoltage trips may occur when controllers are switched out of operation.

- | | |
|---|-------------------------|
| 0 | Controller switched off |
| 1 | Controller switched on |

4.7 PROTECTIONS

2.7.1 *Response to 4mA reference fault*

- 0 = No response
- 1 = Warning
- 2 = Fault, stop mode after fault according to stop function parameter
- 3 = Fault, stop mode after fault always by coasting

A warning or a fault action and message is generated if the 4...20 mA reference signal is used and the signal falls below 3.5 mA for 5 seconds or below 0.5 mA for 0.5 seconds. The information can also be programmed into relay outputs.

2.7.2 *Response to external fault*

- 0 = No response
- 1 = Warning
- 2 = Fault, stop mode after fault according to stop function parameter
- 3 = Fault, stop mode after fault always by coasting

A warning or a fault action and message is generated from the external fault signal in the programmable digital inputs. The information can also be programmed into relay outputs.

2.7.3 *Response to undervoltage fault*

- 1 = Warning
- 2 = Fault, stop mode after fault according to stop function parameter
- 3 = Fault, stop mode after fault always by coasting

For the undervoltage limits see Vacon NXL, User's Manual, Table 4-3.
Note: This protection can not be inactivated.

2.7.4 *Output phase supervision*

- 0 = No response
- 1 = Warning
- 2 = Fault, stop mode after fault according to stop function parameter
- 3 = Fault, stop mode after fault always by coasting

Output phase supervision of the motor ensures that the motor phases have an approximately equal current.

2.7.5 *Earth fault protection*

- 0 = No response
- 1 = Warning
- 2 = Fault, stop mode after fault according to stop function parameter
- 3 = Fault, stop mode after fault always by coasting

Earth fault protection ensures that the sum of the motor phase currents is zero. The overcurrent protection is always working and protects the frequency converter from earth faults with high currents.

Parameters 2.7.6—2.7.10, Motor thermal protection:**General**

The motor thermal protection is to protect the motor from overheating. The Vacon drive is capable of supplying higher than nominal current to the motor. If the load requires this high current there is a risk that the motor will be thermally overloaded. This is the case especially at low frequencies. At low frequencies the cooling effect of the motor is reduced as well as its capacity. If the motor is equipped with an external fan the load reduction at low speeds is small.

The motor thermal protection is based on a calculated model and it uses the output current of the drive to determine the load on the motor.

The motor thermal protection can be adjusted with parameters. The thermal current I_T specifies the load current above which the motor is overloaded. This current limit is a function of the output frequency.

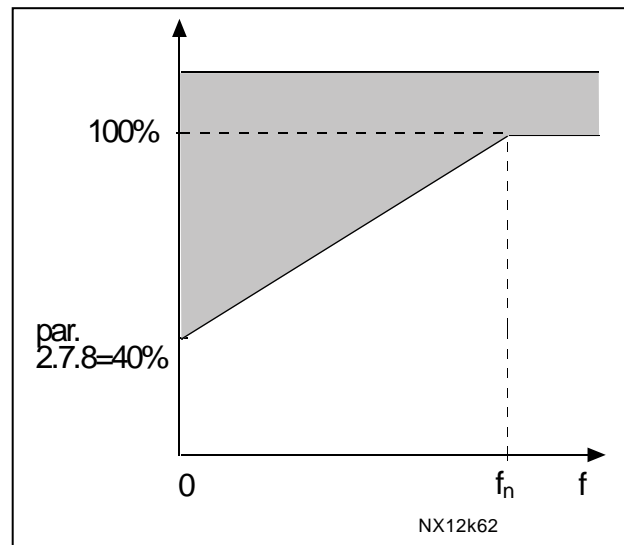

	<p>CAUTION! The calculated model does not protect the motor if the airflow to the motor is reduced by blocked air intake grill.</p>
---	--

2.7.6 Motor thermal protection

- 0 = No response
- 1 = Warning
- 2 = Fault, stop mode after fault according to stop function parameter
- 3 = Fault, stop mode after fault always by coasting

If tripping is selected the drive will stop and activate the fault stage.

Deactivating the protection, i.e. setting parameter to 0, will reset the thermal model of the motor to 0%.

2.7.7 Motor thermal protection: Motor ambient temperature factor

When the motor ambient temperature must be taken into consideration, it is recommended to set a value for this parameter. The value of the factor can be set between -100.0% and 100.0% where -100.0% corresponds to 0°C and 100.0% to the maximum running ambient temperature of the motor. Setting this parameter value to 0% assumes that the ambient temperature is the same as the temperature of the heatsink at power-on.

2.7.8 Motor thermal protection: Cooling factor at zero speed

The cooling power can be set between 0—150.0% x cooling power at nominal frequency.

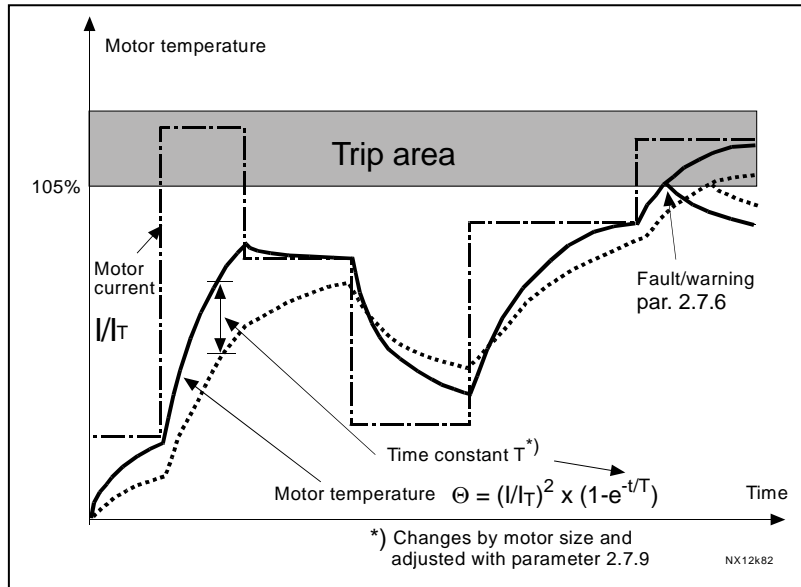

2.7.9 Motor thermal protection: Time constant

This time can be set between 1 and 200 minutes.

This is the thermal time constant of the motor. The bigger the motor, the bigger the time constant. The time constant is the time within which the calculated thermal model has reached 63% of its final value.

The motor thermal time is specific to the motor design and it varies between different motor manufacturers.

If the motor's t_6 -time (t_6 is the time in seconds the motor can safely operate at six times the rated current) is known (given by the motor manufacturer) the time constant parameter can be set basing on it. As a rule of thumb, the motor thermal time constant in minutes equals to $2 \times t_6$. If the drive is in stop state the time constant is internally increased to three times the set parameter value. The cooling in the stop state is based on convection and the time constant is increased. See also .

Note: If the nominal speed or the nominal current of the motor are changed this parameter is automatically set to the default value (45).

2.7.10 Motor thermal protection: Motor duty cycle

Defines how much of the nominal motor load is applied. The value can be set to 0%...100%.

Parameter 2.7.11, Stall protection:

General

The motor stall protection protects the motor from short time overload situations such as one caused by a stalled shaft. The reaction time of the stall protection can be set shorter than that of motor thermal protection. The stall state is defined with two parameters, 2.7.12 (Stall current) and 2.7.13 (Stall frequency). If the current is higher than the set limit and output frequency is lower than the set limit, the stall state is true. There is actually no real indication of the shaft rotation. Stall protection is a type of overcurrent protection.

2.7.11 Stall protection

- 0 = No response
- 1 = Warning
- 2 = Fault, stop mode after fault according to stop function parameter
- 3 = Fault, stop mode after fault always by coasting

Setting the parameter to 0 will deactivate the protection and reset the stall time counter.

2.7.12 Stall current limit

The current can be set to $0.0 \dots I_{nMotor} * 2$. For a stall stage to occur, the current must have exceeded this limit. See Figure 1-20. The software does not allow entering a greater value than $I_{nMotor} * 2$. If the nominal current of motor is changed, this parameter is automatically restored to the default value ($I_{nMotor} * 1.3$).

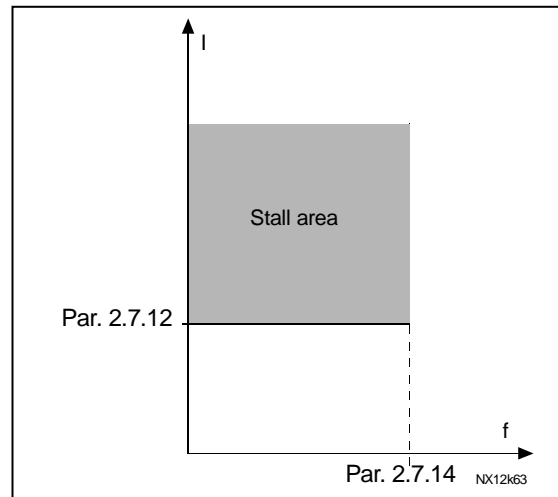

2.7.13 Stall time

This time can be set between 1.0 and 120.0s. This is the maximum time allowed for a stall event detection. The stall time is counted by an internal up/down counter. If the stall time counter value goes above this limit the protection will cause a trip.

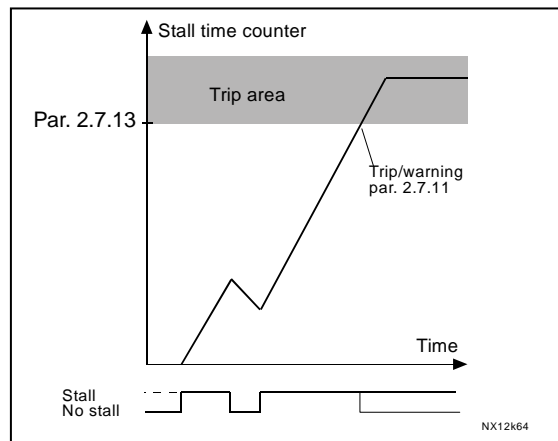

2.7.14 *Maximum stall frequency*

The frequency can be set between $1-f_{\max}$

For a stall event to occur, the output frequency must have remained below this limit.

Parameters 2.7.15—2.7.18, Underload protection:

General

The purpose of the motor underload protection is to ensure that there is load on the motor when the drive is running. If the motor loses its load there might be a problem in the process, e.g. a broken belt or a dry pump.

Motor underload protection can be adjusted by setting the underload curve with parameters 2.7.16 (Field weakening area load) and 2.7.17 (Zero frequency load), see below. The underload curve is a squared curve set between the zero frequency and the field weakening point. The protection is not active below 5Hz (the underload time counter is stopped).

The torque values for setting the underload curve are set in percentage, which refers to the nominal torque of the motor. The motor's name-plate data, the parameter Motor nominal current and the drive's nominal current I_L are used to find the scaling ratio for the internal torque value. If other than nominal motor is used with the drive, the accuracy of the torque calculation decreases.

2.7.15 *Underload protection*

0 = No response

1 = Warning

2 = Fault, stop mode after fault according to stop function parameter

3 = Fault, stop mode after fault always by coasting

If tripping is set active the drive will stop and activate the fault stage. Deactivating the protection by setting the parameter to 0 will reset the underload time counter.

2.7.16 *Underload protection, field weakening area load*

The torque limit can be set between $10.0\text{--}150.0\% \times T_{n\text{Motor}}$

This parameter gives the value for the minimum torque allowed when the output frequency is above the field weakening point. If you change the Motor nominal current, this parameter is automatically restored to the default value.

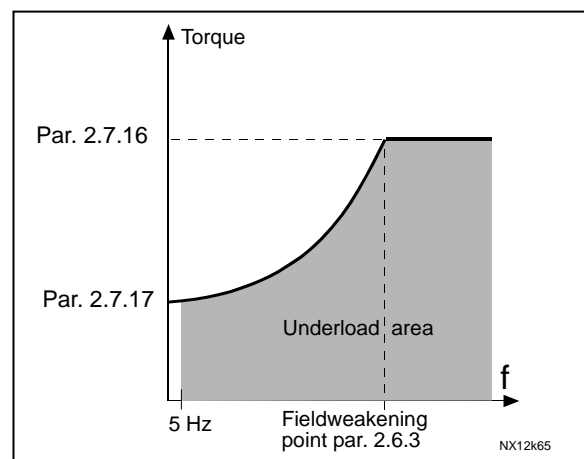

2.7.17 *Underload protection, zero frequency load*

The torque limit can be set between 5.0—150.0 % x T_{nMotor} .

This parameter gives value for the minimum torque allowed with zero frequency.

If you change the value of motor nominal current, this parameter is automatically restored to the default value.

2.7.18 *Underload time*

This time can be set between 2.0 and 600.0 s.

This is the maximum time allowed for an underload state to exist. An internal up/down counter counts the accumulated underload time. If the underload counter value goes above this limit the protection will cause a trip according to parameter 2.7.15). If the drive is stopped the underload counter is reset to zero.

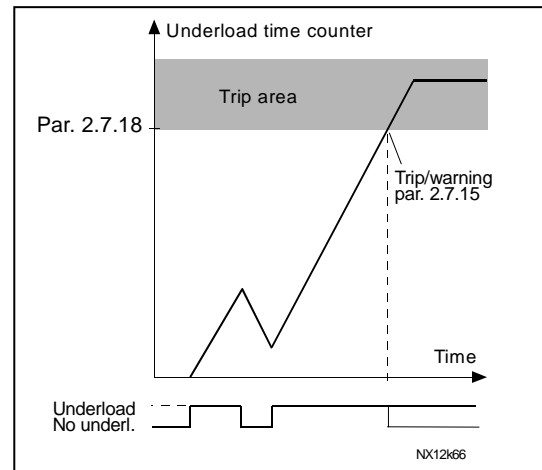

2.7.19 *Response to thermistor fault*

0 = No response

1 = Warning

2 = Fault, stop mode after fault according to stop function parameter

3 = Fault, stop mode after fault always by coasting

Setting the parameter to 0 will deactivate the protection.

2.7.20 *Response to fieldbus fault*

Set here the response mode for the fieldbus fault if a fieldbus board is used. For more information, see the respective Fieldbus Board Manual.

See parameter 2.7.19.

2.7.21 *Response to slot fault*

Set here the response mode for a board slot fault due to missing or broken board.

See parameter 2.7.19.

2.7.22 *Actual value supervision function*

0 = Not used

1 = Warning, if actual value falls below the limit set with par. 2.7.23

2 = Warning, if actual value exceeds the limit set with par. 2.7.23

3 = Fault, if actual value falls below the limit set with par. 2.7.23

4 = Fault, if actual value exceeds the limit set with par. 2.7.23

2.7.23 *Actual value supervision limit*

With this parameter you can set the limit of actual value supervised by par. 2.7.22

2.7.24 *Actual value supervision delay*

Set here the delay for the actual value supervision function (par. 2.7.22)

If this parameter is in use, the function of par. 2.7.22 will be active only when the actual value stays outside the defined limit for the time determined by this parameter.

4.8 AUTO RESTART PARAMETERS

The automatic restart function is active if the value of par. 2.1.10 = 1. There are always three restart trials

2.8.1 Automatic restart: Wait time

Defines the time before the frequency converter tries to automatically restart the motor after the fault has disappeared.

2.8.2 Automatic restart: Trial time

The Automatic restart function restarts the frequency converter when the faults have disappeared and the waiting time has elapsed.

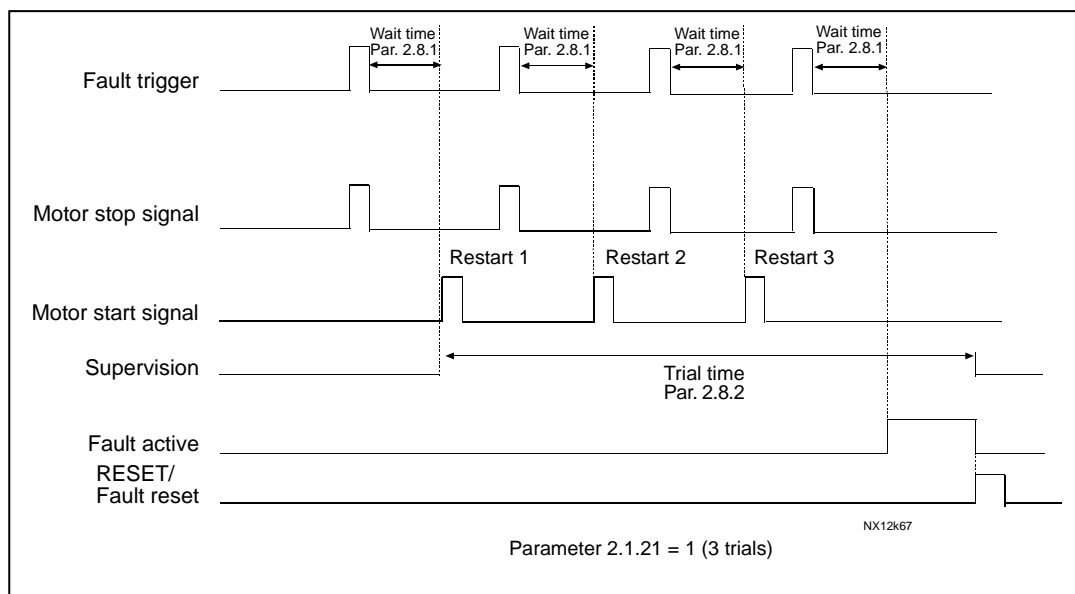

The time count starts from the first autorestart. If the number of faults occurring during the trial time exceeds three, the fault state becomes active. Otherwise the fault is cleared after the trial time has elapsed and the next fault starts the trial time count again.

If a single fault remains during the trial time, a fault state is true.

2.8.3 Automatic restart, start function

The Start function for Automatic restart is selected with this parameter. The parameter defines the start mode:

- 0 = Start with ramp
- 1 = Flying start
- 2 = Start according to start function parameter

4.9 KEYPAD CONTROL PARAMETERS

3.1 *Control place*

The active control place can be changed with this parameter. For more information, see Vacon NXL User's Manual, Chapter 7.3.3.

3.2 *Keypad reference*

The frequency reference can be adjusted from the keypad with this parameter. For more information, see Vacon NXL User's Manual, Chapter 7.3.3.2.

3.3 *Keypad direction*

- 0 Forward: The rotation of the motor is forward, when the keypad is the active control place.
- 1 Reverse: The rotation of the motor is reversed, when the keypad is the active control place.

For more information, see Vacon NXL User's Manual, Chapter 7.3.3.3.

3.4 *Stop button activated*

If you wish to make the Stop button a "hotspot" which always stops the drive regardless of the selected control place, give this parameter the value 1 (default). See Vacon NXL User's Manual, Chapter 7.3.3.

See also parameter 3.1

Vaasa

Vacon Plc (Head office and production)
Runsorintie 7
65380 Vaasa
firstname.lastname@vacon.com
telephone: +358 (0)201 2121
fax: +358 (0)201 212 205

Helsinki

Vacon Plc
Äyritie 12
01510 Vantaa
telephone: +358 (0)201 212 600
fax: +358 (0)201 212 699

Tampere

Vacon Plc
Vehnämyllynkatu 18
33580 Tampere
telephone: +358 (0)201 2121
fax: +358 (0)201 212 750

Vacon Traction Oy

Vehnämyllynkatu 18
33580 Tampere
telephone: +358 (0)201 2121
fax: +358 (0)201 212 710

SALES COMPANIES AND REPRESENTATIVE OFFICES:**Austria**

Vacon AT Antriebssysteme GmbH
Aumühlweg 21
2544 Leobersdorf
telephone: +43 2256 651 66
fax: +43 2256 651 66 66

Belgium

Vacon Benelux NV/SA
Interleuvenlaan 62
3001 Heverlee (Leuven)
telephone: +32 (0)16 394 825
fax: +32 (0)16 394 827

France

Vacon France
ZAC du Fresne
1 Rue Jacquard – BP72
91280 Saint Pierre du Perray CDIS
telephone: +33 (0)1 69 89 60 30
fax: +33 (0)1 69 89 60 40

Germany

Vacon GmbH
Gladbecker Strasse 425
45329 Essen
telephone: +49 (0)201 806 700
fax: +49 (0)201 806 7099

Great Britain

Vacon Drives (UK) Ltd.
18, Maizefield
Hinckley Fields Industrial Estate
Hinckley
LE10 1YF Leicestershire
telephone: +44 (0)1455 611 515
fax: +44 (0)1455 611 517

Italy

Vacon S.p.A.
Via F.lli Guerra, 35
42100 Reggio Emilia
telephone: +39 0522 276811
fax: +39 0522 276890

The Netherlands

Vacon Benelux BV
Weide 40
4206 CJ Gorinchem
telephone: +31 (0)183 642 970
fax: +31 (0)183 642 971

Norway

Vacon AS
Langgata 2
3080 Holmestrand
telephone: +47 330 96120
fax: +47 330 96130

PR China

Vacon Suzhou Drives Co. Ltd.
Building 13CD
428 Xinglong Street
Suchun Industrial Square
Suzhou 215126
telephone: +86 512 6283 6630
fax: +86 512 6283 6618

Vacon Suzhou Drives Co. Ltd.

Beijing Office
A205, Grand Pacific Garden Mansion
8A Guanhua Road
Beijing 100026
telephone: +86 10 6581 3734
fax: +86 10 6581 3754

Russia

ZAO Vacon Drives
Bolshaja Jakimanka 31,
stroenie 18
109180 Moscow
telephone: +7 (095) 974 14 47
fax: +7 (095) 974 15 54

ZAO Vacon Drives
2ya Sovetskaya 7, office 210A
191036 St. Petersburg
telephone: +7 (812) 332 1114
fax: +7 (812) 279 9053

Singapore

Vacon Plc
Singapore Representative Office
102F Pasir Panjang Road
#02-06 Citilink Warehouse Complex
Singapore 118530
telephone: +65 6278 8533
fax: +65 6278 1066

Spain

Vacon Drives Ibérica S.A.
Miquel Servet, 2. P.I. Bufalvent
08243 Manresa
telephone: +34 93 877 45 06
fax: +34 93 877 00 09

Sweden

Vacon AB
Torget 1
172 67 Sundbyberg
telephone: +46 (0)8 293 055
fax: +46 (0)8 290 755