



USER'S MANUAL
NX FREQUENCY CONVERTERS

FIRE MODE PID APPLICATION
ASFIFF11

INDEX

1. INTRODUCTION	3
2. Fire Mode PID Application – Parameter lists	4
2.1 Monitoring values (Control keypad: menu M1)	5
2.2 Input signals (Control keypad: Menu M2 → G2.2).....	6
2.3 Output signals (Control keypad M2 → G2.3)	7
2.4 Fire Mode (Control keypad M2 -> G2.10).....	8
3. DESCRIPTION OF PARAMETERS	9
3.1 FIRE MODE PARAMETERS	9
Frequency reference signal logic in Fire Mode PID Application	10

FIRE MODE PID APPLICATION

1. INTRODUCTION

The application is functionally the same as the PID application (ASFIF05) with the addition of the fire mode features. Fire mode is selected via a digital input (programmable). The frequency is set according to logic in Figure 1. When fire mode is active, a fire mode warning (A81) is brought up on the display. When running in fire mode, the converter is programmed to enable the user to run the converter until either the digital input is removed or the converter is damaged.

Additional features when fire mode is selected:

- Run enable always active
- Run request always active
- Direction change not allowed
- Fault signal on digital outputs inactive
- Possible to connect fire mode signal to digital outputs
- Software generated faults are changed to warnings (Drive does not stop)
- Forced reset of hardware system faults (Delay time is set with parameter P2.10.5)
- Fire Mode frequency reference can be PID-output or two selectable preset speeds
- Monitor value V1.22 is stored if fire mode have been used (Counter)

2. FIRE MODE PID APPLICATION – PARAMETER LISTS

On the next pages you will find the lists of parameters within the respective parameter groups. The parameter descriptions are given on pages 9.

Column explanations:

Code	= Location indication on the keypad; Shows the operator the present parameter number
Parameter	= Name of parameter
Min	= Minimum value of parameter
Max	= Maximum value of parameter
Unit	= Unit of parameter value; Given if available
Default	= Value preset by factory
Cust	= Customer's own setting
ID	= ID number of the parameter (used with PC tools)
	= On parameter code: Parameter value can only be changed after the frequency converter has been stopped.

2.1 Monitoring values (Control keypad: menu M1)

The monitoring values are the actual values of parameters and signals as well as statuses and measurements. Monitoring values cannot be edited.

See Vacon NX User's Manual, Chapter 7 for more information.

Code	Parameter	Unit	ID	Description
V1.1	Output frequency	Hz	1	Output frequency to motor
V1.2	Frequency reference	Hz	25	Frequency reference to motor control
V1.3	Motor speed	rpm	2	Motor speed in rpm
V1.4	Motor current	A	3	
V1.5	Motor torque	%	4	
V1.6	Motor power	%	5	Motor shaft power
V1.7	Motor voltage	V	6	
V1.8	DC link voltage	V	7	
V1.9	Unit temperature	°C	8	Heatsink temperature
V1.10	Voltage input	V	13	AI1
V1.11	Current input	mA	14	AI2
V1.12	Analogue input 3		27	AI3
V1.13	Analogue input 4		28	AI4
V1.14	DIN1, DIN2, DIN3		15	Digital input statuses
V1.15	DIN4, DIN5, DIN6		16	Digital input statuses
V1.16	DO1, RO1, RO2		17	Digital and relay output statuses
V1.17	Analogue I _{out}	mA	26	A01
V1.18	PID Reference	%	20	In percent of the maximum frequency
V1.19	PID Actual value	%	21	In percent of the max actual value
V1.20	PID Error value	%	22	In percent of the max error value
V1.21	PID Output	%	23	In percent of the max output value
V1.22	Fire mode used	x	1510	Counter, how many times fire mode have been in use

Table 1. Monitoring values

2.2 Input signals (Control keypad: Menu M2 → G2.2)

Code	Parameter	Min	Max	Unit	Default	Cust	ID	Note
P2.2.1	DIN2 function	0	15		1		319	0=Not used 1=External fault cc 2=External fault oc 3=Run enable 4=Acc/Dec time selection 5=CP: I/O terminal 6=CP: Keypad 7=CP: Fieldbus 8=Forward/Reverse 9=Jogging frequency (cc) 10=Fault reset (cc) 11=Acc/Dec prohibit (cc) 12=DC braking command 13=Motor pot. UP (cc) 14=Fire Mode 15=Fire mode preset reference selection, 1 (oc) or 2 (cc)
P2.2.2	DIN3 function	0	15				301	0=Not used 1=External fault cc 2=External fault oc 3=Run enable 4=Acc/Dec time selection 5=CP: I/O terminal 6=CP: Keypad 7=CP: Fieldbus 8=Forward/Reverse 9=Jogging frequency (cc) 10=Fault reset (cc) 11=Acc/Dec prohibit (cc) 12=DC braking command 13=Motor pot.DOWN (cc) 14=Fire Mode 15=Fire mode reference selection, PID or Preset
P2.2.3	DIN5 function	0	15				330	0=Not used 1=External fault cc 2=External fault oc 3=Run enable 4=Acc/Dec time selection 5=CP: I/O terminal 6=CP: Keypad 7=CP: Fieldbus 8=Forward/Reverse 9=Jogging frequency (cc) 10=Fault reset (cc) 11=Acc/Dec prohibit (cc) 12=DC braking command 13=Enable PID reference 14=Fire Mode 15=Fire mode reference selection, PID or Preset

Table 2. Digital input functions, G2.2

2.3 Output signals (Control keypad M2 → G2.3)

Code	Parameter	Min	Max	Unit	Default	Cust	ID	Note
P2.3.6	Digital output 1 function	0	21		1		312	0=Not used 1=Ready 2=Run 3=Fault 4=Fault inverted 5=FC overheat warning 6=Ext. fault or warning 7=Ref. fault or warning 8=Warning 9=Reversed 10=Preset speed 11=At speed 12=Mot. regulator active 13=OP freq. limit superv.1 14=OP freq. limit superv.2 15=Torque limit superv. 16=Ref. limit supervision 17=External brake control 18=Control place: IO 19=FC temp. limit superv. 20=Unrequested direction 21=Ext. brake control inv. 22=Thermistor Fault/Warn. 23=Fieldbus digital input. 24=Fire mode selected.
P2.3.7	Relay output 1 function	0	21		2		313	As parameter 2.3.6
P2.3.8	Relay output 2 function	0	21		3		314	As parameter 2.3.6

Table 3. Digital output functions, G2.3

2.4 Fire Mode (Control keypad M2 -> G2.10)

Code	Parameter	Min	Max	Unit	Default	Cust	ID	Note
P2.10.1	Fire mode function	0	1		0		1501	0=Closing contact 1=Opening contact
P2.10.2	Fire mode preset reference selection	0	1		0		1502	0=Not inverted 1=Inverted
P2.10.3	Fire mode min frequency	Par 2.1.1	Par. 2.1.2	Hz	15,00		1503	Min frequency when in fire mode
P2.10.4	Fire mode preset frequency 1	Par 2.1.1	Par 2.1.2	Hz	35,00		1504	Fire mode preset frequency reference 1
P2.10.5	Fire mode preset frequency 2	Par 2.1.1	Par 2.1.2	Hz	50,00		1505	Fire mode preset frequency reference 2
P2.10.6	Fire mode forced reset delay	0,50	10,00	s	5,00		1506	Delay time for forced reset when in fire mode

Table 4. Fire Mode parameters, G2.10

3. DESCRIPTION OF PARAMETERS

3.1 Fire mode parameters

2.10.1 *Fire mode function*

- 0 Closing contact
- 1 Opening contact

2.10.2 *Fire mode preset reference selection*

- 0 Not inverted
- 1 Inverted

2.10.3 *Fire mode min frequency*

Sets the min frequency when the Fire Mode is active

2.10.4 *Fire mode preset frequency 1*

Parameter value is automatically limited between the minimum and maximum frequencies (P2.1.1, P2.1.2)

2.10.5 *Fire mode preset frequency 2*

Parameter value is automatically limited between the minimum and maximum frequencies (P2.1.1, P2.1.2)

2.10.6 *Fire mode forced reset delay*

Time delay before forced reset after a hardware generated fault.

4. FREQUENCY REFERENCE SIGNAL LOGIC IN FIRE MODE PID APPLICATION

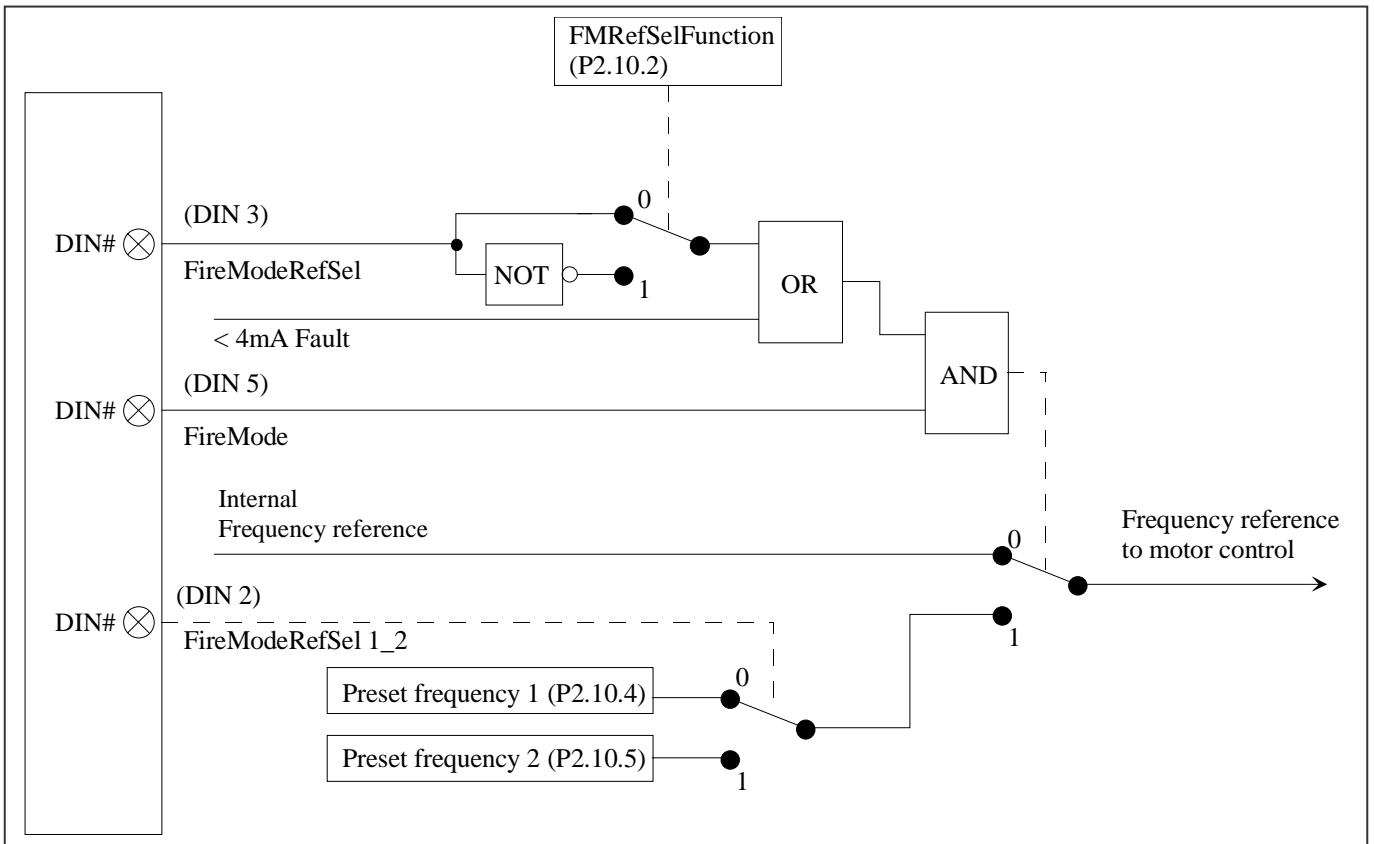

Figure 1. Frequency reference logic of the Fire Mode PID Application when running in Fire Mode

Vaasa

Vacon Plc (Head office and production)
Runsorintie 7
65380 Vaasa
firstname.lastname@vacon.com
telephone: +358 (0)201 2121
fax: +358 (0)201 212 205

Helsinki

Vacon Plc
Äyritie 12
01510 Vantaa
telephone: +358 (0)201 212 600
fax: +358 (0)201 212 699

Tampere

Vacon Plc
Vehnämyllynkatu 18
33700 Tampere
telephone: +358 (0)201 2121
fax: +358 (0)201 212 750

Vacon Traction Oy

Vehnämyllynkatu 18
33700 Tampere
telephone: +358 (0)201 2121
fax: +358 (0)201 212 710

SALES COMPANIES AND REPRESENTATIVE OFFICES:**Austria**

Vacon AT Antriebssysteme GmbH
Aumühlweg 21
2544 Leobersdorf
telephone: +43 2256 651 66
fax: +43 2256 651 66 66

Belgium

Vacon Benelux NV/SA
Interleuvenlaan 62
3001 Heverlee (Leuven)
telephone: +32 (0)16 394 825
fax: +32 (0)16 394 827

France

Vacon France s.a.s.
1 Rue Jacquard – BP72
91280 Saint Pierre du Perray CDIS
telephone: +33 (0)1 69 89 60 30
fax: +33 (0)1 69 89 60 40

Germany

Vacon GmbH
Gladbecker Strasse 425
45329 Essen
telephone: +49 (0)201 806 700
fax: +49 (0)201 806 7099

Great Britain

Vacon Drives (UK) Ltd.
18, Maizefield
Hinckley Fields Industrial Estate
Hinckley
LE10 1YF Leicestershire
telephone: +44 (0)1455 611 515
fax: +44 (0)1455 611 517

Italy

Vacon S.p.A.
Via F.lli Guerra, 35
42100 Reggio Emilia
telephone: +39 0522 276811
fax: +39 0522 276890

The Netherlands

Vacon Benelux BV
Weide 40
4206 CJ Gorinchem
telephone: +31 (0)183 642 970
fax: +31 (0)183 642 971

Norway

Vacon AS
Langgata 2
3080 Holmestrand
telephone: +47 330 96120
fax: +47 330 96130

PR China

Vacon Suzhou Drives Co. Ltd.
Blk 11A
428 Xinglong Street
Suchun Industrial Square
Suzhou 215126
telephone: +86 512 6283 6630
fax: +86 512 6283 6618

Vacon Suzhou Drives Co. Ltd.
Beijing Office
A205, Grand Pacific Garden Mansion
8A Guanhua Road
Beijing 100026
telephone: +86 10 6581 3734
fax: +86 10 6581 3754

Russia

ZAO Vacon Drives
Bolshaja Jakimanka 31,
stroenie 18
109180 Moscow
telephone: +7 (095) 974 14 47
fax: +7 (095) 974 15 54

ZAO Vacon Drives
2ya Sovetskaya 7, office 210A
191036 St. Petersburg
telephone: +7 (812) 332 1114
fax: +7 (812) 279 9053

Singapore

Vacon Plc
Singapore Representative Office
102F Pasir Panjang Road
#02-06 Citilink Warehouse Complex
Singapore 118530
telephone: +65 6278 8533
fax: +65 6278 1066

Spain

Vacon Drives Ibérica S.A.
Miquel Servet, 2. P.I. Bufalvent
08243 Manresa
telephone: +34 93 877 45 06
fax: +34 93 877 00 09

Sweden

Vacon AB
Torget 1
172 67 Sundbyberg
telephone: +46 (0)8 293 055
fax: +46 (0)8 290 755

Vacon distributor: