

Type	Value
Max.Weight	62kg/137lb
IP Class	IP21
UL Type	Type I

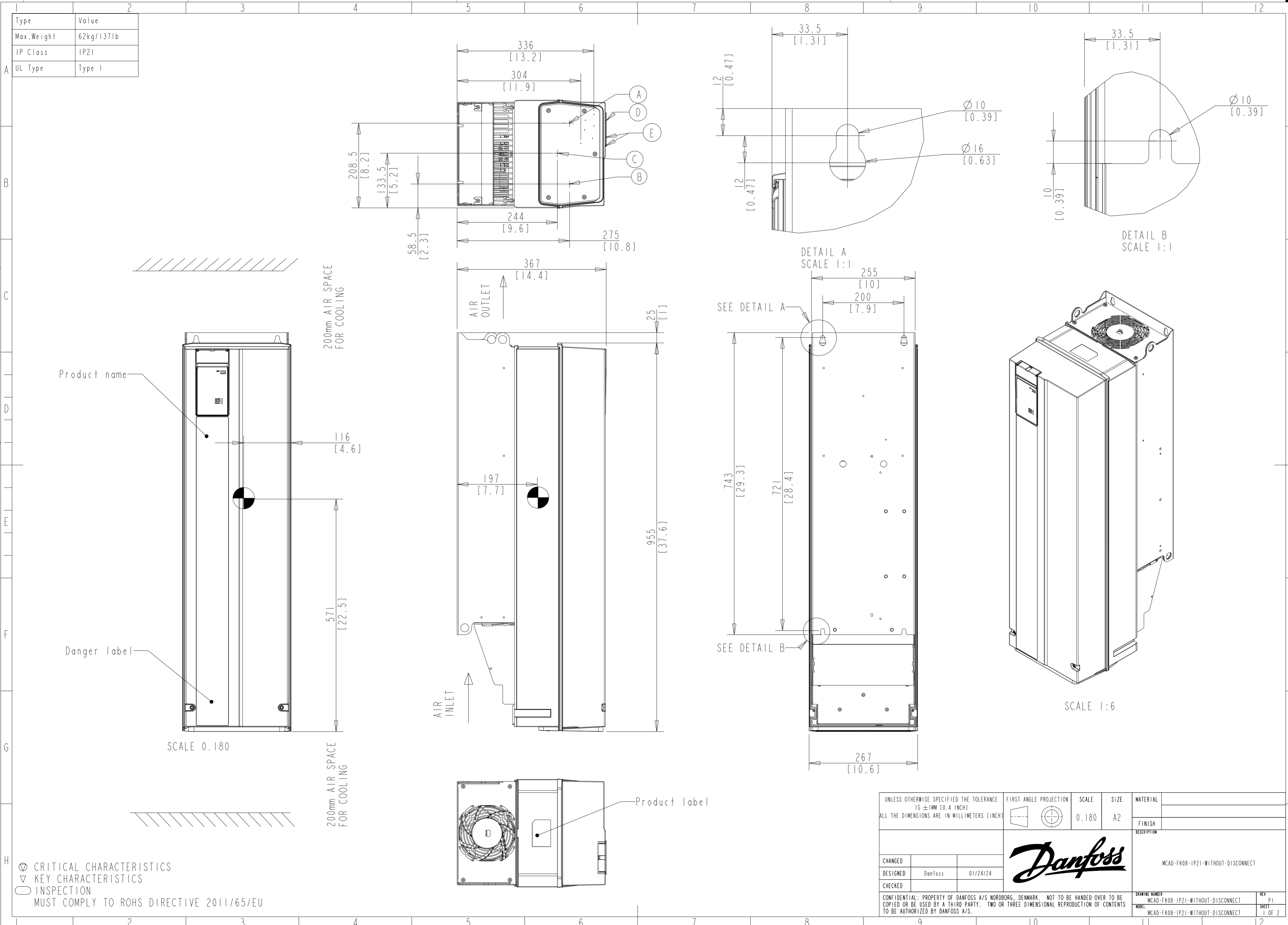

Ⓢ CRITICAL CHARACTERISTICS  
 ▽ KEY CHARACTERISTICS  
 ○ INSPECTION  
 MUST COMPLY TO ROHS DIRECTIVE 2011/65/EU

UNLESS OTHERWISE SPECIFIED THE TOLERANCE IS $\pm 1\text{MM}$ [0.4 INCH]. ALL THE DIMENSIONS ARE IN MILLIMETERS [INCH].		FIRST ANGLE PROJECTION	SCALE	SIZE	MATERIAL
			0.180	A2	
CHANGED		DESCRIPTION			
DESIGNED	Danfoss 01/24/24	MCAD-FK08-IP21-WITHOUT-DISCONNECT			
CHECKED		DRAWING NUMBER			
		MCAD-FK08-IP21-WITHOUT-DISCONNECT			
		REV			
		P1			
		SHEET			
		1 OF 2			

CONFIDENTIAL: PROPERTY OF DANFOSS A/S NORDBORG, DENMARK. NOT TO BE HANDED OVER TO BE COPIED OR BE USED BY A THIRD PARTY. TWO OR THREE DIMENSIONAL REPRODUCTION OF CONTENTS TO BE AUTHORIZED BY DANFOSS A/S.

SECTION A-A  
LINE TERMINALS

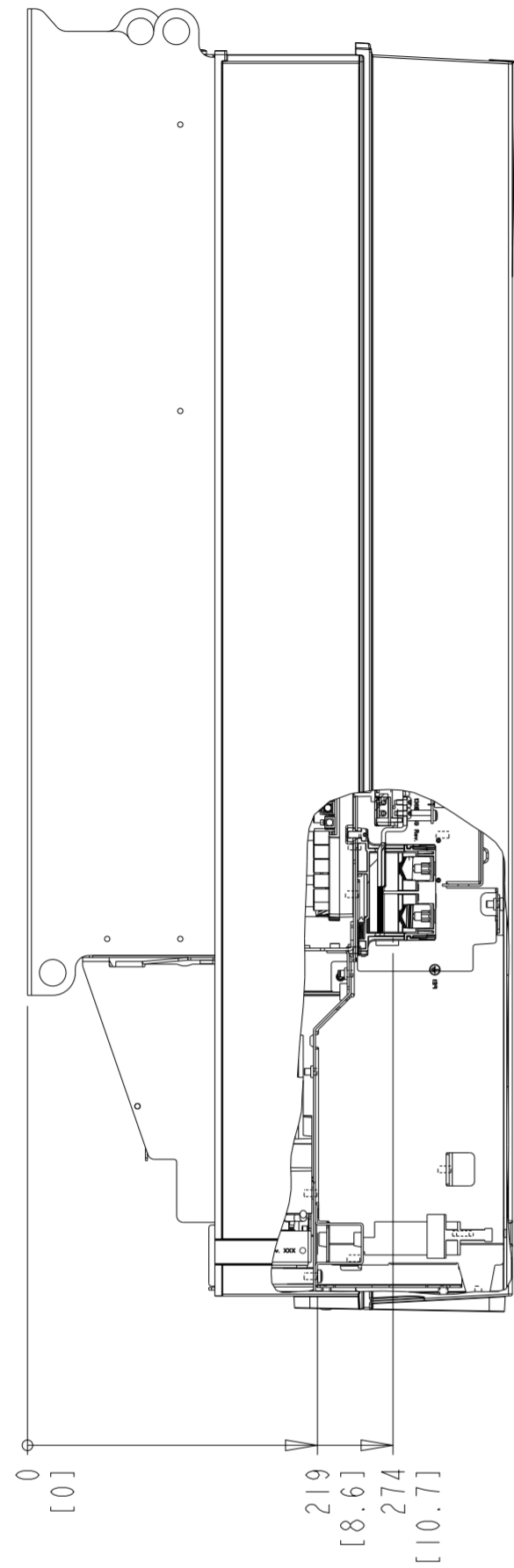

SCALE 1:5

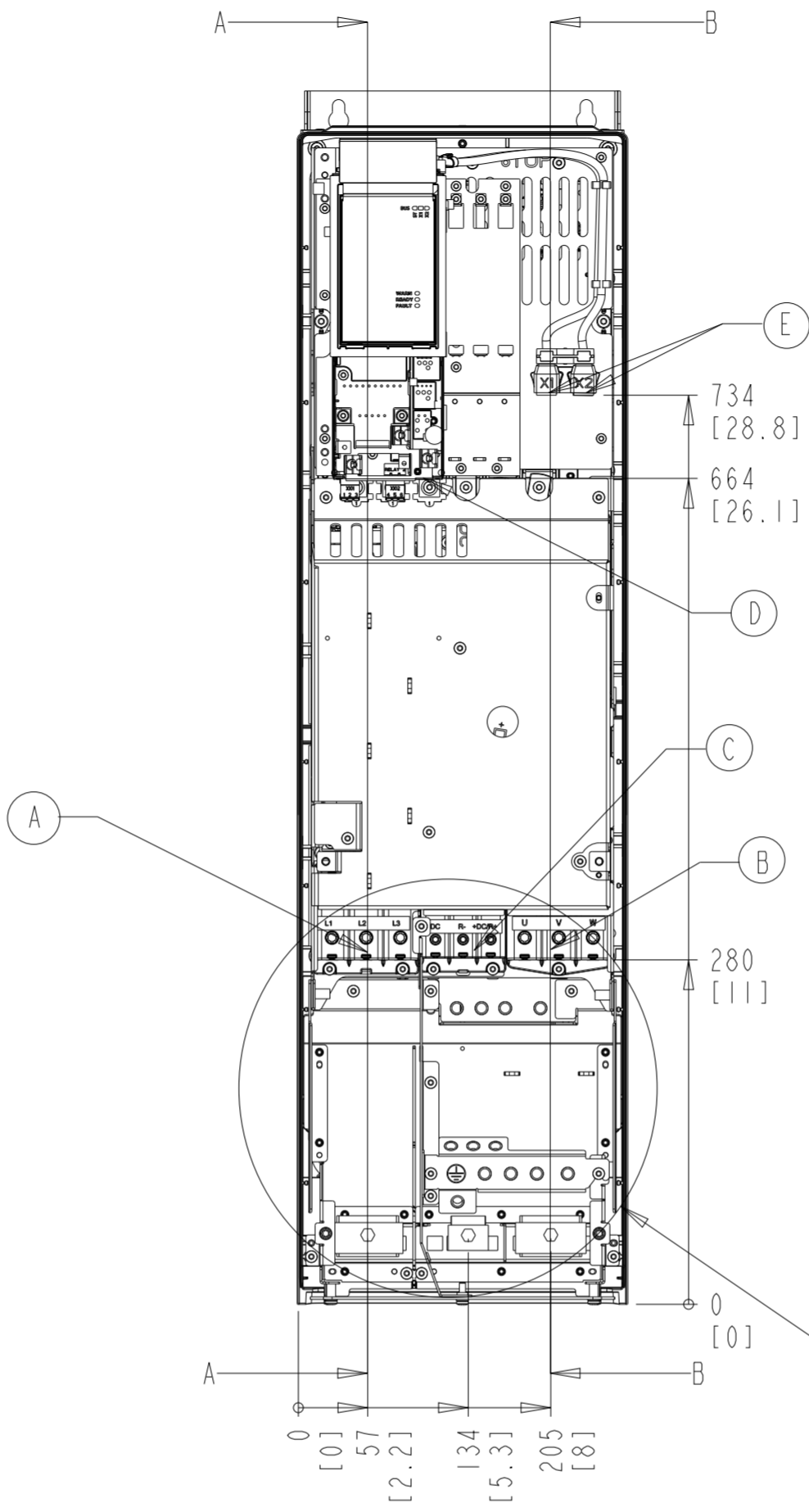

SECTION B-B  
MOTOR TERMINALS

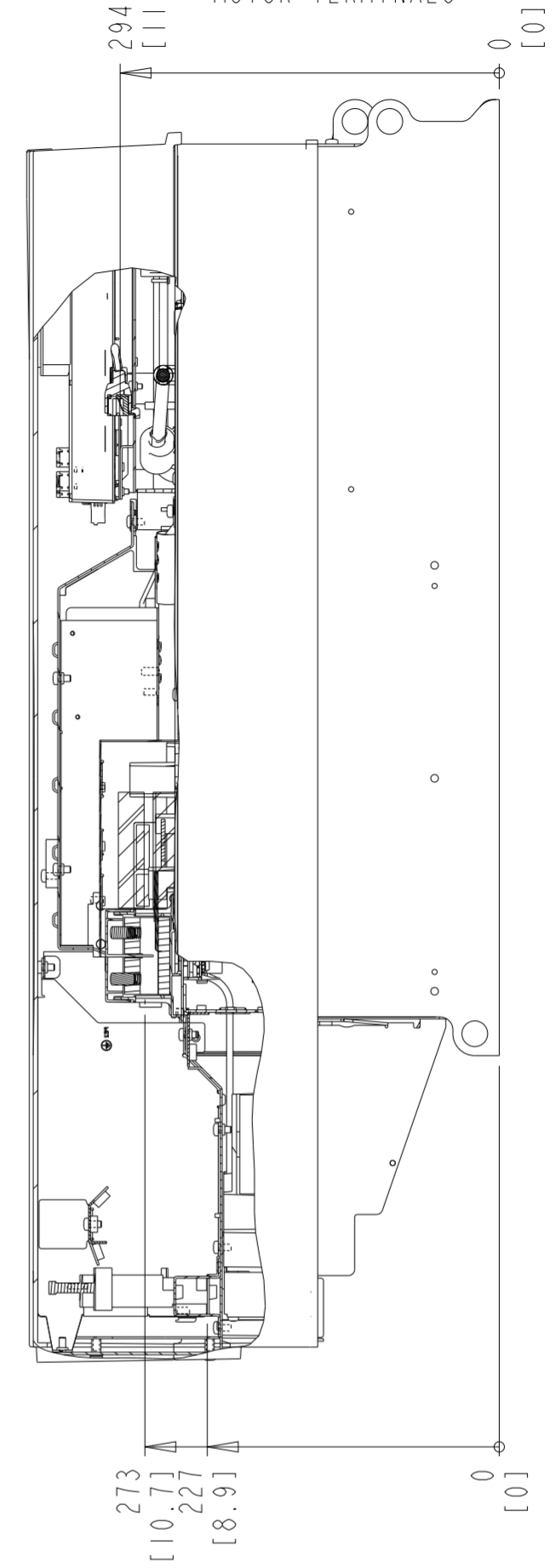

SEE DETAIL C

Position of connectors	
A	Line
B	Motor
C	Brake/DC
D	Interface X0
E	Interface X1/X2

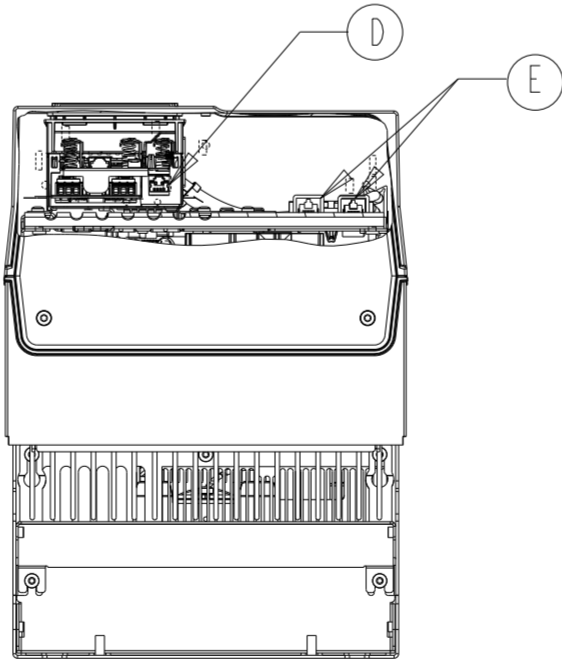

BOTTOM VIEW

EARTHING INFORMATION

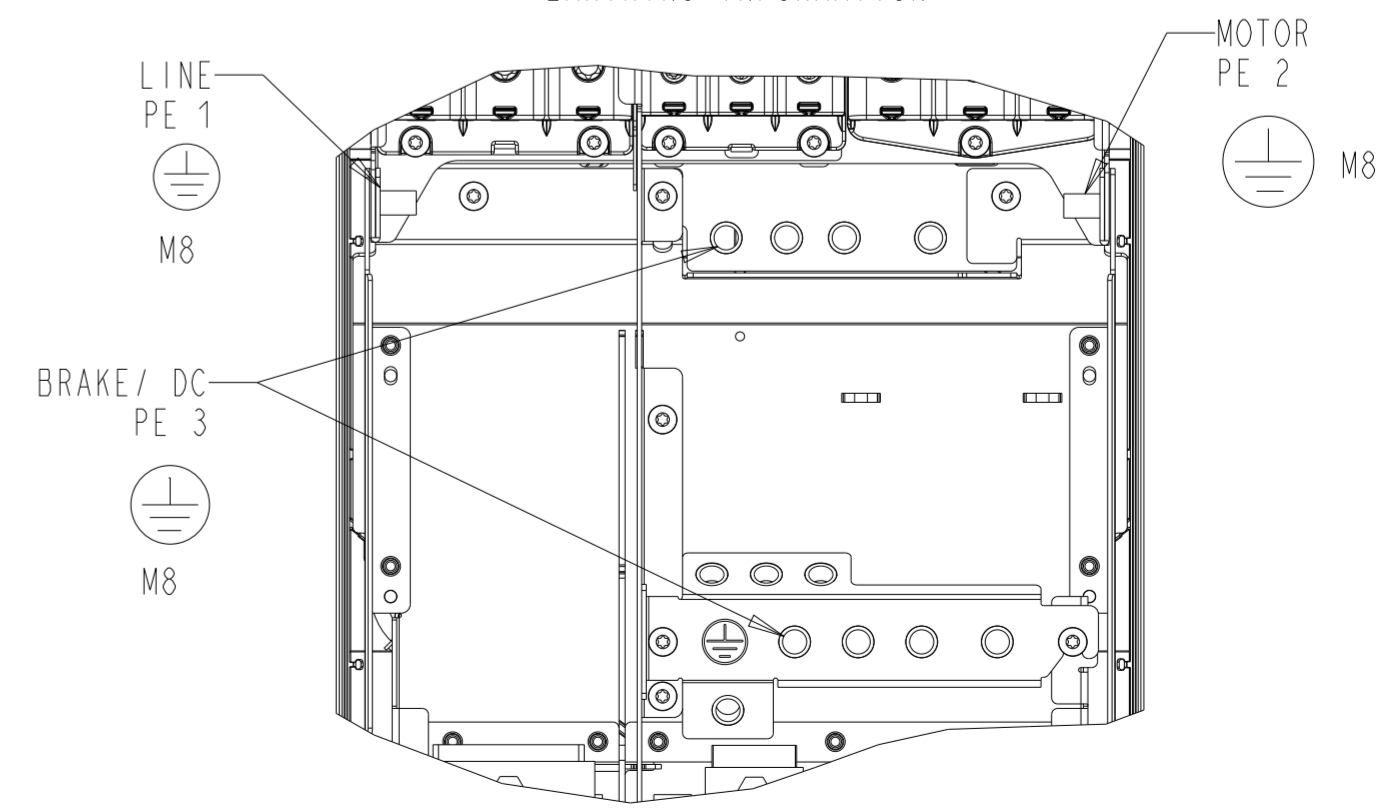

DETAIL C  
SCALE 1:3