

OPERATION

This cartridge assembly is a high pressure screen.

Not recommended as a substitute for hydraulic system filters.

SPECIFICATIONS

Performance graph

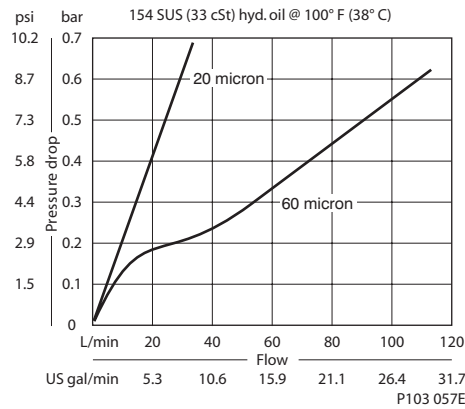

Schematic

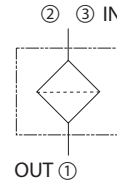

P103 059

Specifications

Pressure rating	207 bar [3000 psi]
Nominal flow: 20 micron	38 L/min [10 gpm]
Nominal flow: 60 micron	114 L/min [30 gpm]
Weight	0.47 kg [1.04 lbs]
Cavity	SDC20-3

DIMENSIONS

mm [in]

Cross section

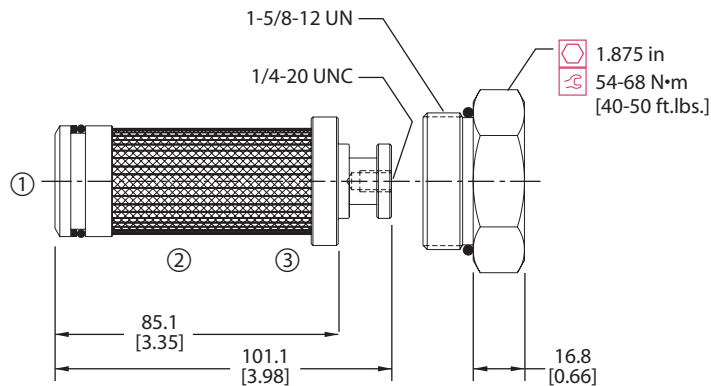

P103 058

ORDERING INFORMATION

CPF20 - 3 - B - 20S - P - 020

Seals
 B = Buna-N
 V = Viton

Seal kit
 120608
 120609

Housing and ports
 0 = No Housing
 6B=AL, 3/4 BSP
 8B=AL, 1 BSP
 12S=AL, #12 SAE
 16S=AL, #16 SAE
 Other housings available

Housing P/N
 No Housing
 CP20-3-6B
 CP20-3-8B
 CP20-3-12S
 CP20-3-16S

Filter mesh
 020 = 20 micron
 060 = 60 micron

Plug option
 P = Filter w/ #20 SAE hex plug
 Omit = Filter only

P103 060E