

OPERATION

Dual counterbalance HIC, 10-size, hydraulic vent with make-up checks. This is an internally piloted, low leakage assembly. The DCB10-MC uses two CB10-HV cartridges and four CP100-3 check valves, allowing free flow from the V port to the C ports and blocks flow in the reverse direction until the relief setting is reached, or until adequate pilot pressure has been applied to the opposite V port. Connect the T port to a tank line to allow for make-up flow into the circuit.



APPLICATIONS

Dual counterbalance HIC's are used for controlling loads in bidirectional motion such as wheel motor applications or for cylinders going over center. They are also suitable for use on the boom and dipper cylinder on an excavator. When make-up feature is needed, connect 'T' port to reservoir or charge system. This allows the load to be smoothly controlled with minimum energy loss. If load tries to run ahead of pump, pilot pressure will decrease and the relief section will throttle or close to prevent runaway. The T port is also useful in cylinder applications where directional valves (specifically proportional valves) are sensitive to flow intensification of powering the rod side. The DCB10-MC diverts flow directly to tank and bypasses the directional valve. This HIC technically replaces the 1EEC11-01.

SPECIFICATIONS

Rated pressure	350 bar [5075 psi]*
Rated flow at 22 bar (319 psi)	57 l/min [15 US gal/min]
Weight	2.39 kg [5.27 lb], Aluminum 5.04 kg [11.11 lb], Ductile
Pilot ratio	3.0:1, 4.5:1, 10.0:1
Cavity	CIB

SCHEMATIC

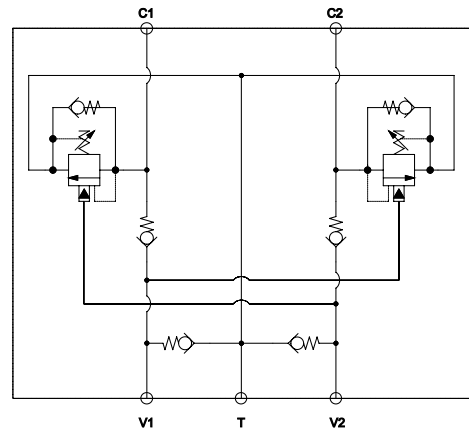

PERFORMANCE

