

OPERATION

This counterbalance valve is a 12 size metric, 3-ported, externally piloted low leakage, cartridge style valve with atmospheric vent. The check section allows free flow from the directional valve (port 2) to the load (port 3), while normally blocking flow from port 3 to port 2. Reverse flow is blocked until pilot pressure is applied at port 1. When the pressure at port 3 rises above the pressure setting, the integral relief valve is activated and vents the area behind the pilot piston.



APPLICATIONS

Atmospheric vented valves are applied when it is not practical to connect a separate vent line to the tank. Use a single counterbalance valve when the load is unidirectional, such as aerial lifts, cranes, or winches. In load holding applications, they are suitable for use as hose-break valves when installed near or within an actuator. Dual cartridges can be used for controlling loads bi-directionally in motor applications, or for cylinders going over center. Since this valve is piloted at port 1, no cross port drilling is required when dual cartridges are mounted nose to nose in an HIC.

CB - Counterbalance Valves

SPECIFICATIONS

Rated pressure	350 bar [5075 psi]*
Rated flow at 22 bar (319 psi)	140 l/min [37 US gal/min]
Weight	0.93 kg [2.05 lb]
Pilot ratio	4.7:1, 5.9:1, 6.9:1
Cavity	NCS12-3

* 350 bar with steel housing
 210 bar with aluminum housing

SCHEMATIC

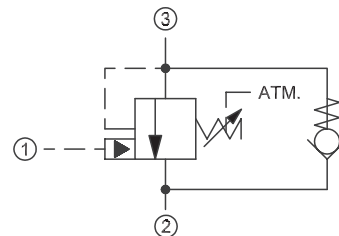

PERFORMANCE

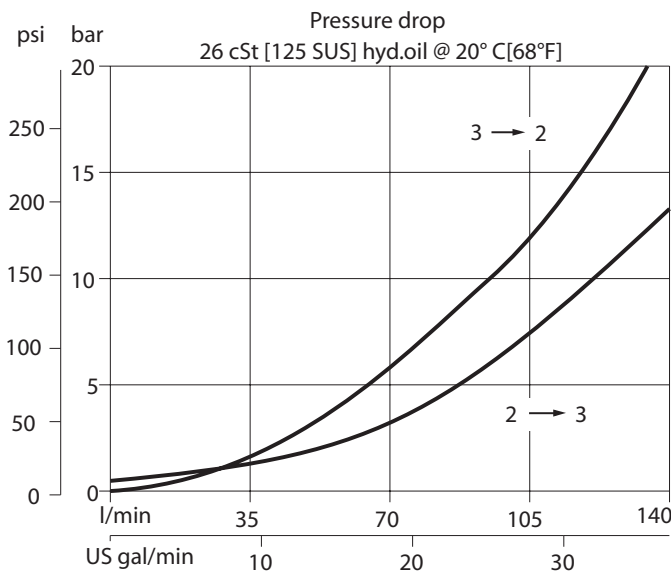

DIMENSIONS

mm [in]

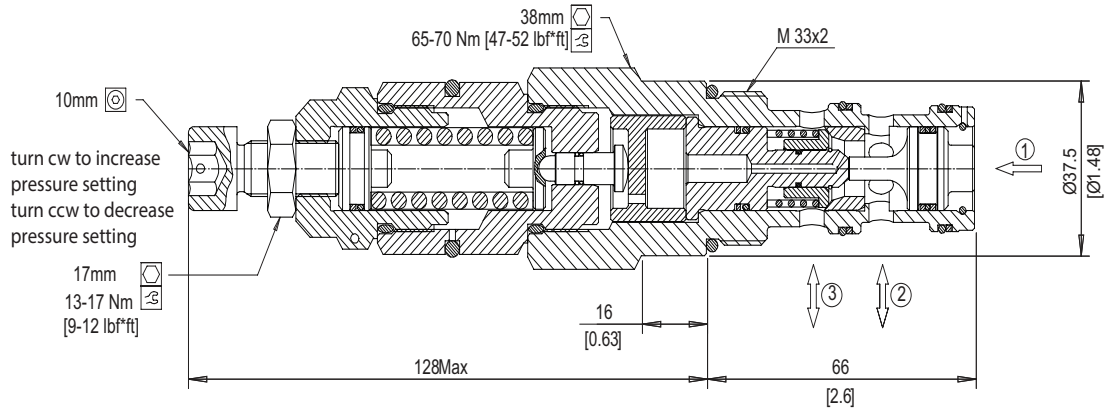

EXAMPLE CIRCUITS

Load Holding - Single Actuator

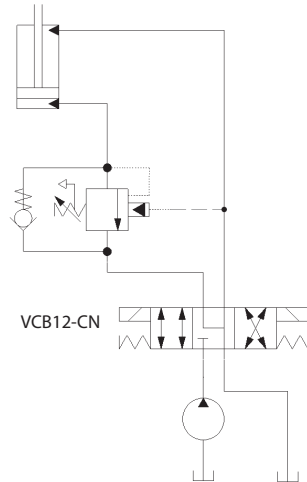

Load Holding - Double Actuator

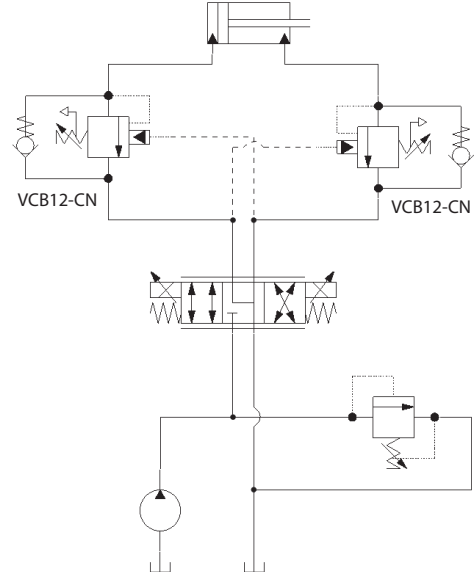

ORDERING INFORMATION

VCB12 - CN - 2 - A - 00 - B - XXX

VCB12-CN:
 Counterbalance Valve, Pilot Port 1, 12 size (metric), internal adjustment, atmospheric vent

Code	Pilot Ratio
A	6.9:1
B	4.7:1
C	5.9:1

Pressure Range

Code	Pilot Ratio A,C bar [psi]	Pilot Ratio B bar [psi]
1	25-140 [363-2031]	25-120 [363-1740]
2	70 - 250 [1015-3625]	60-200 [870-2900]
3	105 - 350 [1523-5075]	90-280 [1305-4060]

Code	Seal Material
B	Buna-N
V	Viton

Crack Pressure Setting [in bar]

XXX: No factory setting / no stamping

For customer specified settings, enter value in bar (Example 70 bar = 70; 125 bar = 125 etc.)

Housing & Ports	Housing Nomenclature
00: Cartridge Only	No Body
SE4B: AL, 1/2 BSP	NCS12-3-SE4B
SE6B: AL, 3/4 BSP	NCS12-3-SE6B
SES6B: Steel, 3/4 BSP	NCS12-3-SES6B
SE8S: AL, #8 SAE	NCS12-3-SE8S
SE12S: AL, #12 SAE	NCS12-3-SE12S