



# Directional Control Valves Catalog

## 2-Position, 3-Way, Atmospheric Vent

### CP722-1

### OPERATION

This valve is a 3-way hydraulically piloted spool with atmospheric vent.

### Schematic

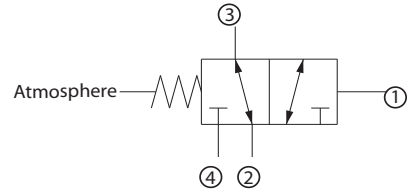

### SPECIFICATIONS

#### Theoretical performance

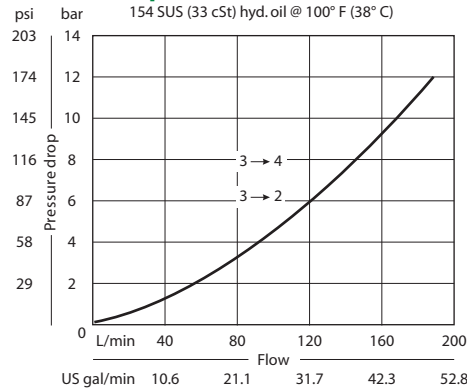

#### Specifications

Rated pressure	210 bar [3000 psi]
Rated flow at 7 bar [100 psi]	130 l/min [34 US gal/min]
Weight	0.61 kg [1.34 lb]
Cavity	CP16-4

### DIMENSIONS

mm [in]

Cross-sectional view

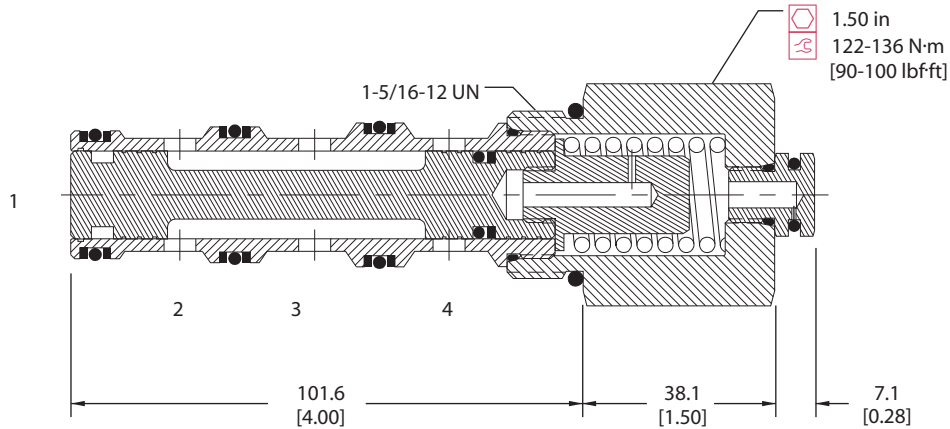

### ORDERING INFORMATION

CP722 - 1 - B - 16S - 150 - S1

#### Seals

- B = Buna-N
- V = Viton

#### Housing and ports

- 0 = No Housing
- 6B = AL, 3/4 BSP
- 8B = AL, 1 BSP
- 12S = AL, #12 SAE
- 16S = AL, #16 SAE
- Other housings available

Seal kit  
120025  
120026

#### Housing P/N

- No Housing
- CP16-4-6B
- CP16-4-8B
- CP16-4-12S
- CP16-4-16S

#### Spool seals

- S1 = No seals
- S2 = Seal at bottom of spool

#### Shift pressure

- | Shift pressure (bar) | Shift pressure (psi) |
|----------------------|----------------------|
| 040                  | 2.8 [40]             |
| 080                  | 5.5 [80]             |
| 150                  | 10.3 [150]           |
- shift pressure assumes no seals