



Directional Control Valves Catalog

Hydraulically Piloted, Spool

DV16-P5-23-01

OPERATION

This valve is a three way double hydraulically piloted spool.

Schematic

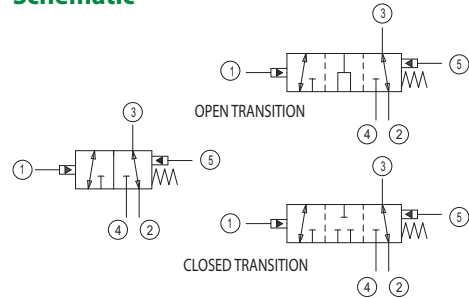

SPECIFICATIONS

Pressure drop
33 cSt [154 SUS] hyd.oil at 38°C [100°F]

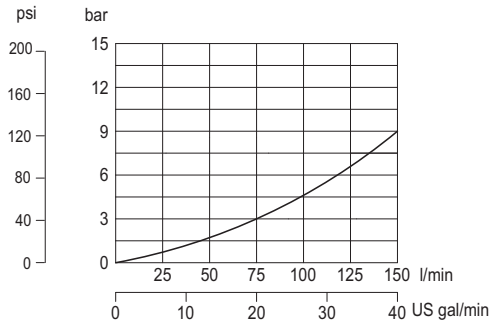

Specifications

Rated pressure	210 bar [3000 psi]
Rated flow at 7 bar [100 psi]	130 l/min [34 US gal/min]
Weight	0.67 kg [1.47 lb]
Cavity	SDC16-5S

DIMENSIONS

mm [in]

Cross-sectional view

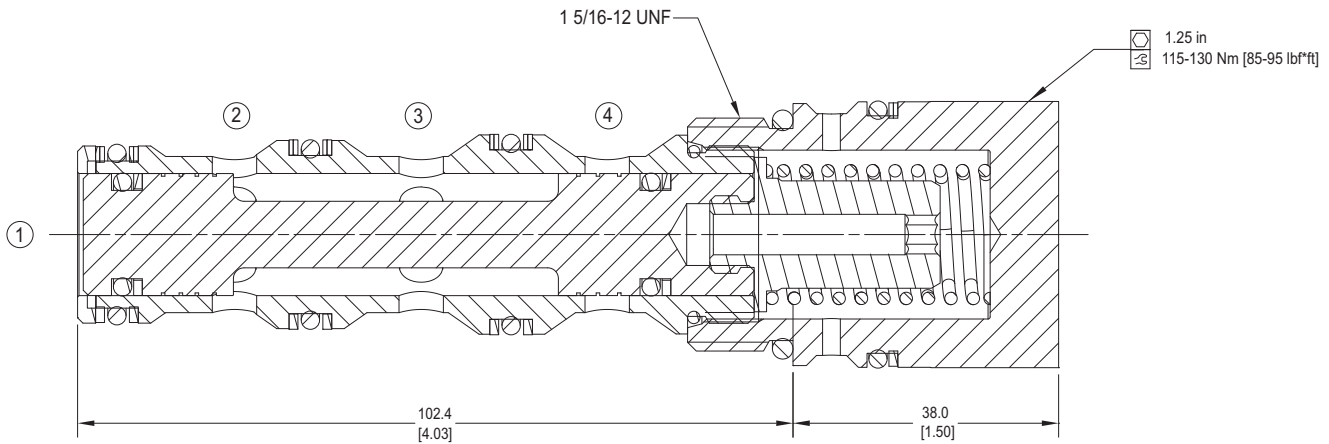

ORDERING INFORMATION

DV16-P5-23-01 - OT - S1 - B - 2.75 - 12S

Directional Valve, 2 Position
3 Way, Double Hydraulically
Piloted, 16 Size, Spool Type

Spool Transition

Code	Description
OT	Open Transition
CT	Closed Transition

Internal Seals

Code	Description
S1	Top Seals Only
S2	Top and Bottom Seals
S3	No Seals
S4	Bottom Seals Only

Bodies

Code	Ports & Material	Body Nomenclature
00	Cartridge Only	No Body
12S	#12 SAE, AL	SDC16-5S-12S
16S	#16 SAE, AL	SDC16-5S-16S
6B	3/4" BSP, AL	SDC16-5S-6B
8B	1" BSP, AL	SDC16-5S-8B

**Aluminum bodies are to be used for lower pressures less than 210 bar (3,000 psi)

Crack Pressure

Code	Crack Pressure
2.75	2.75 Bar [40 PSI]
5.5	5.5 Bar [80 PSI]
10	10 Bar [150 PSI]

Seal Option

Code	Seal Material	Seal Kit
B	Buna	11145379
V	Viton	11145380

DV - Directional Control Valves
DV16-P5-23-01