

OPERATION

This valve is a limited adjustment, pressure compensated, priority-type flow control valve.

SPECIFICATIONS

Theoretical performance

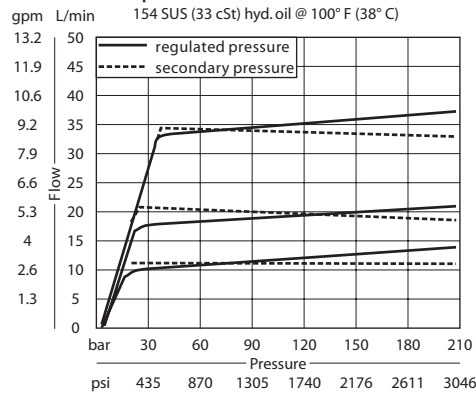

Schematic

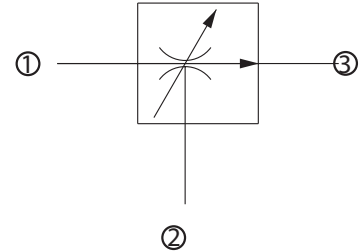

Specifications

Rated pressure	210 bar 3000 psi
Max regulated flow	23 l/min 6 US gal/min
Max inlet flow	38 l/min 10 US gal/min
Weight	0.24 kg 0.52 lb
Cavity	SDC10-3

DIMENSIONS

Cross-sectional view

mm in

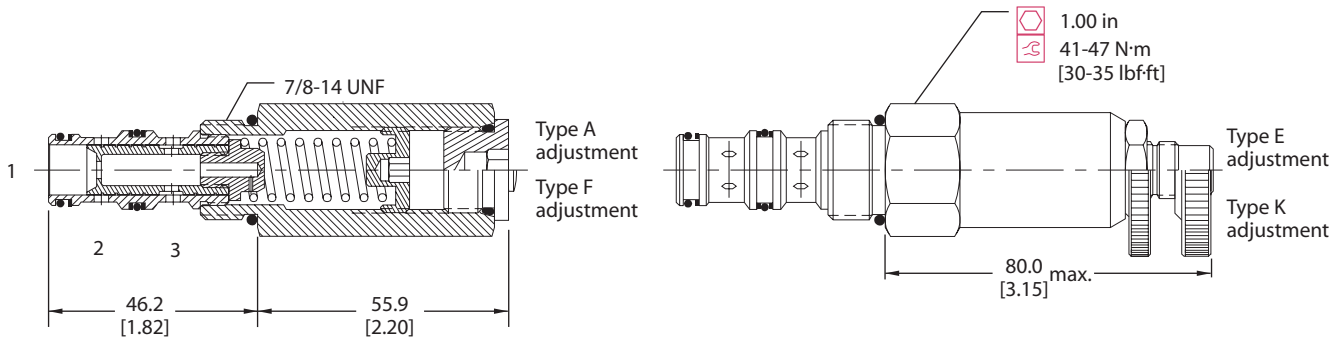

ORDERING INFORMATION

CP310 - 2 - B - 8S - A - 2.5

Seals
 B = Buna-N
 V = Viton

Seal kit
 120240
 120241

Housing and ports
 0 = No Housing
 SE3B = Al, 3/8 BSP
 SE4B = Al, 1/2 BSP
 6S = Al, #6 SAE
 8S = Al, #8 SAE
 Other housings available

Housing P/N
 No Housing
 SDC10-3-SE-3B
 SDC10-3-SE-4B
 CP10-3-6S
 CP10-3-8S

Regulated Flow

L/min	[US gal/min]
0.1 = .4	[0.1]
To	
6.0 = 22.7	[6.0]

Adjustment option
 A = Internal
 E = External
 F = Tamper resistant
 K = Knob