

**OPERATION**

The HLE10-OPO is a 10-size, high pressure, normally open, pilot-to-open, spring-biased differential-sensing logic element. It will modulate flow from 2 to 1 based on the spring control pressure, inlet pressure at port 1, and outlet pressure at port 3. The HLE10-OPO technically replaces the CP700-4L, but cavities are not interchangeable.



**APPLICATION**

Common applications include: as a pre-compensator for proportional directional control or flow controls, as well as a pressure control valve. A common application for this valve is as a pressure compensator when applied with a fixed, or adjustable orifice to create a pressure-compensated flow control. This ensures that flow rate, and resulting actuator speed is maintained regardless of pressure drop across the control orifice. Effective use of logic elements is a key to designing cost-effective circuits, and is limited only by the imagination of the designer.

**SPECIFICATION**

Rated Pressure*	350 bar [5075 psi]
Rated Flow at 7 bar [100 psi]	60 l/min [16 US gal/min]
Weight	0.14 kg [0.31 lbs]
Cavity	SDC10-3S

\* Rated Pressure based on NFPA fatigue test standards (at 1 Million Cycles).

**SCHEMATIC**

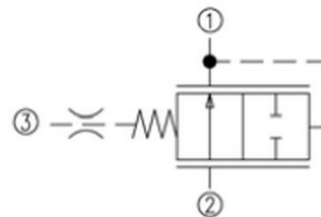

**PERFORMANCE CURVE**

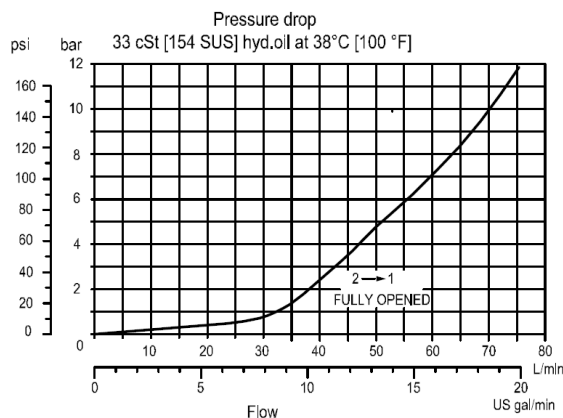

**DIMENSION**

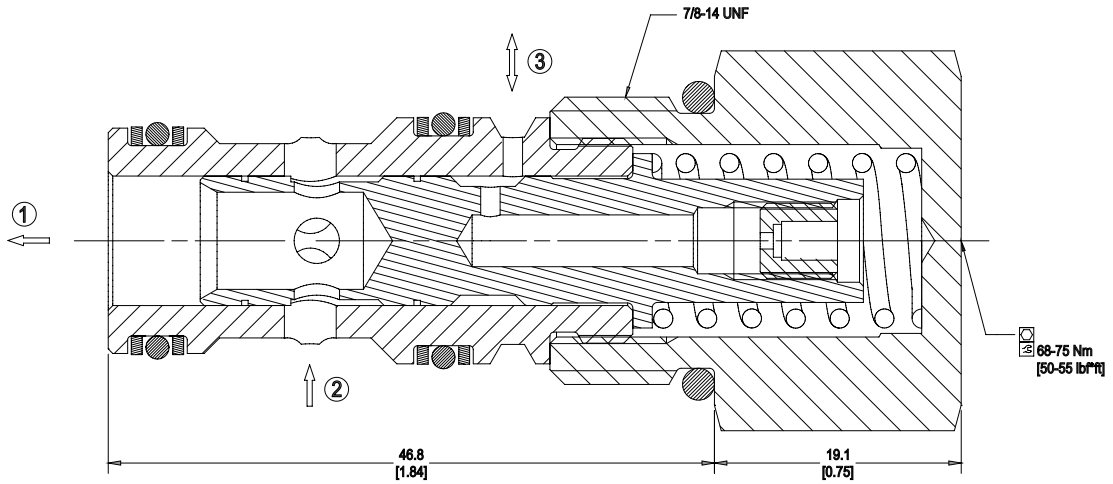

**EXAMPLE CIRCUITS**

Compensated Bi-directional Flow Control

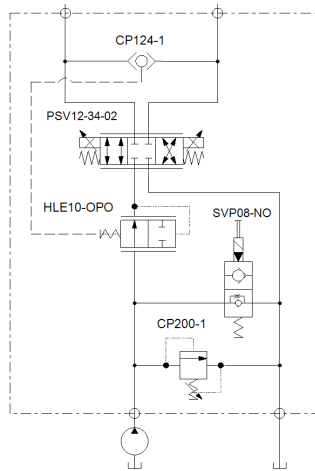

Proportional Pressure Reducing Valve

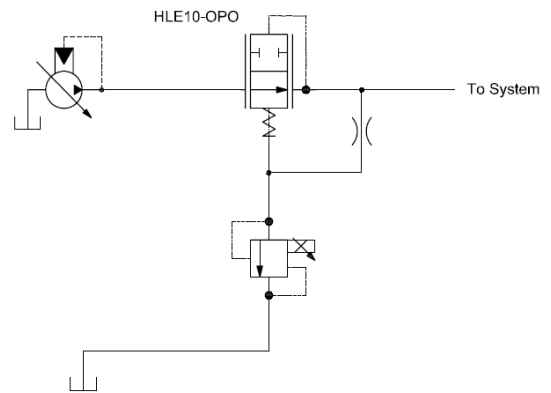

**ORDERING INFORMATION**

**HLE10:**  
High Pressure Logic Element, 10-size

**OPO:**  
Normally Open, Pilot to Open

**HLE10 - OPO - 2.75 - B - 00**

Differential Pressure Control

Code	Description
2.75	2.75 bar [40 psi]
5.5	5.5 bar [80 psi]
7.5	7.5 bar [110 psi]
10.0	10.0 bar [150 psi]
13.0	13.0 bar [190 psi]
15.0	15.0 bar [218 psi]

Code	Ports & Material	Body Nomenclature
00	Cartridge Only	No Body
6S	#6 SAE, AL	SDC10-3S-6S
8S	#8 SAE, AL	SDC10-3S-8S
S6S	#6 SAE, DUCTILE	SDC10-3S-S6S
S8S	#8 SAE, DUCTILE	SDC10-3S-S8S
3B	3/8 BSP, AL	SDC10-3S-3B
4B	1/2 BSP, AL	SDC10-3S-4B
S3B	3/8 BSP, DUCTILE	SDC10-3S-S3B
S4B	1/2 BSP, DUCTILE	SDC10-3S-S4B

Code	Seal Material	Seal kit
B	Buna	11126248
V	Viton	11126249