

OPERATION

The CP312-4 is a 16-size, flow control, priority type pressure compensator. Priority-type pressure compensators are four-ported valves that work in series with a fixed or variable control orifice. As with the restrictive-type valves, these valves maintain a constant pressure differential across the control orifice. However, rather than restricting flow when the differential pressure becomes too high, the priority-type pressure compensators open a fourth bypass port for all flow in excess of that demanded by the control orifice. Note that if the bypass port is blocked, the valve will function as a restrictive-type pressure compensator.

APPLICATION

Common applications include any circuit that requires compensated priority flow going to one actuator (for example, steering or charge pressure to a hydrostatic pump), and the remaining going to a secondary function (for example, a fan motor). Pressure compensators offer the circuit designer capability to add pressure compensation to any fixed or variable orifice. This ensures that flow, and resulting actuator speed, are maintained regardless of system and working pressures

SPECIFICATION

| | |
|--------------------------------------|---------------------------|
| Rated pressure | 210 bar [3000 psi] |
| Rated flow at 7 bar [100 psi] | 130 l/min [34 US gal/min] |
| Weight | 0.60 kg [1.32 lb] |
| Cavity | CP16-4 |

SCHEMATIC

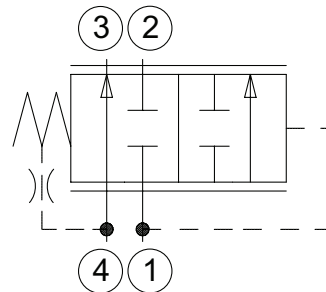

PERFORMANCE CURVE

Theoretical performance

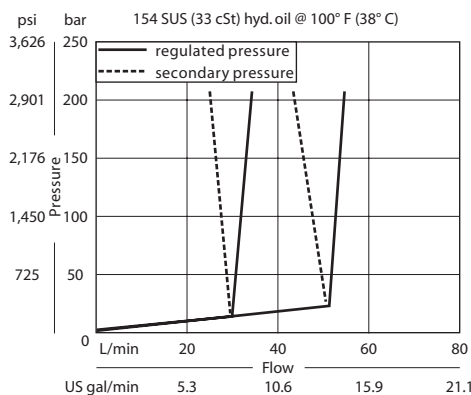

DIMENSION

mm [in]

Cross-sectional view

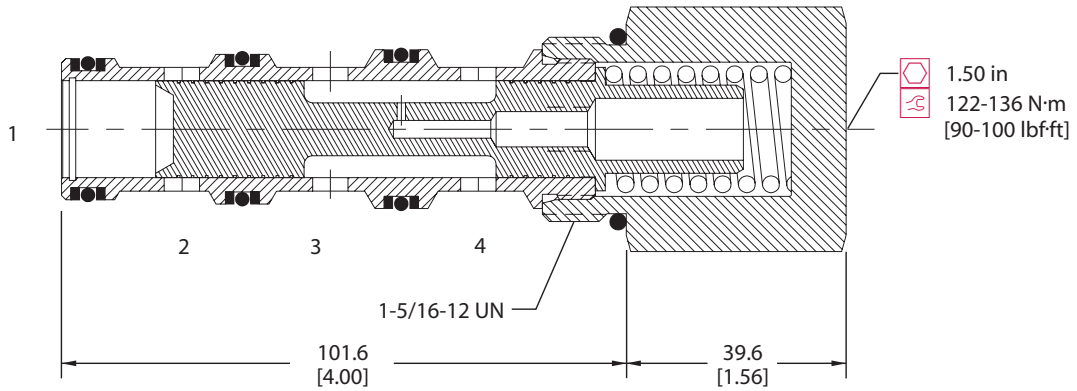

EXAMPLE CIRCUITS

Priority-type pressure Compensator operation

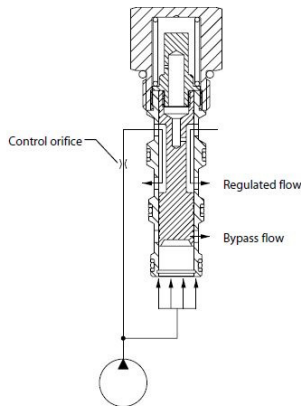

Post-Compensated Proportional Priority Flow Control

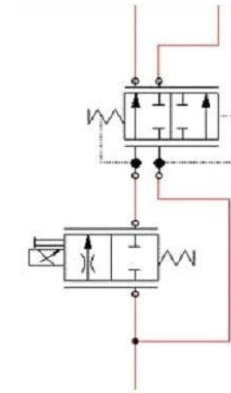

ORDERING INFORMAT

CP312 - 4 - B - 16S - 080

| | | | | | | | | | | | | | | | | | |
|---|--|---|--|-----|-------|-----|-------|------|-----|-------|------|-----|-------|-------|-----|--------|-------|
| <p>Seals</p> <p>B = Buna-N V = Viton</p> <p>Seal kit 120025 120026</p> | <p>Housing and ports</p> <p>0 = No housing 6B = AL, 3/4 BSP 8B = AL, 1 BSP 12S = AL, #12 SAE 16S = AL, #16 SAE Other housings available</p> <p>Housing P/N</p> <p>No housng CP16-4-6B CP16-4-8B CP16-4-12S CP16-4-16S</p> | <p>Differential Control Pressure</p> <table border="0"> <tr> <td></td> <td>bar</td> <td>[psi]</td> </tr> <tr> <td>040</td> <td>= 2.8</td> <td>[40]</td> </tr> <tr> <td>080</td> <td>= 5.5</td> <td>[80]</td> </tr> <tr> <td>110</td> <td>= 7.6</td> <td>[110]</td> </tr> <tr> <td>150</td> <td>= 10.3</td> <td>[150]</td> </tr> </table> | | bar | [psi] | 040 | = 2.8 | [40] | 080 | = 5.5 | [80] | 110 | = 7.6 | [110] | 150 | = 10.3 | [150] |
| | bar | [psi] | | | | | | | | | | | | | | | |
| 040 | = 2.8 | [40] | | | | | | | | | | | | | | | |
| 080 | = 5.5 | [80] | | | | | | | | | | | | | | | |
| 110 | = 7.6 | [110] | | | | | | | | | | | | | | | |
| 150 | = 10.3 | [150] | | | | | | | | | | | | | | | |