

OPERATION

This is a dual counterbalance HIC that mounts to DH motors with manifold mount porting.

Schematic

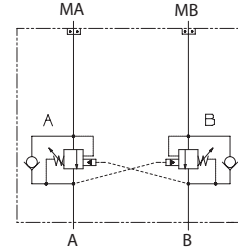

SPECIFICATIONS

Theoretical performance

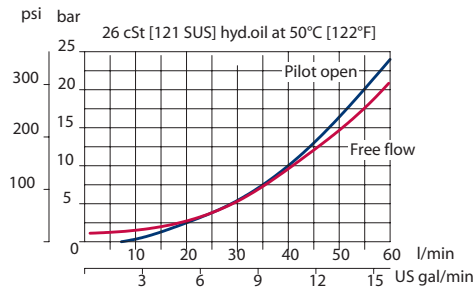

Specifications

Rated pressure	210 bar [3045 psi]
Rated flow at 22 bar [319 psi]	60 l/min [16 US gal/min]
Leakage	6 drops/min @ 70% of crack pressure
Weight	1.49 kg [3.28 lb]
Pilot ratio	3.0:1, 4.5:1, 10.0:1
Cartridge	CB10 HV
Service mount kit	11023864
Motor	DH

DIMENSIONS

Cross-sectional view

mm [in]

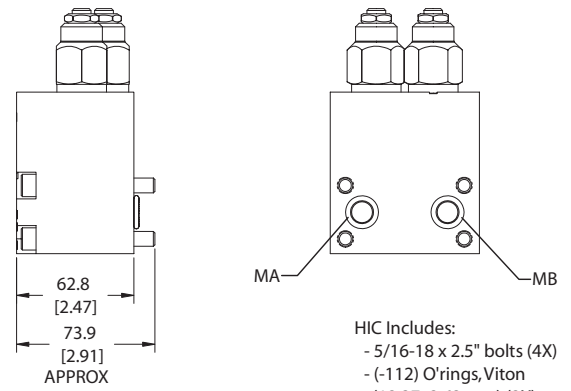
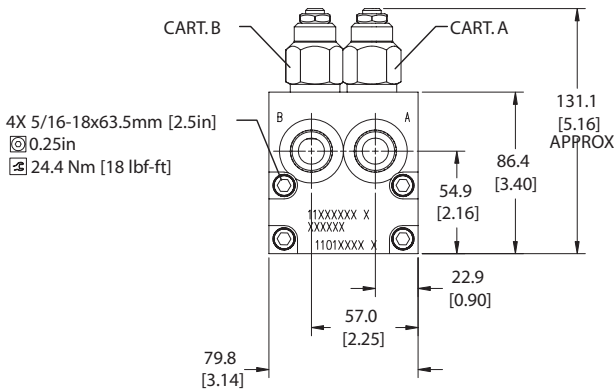

HIC Includes:
 - 5/16-18 x 2.5" bolts (4X)
 - (-112) O'rings, Viton (12.37x2.62 mm) (2X)

ORDERING INFORMATION

MM-DH-00-DCB10-HV-1-C-1-E-100-B-10S

