

OPERATION

This is a single counterbalance (B port) HIC with shuttle that mounts to OMP/OMR motors with BSP porting.

Schematic

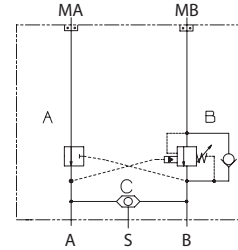

SPECIFICATIONS

Theoretical performance

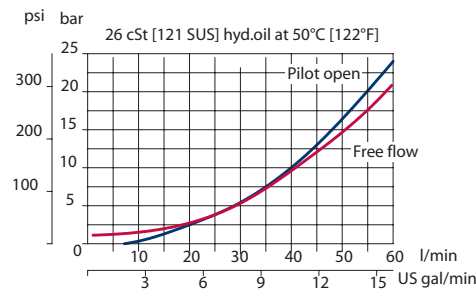

Specifications

Rated pressure	210 bar [3045 psi]
Rated flow at 22 bar [319 psi]	60 l/min [16 US gal/min]
Leakage	6 drops/min @ 70% of crack pressure
Weight	1.44 kg [3.17 lb]
Pilot ratio	3.0:1, 4.5:1, 10.0:1
Cartridge	CB10 HV
Shuttle	CP124-1
Plug	SDC10-V-3S-B1
Shuttle/drain port	#4 SAE (1/8 BSP)
Service mount kit	11023162
Motor	OMP/OMR

DIMENSIONS

Cross-sectional view

mm [in]

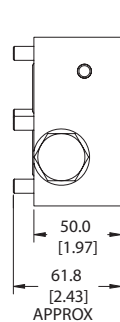
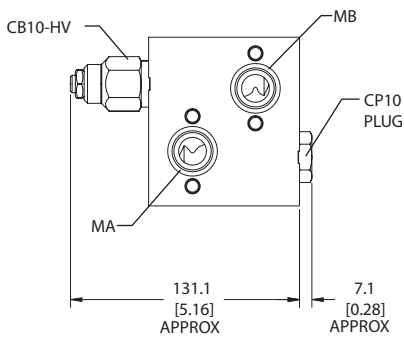

4X M8x1.25x50mm [1.97in]
 ⌀6mm
 ⚙️40 Nm [30 lbf-ft]

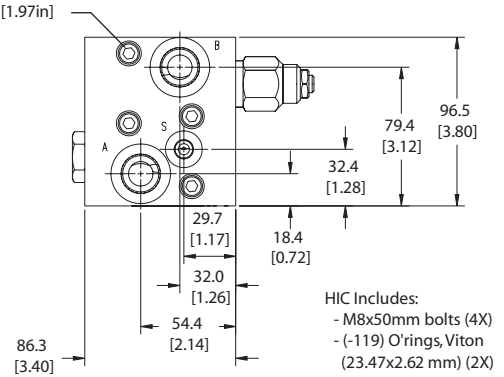

HIC Includes:
 - M8x50mm bolts (4X)
 - (-119) O-rings, Viton (23.47x2.62 mm) (2X)

MM - Motor Mount HICs Catalog
 MM-OMP/OMR-LS-BCB10-HV

ORDERING INFORMATION

MM-OMP/OMR-LS-BCB10-HV-1-C-1-E-100-B-10S

