



Proportional Valves Catalog

Flow Control, Pressure Compensated, Restrictive Type, Normally Open



PFC10-RO

OPERATION

This is a pressure-compensated, restrictive-type, normally-open, spool-type, proportional flow-control. Controlled flow is from port 1 to 2.

SPECIFICATIONS

Rated pressure	260 bar [3770 psi]
maximum Flow at rated pressure	PFC10-RO-10: 10 l/min [2.64 US gal/min] PFC10-RO-30: 30 l/min [7.9 US gal/min]
Leakage	420 cm ³ /min [25.6 in ³ /min] @ rated pressure
Weight	0.65 kg [1.43 lb]
Hysteresis	8% maximum
Threshold current	0.2 A (12 VDC coil) 0.1 A (24 VDC coil)
Maximum control current	1.8 A (12 VDC coil) 0.9 A (24 VDC coil)
Cavity	SDC10-2
Standard Coil	M19P 22 Watt

Theoretical performance

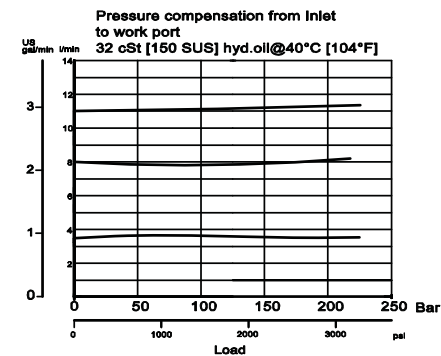
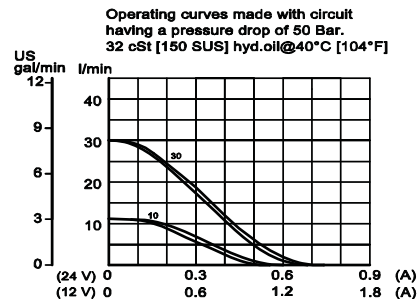

Schematic

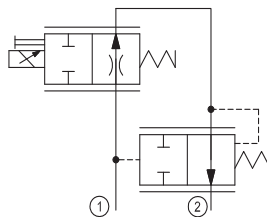

Cross-sectional view

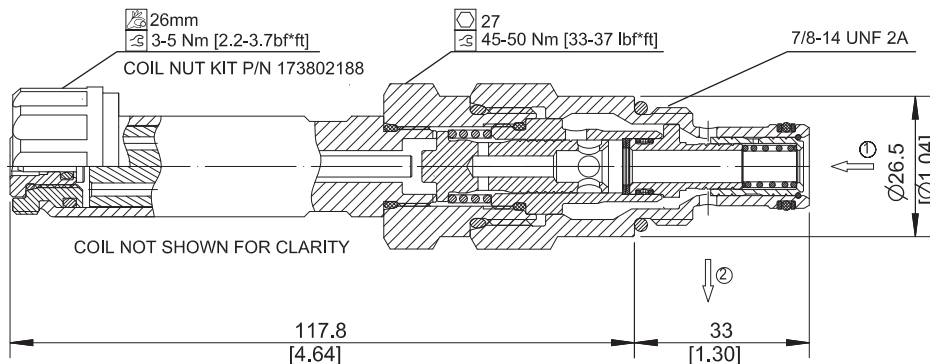

DIMENSIONS

mm [in]

ORDERING INFORMATION

PFC10-RO-30-12D-DE-SPS-B-00

Proportional Flow Control Valve, Pressure Compensated, Restrictive Type, Normally Open, 10 Size Cavity

Code	Max regulated flow
10	10 l/min
30	30 l/min

Code	Coil Voltage
00	No Coil
12D	12V DC
24D	24 V DC

Code	Coil Termination
00	No Coil
AJ	Amp Junior
DE	Deutsch
DN	DIN 43650

Code*	Manual Override
Omit	Push Pin (Standard)
SPS	Screw Style (Push-Type Valve)

Code	Seal	Seal Kit
B	Buna-N	354004019
V	Viton	354003419

Body & Ports	Body Nomenclature
00 = No housing	No Body
6S = Al, #6 SAE	CP10-2-6S
8S = Al, #8 SAE	CP10-2-8S
DG3B = Al, 3/8" BSP	SDC10-2-DG3B
DG4B = Al, 1/2" BSP	SDC10-2-DG4B
*Other housings available	

*PB (Push-Button) available upon request

Proportional Valves PFC10-RO