



Proportional Valves Catalog

Flow Control, Non-Compensated, Normally Open

CP518-PNO



OPERATION

This valve is a non-compensated, normally-open, proportional flow control.

SPECIFICATIONS

Rated pressure	210 bar [3000 psi]
Rated flow at 6 bar [80 psi]	12 l/min [3 US gal/min]
Weight	0.36 kg [0.80 lb]
Hysteresis	4% maximum
Threshold current	0.2 A (12 VDC coil) 0.1 A (24 VDC coil)
Maximum control current	1.2 A (12 VDC coil) 0.6 A (24 VDC coil)
Pressure differential	21 bar [300 psi] maximum
Cavity	SDC08-2
Standard Coil	M19P 22 Watt
Coil nut	173802114

Theoretical performance

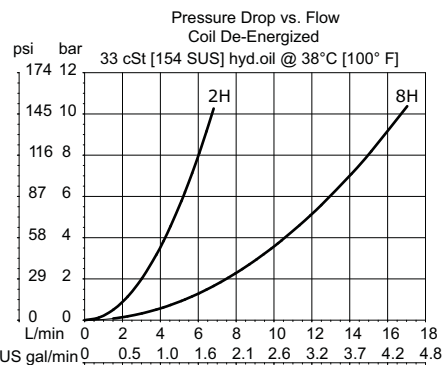
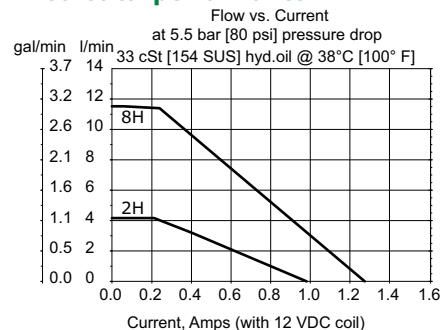

Schematic

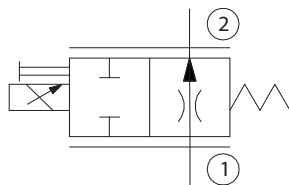

DIMENSIONS

mm [in]

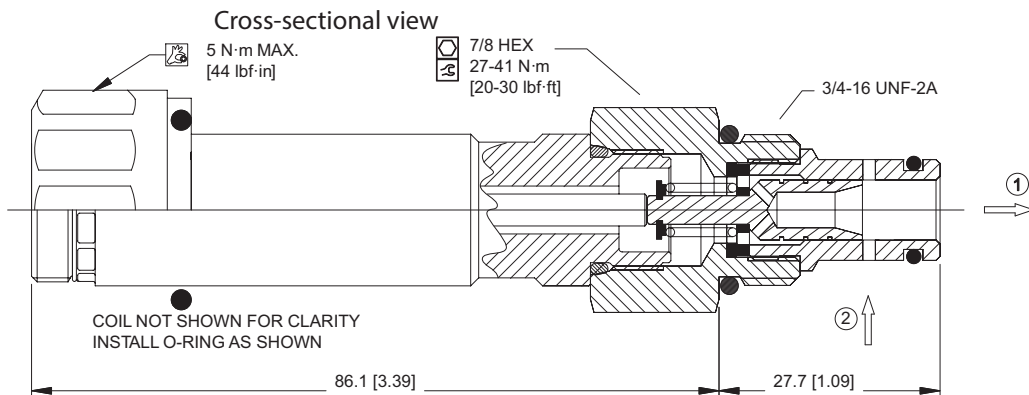

ORDERING INFORMATION

CP518-PNO-U-6S-2H-24-DE

Seals
U = Urethane
Seal kits 120591

Housing and ports
0 = Cartridge only
4S = AL, #4 SAE
6S = AL, #6 SAE
2B = AL, 1/4 BSP
3B = AL, 3/8 BSP

Housing P/N
No Housing
CP08-2-4S
CP08-2-6S
SDC08-2-DG-2B
SDC08-2-DG-3B

Voltage
00 = No coil
12 = 12 VDC
24 = 24 VDC

Flow code
2H
8H

Termination
00 = No connector
DE = Deutsch
DN = DIN 43650
FL = Lead wires
AJ = AMP Jr

Proportional Valves
CP518-PNO