



Proportional Valves Catalog

Relief, Pilot Operated, Normally Closed

PRV12-POC



OPERATION

This is a normally-closed, pilot-operated, proportional relief valve.

SPECIFICATIONS

Rated pressure	250 bar [3600 psi]
Rated flow	180 l/min [48 US gal/min]
Weight	0.62 kg [1.37 lb]
Hysteresis	10% maximum
Threshold current	0 A (12 VDC coil) 0 A (24 VDC coil)
Maximum control current	1.5 A (12 VDC coil) 0.8 A (24 VDC coil)
Cavity	SDC12-2
Standard Coil	M19P 22 Watt

Theoretical performance

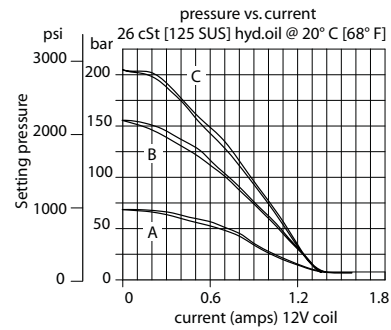

Schematic

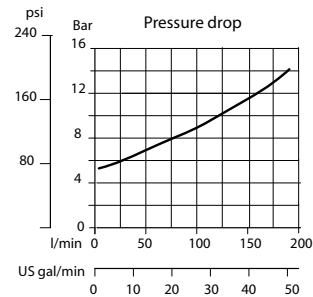
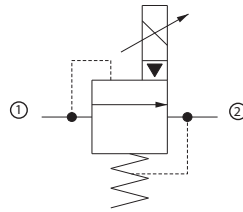

DIMENSIONS

mm [in]

Cross-sectional view

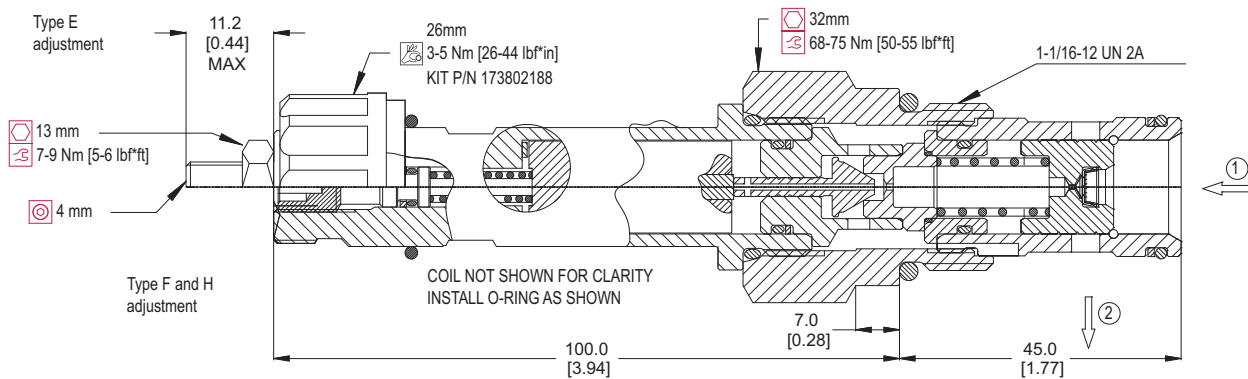

ORDERING INFORMATION

PRV12 - POC* - 215 - C - 12D - DE - E - B - 00

Code	Crack Pressure (Standard Settings)
55	55 bar [800 psi] Range A
135	135 bar 1950 B [psi] Range B
215	215 bar 3120 C [psi] Range C

Code	Pressure Range
A	25 - 65 bar [360 - 940 psi]
B	65 - 155 bar [940-2250 psi]
C	155 - 215 bar [2250-3120 psi]

Code	Coil Voltage
00	No Coil
12D	12V DC
24D	24 V DC

Code	Coil Termination
00	No Coil
AJ	Amp Junior
DE	Deutsch
DN	DIN 43650

Code	Adjustment Options
E	External
F	Tamper Resistant
H	Hidden

Code	Seal	Seal Kit
B	Buna-N	354001319
V	Viton	354001819

Body & Ports	Body Nomenclature
00 = No housing	No Body
10S = AL #10 SAE	CP12-2-10S
12S = AL #12 SAE	CP12-2-12S
DG4B = AL 1/2 BSP	SDC12-2-DG4B
DG6B = AL 3/4 BSP	SDC12-2-DG6B

Other housings available

Proportional Pressure Relieving Valve, Pilot Operated, Normally Closed, 12 Size Cavity.

*PRV12-IS2 is the same valve as PRV12-POC, with the following differences:
1) The -IS2 uses the M19P-12L or M19P-24L coil (low power)
2) The pressure is set at a higher flow.

The IS2 is designed specifically for fan drive applications where the valve is in a hot ambient engine compartment.

Proportional Valves
PRV12-POC