

Dimensions

mm [in]

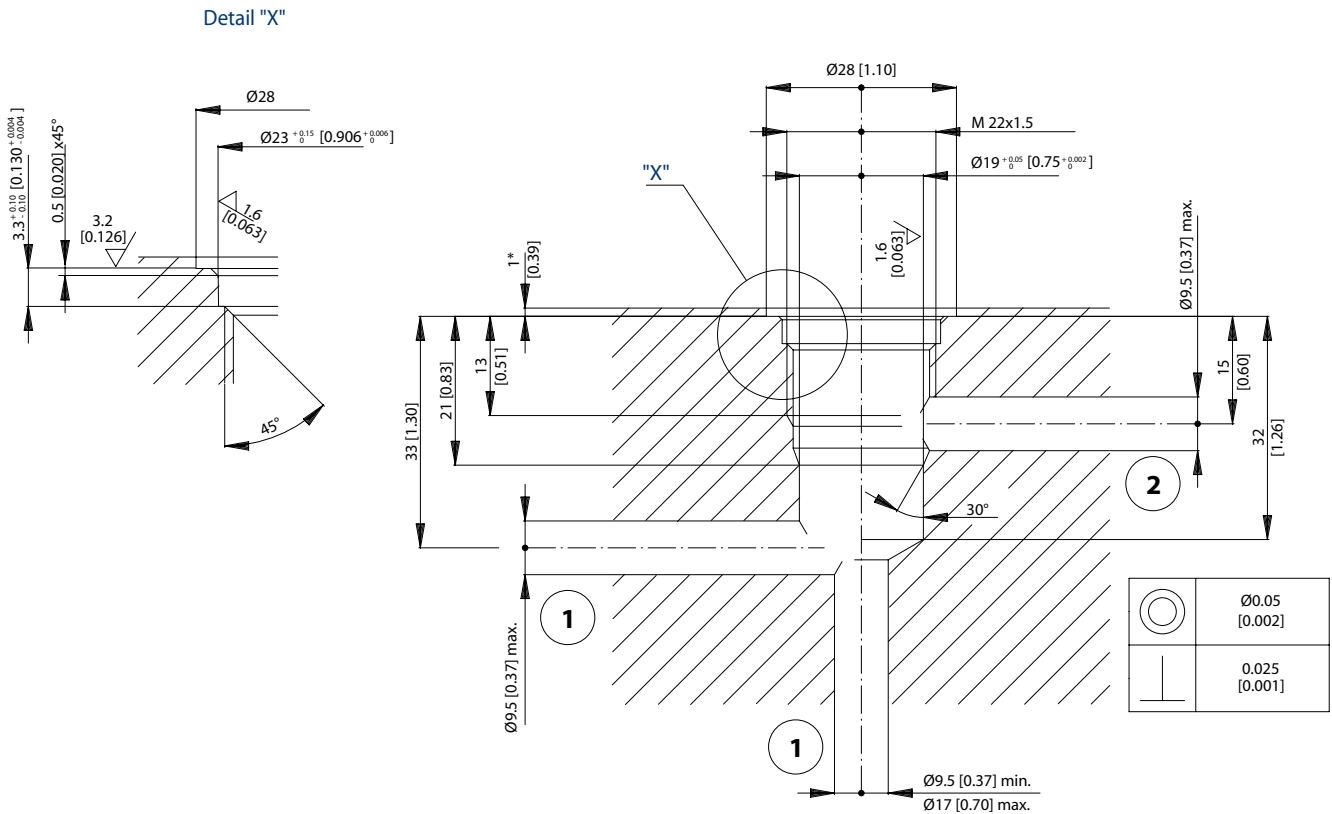

CA - Cavities
NCS06/2

Form tools

	Model code	Material number
Roughing tool	NCS-06-2-FT	11027158
Finishing Tool	NCS-06-2-RT	11027159

Housings

Order Code	Description	Ports	Page
NCS06/2-DG-1/2	Aluminum Housing	1/2 BSP	HS - 36
NCS06/2-DG-3/8	Aluminum Housing	3/8 BSP	HS - 35
NCS06/2-DG-6S	Aluminum Housing	SAE #6	HS - 35
NCS06/2-DG-8S	Aluminum Housing	SAE #8	HS - 36
NCS06/2-LG1-1/2	Aluminum Housing, Two #2 Ports	1/2 BSP	HS - 38
NCS06/2-LG1-3/8	Aluminum Housing, Two #2 Ports	3/8 BSP	HS - 39
NCS06/2-LG1-8S	Aluminum Housing, Two #2 Ports	SAE #8	HS - 38
NCS06/2-LG2-1/2	Aluminum Housing, Two #1 Ports	1/2 BSP	HS - 34
NCS06/2-LG2-3/8	Aluminum Housing, Two #1 Ports	3/8 BSP	HS - 37
NCS06/2-LG2-6S	Aluminum Housing, Two #1 Ports	SAE #6	HS - 37
NCS06/2-LG2-8S	Aluminum Housing, Two #1 Ports	SAE #8	HS - 34