



# Proportional Valves Catalog

## Proportional Directional

### PDCV05-3Z11



### OPERATION

This is a non-compensated proportional directional control valve.

### SPECIFICATIONS

<b>Rated pressure</b>	350 bar [5075 psi]
<b>Rated Flow at 10 bar [150 psi]</b>	60 l/min [16 US gal/min]
<b>Weight</b>	6.60 kg [14.60 lb]
<b>Hysteresis</b>	6% maximum
<b>Threshold current</b>	0.2 A (12 VDC coil) 0.1 A (24 VDC coil)
<b>Maximum control current</b>	1.8 A (12 VDC coil) 0.9 A (24 VDC coil)
<b>Cavity</b>	ISO D05
<b>Standard Coil</b>	PD05 23 Watt

### Theoretical performance

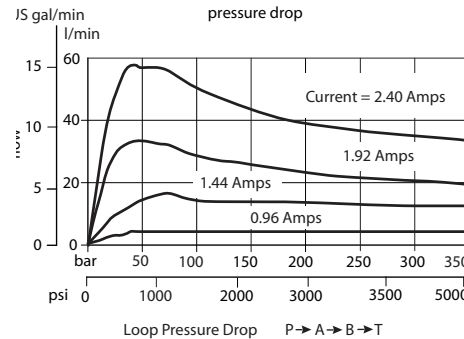
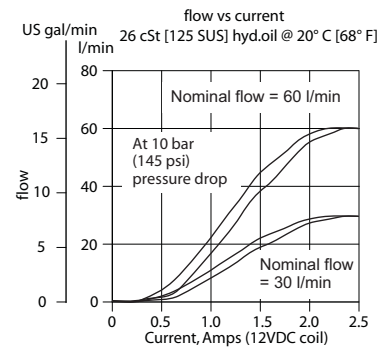

### Schematic

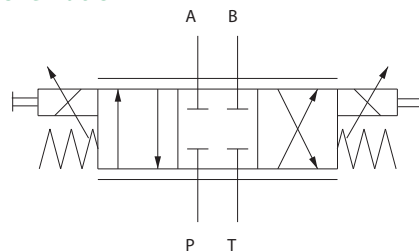

### Cross-sectional view

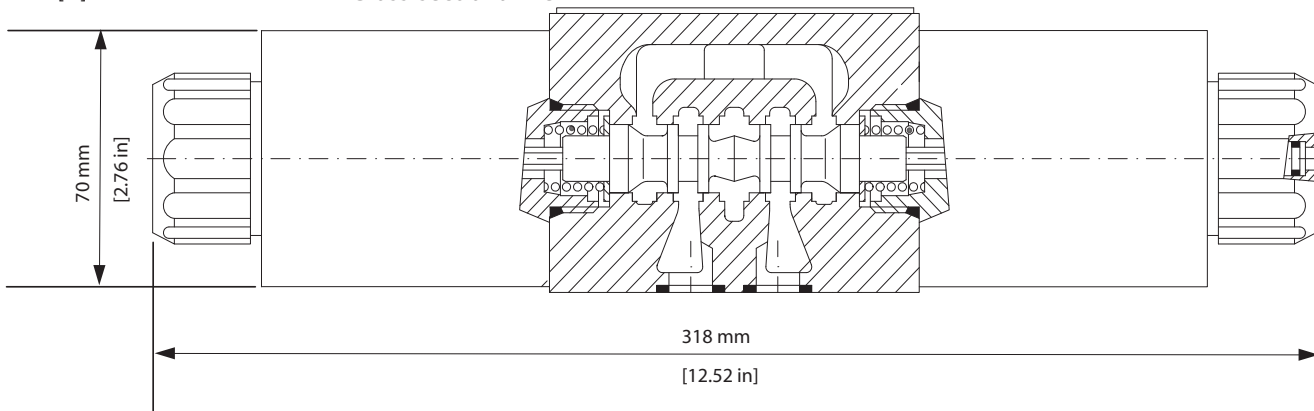

### DIMENSIONS

mm [in]

### ORDERING INFORMATION

PDCV05-3Z11/30-12-E1

#### Connector

- E1 = DIN 43650
- E8 = Lead wires
- E10 = Deutsch on leads

#### Seal kit

- B = Buna N 158-8023
- V = Viton 158-8094
- All internal seals are Viton

#### Flow rate

- 30 = 30 l/min [7.9 US gal/min]
- 60 = 60 l/min [15.8 US gal/min]

#### Voltage

- 12 = 12 VDC
- 24 = 24 VDC

#### Bolt kit

- 1/4-20 Thd 158-8095
- M6 Thd 158-8024

Proportional Valves  
PDCV03-3Z11