



OPERATION

Solenoid Valve, Spool Type, 3-Position, 4-Way, 10-size. When de-energized, the SV10-34-03 is open center, and opens flow between all four ports. When coil S1 is energized, the spool shifts to allow flow from port 3 to port 2, and from port 4 to 1. When coil S2 is energized, the spool shifts to allow flow from port 3 to port 4, and from port 2 to 1. Follow the "Operating Envelope" limits to ensure shifting of the valve during operation.



Shown with Standard Coils, Deutsch Connectors

APPLICATIONS

These spool-type valves are primarily used in mobile and industrial applications for controlling the direction of the flow in a circuit. Solenoid spool-type valves are direct acting and respond quickly to coil voltage input. Spool valves will have some leakage due to spool clearance, so if your application requires no leakage at the working port(s), apply a low leakage poppet valve(s), like PO check valve, counterbalance valve, etc., in addition to this solenoid valve. This valve can operate with an inlet pressure of 315 bar on port 3 for 400,000 cycles. Port 1 may be pressurized to 210 bar, but is not intended as inlet (Tank only).

SPECIFICATIONS

Rated pressure*	230 bar [3300 psi]**
Rated flow at 7 bar [100 psi]	25 l/min [6.6 US gal/min]
Weight	0.81 kg [1.79 lb]
Cavity	SDC10-4
Standard Coil	M16 26 Watt
Robust Coil	R16 20 Watt Robust Nut P/N 173804910 (no coil O-rings needed)

* Rated Pressure based on NFPA fatigue test standards (at 1 Million Cycles).

** See 315 bar pressure rating note on page 10.

SCHEMATIC

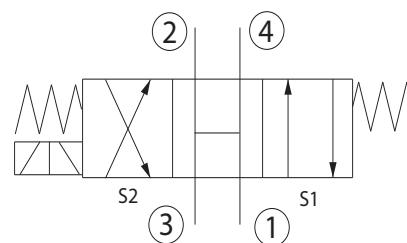

PERFORMANCE CURVES

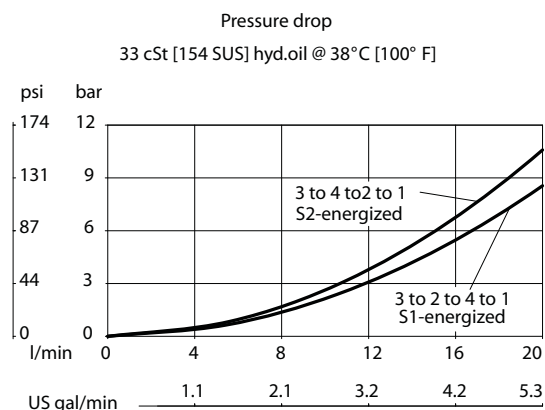

Operating envelope

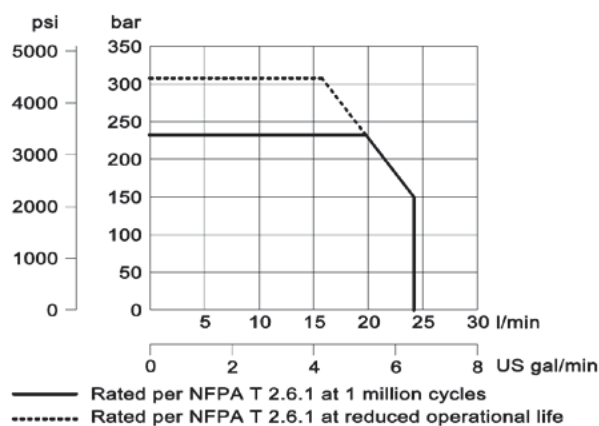



Solenoid Valves Catalog

4-Way, 3-Position Spool

SV10-34-03



DIMENSIONS

Cross-sectional view

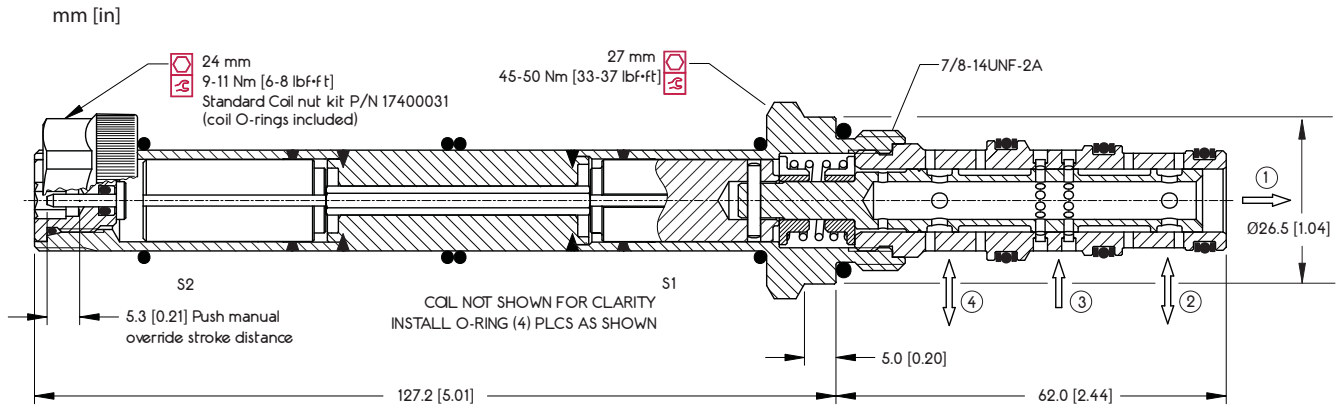

EXAMPLE CIRCUITS

Directional motor control with dual counterbalance and pressure compensation

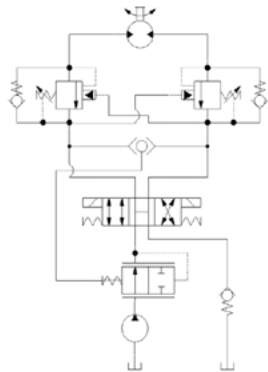

Double-acting cylinder control with single pilot-operated check.

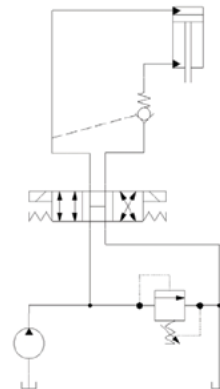

ORDERING INFORMATION

SV10 - 34 - 03 - 12D - DE - PB - B - 00

Solenoid Valve, 10 Size Cavity

34:
3 Position, 4 Way, Spool Type

03:
Schematic: Open Center

Coil Voltage	Standard Coil Code	Robust Coil Code
No Coil, with nut*	00	R00
10 VDC	10D	R10D
12 VDC	12D	R12D
20 VDC	20D	R20D
24 VDC	24D	R24D
110 VAC**	110A	-
220 VAC**	220A	-

* Standard coil – plastic nut and O-rings; R-coil – steel nut P/N 173804910 (no coil O-rings needed)
** DIN only - external rectifier needed

Coil Termination	Standard Coil Code	IP Rating	Robust Coil Code	IP Rating
No Coil	00	-	00	-
Amp Junior	AJ	IP67	-	-
Amp Junior with Diode	AJD	IP67	-	-
AMP SuperSeal 1.5	AS	IP67	AS	IP69K
AMP SuperSeal with Diode	ASD	IP67	ASDB	IP69K
Deutsch	DE	IP67	DE	IP69K
Deutsch with Diode	DED	IP67	DEDB	IP69K
Flying Leads	FL	IP65	FL	IP69K
Flying Leads with Diode	FLD	IP65	FLDB	IP69K
DIN 43650	DN	IP65	-	-
Metri-Pack 150 Type 2	-	-	M3	IP69K
Metri-Pack 150 with Diode	-	-	M3DB	IP69K

Code	Body and Ports	Body Nomenclature
00	Cartridge Only	No Body
6S	#6 SAE, AL	CP10-4-6S
8S	#8 SAE, AL	CP10-4-8S
S8S	#8 SAE, Steel	CP10-4-S8S
L3B	3/8 BSP, AL	SDC10-4-L3B
L4B	1/2 BSP, AL	SDC10-4-L4B
S4B	1/2 BSP, Steel	CP10-4-S4B

Seal Code	Material	Seal Kits
B	Buna-N	354001919
V	Viton	354002019

Code	Manual Override
Omit	Push Pin (Standard)
PB	Push Button
SPS	Screw Style (Push-Type Valve)
OPS	Push Pin Nut for Protection & Actuation
PAT	Push and Twist