



OPERATION

This is a direct acting, 3-position, 4-way spool type solenoid valve. When de-energized, the SV10-34-14 allows flow from port 3 to 2 and from port 4 to 1. When coil S1 is energized, the spool shifts to the float position, allowing flow from port 2 and 4 to port 1, while blocking flow to port 3. When coil S2 is energized, the spool shifts to allow flow from port 2 to 1, and from port 4 to 3. The SV10-34-14 comes standard with a one-direction, push-pin manual override. When the manual override is pushed, the spool shifts following the logic of energizing S2. The SV10 uses a 10 size cavity and an optional 500 micron filter is available.



Shown with Standard Coils,
Deutsch Connectors

APPLICATIONS

These valves are typically used for directional control for motor or cylinder functions, to run forward, reverse, or float free. Applications for this schematic include street sweepers (broom height control) and windrower header height. Use a pressure reducing valve before the "P" port to manage the force. This valve can also be applied to a reversing fan drive with a pressure regulated variable pump. The schematic allows the fan to shift smoothly from forward to reverse. Additionally, if the fan drive loses power, the spool shifts to the center position and the fan turns in the forward direction. This valve can operate with an inlet pressure of 315 bar on port 3 for 300,000 cycles. Port 1 may be pressurized to 150 bar, but is not intended for use as inlet (Tank only).



Shown with Robust Coils,
Deutsch Connectors

SPECIFICATIONS

Rated Pressure*	230 bar [3330 psi]
Maximum Rated Flow at 7 bar [100 psi]	17 l/min [4.5 US gal/min]
Weight including coil	0.81 kg [1.79 lbs]
Cavity	SDC10-4
Standard Coil	M16 26 Watt
Robust Coil	R16 20 Watt Robust Nut P/N 173804910 (no coil O-rings needed)

* Rated Pressure based on NFPA fatigue test standards (at 1 Million Cycles).

** See 315 bar pressure rating note on page 10.

SCHEMATIC

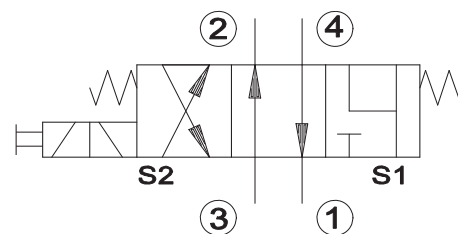

PERFORMANCE CURVES

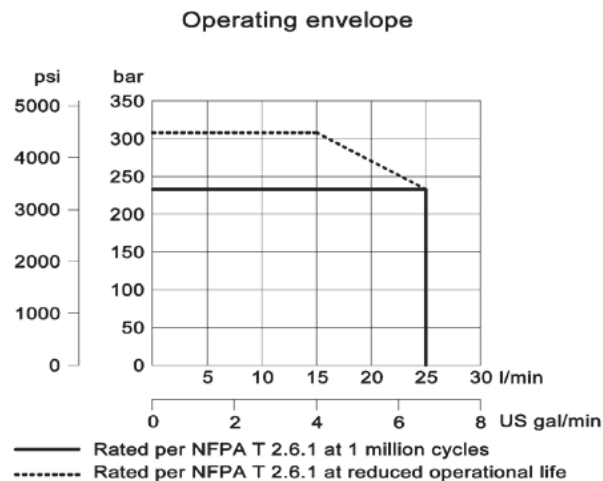
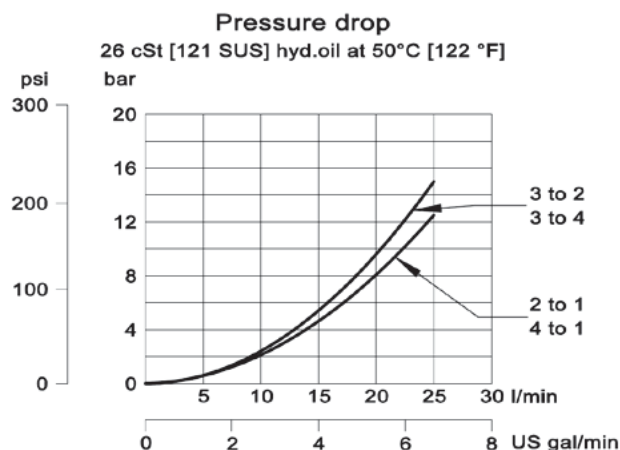



DIMENSIONS

mm [in]

Cross-sectional view

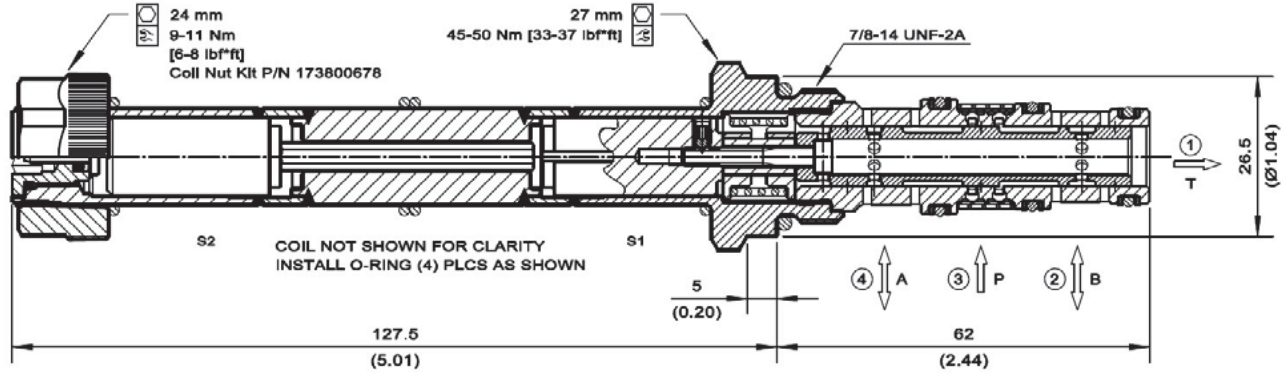

EXAMPLE CIRCUITS

Height Control with Float Option

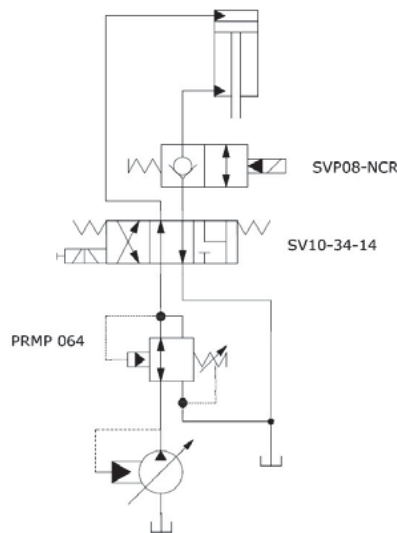

ORDERING INFORMATION

SV10 - 34 - 14 - 12D - DE - PB - B - F - 00

Solenoid Valve, 10 Size Cavity

34:
3 Position, 4 Way, Spool Type

14:
Schematic: Raise, Lower, Float

Coil Voltage	Standard Coil Code	Robust Coil Code
No Coil, with nut*	00	R00
10 VDC	10D	R10D
12 VDC	12D	R12D
20 VDC	20D	R20D
24 VDC	24D	R24D
110 VAC**	110A	-
220 VAC**	220A	-

* Standard coil – plastic nut and O-rings; R-coil – steel nut P/N 173804910 (no coil O-rings needed)
** DIN only - external rectifier needed

Coil Termination	Standard Coil Code	IP Rating	Robust Coil Code	IP Rating
No Coil	00	-	00	-
Amp Junior	AJ	IP67	-	-
Amp Junior with Diode	AJD	IP67	-	-
AMP SuperSeal 1.5	AS	IP67	AS	IP69K
AMP SuperSeal with Diode	ASD	IP67	ASDB	IP69K
Deutsch	DE	IP67	DE	IP69K
Deutsch with Diode	DED	IP67	DEDB	IP69K
Flying Leads	FL	IP65	FL	IP69K
Flying Leads with Diode	FLD	IP65	FLDB	IP69K
DIN 43650	DN	IP65	-	-
Metri-Pack 150 Type 2	-	-	M3	IP69K
Metri-Pack 150 with Diode	-	-	M3DB	IP69K

Code	Body and Ports	Body Nomenclature
00	Cartridge Only	No Body
6S	#6 SAE, AL	CP10-4-6S
8S	#8 SAE, AL	CP10-4-8S
S8S	#8 SAE, Steel	CP10-4-S8S
L3B	3/8 BSP, AL	SDC10-4-L3B
L4B	1/2 BSP, AL	SDC10-4-L4B
S4B	1/2 BSP, Steel	CP10-4-S4B

Seal Code	Material	Seal Kits
B	Buna-N	354001919
V	Viton	354002019

Code	Manual Override
Omit	Push Pin (Standard)
PB	Push Button
SPS	Screw Style (Push-Type Valve)
OPS	Push Pin Nut for Protection & Actuation
PAT	Push and Twist

No Filter
Filter 500 µm

Omit
F