

Dimensions

mm [in]

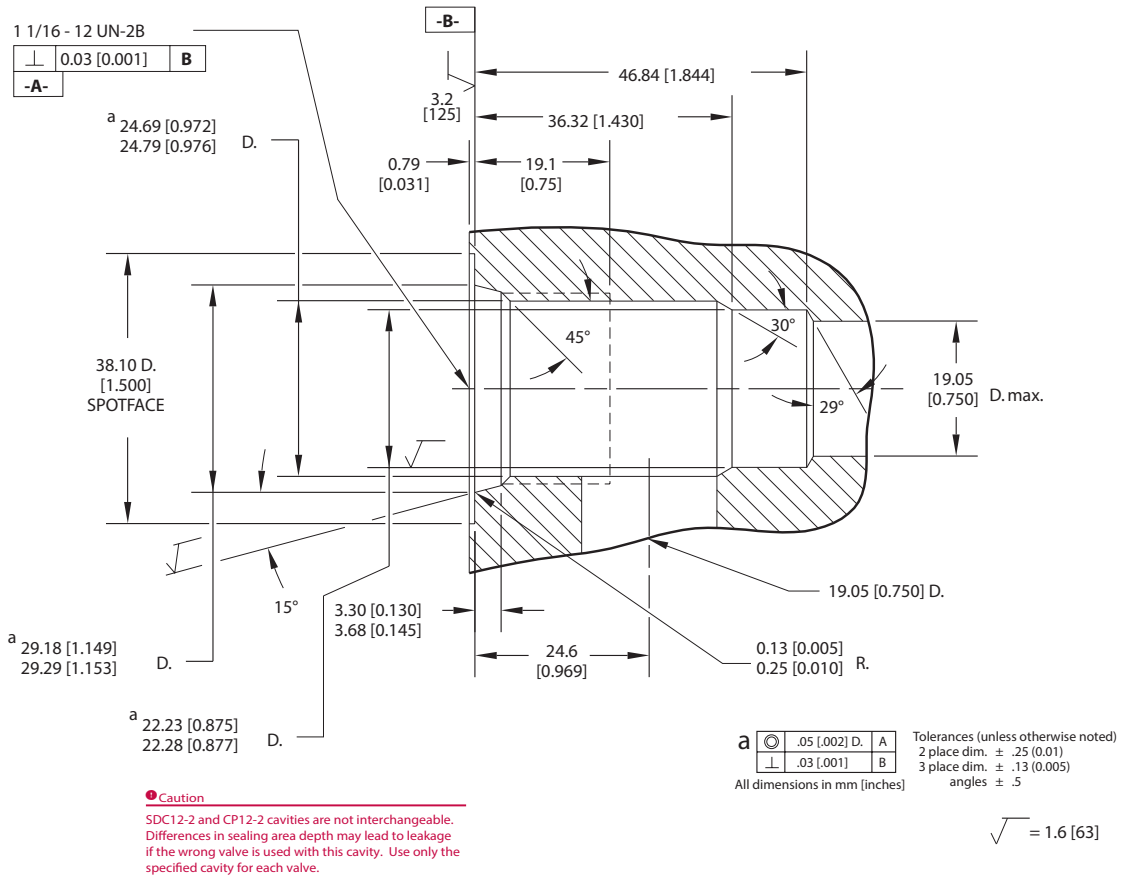

Form tools

	Model code	Material number
Roughing tool	CP-12-2-RT	310022
Finishing Tool	CP-12-2-FT	310005

Housings

Order Code	Description	Ports	Page
CP12-2-10S	Aluminum Housing	SAE #10	HS - 12
CP12-2-12S	Aluminum Housing	SAE #12	HS - 12
CP12-2-S10S	Steel Housing	SAE #10	HS - 12
CP12-2-S12S	Steel Housing	SAE #12	HS - 12
CP12-2-4B	Aluminum housing	1/2 BSP	HS - 12
CP12-2-6B	Aluminum housing	3/4 BSP	HS - 12