

Dimensions

mm [in]

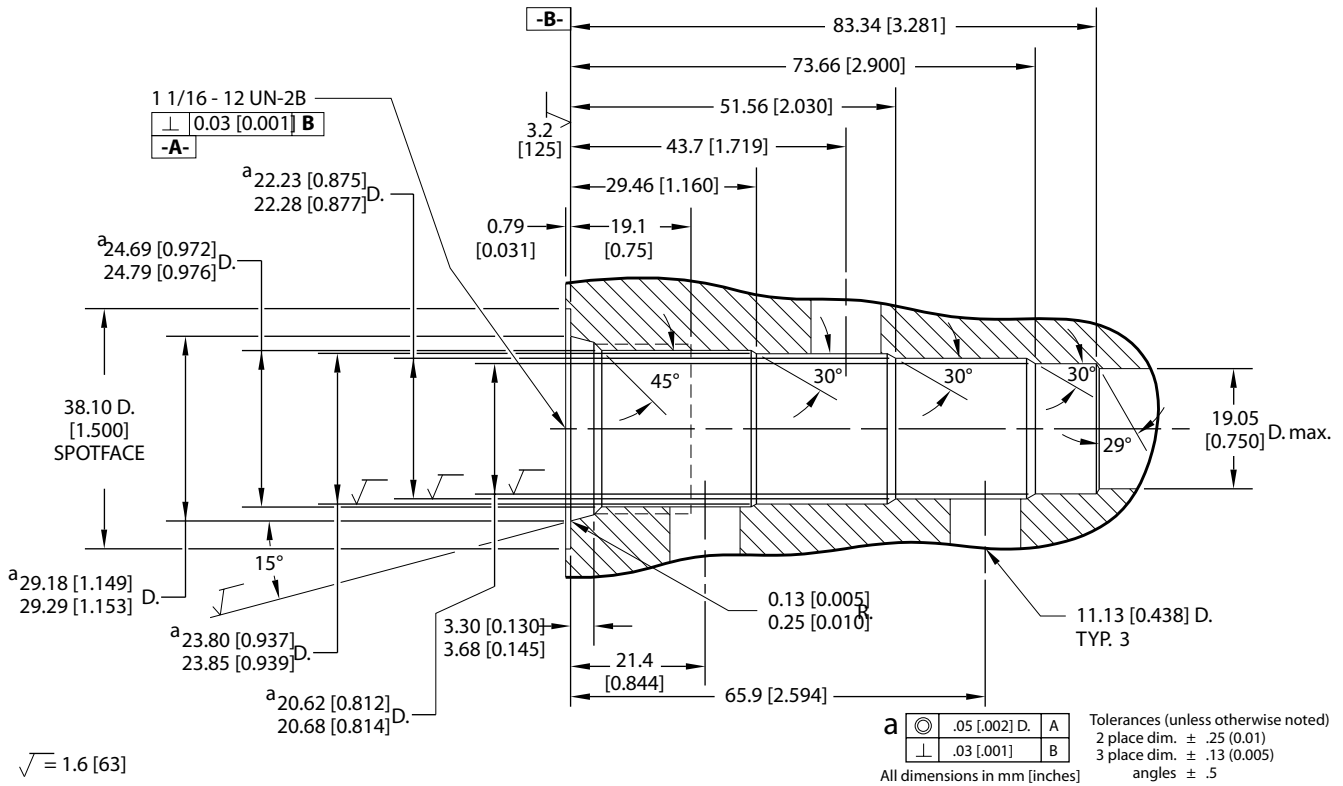

CA - Cavities
CP12-4

Form tools

	Model code	Material number
Finishing tool	CP-12-4-FT	11027090
Roughing tool	CP-12-4-RT	11027091

Housings

Order Code	Description	Ports	Page
CP12-4-10S	Aluminum Housing	SAE #10	HS - 17
CP12-4-10S/4S	Aluminum Housing, Pilot at Port #1	SAE #10, #4	HS - 17
CP12-4-10S-X1	Aluminum Housing, No Port #1	SAE #10	HS - 17
CP12-4-3B	Aluminum Housing	3/8 BSP	HS - 17
CP12-4-3B-X1	Aluminum Housing, No Port #1	3/8 BSP	HS - 17
CP12-4-4B	Aluminum Housing	1/2 BSP	HS - 17
CP12-4-4B-X1	Aluminum Housing, No Port #1	1/2 BSP	HS - 17
CP12-4-8S	Aluminum Housing	SAE #8	HS - 17
CP12-4-8S/4S	Aluminum Housing, Pilot at Port #1	SAE #10, #4	HS - 17
CP12-4-8S-X1	Aluminum Housing, No Port #1	SAE #8	HS - 17