

Dimensions

mm [in]

TOLERANCES UNLESS OTHERWISE SPECIFIED

Diameter and Lengths:  
if < 18mm ± 0.1 [0.004]  
Angles ± 2°

⊙	∅0.05 [0.002]	A
⊥	0.025 [0.001]	B

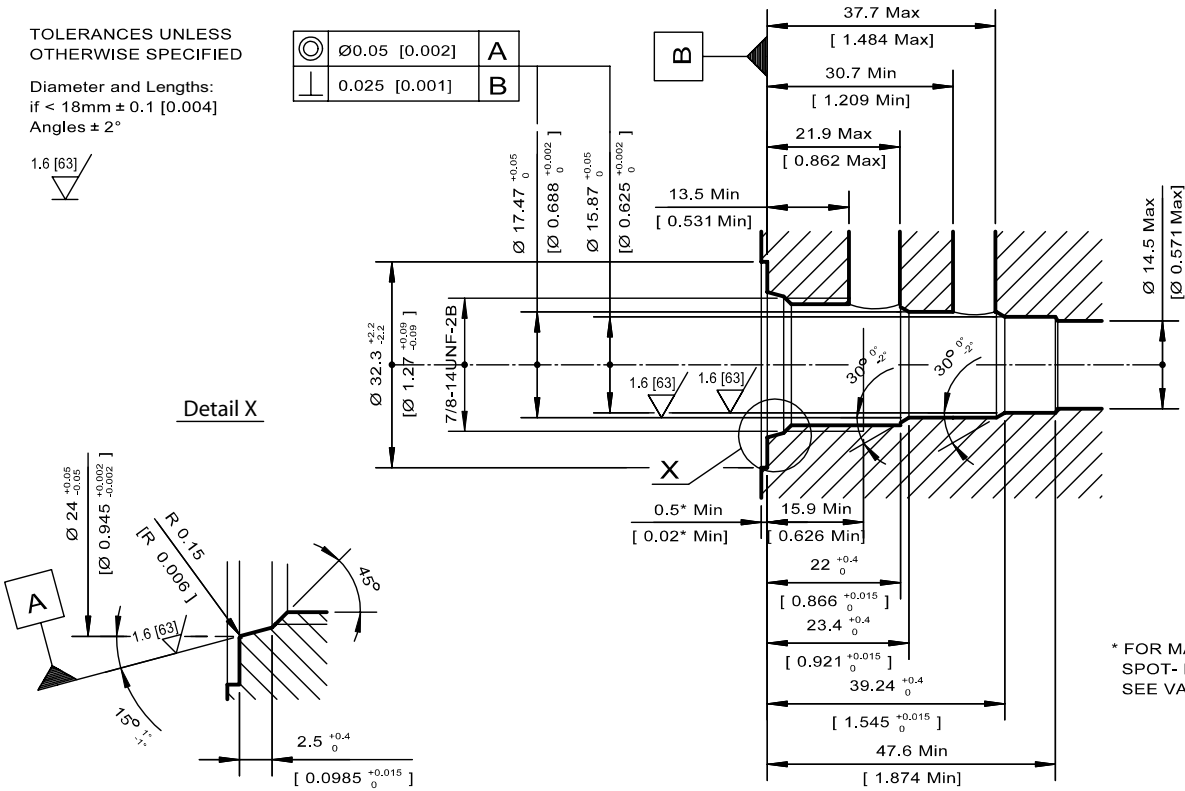

Detail X

\* FOR MAX DEPTH OF SPOT- FACE SEE VALVE DRAWINGS

CA - Cavities  
SDC10-3

Form tools

	Model code	Material number
<b>Finishing tool</b>	SDC-10-3-FT	11027188
<b>Roughing tool</b>	SDC-10-3-RT	11027119

Housings

Order Code	Description	Ports	Page
CP10-3-6S	Aluminum Housing	SAE #6	HS - 83
CP10-3-8S	Aluminum Housing	SAE #8	HS - 83
CP10-3-S6S	Steel Housing	SAE #6	HS - 83
CP10-3-S8S	Steel Housing	SAE #8	HS - 83
SDC10-3-SE-3B	Aluminum Housing	3/8 BSP	HS - 87
SDC10-3-SE-4B	Aluminum Housing	1/2 BSP	HS - 86
SDC10-3-SI-3B	Aluminum Housing, Two #1 Ports	3/8 BSP	HS - 84
SDC10-3-SI-4B	Aluminum Housing, Two #1 Ports	1/2 BSP	HS - 85