

White Paper

# Fundamentals of autonomous vehicles with **PLUS+1® GUIDE**



*Abstract* - The current autonomous machine revolution has the potential to advance autonomous vehicles, specifically for off-highway and agricultural vehicles. Danfoss Power Solutions is making it easier than ever to integrate these technologies into our customers' machines. This paper demonstrates the fundamentals behind our PLUS+1® GUIDE Autonomous library and can help speed up vehicle integration.

## I. Introduction

Autonomous vehicles and driver assistance systems have experienced widespread proliferation in the automotive market. While the required sensors and processors were initially designed for on-highway applications, many of the algorithms and knowledge can be transferred to the off-highway market. Danfoss continues to develop and integrate new autonomous vehicle technologies into its existing PLUS+1® platform. The DAVIS vehicle (Fig. 1) is one of several test platforms used at our Application Development Centers for testing and integration of new sensors and technologies.

Each of the testing and development vehicles used by Danfoss

started as stock machines which were then modified to provide autonomous functionality. With the addition of off-the-shelf sensors and tight integration with Danfoss microcontrollers, these vehicles were quickly adapted to navigate environments without an operator.



Fig. 1 - The DAVIS Test Vehicle

The core functionality required to retrofit a vehicle and add autonomous capabilities is comprised of three subsystems: localization, navigation, and perception. The implementation details for each of these subsystems is outlined in the following sections. Additionally, the required sensors for autonomy are outlined in Section II.

## II. Sensors

There are a wide variety of sensors available from multiple vendors for use in autonomous systems.

Inertial Measurement Units (IMU) provide a world referenced estimate of vehicle heading along with instantaneous acceleration angular velocity estimates along each of the 3 primary direction vectors (Fig. 2).

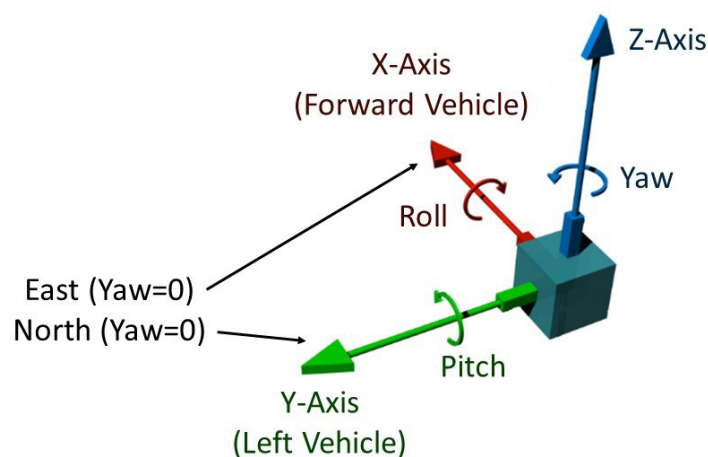

Fig. 2 - 3 Dimensional Orientation Sensors

Multiple manufacturers provide IMU solutions that support CAN communication and that integrate well with PLUS+1® GUIDE. There are also multiple packaging options for IP67 rated requirements.

Global Positioning Systems (GPS) are now a ubiquitous technology found in systems ranging from cell phones to consumer vehicles. The market has seen the recent availability of cost-effective Real Time Kinematic (RTK) GPS solutions which has enabled the use of GPS for high accuracy localization applications. RTK positioning systems enhance the accuracy of traditional GPS satellite data by measuring phase variations in the signal to produce correction data. This correction data is computed at a stationary base-unit and is transmitted wirelessly to the mobile GPS receiver (Fig. 3).

There are a variety of RTK GPS units which provide CAN-based communication and can integrate with PLUS+1® control applications.

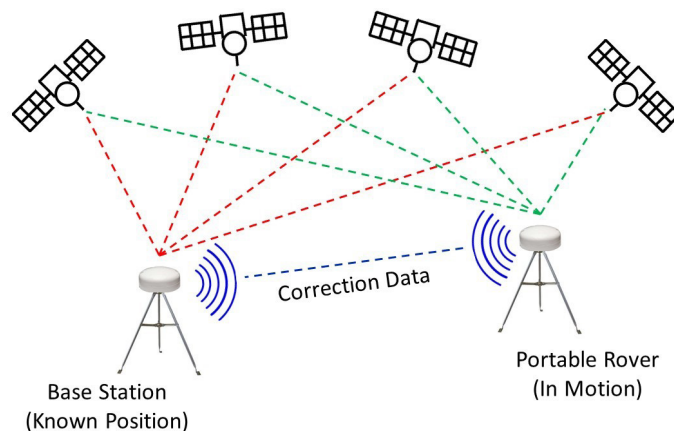

Fig. 3 - RTK GPS Setup

The primary consideration for RTK units is the required spatial resolution and which Global Navigation Satellite System (GNSS) constellations are supported. The GPS blocks within PLUS+1® GUIDE support both the NMEA 2000 and SAE J1939 standard GPS CAN message structures.

Wheel speed sensors and steering angle sensors are typically integrated into localization algorithms for autonomous functionality. These sensors allow for an estimate of the vehicle's position and velocity known as wheel odometry. Wheel odometry position estimates are based on the cumulative distance traveled by the wheels. Many of the motors available from Danfoss incorporate Pulse Pickup Units (PPU) for sensing wheel speed. The PVED-CLS actuator from Danfoss for electrohydraulic steering solutions is an intelligent steering sub-system which integrates safety functionality [1].

A wide variety of sensors are available for obstacle detection and avoidance. Laser based (LiDAR) systems are commonly used in robotic platforms but typically require Ethernet, or other high-bandwidth communication mediums. Radar system are well suited for a variety of applications and are robust to variations in lighting and weather. Multiple vendors produce radar units capable of sensing multiple objects and provide CAN communication (Fig. 4).

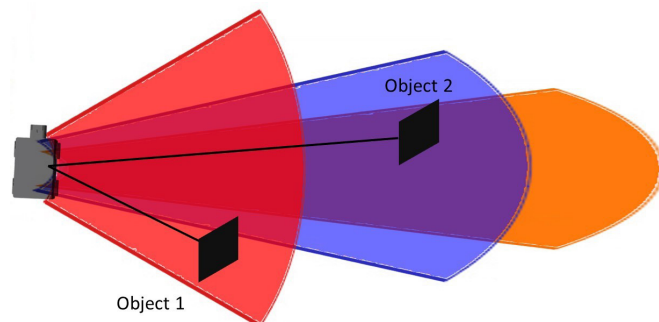

Fig. 4 - Multi-Channel Radar Sensing

Radar and LiDAR systems are utilized for path planning and safe vehicle operation to determine optimal motion plans and avoid collisions. Ultrasonic sensors can also be used for object detection in close-range and single channel applications. Typical ultrasonic sensors have a conical detection zone and provide a scalar distance value to the nearest object. This makes ultrasonic sensors useful for emergency braking and safety curtain scenarios.

### III. Localization

A fundamental component required for autonomy is localization. Localization or position sensing is a set of algorithms used to produce a constant and reliable estimate of a vehicle's location in the world.

A common approach for localization is the Extended Kalman Filter (EKF) algorithm [2]. The EKF is a state estimation algorithm for non-linear systems which allows the fusion of multiple sensor readings. In a typical scenario a vehicle may contain a GPS unit, an IMU, and wheel odometry sensors. The EKF provides a method to combine data from each of those sensors to produce an improved estimate of the vehicle's position and orientation over time.

The EKF algorithm relies on a series of propagate and update steps wherein the vehicle's state is estimated via a kinematic model and periodically corrected when new sensor readings are available. Both steps adjust what is known as the state matrix 'X'. The state matrix for a vehicle operating in two dimensions can be expressed according to Eq. 1 where  $x, y, \theta$  refer to the vehicles relative Cartesian coordinates and orientation along with subsequent derivatives.

$$X = [x, y, \theta, \dot{x}, \dot{y}, \dot{\theta}, \ddot{x}, \ddot{y}]^T \quad (1)$$

Localization with an EKF requires sensor data to be formatted correctly so it adheres to standard conventions. For instance, raw GPS data is conventionally reported in latitude and longitude as measured from the equator and the prime meridian. When introducing this data to the state matrix it must first be transformed into Cartesian units (typically meters). This transformation is based on the Universal Transverse Mercator (UTM) projection. UTM data is expressed in terms of X (east, meters) and Y (north, meters) in specially defined grid regions around the globe.

As an example, the Danfoss Application Development Center in Nordborg, Denmark is located at  $55.031657^\circ, 9.818984^\circ$  which corresponds to a UTM location of  $x = 552347.3m, y = 6098620.8m$ . For the purpose of vehicle localization, the initial UTM coordinate is generally assumed to be the vehicle origin with all subsequent UTM readings being relative to that location. In this way a vehicle moving East reports an increasing X position, while heading North it reports an increasing Y position.

The wheel odometry data is also formatted to adhere to the autonomous vehicle standard (Fig. 5). This requires that when the vehicle reports its velocity, a positive propel value is forward along the vehicle's body and a positive angular velocity corresponds to a counter-clockwise rotation.

Finally, the IMU data is formatted so the reported heading (orientation) is zero when the vehicle is facing East so that the orientation aligns with the GPS position estimates. The linear acceleration estimate ( $\ddot{x}$ ) is similarly oriented such that a positive acceleration value is aligned with the forward axis of the vehicle.

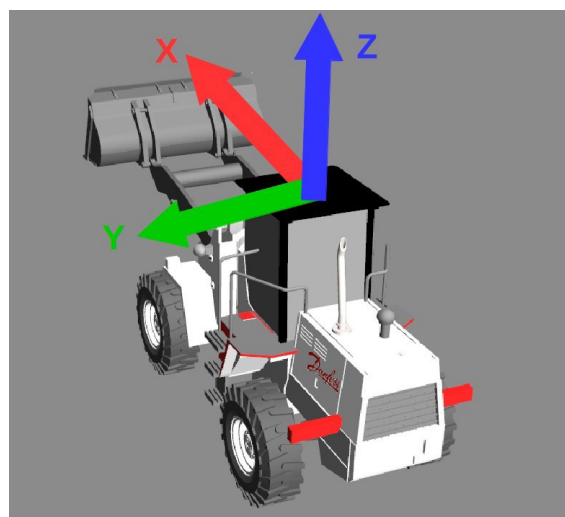

Fig. 5 - Standard Vehicle Coordinate Frame

### IV. Navigation

Once the localization subsystem has provided information regarding the vehicle's current position, the next step in the autonomous pipeline is to determine a path to reach a goal location without colliding with obstacles. Typically, a path will consist of a series of evenly spaced temporary goals or 'waypoints' that can be followed. Using these waypoints, a path following algorithm can be used to steer the vehicle and remain on the path.

Path planning typically consists of two parts: computing a high-level global plan from point 'A' to point 'B' followed by a low-level 'local planner' for controlling the vehicle. A simple global plan algorithm consists of taking a straight line from the vehicle's current position to the goal position. This straight line is then broken into a series of waypoints  $p_i$  for the local planner to follow (Fig. 6).



Fig. 6 - Basic Global Plan (Yellow) With Waypoints (Red)

More complex global plans can be computed in the presence of known obstacles. A common algorithm known as "A\*" can be used to determine optimal paths around obstacles [3]. In this case obstacles are represented in a costmap format which consists of a matrix of values where obstacles, unknown regions, and free regions are all represented by different cost values. The A\* algorithm identifies a path through the costmap to the goal which results in the lowest cost (i.e. shortest route without encountering an obstacle). This method considers all option costs at a given location and continues to move in the direction of the lowest cost (Fig. 7).

X	X	X	X	X	X	X	X	X
X		6	6	X				X
X	6	A	4	X		B		X
X		X	6	X	14	12	14	X
X		10	8	X	14	12	14	X
X		12	10	X	12	12	14	X
X		14	12	12	12	12	14	X
X			14	14	14	14	14	X
X	X	X	X	X	X	X	X	X

Fig. 7 - A\* Path Planning with Optimal Path Costs (blue) & Alternate Costs (red)

Once a global plan has been identified, a path follower is used to command the vehicle steering and velocity to follow the global plan as closely as possible. A common path following algorithm is known as Pure Pursuit [4].

In a typical pure pursuit implementation, the vehicle's current position is used to identify the closest waypoints in the path.

These waypoints are used to determine a line segment in space. This segment, along with a desired 'lookahead' distance (L), is used to determine an optimal 'lookahead' point on the segment to drive towards (Fig. 8).

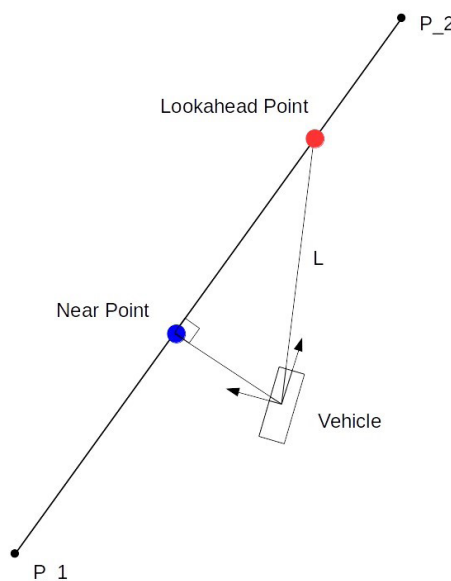

Fig. 7 - Basic Pure Pursuit Diagram

Given the coordinates of this lookahead point relative to the vehicle coordinate frame  $(x_i, y_i)$ , the required steering angle can be computed according to equations 2-4. Where WB is the vehicle's wheel base and  $\gamma$  is the resultant steering angle.

$$D = \sqrt{x_i^2 + y_i^2} \tag{2}$$

$$R = \frac{D^2}{y_i} \tag{3}$$

$$\gamma = \tan^{-1}\left(\frac{WB}{R}\right) \tag{4}$$

### V. Conclusion

Autonomous technology is rapidly becoming an integral component in modern off-highway and agriculture vehicles. Through the PLUS+1® GUIDE platform, Danfoss provides the fundamental building blocks for autonomous machines. This allows machine manufacturers to focus on the niche technology required for their application.

Variations on the path following and global path planning algorithms are core components of the Autonomous Control Library for PLUS+1® GUIDE. This library also contains a variety of localization blocks for integrating various sensing technologies.

## References

1. D.P. Solutions. (2018) PVED\_CLS [Online].  
<https://www.danfoss.com/en/products/steering/dps/steeringcomponents-and-systems/electrohydraulic-steering/pved-cls/>
2. L. Jetto, S. Longhi, and G. Venturini, "Development and experimental validation of an adaptive extended kalman filter for the localization of mobile robots," IEEE Transactions on Robotics and Automation, vol. 15, no. 2, pp. 219–229, 1999.
3. P. E. Hart, N. J. Nilsson, and B. Raphael, "A formal basis for the heuristic determination of minimum cost paths," IEEE transactions on Systems Science and Cybernetics, vol. 4, no. 2, pp. 100–107, 1968.
4. R. C. Coulter, "Implementation of the pure pursuit path tracking algorithm," Carnegie-Mellon UNIV Pittsburgh PA Robotics INST, Tech. Rep., 1992.