



# KIT SIE CONVERSION

100514, 100515, 100516, & 100517



**Installation and servicing of Danfoss Turbocor® compressors by qualified and product trained personnel only. Follow these instructions and sound refrigeration/electrical/servicing practices relating to installation, commissioning, maintenance and service.**

<p>Consult the appropriate Danfoss Turbocor Compressors Inc. (DTC) Service Manual on <a href="http://turbocor.danfoss.com">turbocor.danfoss.com</a> for detailed service instructions.</p>	<p><b>Never power compressor without covers in place and secured.</b></p> <p><b>Removing the mains input cover will expose you to a voltage hazard of up to 575V. Ensure the mains input power is off and locked out before removing cover.</b></p> <p><b>Before removing top cover, wait at least 20 minutes after isolating AC power to allow the high voltage capacitors to discharge.</b></p>	<p>Always wear appropriately rated safety equipment when working around equipment and/or components energized with high voltage.</p> <p><b>This equipment contains hazardous voltages that can cause serious injury or death.</b></p>	<p><b>Recover all refrigerant from compressor in accordance with local codes and ensure pressure is fully vented before the removal of refrigerant containing components.</b></p>
--	---	---	---

## 1 - Introduction

SEMI-INTEGRATED ELECTRONICS (SIE) CONVERSION removal and installation.

## 2 - Suggested Tools:

The following tools are suggested:

- Philips screwdriver/bit
- Hex/Torx bit

## 3 - SIE Removal:

### Compressor Controller - Removal

1. Pull the Compressor Controller module out of its slot.

**NOTE:** Refer to the Service Manual for proper electrostatic discharge (ESD) handling of electronic components.

### Bearing Motor Compressor Control (BMCC) - Removal

2. Pull the BMCC module out of its slot.

### Bearing PWM Amplifier – Removal

1. Carefully withdraw the PWM cluster blocks from the Bearing Power Feedthroughs on the front and rear radial bearings. Remove the cluster blocks squarely by hand to prevent damage to the connector pins. Refer to Figure 1.

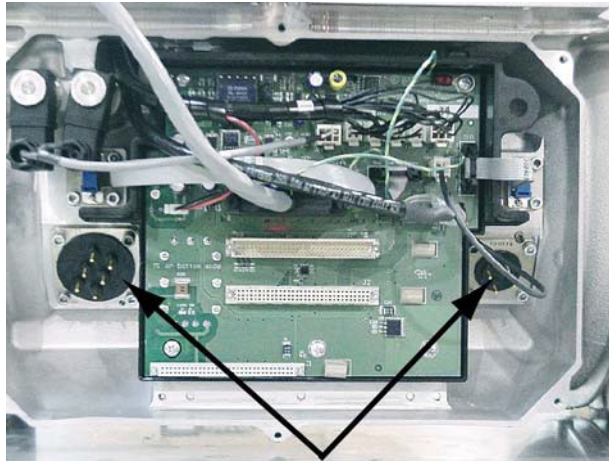

Figure 1 - Bearing Power Feed Through

2. Remove the three (3) screws that secure the heat sink of the PWM Amplifier module to the main compressor housing. Refer to Figure 2.



Figure 2 - Removing the PWM Amplifier

3. Pull the PWM Amplifier module out of its slot and store it in an antistatic location. The PWM will be re-installed with the fully integrated electronics (FIE) components.

### Backplane – Removal

1. Disconnect all connectors from the Backplane.
2. Remove the screws (including the frame ground screw at bottom right) that secure the Backplane to the service-side housing. Refer to Figure 3.

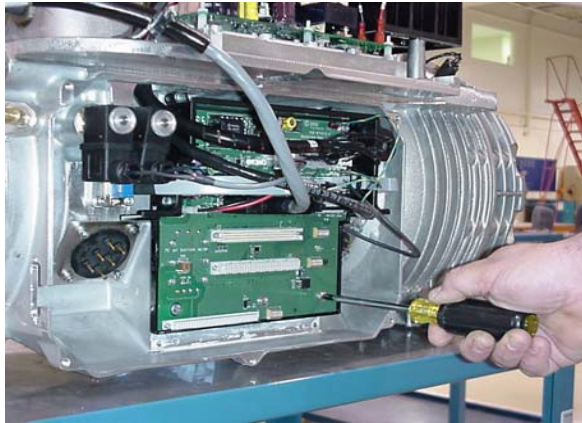

Figure 3 - Removing the Backplane Frame Ground Screw

3. Remove the six (6) small screws that secure the Backplane's DC-DC Converter heat sink to the main compressor housing.
4. Withdraw the Backplane from the service-side housing.

#### **Soft Start Module - Removal**

1. Disconnect the cable connectors from the Soft Start module.
2. Remove the Soft Start ground cable from the compressor ground post.
3. Remove the four (4) screws that secure the mounting bracket.
4. Remove the module.

#### **High-voltage DC-DC Converter -Removal**

1. Remove the five (5) spade lugs (+250V, -250V, mid-bus, +800V, -800V) from the module.
2. Using a hex bit, remove the screws that secure the DC/DC Converter heat sink to the Inverter base plate.
3. Remove the DC/DC.
4. Disconnect the spade lugs from the motor thermistor terminals and remove the compressor cable through the cable passage.

#### **Soft Start Wiring Harness Removal**

1. Disconnect the ring terminals labeled L1, L2, and L3 from the AC bus bars.
2. Disconnect the -DC ring terminal from the -DC bus bar by removing the attaching hardware.
3. Disconnect the +DC ring terminal from the +DC bus bar by removing the attaching hardware.
4. Disconnect the mid bus spade lug from the DC Capacitor mid bus bar.
5. Disconnect the SCR cables from the SCR gates.

#### **Chiller Interface Cable & Board Removal**

1. Disconnect the Chiller Interface cable from the Chiller Interface board.
2. Remove the Chiller Interface board from its location (application dependent).
3. Remove the Chiller Interface cable from its location (application dependent).

---

#### 4 - FIE Installation:

##### **Soft Start & SCR Wiring Harness Installation**

1. Connect the ring terminals labeled L1, L2, and L3 to the corresponding AC bus bars.
2. Connect the -DC ring terminals to the -DC bus bar. See Figure 4.
3. Connect the +DC ring terminal to the +DC bus bar. See Figure 4.
4. Connect the FIE SCR cable to the SCR gates.

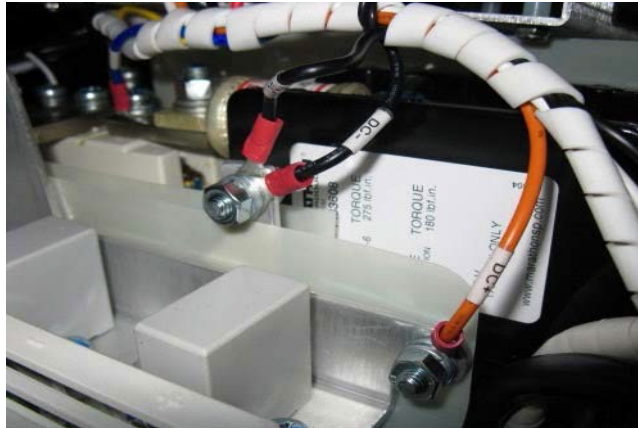

Figure 4 - Soft Start Harness to DC bus

### Compressor Cable Installation

1. Pull the compressor cable through the cable passage with the motor terminal spade lugs on the top side.
2. Connect the motor terminal spade lugs to the motor thermistor spade connectors.

**NOTE:** There are three types of cable passages that may be found on a compressor: Back Passage, Double Passage and Front Passage. See Figures 5, 6, and 7 for an illustration of the differences.

- Kits C-600 and below used Back Passage Housing
- Kits C-600 and above used Double Passage Housing
- 2011 – current, use Front Passage Only Housing

Back Passage

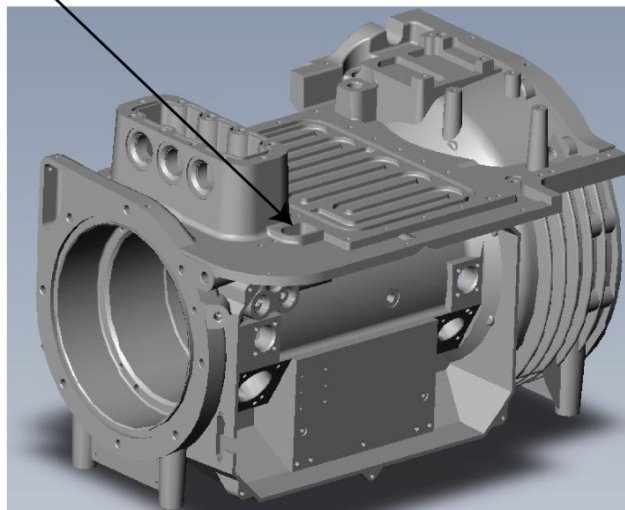

Figure 5 - Back Passage Housing

In the Back Passage Housing, the cable passage is found on the back (end bell side) of the compressor. This was used in very early models of the DTC compressor, C-600 and below.

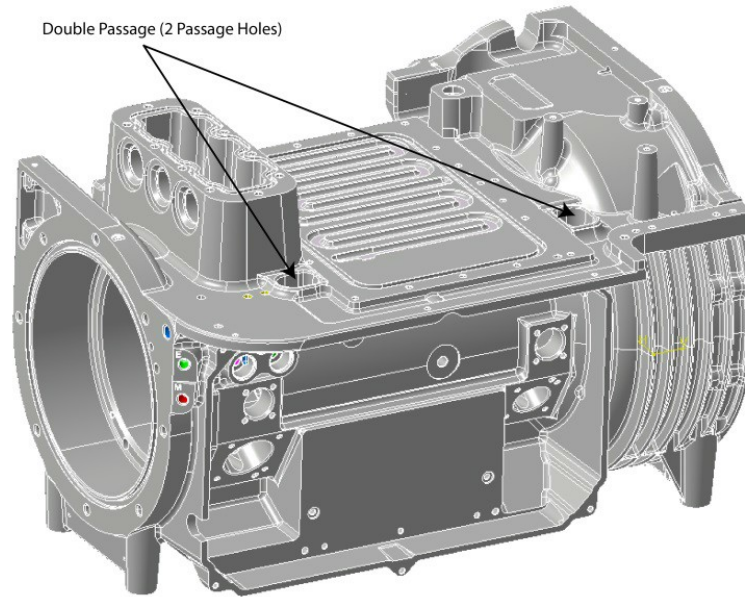

Figure 6 - Double Passage Housing

In the Double Passage Housing, the cable passage is found on both ends of the compressor. This was used in serial numbers C600 and above (until 2011 when the Front Passage Housing was introduced).

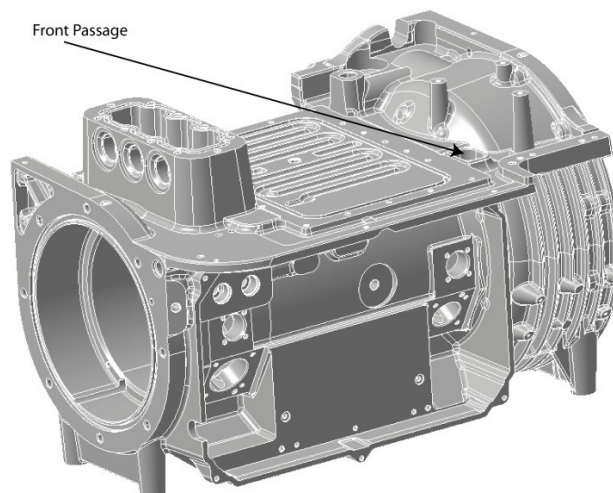

Figure 7 - Front Passage Housing

Beginning in 2011, the Front Passage was used and is still currently being used in all DTC compressors.

#### **DC/DC Installation**

1. Pre-set the DC/DC screws closest to the Inverter in the Inverter plate.
2. Apply heat conductive paste to the underside of the DC/DC heat sink plate.
3. Slide the DC/DC under the screws pre-set in the Inverter plate.
4. Insert the front screws and tighten the screws that secure the DC/DC to the Inverter plate.
5. Plug in all connectors to the DC/DC Converter.

#### **Soft Start Installation**

1. Place the Soft Start in position.
2. Secure the screws that hold the mounting bracket to the compressor.



3. Connect the cable connectors to the Soft Start board.
4. Connect the Soft Start ground wire to the ground post on the compressor housing.

### Backplane Installation

1. Align the Backplane with the mounting holes, ensuring the cavity temperature sensor connector is available.
2. Insert and tighten fasteners at the top of the Backplane frame.
3. Insert and tighten frame ground screw at the bottom right of the Backplane. See Figure 3.
4. Connect all connectors to their appropriate locations. See Figure 8.
5. Remove the Inverter ground screw from top right of the Backplane. See Figure 8.
6. Connect Inverter cable ground ring to Inverter ground screw and install at top right of Backplane.

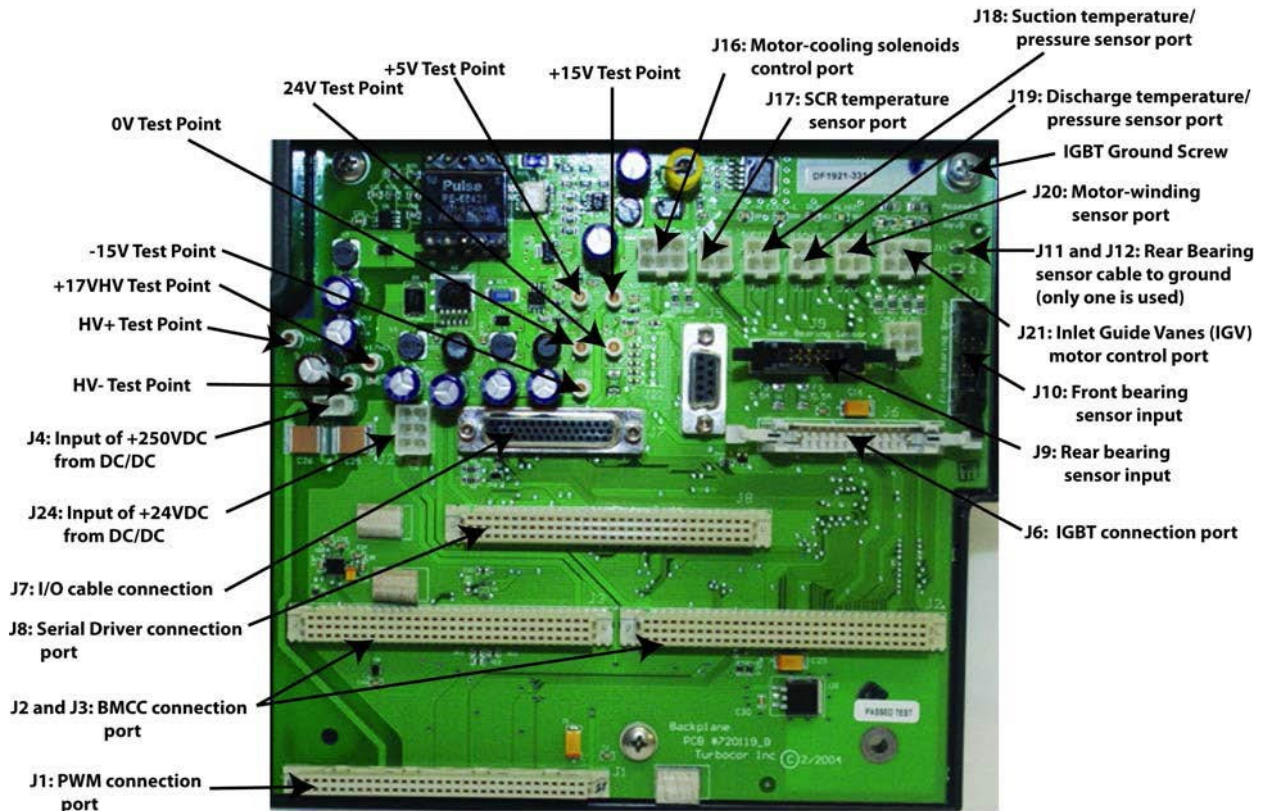

Figure 8 - Backplane Connections

### PWM Installation

1. Align the PWM's heat sink with the two (2) guide pins in the main compressor housing.
2. Insert the PWM into the J1 connector of the Backplane.
3. Secure the PWM's heat sink to the main compressor housing with three (3) screws.
4. Ensure the PWM's heat sink is firmly seated against the main compressor housing.
5. Place the two (2) cluster blocks on the front and rear radial bearing feedthroughs. See Figure 1.

### BMCC Installation

1. Align the BMCC's two (2) lower insertion guides so that they are on the inside of the bearing PWM Amplifier's two (2) upper insertion guides. See Figure 9.
2. Slide the BMCC straight into the connector until firmly seated in the Backplane connector J2 and J3. See Figure 8.

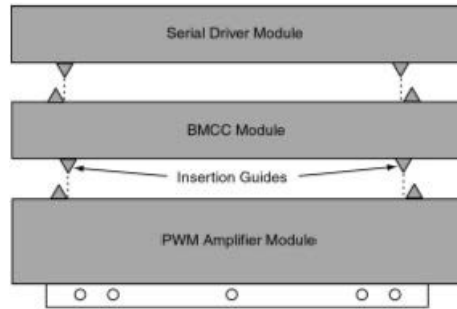

Figure 9 - BMCC Insertion Guides







### Serial Driver Installation

1. Carefully align the Serial Driver on top of the BMCC. See Figure 9.
2. Slide the Serial Driver onto the J8 connector on the Backplane. See Figure 8.

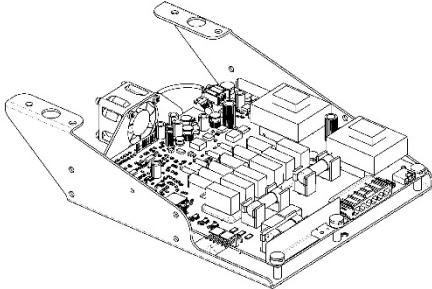
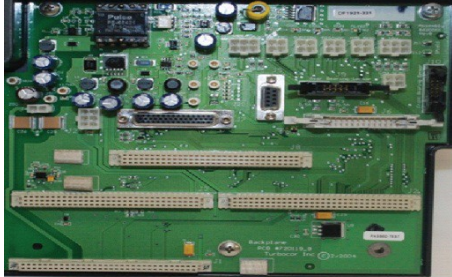

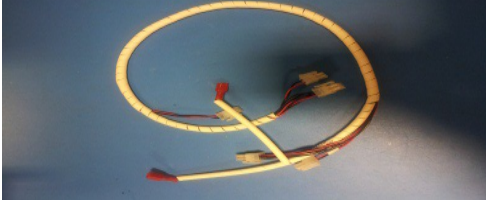
### I/O Board & Cable Installation

1. Install I/O board into the DIN rail.
2. Reconnect all external connections and wiring on the compressor I/O board.
3. Connect the male end of the I/O cable to the J7 connector on the Backplane.
4. Connect the female end of the I/O cable to the I/O board.
5. Inspect all connections.
6. Install topside, mains input, and service side covers.

5 - Kit Contents

QTY	Part(s) Description	Picture(s)
1	MODULE SOFT START	
1	MODULE BACKPLANE ASSEMBLY – MAIN ASSY.	
1	CABLE HARNESS COMPRESSOR CONTROLLER	
1	CABLE HARNESS COMPRESSOR DC SUPPLY Note: only for Kit 100515 and 100516.	
1	CABLE HARNESS ASSY CHILLER INTERFACE	
1	BEARING MOTOR COMPRESSOR CONTROLLER (BMCC) – MAIN ASSY.  <b>NOTE:</b> Ensure software that is compatible with the compressor is installed in the BMCC. Contact Product Support if further information is needed.	
1	MODULE SERIAL DRIVER MAIN ASSY.	

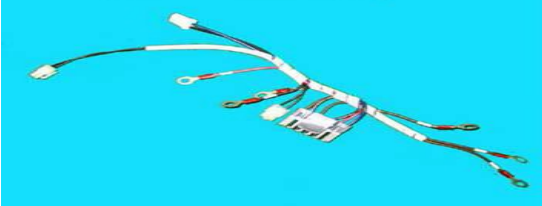

1	DC/DC CONVERTER ASSEMBLY	
1	KIT - PCB ASSEMBLY CHILLER INT. CONNECTOR	
1	CABLE HARNESS SOFTSTART SCR GATE	
1	CABLE HARNESS SOFTSTART AC/DC	

Danfoss can accept no responsibility for possible errors in catalogues, brochures and other printed material. Danfoss reserves the right to alter its products without notice. This also applies to products already on order provided that such alterations can be made without subsequential changes being necessary in specifications already agreed.

ENGINEERING  
TOMORROW



All trademarks in this material are property of the respective companies. Danfoss and the Danfoss logotype are trademarks of Danfoss A/S. All rights reserved.