

**DRIVE PARAMETERS**

PARAMETER #	NAME	SETTING	VALUE
0-03	REGIONAL SETTINGS	1	NORTH AMERICA
5-01	TERMINAL 27	1	OUTPUT
5-02	TERMINAL 29	2	OUTPUT
5-11	TERMINAL 19	52	RUN PERMISSIVE
5-14	TERMINAL 32	7	EXTERNAL INTERLOCK
5-15	TERMINAL 33	37	FIRE MODE
5-30	TERMINAL 27	188	FILTER CAP CONNECT
5-31	TERMINAL 29	5	RUNNING
5-40[0]	RELAY 1	160	NO ALARM
5-40[1]	RELAY 2	167	START COMMAND ACTIVE
14-51	DC LINK COMP.	0	OFF

**SOFTSTART PARAMETERS**

PARAMETER #	NAME	SETTING	VALUE
3-1	LOCAL/REMOTE	1	LCL/RMT ANYTIME
3-3	INPUT A FUNCTION	5	EMERGENCY RUN
3-8	REMOTE RESET	2	NORMALLY OPEN
15-5	MAIN CONTACTOR TIME	1500	START DELAY

- NOTES:**
- \* INDICATES COMPONENTS NOT SUPPLIED BY FACTORY.
  - FEEDER CIRCUIT PROTECTION AND INPUT AND MOTOR WIRING MUST BE SELECTED IN ACCORDANCE WITH THE N.E.C. ANY APPLICABLE LOCAL CODES AND THE DRIVE PANEL NAMEPLATE RATING. DANFOSS RECOMMENDS AN INSULATED BONDING WIRE FROM MOTOR TO DRIVE RUNNING WITH MOTOR LEADS INSIDE CONDUIT OR SHIELDED CABLE.
  - REPLACE JUMPER WITH N.C. SAFETY INTERLOCK CONTACT AS APPLICABLE.
  - REFER TO THE INSTALLATION OPERATION MANUAL FOR THE PROPER DRIVE FUSING. DRIVE FUSES ARE INTERNAL TO DRIVE ON UNITS > 125 HP.
  - ADD JUMPER TO ENABLE AUTO BYPASS FUNCTION.
  - JUMPER FROM H2 TO H3 IS NOT PRESENT ON TRANSFORMER PRIMARY FOR 575V INPUT..
  - REMOVE JUMPER TO ENABLE DAMPER FEEDBACK IN FIRE MODE.
  - ADD JUMPER TO FORCE BYPASS IN FIRE MODE.
  - MOTOR/LINE AND CONDUIT GROUND CONNECTIONS TO BE MADE ON CABINET GROUND BAR.

NOTE: ALL DRIVE WIRES #18 AWG BLUE UNLESS OTHERWISE NOTED  
 NOTE: ANALOG PAIRS ARE 18 AWG BELDEN #9460

3									
2									
1									
RELEASE	0	SP14067	11/05/14						
DESCRIPTION	REV	ECN	DATE						

- NOTICE -

THIS DOCUMENT CONTAINS PROPRIETARY INFORMATION OF DANFOSS DRIVES. IT IS LOANED BY DANFOSS DRIVES SUBJECT TO THE CONDITIONS THAT IT AND THE INFORMATION EMBODIED THEREIN SHALL BE USED ONLY FOR RECORD AND REFERENCE PURPOSES, SHALL NOT BE USED OR CAUSED TO BE USED IN ANY WAY PREJUDICIAL TO THE INTERESTS OF DANFOSS DRIVES, SHALL NOT BE REPRODUCED OR COPIED IN WHOLE OR IN PART, OR DISCLOSED TO ANYONE WITHOUT THE DIRECT WRITTEN PERMISSION OF DANFOSS DRIVES AND SHALL BE RETURNED UPON REQUEST.

DRN

SJG

APR

SJG

TOLERANCE

Unless Otherwise Specified

2 PLC. ±0.02

3 PLC. ±0.005

SCALE 1.0

NAME

POWER DISTRIBUTION WIRING DIAGRAM

PHD PANEL HVAC SOFT-START BYPASS 460/575 VAC

CB DISC., TYPE 1/12, WITH DV/DT FILTER

MODEL

FC102

SIZE

D

DWG. NO.

174H8968

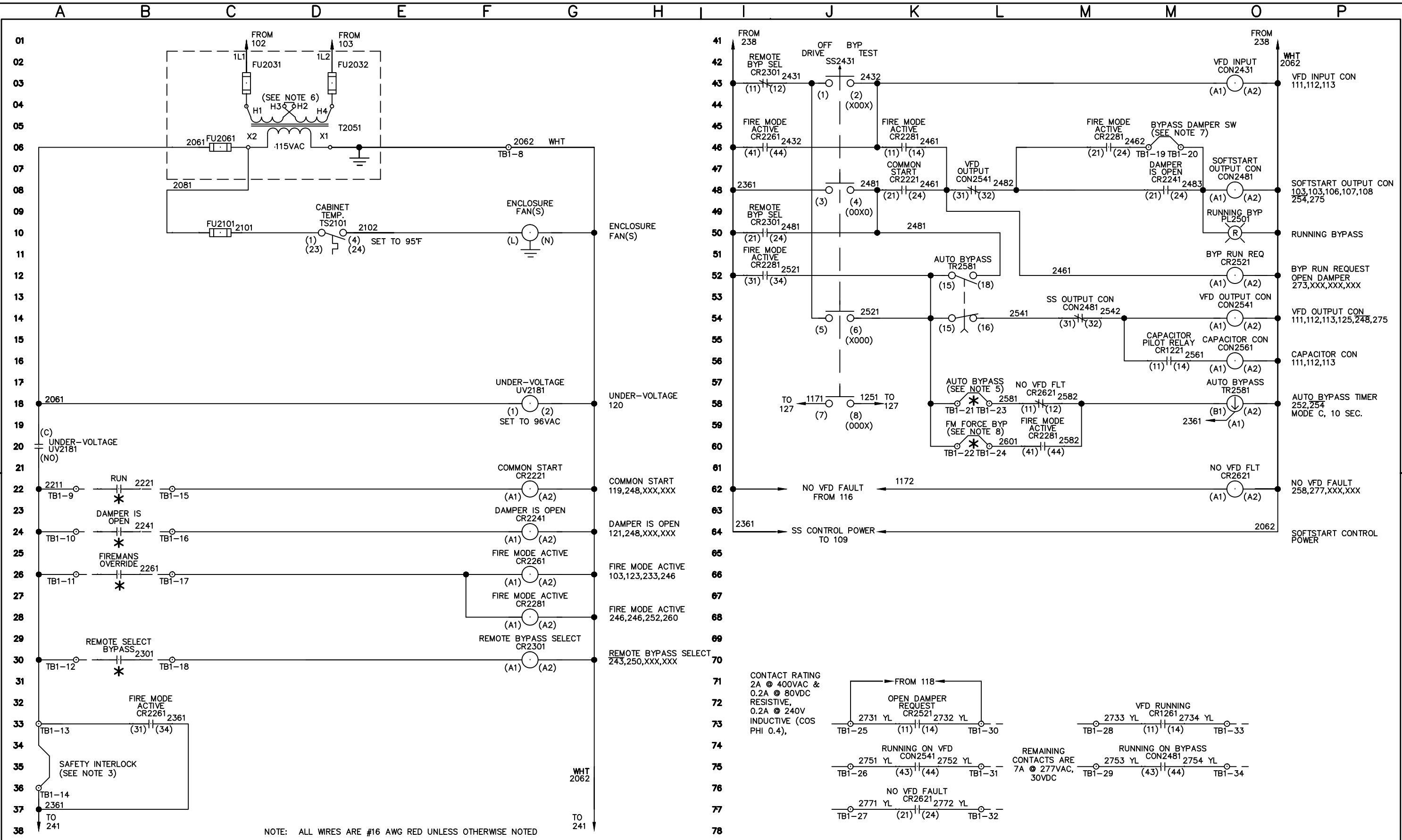

NOTE: ALL WIRES ARE #16 AWG RED UNLESS OTHERWISE NOTED

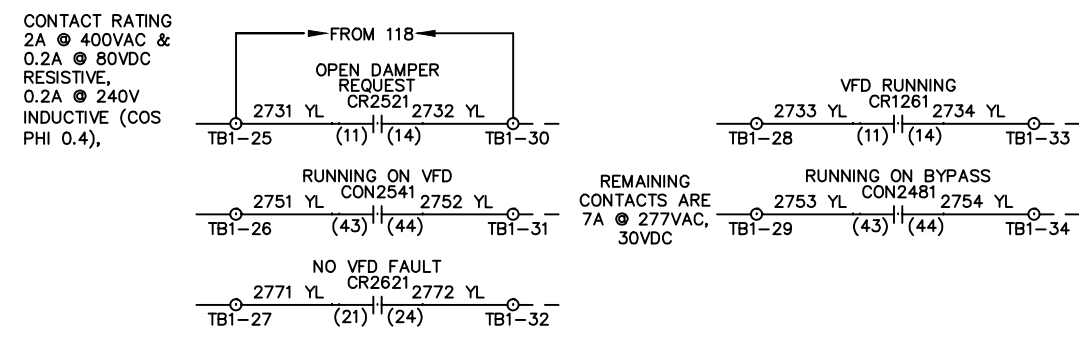

	3		
	2		
	1		
RELEASE	0	SP14067	11/05/14
DESCRIPTION	REV	ECN	DATE

- NOTICE -

THIS DOCUMENT CONTAINS PROPRIETARY INFORMATION OF DANFOSS DRIVES. IT IS LOANED BY DANFOSS DRIVES SUBJECT TO THE CONDITIONS THAT IT AND THE INFORMATION EMBODIED THEREIN SHALL BE USED ONLY FOR RECORD AND REFERENCE PURPOSES, SHALL NOT BE USED OR CAUSED TO BE USED IN ANY WAY PREJUDICIAL TO THE INTERESTS OF DANFOSS DRIVES, SHALL NOT BE REPRODUCED OR COPIED IN WHOLE OR IN PART, OR DISCLOSED TO ANYONE WITHOUT THE DIRECT WRITTEN PERMISSION OF DANFOSS DRIVES AND SHALL BE RETURNED UPON REQUEST.

DRN	SJG	TOLERANCE	NAME		CONTROL WIRING DIAGRAM	DWG. No.	174H8968
APR	SJG	Unless Otherwise Specified 2 PLC. ±.02 3 PLC. ±.005	MODEL	FC102			
SCALE 1.0			SHEET	2 OF 2	SIZE	D	

