

A B C D E F G H I J K L M M O P

NOTES:

1. ALLOW 12" MINIMUM CLEARANCE ON EXHAUST SIDE OF PANEL.
2. HATCHED AREA IS AVAILABLE FOR CONDUIT.

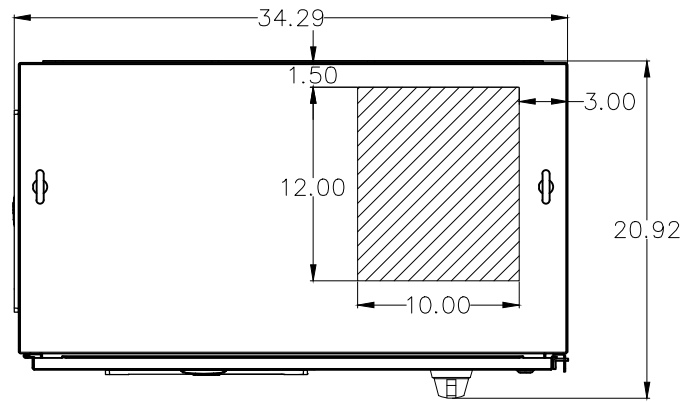

TOP VIEW

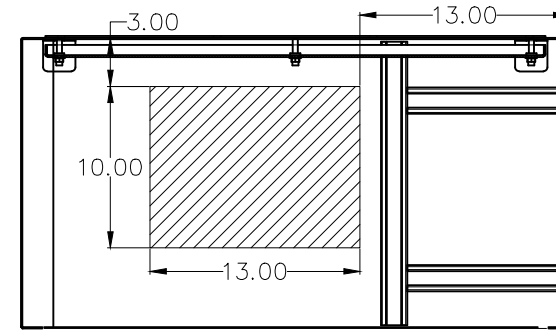

INSIDE VIEW OF FLOOR

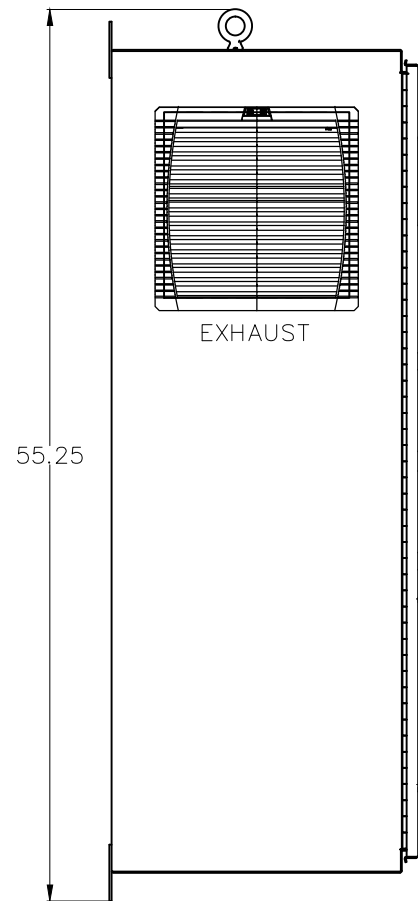

EXHAUST

55.25

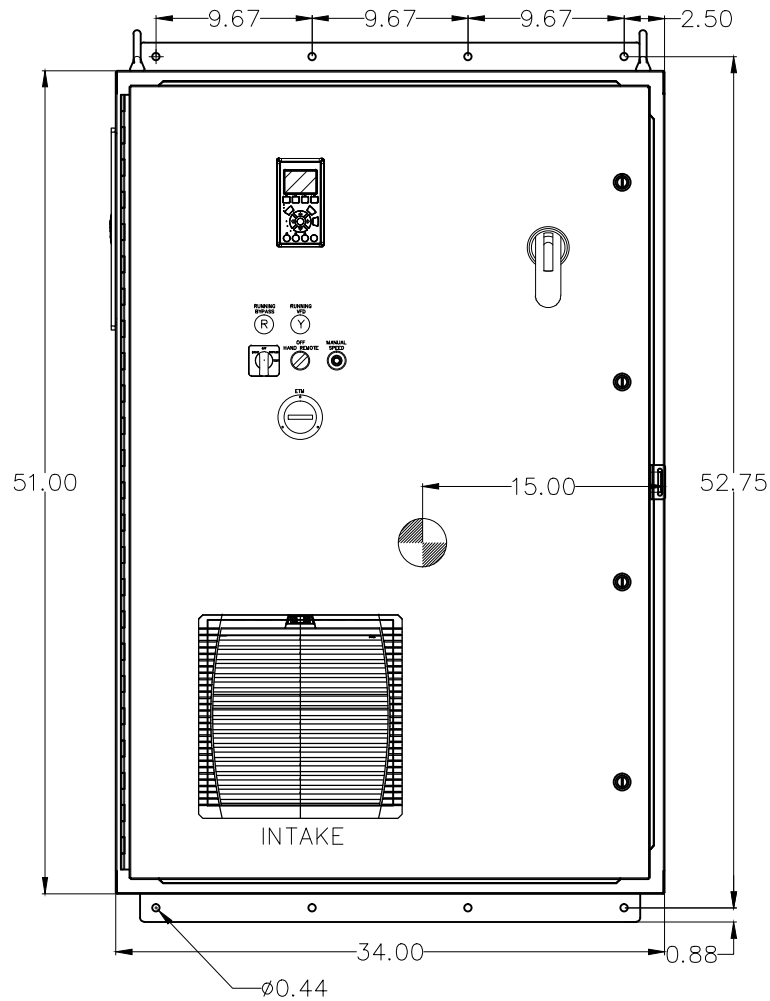

INTAKE

51.00

52.75

34.00

0.88

$\phi 0.44$

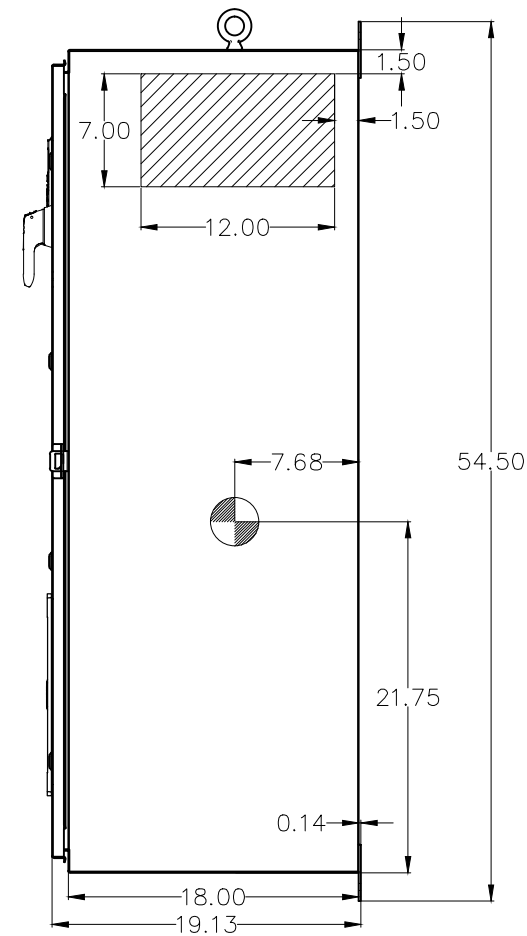

0.14

21.75

7.68

54.50

12.00

7.00

1.50

1.50

19.13

18.00

- NOTICE -  
THIS DOCUMENT CONTAINS PROPRIETARY INFORMATION OF DANFOSS DRIVES. IT IS LOANED BY DANFOSS DRIVES SUBJECT TO THE CONDITIONS THAT IT AND THE INFORMATION EMBODIED THEREIN SHALL BE USED ONLY FOR RECORD AND REFERENCE PURPOSES, SHALL NOT BE USED OR CAUSED TO BE USED IN ANY WAY PREJUDICIAL TO THE INTERESTS OF DANFOSS DRIVES, SHALL NOT BE REPRODUCED OR COPIED IN WHOLE OR IN PART, OR DISCLOSED TO ANYONE WITHOUT THE DIRECT WRITTEN PERMISSION OF DANFOSS DRIVES AND SHALL BE RETURNED UPON REQUEST.

DRN  
JHJ  
APR  
SJG

TOLERANCE  
Unless  
Otherwise  
Specified  
2 PLC.  $\pm 0.02$   
3 PLC.  $\pm 0.005$   
SCALE 1.0

NAME AQUA PHD PANEL, 3 CONTACTOR BYPASS, 1.5 - 75 HP, OR SOFTSTART BYPASS, 1.5 - 25HP, 480 / 600 VAC, NEMA 1, 12, DIMENSIONAL DWG.  
MODEL FC-202

**Danfoss**  
Milwaukee, WI.  
SIZE D  
DWG. NO. 174N9315-04

7			3		
6			2		
5			1		
4			0		03/12/14
REV	ECN	DATE	REV	ECN	DATE

SHEET 1 OF 1