

DRIVE PARAMETERS

PARAMETER #	NAME	SETTING	VALUE
0-03	REGIONAL SETTINGS	1	NORTH AMERICA
0-10	ACTIVE SETUP	9	MULTI SETUP
3-15	REFERENCE 1 SOURCE	1	SETUP 1
5-01	TERMINAL 27	1	OUTPUT
5-02	TERMINAL 29	2	OUTPUT
5-11	TERMINAL 19	23	SETUP SELECT
5-14	TERMINAL 32	7	EXTERNAL INTERLOCK
5-30	TERMINAL 27	188	FILTER CAP CONNECT
5-31	TERMINAL 29	5	RUNNING
5-40(0)	RELAY 1	160	NO ALARM

SOFTSTART PARAMETERS

PARAMETER #	NAME	SETTING	VALUE
3-1	LOCAL/REMOTE	N/A	LCL/RMT ANYTIME
15-5	MAIN CONTACTOR TIME	1500	START DELAY

- NOTES:
- *INDICATES COMPONENTS NOT SUPPLIED BY FACTORY.
 - FEEDER CIRCUIT PROTECTION AND INPUT AND MOTOR WIRING MUST BE SELECTED IN ACCORDANCE WITH THE N.E.C., ANY APPLICABLE LOCAL CODES AND THE DRIVE CURRENT RATING. DANFOSS RECOMMENDS AN INSULATED BONDING WIRE FROM MOTOR TO DRIVE RUNNING WITH MOTOR LEADS INSIDE CONDUIT OR SHIELDED CABLE.
 - REPLACE JUMPER WITH N.C. SAFETY INTERLOCK CONTACT AS APPLICABLE.
 - REFER TO THE INSTALLATION, OPERATION MANUAL FOR THE PROPER DRIVE FUSING. DRIVE FUSES ARE INTERNAL TO DRIVE ON UNITS > 150 HP.
 - FOR 575V INPUT POWER JUMPER FROM H2 TO H3 IS NOT PRESENT.
 - MOTOR/LINE AND CONDUIT GROUND CONNECTIONS TO BE MADE ON CABINET GROUND BAR.

NOTE: ALL WIRES #16 AWG BLUE UNLESS OTHERWISE NOTED
 NOTE: ANALOG PAIRS ARE 18 AWG BELDEN #9460

				- NOTICE -		DRN		TOLERANCE		NAME			
				THIS DOCUMENT CONTAINS PROPRIETARY INFORMATION OF DANFOSS DRIVES. IT IS LOANED BY DANFOSS DRIVES SUBJECT TO THE CONDITIONS THAT IT AND THE INFORMATION EMBODIED THEREIN SHALL BE USED ONLY FOR RECORD AND REFERENCE PURPOSES, SHALL NOT BE USED OR CAUSED TO BE USED IN ANY WAY PREJUDICIAL TO THE INTERESTS OF DANFOSS DRIVES, SHALL NOT BE REPRODUCED OR COPIED IN WHOLE OR IN PART, OR DISCLOSED TO ANYONE WITHOUT THE DIRECT WRITTEN PERMISSION OF DANFOSS DRIVES AND SHALL BE RETURNED UPON REQUEST.		SJK		Unless Otherwise Specified		POWER DISTRIBUTION WIRING DIAGRAM PHD PANEL AQUA SOFT-START BYPASS 460/575 VAC FUSED DISCONNECT, TYPE 3R, WITH DV/DT FILTER			
						APR		2 PLC. ±.02 3 PLC. ±.005		MODEL		DWG. NO.	
DESCRIPTION				REV		SJK		SCALE 1.0		FC202		174N9992	
				6/12/14						SHEET 1 OF 2		SIZE D	

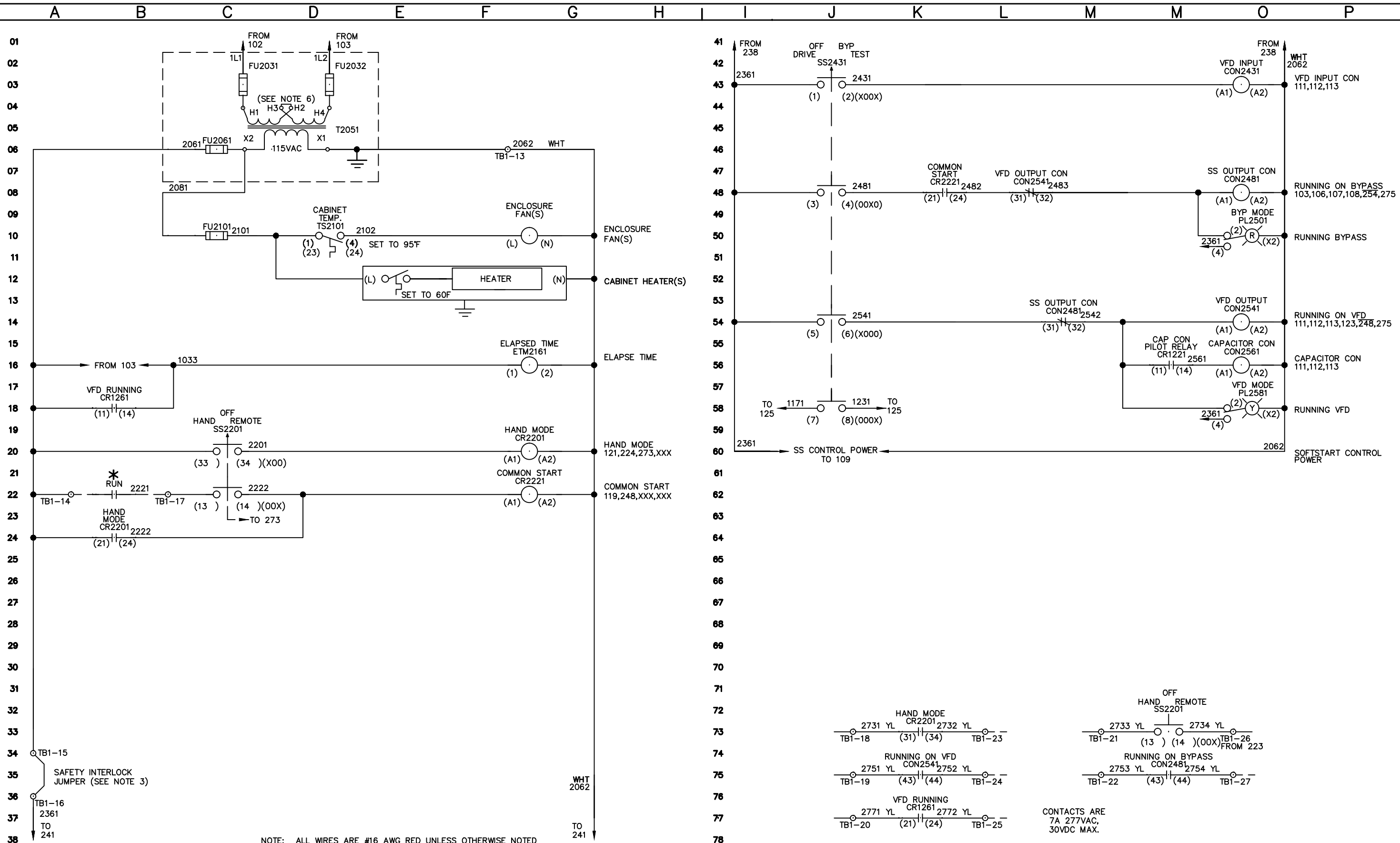

NOTE: ALL WIRES ARE #16 AWG RED UNLESS OTHERWISE NOTED

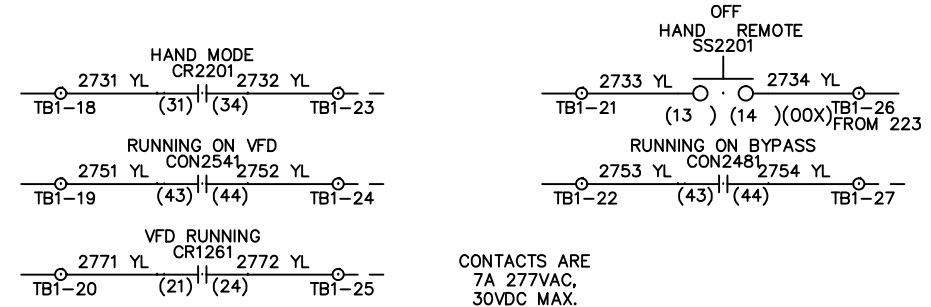

	C		
	B		
	A		
	DR		6/12/14
DESCRIPTION	REV	ECN	DATE

- NOTICE -
 THIS DOCUMENT CONTAINS PROPRIETARY INFORMATION OF DANFOSS DRIVES. IT IS LOANED BY DANFOSS DRIVES SUBJECT TO THE CONDITIONS THAT IT AND THE INFORMATION EMBODIED THEREIN SHALL BE USED ONLY FOR RECORD AND REFERENCE PURPOSES, SHALL NOT BE USED OR CAUSED TO BE USED IN ANY WAY PREJUDICIAL TO THE INTERESTS OF DANFOSS DRIVES, SHALL NOT BE REPRODUCED OR COPIED IN WHOLE OR IN PART, OR DISCLOSED TO ANYONE WITHOUT THE DIRECT WRITTEN PERMISSION OF DANFOSS DRIVES AND SHALL BE RETURNED UPON REQUEST.

DRN	SJG	TOLERANCE	NAME		CONTROL WIRING DIAGRAM	
	SJG	Unless Otherwise Specified	PHD PANEL AQUA SOFT START BYPASS 460/575 VAC			
APR	SJG	2 PLC. ±.02 3 PLC. ±.005	MODEL	FC202	SHEET 2 OF 2	SIZE D
		SCALE 1.0			DWG. NO.	174N9992

