

WIRE COLOR SCHEME
 BLACK - LINE VOLTAGE
 RED - AC CONTROL
 WHITE - AC GROUNDED
 CIRCUIT CONDUCTOR
 BLUE - DC CONTROL
 WHT/BLU - DC CONTROL COMMON
 GREEN - CHASSIS GROUND

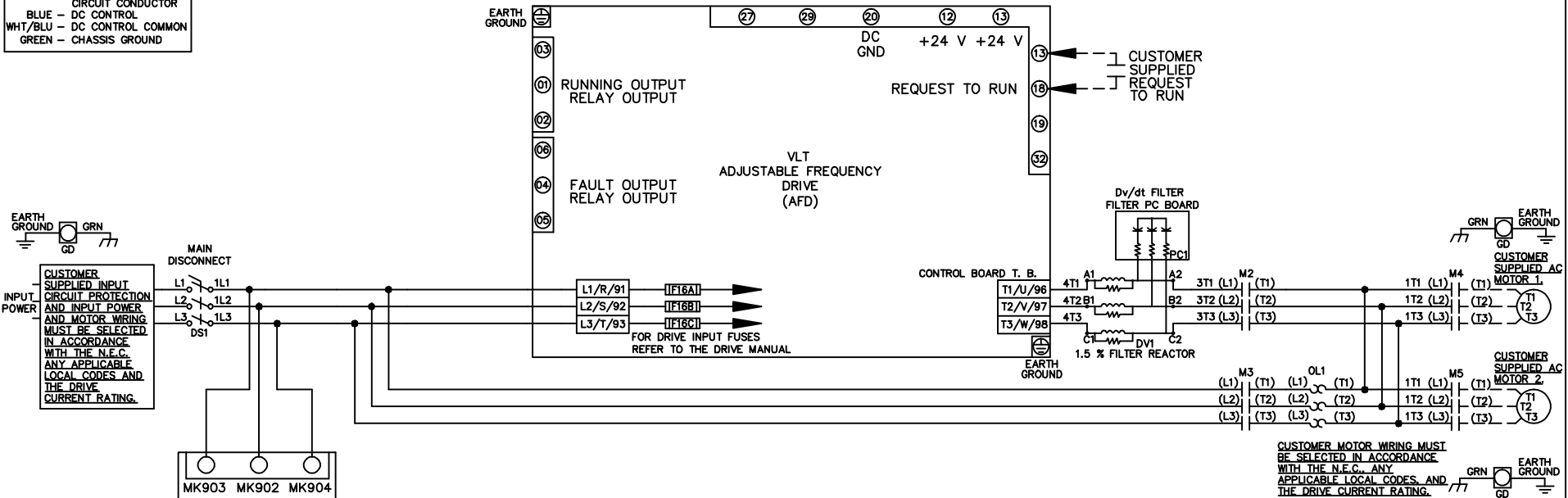

INPUT POWER
 CUSTOMER SUPPLIED INPUT CIRCUIT PROTECTION AND INPUT POWER AND MOTOR WIRING MUST BE SELECTED IN ACCORDANCE WITH THE N.E.C. ANY APPLICABLE LOCAL CODES AND THE DRIVE CURRENT RATING.

CUSTOMER MOTOR WIRING MUST BE SELECTED IN ACCORDANCE WITH THE N.E.C. ANY APPLICABLE LOCAL CODES AND THE DRIVE CURRENT RATING.

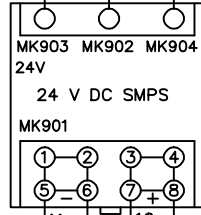

CONNECTS TO TB2 TERMINAL BLOCK

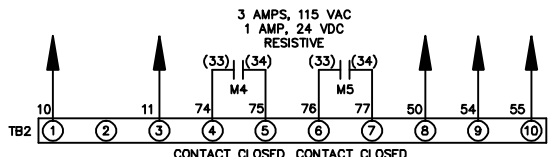

CONTACT CLOSED CONTACT CLOSED INDICATES INDICATES
 MTR 1 SELECTED MTR 2 SELECTED
 STATUS CONTACTS FOR CUSTOMER USE

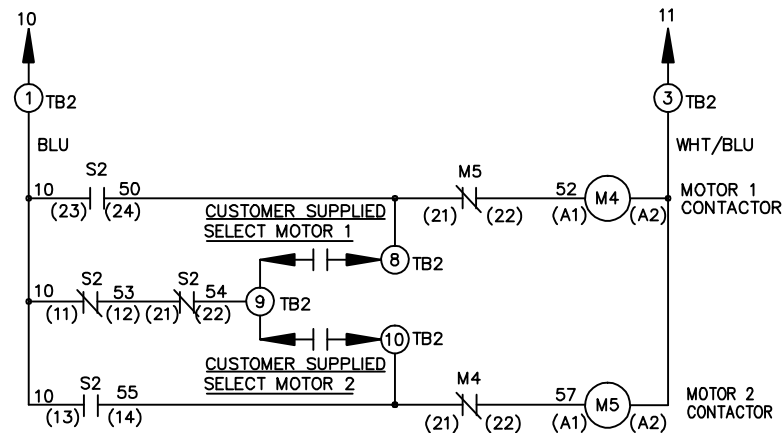

CONTACT SEQUENCE CHART FOR S2
 X INDICATES CONTACT CLOSED

| CONTACT | MOTOR 1 | AUTO | MOTOR 2 |
|---------|---------|------|---------|
| 11-12 | X | X | |
| 13-14 | | | X |
| 21-22 | | X | X |
| 23-24 | X | | |

- NOTICE -

THIS DOCUMENT CONTAINS PROPRIETARY INFORMATION OF DANFOSS DRIVES. IT IS LOANED BY DANFOSS DRIVES SUBJECT TO THE CONDITIONS THAT IT AND THE INFORMATION EMBODIED THEREIN SHALL BE USED ONLY FOR RECORD AND REFERENCE PURPOSES, SHALL NOT BE USED OR CAUSED TO BE USED IN ANY WAY PREJUDICIAL TO THE INTERESTS OF DANFOSS DRIVES, SHALL NOT BE REPRODUCED OR COPIED IN WHOLE OR IN PART, OR DISCLOSED TO ANYONE WITHOUT THE DIRECT WRITTEN PERMISSION OF DANFOSS DRIVES AND SHALL BE RETURNED UPON REQUEST.

DRN JNW
 2/14/07

NAME 208-600VOLT, 2C, MAIN DISC
 ,DRIVE FUSE, ECB, FRAME A5-B1
 ,DVDT, CMS



A SP08061 10/08
 REV ECN DATE

APR

MODEL

PAGE 1 OF 2

SIZE A

DWG NO.

174U0411

| | | | | | |
|-----|---|-----|---------|------|-------|
| REV | A | ECN | SP08066 | DATE | 10/08 |
|-----|---|-----|---------|------|-------|

THIS DOCUMENT CONTAINS PROPRIETARY INFORMATION OF DANFOSS DRIVES. IT IS LOANED BY DANFOSS DRIVES SUBJECT TO THE CONDITIONS THAT IT AND THE INFORMATION EMBODIED THEREIN SHALL BE USED ONLY FOR RECORD AND REFERENCE PURPOSES. SHALL NOT BE USED OR CAUSED TO BE USED IN ANY WAY PREJUDICIAL TO THE INTERESTS OF DANFOSS DRIVES. SHALL NOT BE REPRODUCED OR COPIED IN WHOLE OR IN PART, OR DISCLOSED TO ANYONE WITHOUT THE DIRECT WRITTEN PERMISSION OF DANFOSS DRIVES AND SHALL BE RETURNED UPON REQUEST.

DRN JNW
2/14/07
APR

NAME 208-600VOLT,2C,MAIN DISC
,DRIVE FUSE,ECB,FRAME A5-B1
,DVDT,CMS

MODEL
PAGE 2 OF 2
SIZE A
DWG NO. 174U0411

CUSTOMER CONNECTIONS X56,X57,X59
CLASS 2 POWER SOURCE
REQUIRED FOR FIELD CONNECTION
USE CLASS 1 CONDUCTORS
CONDUCTOR SIZE 28-14 AWG

