

**WIRE COLOR SCHEME**  
 BLACK - LINE VOLTAGE  
 RED - AC CONTROL  
 WHITE - AC GROUND  
 WHITE - CIRCUIT CONDUCTOR  
 BLUE - DC CONTROL  
 WHT/BLU - DC CONTROL COMMON  
 GREEN - CHASSIS GROUND

\* ALL CONTROL WIRES ARE BLUE EXCEPT WHERE NOTED. TO ELECTROMECHANICAL RELAY BOARD

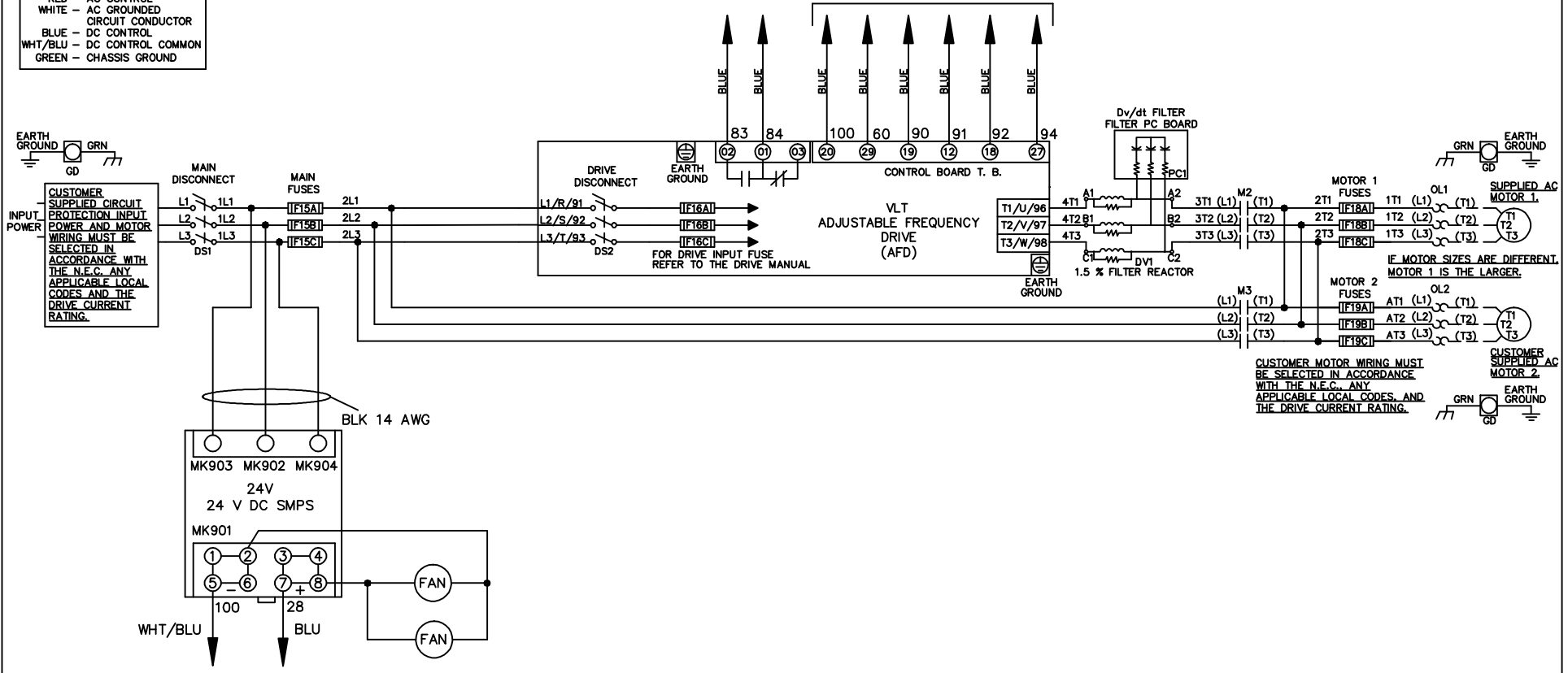

			- NOTICE -		DRN JNW 2/14/07		NAME 208-600VOLT, 2C, MAIN&DRIVE DISC , MAIN FUSE, EMB2, FRAME C1N12 , DVDT, DUAL MTR		<i>Danfoss</i>	
A	SP08061	10/08	THIS DOCUMENT CONTAINS PROPRIETARY INFORMATION OF DANFOSS DRIVES. IT IS LOANED BY DANFOSS DRIVES SUBJECT TO THE CONDITIONS THAT IT AND THE INFORMATION EMBODIED THEREIN SHALL BE USED ONLY FOR RECORD AND REFERENCE PURPOSES, SHALL NOT BE USED OR CAUSED TO BE USED IN ANY WAY PREJUDICIAL TO THE INTERESTS OF DANFOSS DRIVES, SHALL NOT BE REPRODUCED OR COPIED IN WHOLE OR IN PART, OR DISCLOSED TO ANYONE WITHOUT THE DIRECT WRITTEN PERMISSION OF DANFOSS DRIVES AND SHALL BE RETURNED UPON REQUEST.			APR	MODEL	PAGE 1 OF 2	SIZE A	DWG NO. 174U0910
REV	ECN	DATE								

REV	ECN	DATE
A	SP08066	10/08

CONTACT SEQUENCE CHART FOR S1	
POSITION	CONTACT
DRIVE	13-14
OFF	23-24
BYPASS	X

THIS DOCUMENT CONTAINS PROPRIETARY INFORMATION OF DANFOSS DRIVES. IT IS LOANED BY DANFOSS DRIVES SUBJECT TO THE CONDITIONS THAT IT AND THE INFORMATION EMBODIED THEREIN SHALL BE USED ONLY FOR RECORD AND REFERENCE PURPOSES. SHALL NOT BE USED OR CAUSED TO BE USED IN ANY WAY PREJUDICIAL TO THE INTERESTS OF DANFOSS DRIVES. SHALL NOT BE REPRODUCED OR COPIED IN WHOLE OR IN PART, OR DISCLOSED TO ANYONE WITHOUT THE DIRECT WRITTEN PERMISSION OF DANFOSS DRIVES AND SHALL BE RETURNED UPON REQUEST.

DRN JUNW  
2/14/07

NAME 208-600VOLT, 2C, MAIN&DRIVE DISC  
, MAIN FUSE, EMB2, FRAME C1N12  
, DVD1, DUAL MTR

PAGE 2 OF 2  
SIZE A  
DWG NO. 174U0910

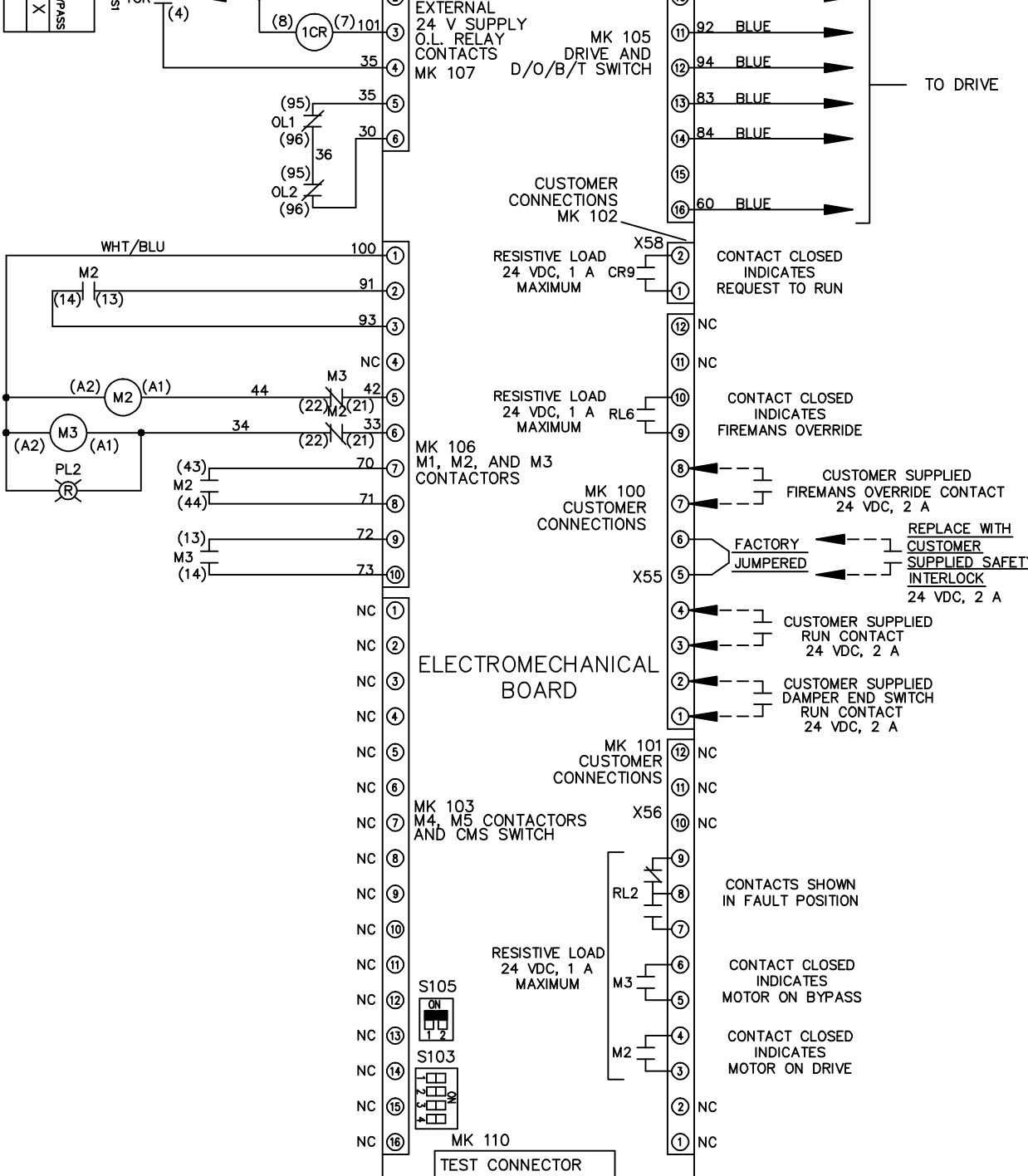

CUSTOMER CONNECTIONS X55, X56, X58  
CLASS 2 POWER SOURCE  
REQUIRED FOR FIELD CONNECTION  
USE CLASS 1 CONDUCTORS  
CONDUCTOR SIZE 28-14 AWG

