

WIRE COLOR SCHEME
 BLACK - LINE VOLTAGE
 RED - AC CONTROL
 WHITE - AC GROUNDED
 CIRCUIT CONDUCTOR
 BLUE - DC CONTROL
 WHT/BLU - DC CONTROL COMMON
 GREEN - CHASSIS GROUND

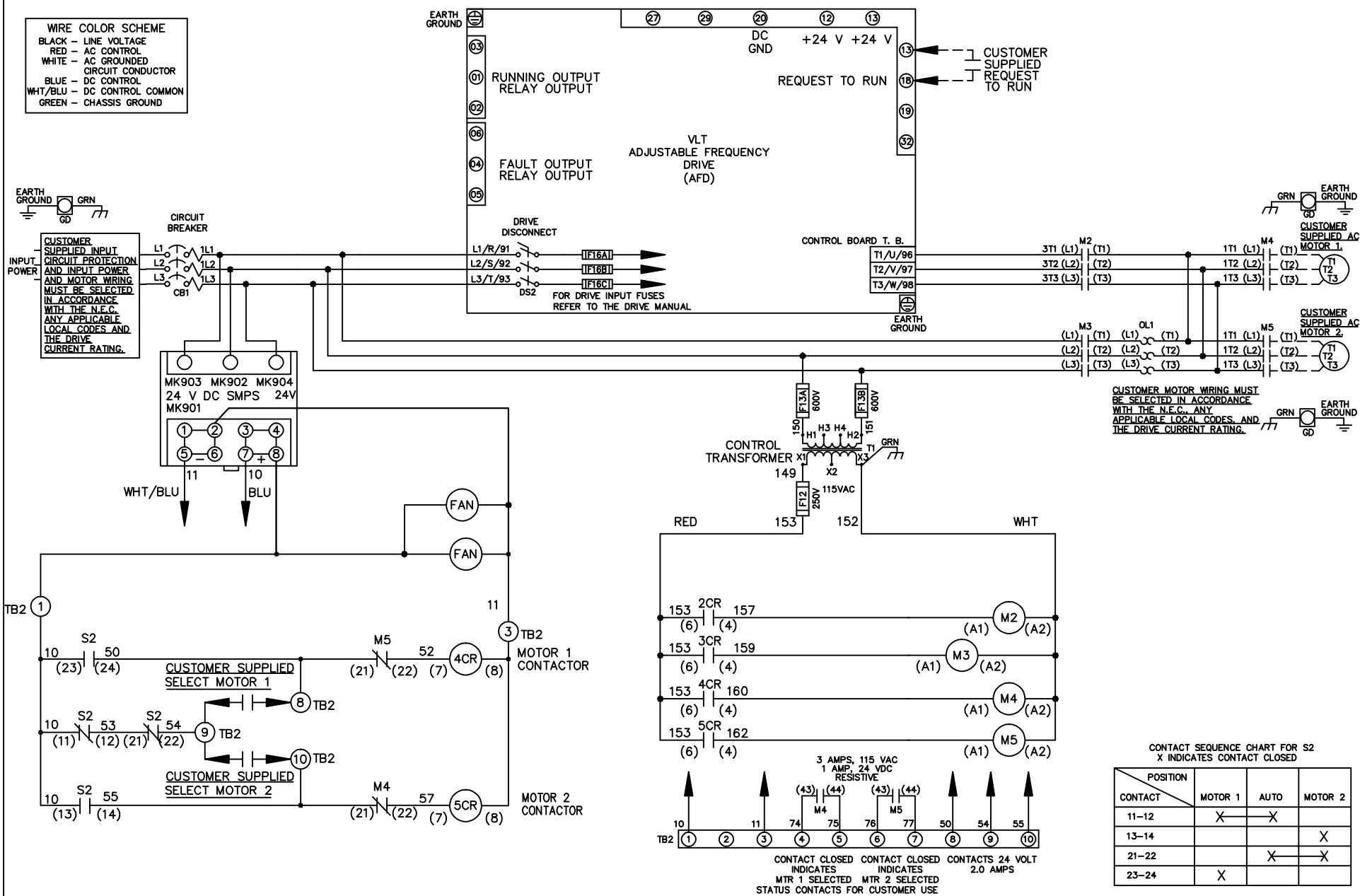

CUSTOMER MOTOR WIRING MUST BE SELECTED IN ACCORDANCE WITH THE N.E.C. ANY APPLICABLE LOCAL CODES, AND THE DRIVE CURRENT RATING.

CONTACT SEQUENCE CHART FOR S2
 X INDICATES CONTACT CLOSED

POSITION	MOTOR 1	AUTO	MOTOR 2
11-12	X	X	
13-14			X
21-22		X	X
23-24	X		

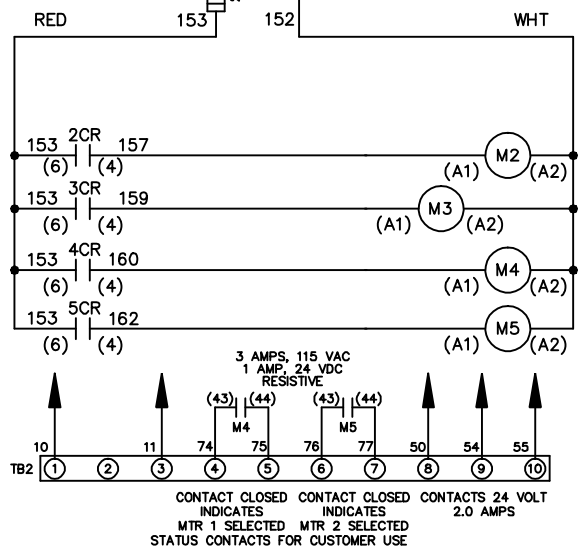

<p align="center">- NOTICE -</p> <p>THIS DOCUMENT CONTAINS PROPRIETARY INFORMATION OF DANFOSS DRIVES. IT IS LOANED BY DANFOSS DRIVES SUBJECT TO THE CONDITIONS THAT IT AND THE INFORMATION EMBODIED THEREIN SHALL BE USED ONLY FOR RECORD AND REFERENCE PURPOSES. SHALL NOT BE USED OR CAUSED TO BE USED IN ANY WAY PREJUDICIAL TO THE INTERESTS OF DANFOSS DRIVES, SHALL NOT BE REPRODUCED OR COPIED IN WHOLE OR IN PART, OR DISCLOSED TO ANYONE WITHOUT THE DIRECT WRITTEN PERMISSION OF DANFOSS DRIVES AND SHALL BE RETURNED UPON REQUEST.</p>			DRN JNW 2/14/07 APR	NAME 208 VOLT,2C,CB & DRIVE DISC ,DRIVE FUSE,ECB,FRAME C2N12 ,NO REACTOR & DVDT,CMS	
REV A ECN SP08061 DATE 10/08	MODEL PAGE 1 OF 2 SIZE A DWG NO. 174U1880				

REV	ECN	DATE
A	SP08066	10/08

NOTICE -
 THIS DOCUMENT CONTAINS PROPRIETARY INFORMATION OF DANFOSS DRIVES. IT IS LOANED BY DANFOSS DRIVES SUBJECT TO THE CONDITIONS THAT IT AND THE INFORMATION EMBODIED HEREIN SHALL BE USED ONLY FOR RECORD AND REFERENCE PURPOSES. SHALL NOT BE USED OR COPIED OR BE USED IN ANY MANNER, IN WHOLE OR IN PART, OR DISCLOSED TO ANYONE WITHOUT THE DIRECT WRITTEN PERMISSION OF DANFOSS DRIVES AND SHALL BE RETURNED UPON REQUEST.

DRN JNW
 2/14/07
 APR

NAME 208 VOLT, 2C, CB & DRIVE DISC
 , DRIVE FUSE, ECB, FRAME C2N12
 , NO REACTOR & DVDI, CMS

MODEL
 PAGE 2 OF 2
 SIZE A
 DWG NO. 174U1880



CUSTOMER CONNECTIONS X56, X57, X59
 CLASS 2 POWER SOURCE
 REQUIRED FOR FIELD CONNECTION
 USE CLASS 1 CONDUCTORS
 CONDUCTOR SIZE 28-14 AWG



ECB BOARD TB1

① EXTERNAL 24 V SUPPLY
 ②

CUSTOMER MOTOR RUNNING CONTACT
 ① 0-24 VDC MAXIMUM 1 AMPS DC RESISTIVE
 ②

NC ③
 NC ④ + 24 V
 NC ⑤
 NC ⑥
 NC ⑦ + 24 V
 NC ⑧
 NC ⑨
 NC ⑩ + 24 V
 NC ⑪
 NC ⑫

① SAFETY INTERLOCK
 ② COM

③ CMS MOTOR SELECTED
 ④
 ⑤ O.L. TRIP
 ⑥ M2 STATUS
 ⑦ M3 STATUS
 ⑧ BYPASS MODE ENABLE
 ⑨ BYPASS OVERRIDE
 ⑩ O.L. RESET

① COM
 ② COM

NC ③
 NC ④
 ⑤ DRIVE MODE
 ⑥ BYPASS MODE
 ⑦ COM
 ⑧ COM

TEST CONNECTOR MK 110